



**Ontario's Water Conference and Trade Show**  
May 8 - 10, 2017  
Scotiabank Convention Centre

**GES** is pleased to have been selected the official service partner by the Show Organizer to design and produce your show. Our goal is to ensure your show participation is a success.

**GES** is involved in many areas relative to the show and if at any time during the planning process you are unsure where to turn, just ask us, we are at your service.

Please ensure that you review this section carefully as it contains information on **Advance Pricing dates** that will save you money and order forms for our products and services.

For your convenience, we will be offering the following services:

- ✓ **Online Ordering thru Expresso**
- ✓ **Furnishings**
- ✓ **Carpet & Underpadding**
- ✓ **Specialty Furnishings**
- ✓ **Exhibits & Accessories**
- ✓ **Signs & Graphics**
- ✓ **Plants**
- ✓ **Installation & Dismantling Labour**
- ✓ **Material Handling**
- ✓ **GES Logistics / Shipping**
- ✓ **GES Customs**

Take advantage of up to 30% discount off our Regular Price, by ordering on or before the Advance Date of **April 17, 2017** as indicated on each form.

**GES** accepts Visa, MasterCard, American Express, Cheques and Cash as methods of payment for our services. All exhibitors are responsible for payment of H.S.T. when exhibiting in Ontario.

If you need assistance or additional information, please contact our **Exhibitor Services Department at (905) 283-0500.**  
**[torontoexhibitorservices@ges.com](mailto:torontoexhibitorservices@ges.com)**

Venue	Venue Shipping Address
Scotiabank Convention Centre 6815 Stanley Ave. Niagara Falls ON. L2G 3Y9	Scotiabank Convention Centre 6815 Stanley Ave. Niagara Falls ON. L2G 3Y9

Official Services Contractor		
Global Experience Specialists, Inc. (GES) 5675 McLaughlin Road Mississauga, Ontario, Canada L5R 3K5	Phone Fax Web Site E-Mail	905-283-0500 905-283-0501 www.gesexpo.ca torontoexhibitorservices@ges.com

Show Information	
Booth Size	10' x 10'
Backwall Drape	Blue/white/white/blue
Sidewall Drape	Blue
Aisle Carpet Colour	9' Blue
Booth Packages Includes:	1 - draped booth 1 - 6' or 8' blue skirted table. 1 grey fabric side chair 1 - 10' x 10' blue carpet 1 - wastebasket.

Important Dates - Prior to Show	
Advance Deadline for GES orders received with payment	Mon. Apr. 17th. 2017
Direct Shipments may arrive at Exhibit Site	Mon. May 8th. 2017
Last day for Direct Shipments to arrive at Exhibit Site	Mon. May 8th. 2017

Important Dates - At the Show	
Move In	Mon. May 8th. 11am - 5 pm.
Show Hours	Mon. May 8th. 7pm. - 10pm. Tues. May 9th. 7am. - 4pm. Wed. May 10th. 7:30 am. 12:30 pm.
Move Out	Wed. May 10th. 12:30 pm. - 5 pm.

**GES On-Site Service Centre**  
 GES will operate a GES Service Desk to help take care of your on-site requirements such as Furniture and Carpet  
 The Service Desk will be open during the following times:  
 N/A



## Accelerate your experience using the Expresso planning, ordering and management tool.

With just a few clicks, exhibitors can order GES products and services through Expresso including:

- Booth furnishings
- Carpet and Flooring
- Material handling
- Booth labour
- Signs and Graphics (custom)
- And much more

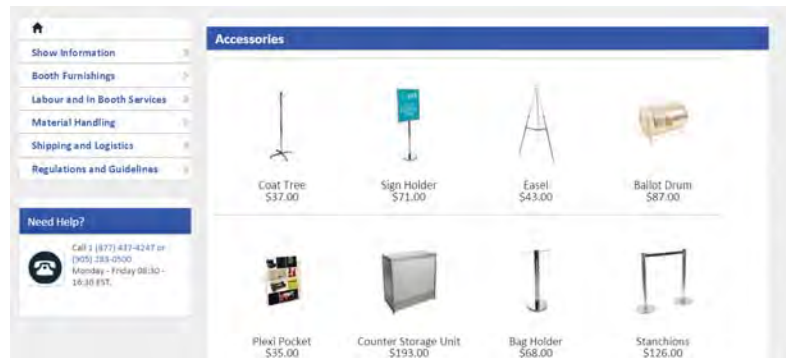

### Experience a difference with Expresso.

- Each show has their own custom website
- Print shipping labels
- Download the show schedule and forms
- View order history
- View important show and event information
- Keeps you on-time and on-budget

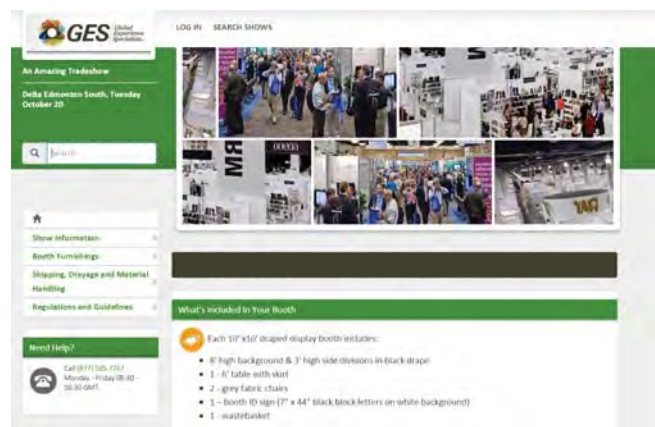



**CREDIT CARD AUTHORIZATION**

5675 McLaughlin Road, Mississauga, Ontario, L5R 3K5 Tel: 905-283-0500 Fax: 905-283-0501 Toll Free: 1-877-437-4247  
torontoexhibitorservices@ges.com www.gesexpo.ca

SHOW: **Ontario's Water Conference and Trade Show**

**EXHIBITOR INFORMATION**

**BOOTH #:** \_\_\_\_\_

COMPANY \_\_\_\_\_

STREET \_\_\_\_\_

CITY \_\_\_\_\_ PROV/STATE \_\_\_\_\_ CODE \_\_\_\_\_

E-MAIL \_\_\_\_\_

PHONE \_\_\_\_\_ FAX \_\_\_\_\_

CONTACT NAME \_\_\_\_\_

**IMPORTANT - READ CAREFULLY**

**Please fill out The Credit Card Authorization below if:**

- You or your company are forwarding payment to GES in the form of a cheque.
- There is any possibility you or your representative will be ordering any service on-site.
- You are ordering Material Handling, Installation and Dismantle Labour or In-Booth Forklift Services.

**PLEASE COMPLETE THE FOLLOWING**

MASTERCARD     VISA     AMERICAN EXPRESS    EXPIRY DATE:

CORPORATE     PERSONAL

**CARD #**

CARDHOLDER'S NAME (PRINT): \_\_\_\_\_

CARDHOLDER'S SIGNATURE: \_\_\_\_\_

Cardholder's Billing Address: \_\_\_\_\_

City: \_\_\_\_\_ Prov/State: \_\_\_\_\_ Code/Zip: \_\_\_\_\_

Tel: \_\_\_\_\_ Fax: \_\_\_\_\_

This authorization allows GES to charge any fees outstanding after show closing to this credit card (including funds owed due to a cheque returned NSF)

**CHEQUES WILL NOT BE ACCEPTED WITHOUT THIS CREDIT CARD AUTHORIZATION**

**IF THIS AUTHORIZATION IS NOT COMPLETED, ALL ON-SITE ORDERS ARE EXPECTED TO BE PAID IN FULL BEFORE DELIVERY**



# THIRD PARTY BILLING

5675 McLaughlin Road, Mississauga, Ontario, L5R 3K5 Tel: 905-283-0500 Fax: 905-283-0501 Toll Free: 1-877-437-4247  
torontoexhibitorservices@ges.com www.gesexpo.ca

SHOW: **Ontario's Water Conference and Trade Show**

## EXHIBITOR INFORMATION

BOOTH #: \_\_\_\_\_

COMPANY \_\_\_\_\_

STREET \_\_\_\_\_

CITY \_\_\_\_\_ PROV/STATE \_\_\_\_\_ CODE \_\_\_\_\_

E-MAIL \_\_\_\_\_

PHONE \_\_\_\_\_ FAX \_\_\_\_\_

CONTACT NAME \_\_\_\_\_

You may arrange for an exhibit house or other agent to handle your display & be charged for services. GES will agree to this arrangement if the exhibit house or agent makes satisfactory payment arrangements with us. Both firms must complete this form and return to GES by the Advance Price Deadline Date. It is understood and agreed that the exhibitor is ultimately responsible for payment of charges. If your named third party has not paid the invoice before the last day of the show, any outstanding balance will be charged to the exhibitor's credit card.

## Exhibiting Company

\_\_\_\_\_  
Name of Exhibiting Company

\_\_\_\_\_  
Phone #

\_\_\_\_\_  
Fax #

\_\_\_\_\_  
Address

\_\_\_\_\_  
City

\_\_\_\_\_  
Prov/State

\_\_\_\_\_  
Code/Zip

\_\_\_\_\_  
Authorized Name (print)

\_\_\_\_\_  
Authorized Signature

### CREDIT CARD AUTHORIZATION

MASTERCARD  VISA  AMERICAN EXPRESS

EXPIRY DATE: \_\_\_\_\_

CORPORATE  PERSONAL

CARD #

\_\_\_\_\_  
Cardholder's Name (print)

\_\_\_\_\_  
Cardholder's Signature

## Third Party / Exhibit House

\_\_\_\_\_  
Name of Third Party/Exhibit House

\_\_\_\_\_  
Phone #

\_\_\_\_\_  
Fax #

\_\_\_\_\_  
Address

\_\_\_\_\_  
City

\_\_\_\_\_  
Prov/State

\_\_\_\_\_  
Code/Zip

\_\_\_\_\_  
Authorized Name (print)

\_\_\_\_\_  
Authorized Signature

### CREDIT CARD AUTHORIZATION

MASTERCARD  VISA  AMERICAN EXPRESS

EXPIRY DATE: \_\_\_\_\_

CORPORATE  PERSONAL

CARD #

\_\_\_\_\_  
Cardholder's Name (print)

\_\_\_\_\_  
Cardholder's Signature

**ALL GES SERVICES ARE TO BE CHARGED TO THE THIRD PARTY EXCEPT FOR THE FOLLOWING:**



5675 McLaughlin Road, Mississauga, Ontario, L5R 3K5 Tel: 905-283-0500 Fax: 905-283-0501 Toll Free: 1-877-437-4247 www.gesexpo.ca  
torontoexhibitorservices@ges.com www.gesexpo.ca

## PAYMENT POLICY INFORMATION

### **ADVANCE PRICING:**

To qualify for **Advance Pricing**, orders must be received **with payment in full on or before the deadline date.** After the Deadline Date, orders will be charged the **Regular Prices.** Orders without payment cannot be processed until payment is received and could be charged the **Regular Price.**

### **ON SITE PRICING:**

Orders placed on site (i.e. During move-in) will be charged 5% additional to the Regular Price.

### **METHOD OF PAYMENT:**

**GES** accepts American Express, MasterCard, Visa, Debit Card, Cheques, Bank Wire and Electronic Funds Transfers (EFT).

**Exhibitors will be charged a \$25.00 fee for returned NSF cheques.**

### **BANK WIRE AND ELECTRONIC FUNDS TRANSFER INFORMATION:**

To properly credit your account, please complete the **BANK WIRE / EFT FORM** included with the GES order forms.

***NOTE: There is a minimum \$20.00 Service Charge (North America) \$40.00 (International) applicable on all Wire and EFTs. Any additional Wire Transfer and EFT fees are the exhibitors responsibility and may vary depending on the processing bank.***

Please ensure the transfer is made a minimum of 10 days prior to the show.

### **PAYMENT SCHEDULE:**

Payment for all services must be pre-paid in full. **GES** will not provide Material Handling, In-Booth Forklifts, or Installation and Dismantle Labour Services without your company's **CREDIT CARD AUTHORIZATION FORM** on file.

### **THIRD PARTY BILLING:**

You may arrange for an exhibit house or Third Party to manage your exhibit and order services on your behalf. **GES** will agree to this arrangement if the exhibit house or agent makes satisfactory payment arrangements with us. In the event the authorized Third Party does not pay, each exhibiting company is ultimately responsible for all charges incurred on its behalf. See **THIRD PARTY BILLING REQUEST FORM.**

### **ADJUSTMENTS AND CANCELLATIONS:**

Adjustments to your invoice **will not be made after the close of the show.** Some items, services and labour are subject to cancellation fees. Refer to each order form for details.

**ALL EXHIBITORS MUST PAY 13% HST ON ALL ORDERS.**



**ELECTRONIC FUNDS/WIRE TRANSFER FORM**

5675 McLaughlin Road, Mississauga, Ontario, L5R 3K5 Phone: 905-283-0500 Fax: 905-283-0501

**Please complete and return this form to : Jolanta Baloniak, Accounts Receivable  
GES Exposition Services (Canada) Limited  
Email: ar@ges.com Fax: 905-283-0501**

**Your Company Name:** \_\_\_\_\_  
**Contact Name:** \_\_\_\_\_  
**Contact Number:** \_\_\_\_\_  
**Booth Number:** \_\_\_\_\_ **Event Name:** Ontario's Water Conference and Trade Show

**GES BANK INFORMATION**

PLEASE INCLUDE ALL OF THE FOLLOWING INFORMATION TO ENSURE YOUR FUNDS REACH OUR BANK

**Beneficiary's Name:** **GES Exposition Services (Canada) Limited**  
**Bank Name:** Bank of Montreal  
**Address:** 350 - 7th Avenue SW  
Calgary, AB  
T2P 3N9

IF YOU ARE SENDING  
CANADIAN DOLLARS (\$CDN)



**EFT/Direct Deposit**

Institution code #: 001  
Transit #: 00109  
Account #: 1967-990

IF YOU ARE SENDING  
AMERICAN DOLLARS (\$US)



Institution code #: 001  
Transit #: 00109  
Account #: 4773-410

**Wire Transfers**

Account #: 1967-990  
Beneficiary's Bank: //CC000100109  
Swift Code: BOFMCAM2

Account #: 4773-410  
Beneficiary's Bank: //CC000100109  
Intermediary bank: Wells Fargo Bank (FKA Wachovia)  
Swift Code: PNBPUS3NNYC

Routing / BIC / NCC / BSC or ABA Number: 026005092

**Invoice Amount:** \_\_\_\_\_

**Date of Transfer:** \_\_\_\_\_

**\*Minimum Bank Charge:** \$20.00 (North American) \$40.00 (International) \_\_\_\_\_

**Total:** \_\_\_\_\_

**Please Note:** Please ensure transfer is made by the deadline date on your Order Form or Quotation. Additional charges will be incurred for late payments, and services may be delayed. \*Minimum Bank Charges as shown above, reflect GES's bank charges only. Any additional wire transfer and EFT fees are the exhibitor's responsibility.

# furnishings

Plastic Contour Chair



Grey Fabric Side Chair



Grey Fabric Counter Stool



Grey Fabric Arm Chair



Grey Lounge Chair



Steno Chair



30" Round / 30" High Starbase Table



30" Round / 18" High Coffee Table



4' and 6' Long Skirted Counter with White Vinyl Top



4', 6', or 8' Long Skirted Table with White Vinyl Top





# furnishings

Coat Tree



22" W X 28" H  
Chrome Sign Holder  
(sign extra)

Easel



Gold Ballot Drum



Plexi Pocket  
(Wall Mountable only,  
not self-standing)



40" W x 20" D x 41" H  
White Counter Storage Unit



Bag Holder 41" H



Stanchions  
6' Belt



Plastic  
Wastebasket





# FURNISHINGS

5675 McLaughlin Road, Mississauga, Ontario, L5R 3K5 Tel: 905-283-0500 Fax: 905-283-0501 Toll Free: 1-877-437-4247

torontoexhibitorservices@ges.com www.gesexpo.ca

SHOW: **Ontario's Water Conference and Trade Show**

**ADVANCE PRICE DEADLINE DATE:**

**April 17, 2017**

## EXHIBITOR INFORMATION

**BOOTH #:** \_\_\_\_\_

COMPANY \_\_\_\_\_

STREET \_\_\_\_\_

CITY \_\_\_\_\_ PROV/STATE \_\_\_\_\_ CODE \_\_\_\_\_

E-MAIL \_\_\_\_\_

PHONE \_\_\_\_\_ FAX \_\_\_\_\_

CONTACT NAME \_\_\_\_\_

## CREDIT CARD AUTHORIZATION

MASTERCARD  VISA  AMEX

--	--	--	--	--	--	--	--	--	--

EXPIRY DATE \_\_\_\_ / \_\_\_\_

CARDHOLDER NAME

CARDHOLDER SIGNATURE

CHEQUE ATTACHED (PAYABLE TO GES CANADA)

**ALL ORDERS MUST BE PREPAID IN FULL (ORDERS CAN NOT BE PROCESSED UNTIL PAYMENT IS RECEIVED)**

QTY	Item #	Description	Advance Price	Regular Price	On Site Price	Total
	300050	Plastic Contour Chair	\$48.96	\$68.00	\$71.40	
	FGFSC	Grey Fabric Side Chair	\$54.35	\$75.48	\$79.25	
	FGFAC	Grey Fabric Arm Chair	\$68.44	\$95.06	\$99.81	
	FGFCS	Grey Fabric Counter Stool	\$95.68	\$132.89	\$139.53	
	FGFLC	Grey Lounge Chair	\$90.09	\$125.13	\$131.39	
	FSC	Steno Chair	\$92.89	\$129.01	\$135.46	
	FPEDT	Starbase Table - 30" Round x 30" High	\$97.08	\$134.83	\$141.57	
	FCOFT	Starbase Table - 30" Round x 18" High (Coffee Table)	\$74.03	\$102.82	\$107.96	
	FCT	Coat Tree	\$41.90	\$58.20	\$61.11	
	FCSH	22" x 28" Chrome Sign Holder (Sign Extra)	\$85.20	\$118.34	\$124.26	
	FESL	Easel	\$52.38	\$72.75	\$76.39	
	FSBD	Gold Ballot Drum	\$99.87	\$138.71	\$145.65	
	GPLP	Plexi Pocket (wall mountable only)	\$39.11	\$54.32	\$57.04	
	FCSU	White Counter Storage Unit 41" H	\$243.74	\$338.53	\$355.46	
	FBH	Bag Holder 41"H	\$77.52	\$107.67	\$355.46	
	FCS	1 Pair of Stanchions	\$146.66	\$203.70	\$113.05	
	FWB	Plastic Wastebasket	\$18.16	\$25.22	\$213.89	

### Terms & Conditions

- Orders received after the Advance Price Date will be processed at the Regular Price.
- Orders requested on site will be processed at the "On Site Price".
- Exhibitor is responsible for all items for the duration of the show.
- If a colour is not chosen, GES will choose a colour for you.
- Charges are for rental of equipment only. All items remain the property of GES.
- GES is not responsible for exhibit materials left in GEM rental exhibits or counter storage units.
- All claims or discrepancies must be settled at the GES Service Centre prior to show closing.
- No refunds/exchanges on cancelled skirted tables or custom booth draping once delivered.
- 50% refund on furnishings cancelled prior to show opening.

<b>SUBTOTAL</b>	
<b>13% HST</b>	
<b>TOTAL</b>	
HST #R104060264	

\_\_\_\_\_  
Signature

\_\_\_\_\_  
Date



# FURNISHINGS

5675 McLaughlin Road, Mississauga, Ontario, L5R 3K5 Tel: 905-283-0500 Fax: 905-283-0501 Toll Free: 1-877-437-4247  
torontoexhibitorservices@ges.com www.gesexpo.ca

**SHOW: Ontario's Water Conference and Trade Show**

**EXHIBITOR INFORMATION**

**BOOTH #:** \_\_\_\_\_

COMPANY \_\_\_\_\_

STREET \_\_\_\_\_

CITY \_\_\_\_\_ PROV/STATE \_\_\_\_\_ CODE \_\_\_\_\_

E-MAIL \_\_\_\_\_

PHONE \_\_\_\_\_ FAX \_\_\_\_\_

CONTACT NAME \_\_\_\_\_

**ADVANCE PRICE DEADLINE DATE:** **April 17, 2017**

**CREDIT CARD AUTHORIZATION**

MASTERCARD   
  VISA   
  AMEX

--	--	--	--	--	--	--	--

EXPIRY DATE \_\_\_\_\_ / \_\_\_\_\_

CARDHOLDER NAME \_\_\_\_\_

CARDHOLDER SIGNATURE \_\_\_\_\_

CHEQUE ATTACHED (PAYABLE TO GES CANADA)

**ALL ORDERS MUST BE PREPAID IN FULL (ORDERS CAN NOT BE PROCESSED UNTIL PAYMENT IS RECEIVED)**

QTY	Item #	SKIRTED TABLES 30" HIGH	Advance Price	Regular Price	On Site Price	Total
		<input type="checkbox"/> BLACK <input type="checkbox"/> BLUE <input type="checkbox"/> BURGUNDY <input type="checkbox"/> GREEN <input type="checkbox"/> RED <input type="checkbox"/> SILVER <input type="checkbox"/> WHITE				
	<b>DT4</b>	4 Ft. Long x 2 Ft. Wide	<b>\$91.49</b>	\$127.07	\$133.42	
	<b>DT6</b>	6 Ft. Long x 2 Ft. Wide	<b>\$108.25</b>	\$150.35	\$157.87	
	<b>DT8</b>	8 Ft. Long x 2 Ft. Wide	<b>\$136.89</b>	\$190.12	\$199.63	
	<b>DTS4</b>	Skirted Fourth Side Additional Charge	<b>\$41.21</b>	\$57.23	\$60.09	
		SKIRTED COUNTER 42" HIGH	<input type="checkbox"/> BLACK <input type="checkbox"/> BLUE <input type="checkbox"/> SILVER <input type="checkbox"/> WHITE			
	<b>RD4</b>	4 Ft. Long x 2 Ft. Wide	<b>\$136.89</b>	\$190.12	\$199.63	
	<b>RD6</b>	6 Ft. Long x 2 Ft. Wide	<b>\$155.04</b>	\$215.34	\$226.11	
	<b>RD4S</b>	Skirted Fourth Side Additional Charge	<b>\$42.60</b>	\$59.17	\$62.13	
		NON SKIRTED TABLES 30" HIGH				
	<b>UD4</b>	4 Ft. Long x 2 Ft. Wide	<b>\$67.05</b>	\$93.12	\$97.78	
	<b>UD6</b>	6 Ft. Long x 2 Ft. Wide	<b>\$87.16</b>	\$121.06	\$127.11	
	<b>UD8</b>	8 Ft. Long x 2 Ft. Wide	<b>\$100.57</b>	\$139.68	\$146.66	
		NON SKIRTED TABLES 42" HIGH				
	<b>RUD4</b>	4 Ft. Long x 2 Ft. Wide	<b>\$108.95</b>	\$151.32	\$158.89	
	<b>RUD6</b>	6 Ft. Long x 2 Ft. Wide	<b>\$141.64</b>	\$196.72	\$206.55	
		CUSTOM BOOTH DRAPING	<input type="checkbox"/> BLACK <input type="checkbox"/> BLUE <input type="checkbox"/> RED <input type="checkbox"/> SILVER <input type="checkbox"/> WHITE			
	<b>D3</b>	3 Ft. High (Per Linear Ft.)	<b>\$12.57</b>	\$17.46	\$18.33	
	<b>D8</b>	8 Ft. High (Per Linear Ft.)	<b>\$17.46</b>	\$24.25	\$25.46	

**Terms & Conditions**

- Orders received after the Advance Price Date will be processed at the Regular Price.
- Orders requested on site will be processed at the "On Site Price".
- Exhibitor is responsible for all items for the duration of the show.
- If a colour is not chosen, GES will choose a colour for you.
- Charges are for rental of equipment only. All items remain the property of GES.
- GES is not responsible for exhibit materials left in GEM rental exhibits or counter storage units.
- All claims or discrepancies must be settled at the GES Service Centre prior to show closing.
- No refunds/exchanges on cancelled skirted tables or custom booth draping once delivered.
- 50% refund on furnishings cancelled prior to show opening.

<b>SUBTOTAL</b>	
<b>13% HST</b>	
<b>TOTAL</b>	
	HST #104060264RT0001

\_\_\_\_\_  
**Signature**

\_\_\_\_\_  
**Date**



# CARPET AND UNDERPADDING

5675 McLaughlin Road, Mississauga, Ontario, L5R 3K5 Tel: 905-283-0500 Fax: 905-283-0501 Toll Free: 1-877-437-4247  
torontoexhibitorservices@ges.com www.gesexpo.ca

SHOW: <b>Ontario's Water Conference and Trade Show</b>	<b>ADVANCE PRICE DEADLINE DATE:</b>	<b>April 17, 2017</b>										
<b>EXHIBITOR INFORMATION</b>												
BOOTH #: _____												
COMPANY _____												
STREET _____												
CITY _____ PROV/STATE _____ CODE _____												
E-MAIL _____												
PHONE _____ FAX _____												
CONTACT NAME _____												
<b>CREDIT CARD AUTHORIZATION</b>												
<input type="checkbox"/> MASTERCARD <input type="checkbox"/> VISA <input type="checkbox"/> AMEX <table style="width:100%; border-collapse: collapse;"> <tr> <td style="border: 1px solid black; width: 25px; height: 20px;"></td> <td style="border: 1px solid black; width: 25px; height: 20px;"></td> <td style="border: 1px solid black; width: 25px; height: 20px;"></td> <td style="border: 1px solid black; width: 25px; height: 20px;"></td> <td style="border: 1px solid black; width: 25px; height: 20px;"></td> <td style="border: 1px solid black; width: 25px; height: 20px;"></td> <td style="border: 1px solid black; width: 25px; height: 20px;"></td> <td style="border: 1px solid black; width: 25px; height: 20px;"></td> <td style="border: 1px solid black; width: 25px; height: 20px;"></td> <td style="border: 1px solid black; width: 25px; height: 20px;"></td> </tr> </table>												
EXPIRY DATE _____ / _____												
CARDHOLDER NAME _____												
CARDHOLDER SIGNATURE _____												
<input type="checkbox"/> CHEQUE ATTACHED (PAYABLE TO GES CANADA)												

**ALL ORDERS MUST BE PREPAID IN FULL (ORDERS CAN NOT BE PROCESSED UNTIL PAYMENT IS RECEIVED)**

BOOTH CARPET - STANDARD SIZE						
Note: Exhibitors ordering multiple pieces of carpet in this section may not receive the same dyelot.						
QTY	Item #	Description	Advance Price	Regular Price	On Site Price	TOTAL
	<b>C1010</b>	10 Ft. X 10 Ft. Single Booth	<b>\$223.49</b>	\$310.40	\$325.92	
	<b>C1020</b>	10 Ft. X 20 Ft. Double Booth	<b>\$379.93</b>	\$527.68	\$554.06	
<b>COLOUR SELECTION:</b> <input type="checkbox"/> BLACK <input type="checkbox"/> BLUE <input type="checkbox"/> GREY <input type="checkbox"/> RED						

Item #	BOOTH CARPET - CUSTOM SIZE (INCLUDING PLASTIC)					
If your booth requires a size not listed above, please complete this section.						
CUSTC	BOOTH SIZE: _____ Ft. x _____ Ft.= _____ Sq. Ft.	<b>\$2.82/Sq.Ft</b>	\$3.92/Sq.Ft	\$4.11/Sq.Ft		
<b>COLOUR SELECTION:</b> <input type="checkbox"/> BLACK <input type="checkbox"/> BLUE <input type="checkbox"/> GREY <input type="checkbox"/> RED						

Item #	UNDERPADDING PRICE PER SQUARE FOOT INSTALLED (100 SQ. FT. MIN.)					
CACU	BOOTH SIZE: _____ Ft. x _____ Ft.= _____ Sq. Ft.	<b>\$1.33/Sq.Ft</b>	\$1.84/Sq.Ft	\$1.94/Sq.Ft		

Item #	PROTECTIVE PLASTIC COVERING PRICE PER SQUARE FOOT INSTALLED (STANDARD SIZES ONLY)					
CAPC	BOOTH SIZE: _____ Ft. x _____ Ft.= _____ Sq. Ft.	<b>\$0.58/Sq.Ft</b>	\$0.81/Sq.Ft	\$0.85/Sq.Ft		

PLEASE SELECT ONE FOR CUSTOM CARPET SIZES ONLY
IF ORDERING ELECTRICAL OR TELECOMMUNICATIONS SERVICES, WILL UNDER CARPET WIRING BE REQUIRED? <input type="checkbox"/> YES <input type="checkbox"/> NO

**Terms & Conditions**

- Orders received after the Advance Price Date will be processed at the Regular Price.
- Orders requested on site will be processed at the "On Site Price".
- Exhibitor is responsible for all items for the duration of the show.
- No refunds/exchanges on carpets once delivered.
- Charges are for rental of equipment only. All items remain the property of GES.
- All claims or discrepancies must be settled at the GES Service Centre prior to show closing.
- If a colour is not chosen, GES will choose a colour for you. *Carpet colour subject to availability.*

<b>SUBTOTAL</b>	
<b>13% HST</b>	
<b>TOTAL</b>	
HST #104060264RT0001	

**I have read and understand the Terms & Conditions of my Agreement with GES.**

\_\_\_\_\_  
Signature

\_\_\_\_\_  
Date

# specialty furniture

Black Ladder Stool



Equino White Stool



White Leather Stool

Red Leather Stool



Black Leather Stool

Chrome Wireback Stool



White Sculpted Leather Chair



Also available in black or red

White Sculpted Leather Loveseat

24" Square Chrome/White Cocktail Table



30" Round Cocktail Table Black Top

30" Square Cocktail Table Black Top



Throw Pillows



Available in:



Black Corbusier Leather Chair



Also available in white or red

Black Corbusier Leather Loveseat

Still can't find it? For more options please contact the Exhibitor Services Department **905.283.0500**

[torontoexhibitorservices@ges.com](mailto:torontoexhibitorservices@ges.com)

# specialty furniture

42" Round Black Meeting Table



Grey Leather Ripple Sled Base Meeting Chair



Black Leather Ripple Sled Base Meeting Chair



Bar Fridge



Literature Stand



White Meeting Chair



Round Meeting Chairs



48" Black Coffee Table



72" Chrome & White Meeting Table



48" White Coffee Table

24" Round End Table White Top



24" Round End Table Black Top



Also available in 39" round coffee tables

32" Round Coffee Table Black Top



32" Round Coffee Table White Top



Black Round Tub Chairs



White Round Tub Chairs



Still can't find it?

For more options please contact the Exhibitor Services Department **905.283.0500**

[torontoexhibitorservices@ges.com](mailto:torontoexhibitorservices@ges.com)



# SPECIALTY FURNITURE

5675 McLaughlin Road, Mississauga, Ontario, L5R 3K5 Tel: 905-283-0500 Fax: 905-283-0501 Toll Free: 1-877-437-4247  
torontoexhibitorservices@ges.com www.gesexpo.ca

**SHOW: Ontario's Water Conference and Trade Show**

**EXHIBITOR INFORMATION**

**BOOTH #:** \_\_\_\_\_

COMPANY \_\_\_\_\_

STREET \_\_\_\_\_

CITY \_\_\_\_\_ PROV/STATE \_\_\_\_\_ CODE \_\_\_\_\_

E-MAIL \_\_\_\_\_

PHONE \_\_\_\_\_ FAX \_\_\_\_\_

CONTACT NAME \_\_\_\_\_

**ADVANCE PRICE DEADLINE DATE: April 17, 2017**

**CREDIT CARD AUTHORIZATION**

MASTERCARD   
  VISA   
  AMEX

--	--	--	--	--	--	--	--

EXPIRY DATE \_\_\_\_ / \_\_\_\_

CARDHOLDER NAME \_\_\_\_\_

CARDHOLDER SIGNATURE \_\_\_\_\_

CHEQUE ATTACHED (PAYABLE TO GES CANADA)

**ALL ORDERS MUST BE PREPAID IN FULL (ORDERS CAN NOT BE PROCESSED UNTIL PAYMENT IS RECEIVED)**

QTY	Item #	Description	Advance Price	Regular Price	On Site Price	Total
	<b>SBCS</b>	Black Ladder Stool (Cloth Seat)	<b>\$155.04</b>	\$215.34	\$226.11	
	<b>SEWS</b>	Equino White Stool	<b>\$186.47</b>	\$258.99	\$271.94	
	<b>SLSW</b>	White Leather Stool	<b>\$186.47</b>	\$258.99	\$271.94	
	<b>SLSR</b>	Red Leather Stool	<b>\$186.47</b>	\$258.99	\$271.94	
	<b>SBLS</b>	Black Leather Stool	<b>\$186.47</b>	\$258.99	\$271.94	
	<b>SWBCSG</b>	Chrome Wireback Stool	<b>\$193.46</b>	\$268.69	\$282.12	
	<b>SRMCW</b>	White Round Meeting Chairs	<b>\$122.22</b>	\$169.75	\$178.24	
	<b>SRMCR</b>	Red Round Meeting Chairs	<b>\$122.22</b>	\$169.75	\$178.24	
	<b>SRMCBLK</b>	Black Round Meeting Chairs	<b>\$122.22</b>	\$169.75	\$178.24	
	<b>SCLCW</b>	White Corbusier Leather Chair	<b>\$348.50</b>	\$484.03	\$508.23	
	<b>SCLCR</b>	Red Corbusier Leather Chair	<b>\$348.50</b>	\$484.03	\$508.23	
	<b>SCLCBK</b>	Black Corbusier Leather Chair	<b>\$348.50</b>	\$484.03	\$508.23	
	<b>SCLLW</b>	White Corbusier Leather Loveseat	<b>\$410.66</b>	\$570.36	\$598.88	
	<b>SCLLR</b>	Red Corbusier Leather Loveseat	<b>\$410.66</b>	\$570.36	\$598.88	
	<b>SCLLBK</b>	Black Corbusier Leather Loveseat	<b>\$410.66</b>	\$570.36	\$598.88	
	<b>SWSC</b>	White Sculpted Leather Chair	<b>\$268.19</b>	\$372.48	\$391.10	
	<b>SSLCR</b>	Red Sculpted Leather Chair	<b>\$268.19</b>	\$372.48	\$391.10	
	<b>SSLCB</b>	Black Sculpted Leather Chair	<b>\$268.19</b>	\$372.48	\$391.10	
	<b>SWSLS</b>	White Sculpted Leather Loveseat	<b>\$364.56</b>	\$506.34	\$531.66	
	<b>SLLR</b>	Red Sculpted Leather Loveseat	<b>\$364.56</b>	\$506.34	\$531.66	
	<b>SLLB</b>	Black Sculpted Leather Loveseat	<b>\$364.56</b>	\$506.34	\$531.66	

NOTE: 3 Seater Sofa Available Upon Request. On-site orders are subject to availability.

**Terms & Conditions**

- Orders received after the Advance Price Date will be processed at the Regular Price.
- Orders requested on site will be processed at the "On Site Price".
- Exhibitor is responsible for all items for the duration of the show.
- Colours, sizes and styles may vary slightly.
- There will be no refunds/exchanges for cancellations on-site.
- Charges are for rental of equipment only. All items remain the property of GES.
- All claims or discrepancies must be settled at the GES Service Centre prior to show clos-

<b>SUBTOTAL</b>	
<b>13% HST</b>	
<b>TOTAL</b>	
HST #104060264RT0001	

\_\_\_\_\_  
**Signature**

\_\_\_\_\_  
**Date**



# SPECIALTY FURNITURE

5675 McLaughlin Road, Mississauga, Ontario, L5R 3K5 Tel: 905-283-0500 Fax: 905-283-0501 Toll Free: 1-877-437-4247  
torontoexhibitorservices@ges.com www.gesexpo.ca

**SHOW: Ontario's Water Conference and Trade Show**

**ADVANCE PRICE DEADLINE DATE: April 17, 2017**

### EXHIBITOR INFORMATION

**BOOTH #:** \_\_\_\_\_

COMPANY \_\_\_\_\_

STREET \_\_\_\_\_

CITY \_\_\_\_\_ PROV/STATE \_\_\_\_\_ CODE \_\_\_\_\_

E-MAIL \_\_\_\_\_

PHONE \_\_\_\_\_ FAX \_\_\_\_\_

CONTACT NAME \_\_\_\_\_

### CREDIT CARD AUTHORIZATION

MASTERCARD     VISA     AMEX

--	--	--	--	--	--	--	--

EXPIRY DATE \_\_\_\_\_ / \_\_\_\_\_

CARDHOLDER NAME \_\_\_\_\_

CARDHOLDER SIGNATURE \_\_\_\_\_

CHEQUE ATTACHED (PAYABLE TO GES CANADA)

### ALL ORDERS MUST BE PREPAID IN FULL (ORDERS CAN NOT BE PROCESSED UNTIL PAYMENT IS RECEIVED)

QTY	Item #	Description	Advance Price	Regular Price	On Site Price	Total
	<b>SGLMC</b>	Grey Leather Ripple Sled Base Meeting Chair	<b>\$138.28</b>	\$192.06	\$201.66	
	<b>SGLMC</b>	Black Leather Ripple Sled Base Meeting Chair	<b>\$138.28</b>	\$192.06	\$201.66	
	<b>SMCW</b>	White Meeting Chair	<b>\$134.79</b>	\$187.21	\$196.57	
	<b>SLRBTCW</b>	White Leather Round Tub Chairs	<b>\$262.60</b>	\$364.72	\$382.96	
	<b>SLRBTCBK</b>	Black Leather Round Tub Chairs	<b>\$262.60</b>	\$364.72	\$382.96	
	<b>SSWCT</b>	Chrome/White Cocktail Table (24" Square Top, 42" High)	<b>\$174.60</b>	\$242.50	\$254.63	
	<b>SRCT</b>	Round Cocktail Table (Black 30" Diameter Top, 42" High)	<b>\$191.36</b>	\$265.78	\$279.07	
	<b>SSBCT</b>	Square Cocktail Table (Black 30" Top, 42" High)	<b>\$191.36</b>	\$265.78	\$279.07	
	<b>SBMT</b>	42" Black Meeting Table (Round)	<b>\$168.31</b>	\$233.77	\$245.46	
	<b>SCMT72W</b>	72" Chrome & White Meeting Table	<b>\$270.98</b>	\$376.36	\$395.18	
	<b>SCTW</b>	24" X 48" Coffee Table White Top	<b>\$183.68</b>	\$255.11	\$267.87	
	<b>SCTB</b>	24" X 48" Coffee Table Black Top	<b>\$183.68</b>	\$255.11	\$267.87	
	<b>SWRET24</b>	24" Round End Table White Top	<b>\$145.97</b>	\$202.73	\$212.87	
	<b>SBRET24</b>	24" Round End Table Black Top	<b>\$145.97</b>	\$202.73	\$212.87	
	<b>SWRCT32</b>	Round Coffee Table White Top 32"	<b>\$164.82</b>	\$228.92	\$240.37	
	<b>SBRCT32</b>	Round Coffee Table Black Top 32"	<b>\$164.82</b>	\$228.92	\$240.37	
	<b>SWRCT39</b>	Round Coffee Table White Top 39"	<b>\$164.82</b>	\$228.92	\$240.37	
	<b>SBRCT39</b>	Round Coffee Table Black Top 39"	<b>\$164.82</b>	\$228.92	\$240.37	
	<b>SBF</b>	Bar Fridge	<b>\$228.42</b>	\$340.93	\$337.12	
	<b>SLS</b>	Literature Stand	<b>\$167.62</b>	\$232.80	\$244.44	
	<b>STP</b>	18" Throw Pillows <input type="checkbox"/> white <input type="checkbox"/> pink <input type="checkbox"/> blue <input type="checkbox"/> red <input type="checkbox"/> orange <input type="checkbox"/> yellow <input type="checkbox"/> black <input type="checkbox"/> green	<b>\$28.63</b>	\$39.77	\$41.76	

**Terms & Conditions**

- Orders received after the Advance Price Date will be processed at the Regular Price.
- Orders requested on site will be processed at the "On Site Price".
- Exhibitor is responsible for all items for the duration of the show.
- Colours, sizes and styles may vary slightly.
- There will be no refunds/exchanges for cancellations on-site.
- Charges are for rental of equipment only. All items remain the property of GES.
- All claims or discrepancies must be settled at the GES Service Centre prior to show clos-

<b>SUBTOTAL</b>	
<b>13% HST</b>	
<b>TOTAL</b>	
HST #104060264RT0001	

\_\_\_\_\_

**Signature**

\_\_\_\_\_

**Date**





# GES SHOW SPECIALS

5675 McLaughlin Road, Mississauga, Ontario, L5R 3K5 Tel: 905-283-0500 Fax: 905-283-0501 Toll Free: 1-877-437-4247 www.gesexpo.ca  
torontoexhibitorservices@ges.com www.gesexpo.ca

<b>SHOW: Ontario's Water Conference and Trade Show</b>	<b>ADVANCE PRICE DEADLINE DATE: April 17, 2017</b>												
<b>EXHIBITOR INFORMATION</b>	<b>CREDIT CARD AUTHORIZATION</b>												
<b>BOOTH #:</b> _____ COMPANY _____ STREET _____ CITY _____ PROV/STATE _____ CODE _____ E-MAIL _____ PHONE _____ FAX _____ CONTACT NAME _____	<input type="checkbox"/> MASTERCARD <input type="checkbox"/> VISA <input type="checkbox"/> AMEX <table border="1" style="width:100%; height: 20px; border-collapse: collapse;"> <tr> <td style="width: 25px;"> </td><td style="width: 25px;"> </td><td style="width: 25px;"> </td><td style="width: 25px;"> </td> <td style="width: 25px;"> </td><td style="width: 25px;"> </td><td style="width: 25px;"> </td><td style="width: 25px;"> </td> <td style="width: 25px;"> </td><td style="width: 25px;"> </td><td style="width: 25px;"> </td><td style="width: 25px;"> </td> </tr> </table> EXPIRY DATE ____ / ____ CARDHOLDER NAME _____ CARDHOLDER SIGNATURE _____ <input type="checkbox"/> CHEQUE ATTACHED (PAYABLE TO GES CANADA)												

**GES SHOW SPECIAL INCLUDES:**  
 • Header Sign(s) - 12"x77.5" • Infill Panels • Carpet • Installed & Dismantled • No Labour Costs • No Material Handling Costs

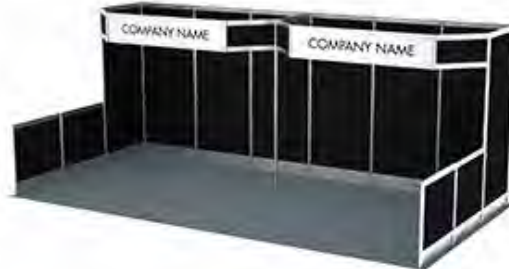

(No substitutions please. If you require additional furniture, please refer to the GES order forms enclosed in the manual).

QTY	Item #	Description	Advance Price	Regular Price	On Site Price	Total
	<b>SS001</b>	Package A - 10' x 10'	<b>\$942.14</b>	\$1,308.53	\$1,373.96	
	<b>SS002</b>	Package B - 10' x 20'	<b>\$1,413.56</b>	\$1,963.28	\$2,061.44	

<b>PLEASE SELECT YOUR CHOICE OF INFILL PANEL AND CARPET COLOUR:</b>
Infill Panel Colour: <input type="checkbox"/> Black <input type="checkbox"/> Grey <input type="checkbox"/> White       Carpet Colour: <input type="checkbox"/> Black <input type="checkbox"/> Grey <i>(All panel &amp; carpet colours subject to availability.)</i>
Package A Identification Sign to Read: _____ Package B Identification Sign to Read: Left: _____ Right: _____ Custom Header to be added <input type="checkbox"/> Custom Header Signs/Logos will be charged \$100.00 extra per sign You can upload your file(s) to: <a href="https://file.ges.com/">https://file.ges.com/</a> Enter <a href="mailto:tupload@ges.com">tupload@ges.com</a> in the "Recipient Email Address" field. <b>IMPORTANT:</b> Please enter your company name, event name, event location, booth number, and any other specifics associated with your graphic file under "Comments:"

**Terms & Conditions**

- Orders received after the Advance Price Date will be processed at the Regular Price.
- Orders requested on site will be processed at the "On site Price".
- Does not include lighting or electrical service.
- No refunds/exchanges once show move-in begins.
- All claims or discrepancies must be settled prior to show closing.
- GES is not responsible for exhibit materials left in GES Rental Exhibits or counter storage units.
- Changes to the structure design or graphics will result in additional fees.

<b>SUBTOTAL</b>	
<b>13% HST</b>	
<b>TOTAL</b>	
HST #104060264RT0001	

**I have read and understand the Terms & Conditions of my Agreement with GES.**

\_\_\_\_\_  
Signature

\_\_\_\_\_  
Date



# standard exhibit rentals

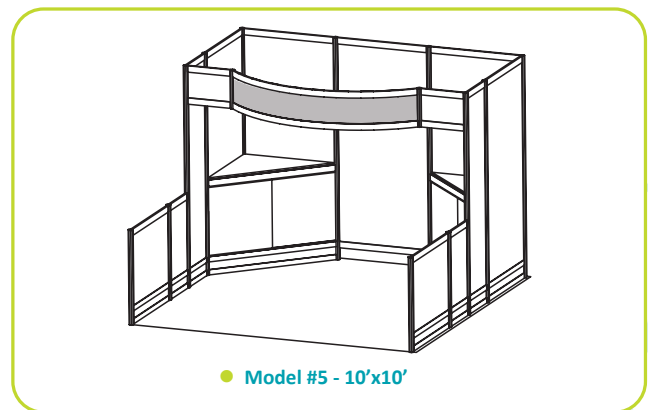
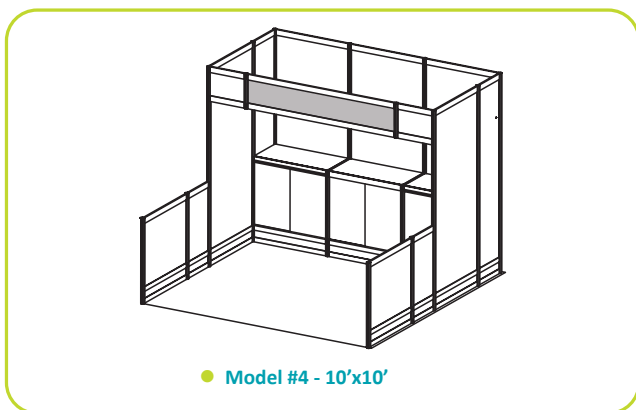
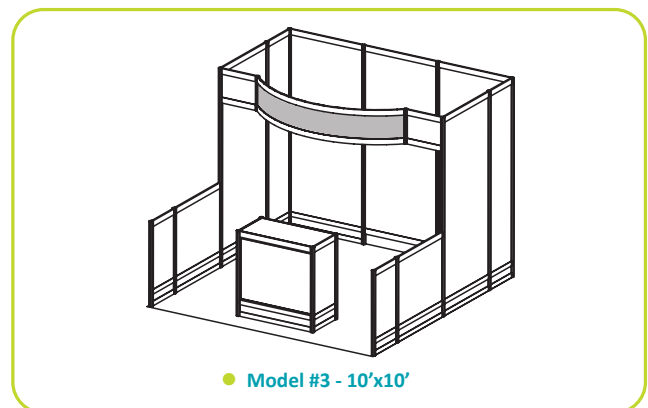
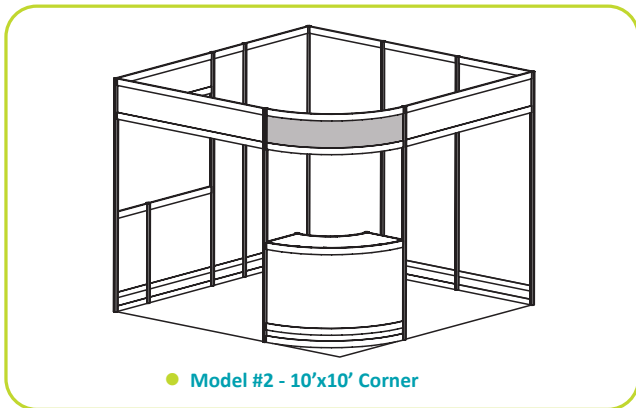
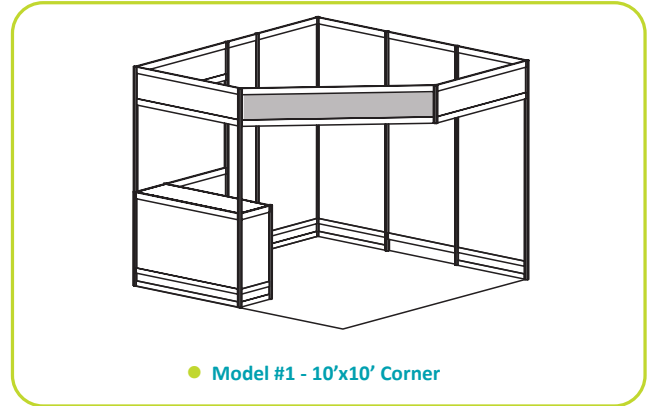

## 3 Easy Steps →

- 1 Select the model number that suits your needs
- 2 Choose carpet and panel colours on the Standard Modular Exhibit form
- 3 Complete & send order form

Grey indicates standard header sign(s)



# standard exhibit rentals

**10' X 20'**  
**EXHIBITS**

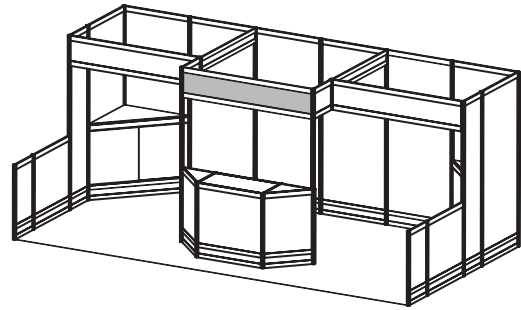

● Model #6 - 10'x20'

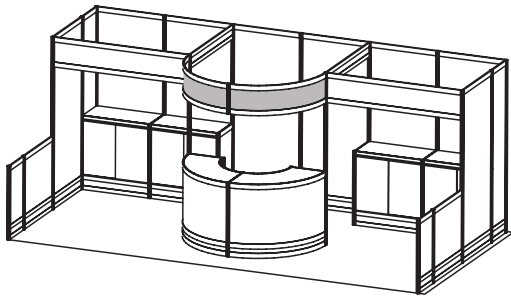

● Model #7 - 10'x20'

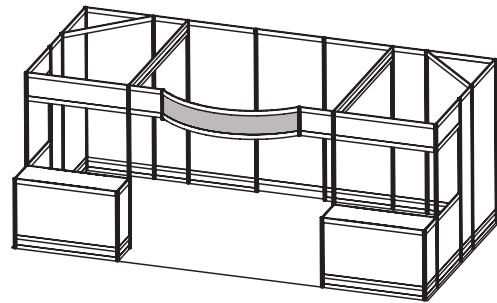

● Model #8 - 10'x20'

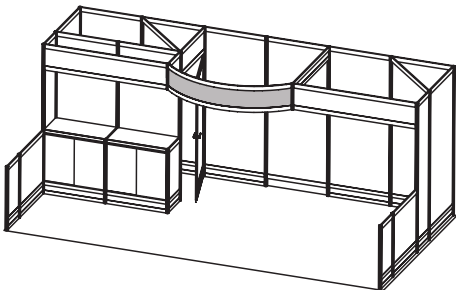

● Model #9 - 10'x20'

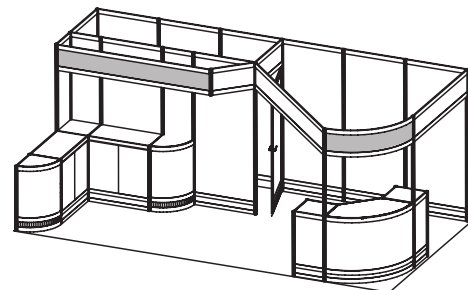

● Model #10 - 10'x20' Corner

## 3 Easy Steps

- 1 Select the model number that suits your needs
- 2 Choose carpet and panel colours on the Standard Modular Exhibit form
- 3 Complete & send order form

Grey indicates standard header sign(s)

5675 McLaughlin Road, Mississauga, Ontario, L5R 3K5 Tel: 905-283-0500 Fax: 905-283-0501 Toll Free: 1-877-437-4247  
torontoexhibitorservices@ges.com www.gesexpo.ca

<b>SHOW: Ontario's Water Conference and Trade Show</b>	<b>ADVANCE PRICE DEADLINE DATE: April 17, 2017</b>										
<b>EXHIBITOR INFORMATION</b>											
<b>BOOTH #:</b> _____ COMPANY _____ STREET _____ CITY _____ PROV/STATE _____ CODE _____ E-MAIL _____ PHONE _____ FAX _____ CONTACT NAME _____											
<b>CREDIT CARD AUTHORIZATION</b>											
<input type="checkbox"/> MASTERCARD <input type="checkbox"/> VISA <input type="checkbox"/> AMEX <table style="width:100%; border-collapse: collapse;"> <tr> <td style="border: 1px solid black; width: 25px; height: 20px;"></td> <td style="border: 1px solid black; width: 25px; height: 20px;"></td> <td style="border: 1px solid black; width: 25px; height: 20px;"></td> <td style="border: 1px solid black; width: 25px; height: 20px;"></td> <td style="border: 1px solid black; width: 25px; height: 20px;"></td> <td style="border: 1px solid black; width: 25px; height: 20px;"></td> <td style="border: 1px solid black; width: 25px; height: 20px;"></td> <td style="border: 1px solid black; width: 25px; height: 20px;"></td> <td style="border: 1px solid black; width: 25px; height: 20px;"></td> <td style="border: 1px solid black; width: 25px; height: 20px;"></td> </tr> </table> EXPIRY DATE _____ / _____  CARDHOLDER NAME _____  CARDHOLDER SIGNATURE _____ <input type="checkbox"/> CHEQUE ATTACHED (PAYABLE TO GES CANADA)											

**ALL ORDERS MUST BE PREPAID IN FULL (ORDERS CAN NOT BE PROCESSED UNTIL PAYMENT IS RECEIVED)**

Item #	Advance Price	Regular Price	On Site Price	Item #	Advance Price	Regular Price	On Site Price
GEM001	<b>\$1,952.73</b>	\$2,712.12	\$2,847.73	GEM006	<b>\$4,129.64</b>	\$5,735.61	\$6,022.39
GEM002	<b>\$1,730.64</b>	\$2,403.66	\$2,523.84	GEM007	<b>\$4,273.51</b>	\$5,935.43	\$6,232.20
GEM003	<b>\$2,060.98</b>	\$2,862.47	\$3,005.59	GEM008	<b>\$3,982.28</b>	\$5,530.94	\$5,807.49
GEM004	<b>\$2,472.34</b>	\$3,433.80	\$3,605.49	GEM009	<b>\$4,189.70</b>	\$5,819.03	\$6,109.98
GEM005	<b>\$2,293.55</b>	\$3,185.48	\$3,344.75	GEM010	<b>\$4,704.42</b>	\$6,533.92	\$6,860.62

Package Includes: Installation & Dismantling, Choice of Carpet Colour, Choice of Panel Colour, Company Identification Sign

**Package Does Not Include: Cleaning, Light Fixtures or Electrical Outlets**

**PLEASE SELECT YOUR CHOICE OF INFILL PANEL AND CARPET COLOUR**

Upgrade options available. Contact Exhibitor Services.  
Other panel colours available upon request. Contact Exhibitor Services.  
(All panel & carpet colours subject to availability.)

ITEM #:

Infill Panel Colour:  Black     Grey     White      Carpet Colour:  Black     Blue     Grey     Red

Models 1, 2, 3, 4, 5, 6, 8 or 9 Identification Sign to Read: \_\_\_\_\_

Models 7 or 10 Identification Sign to Read: Left: \_\_\_\_\_ Right: \_\_\_\_\_

Indicate Date & Time for Arrival: \_\_\_\_\_

Custom Header to be added  Custom Header Signs/Logos will be charged \$100.00 extra per sign

You can upload your file(s) to: <https://file.ges.com/>

Enter **toupload@ges.com** in the "Recipient Email Address" field.

**IMPORTANT:** Please enter your company name, event name, event location, booth number, and any other specifics associated with your graphic file under "Comments:"

**Terms & Conditions**

- Payment may be made by cheque up to two weeks prior to the 1<sup>st</sup> day of move in.
- All orders received after the Advance Price Date will be processed at the Regular Price.
- Exhibitor is responsible for all items for the duration of the show.
- Charges are for rental of equipment only. All items remain the property of GES.
- No refunds/exchanges once show move-in begins. All claims or discrepancies must be settled prior to show closing.
- GES is not responsible for exhibit materials left in GES Rental Exhibits or counter storage units.
- Changes to the structure design or graphics will result in additional fees.

<b>SUBTOTAL</b>	
<b>13% HST</b>	
<b>TOTAL</b>	
HST #104060264RT0001	

**I have read and understand the Terms & Conditions of my Agreement with GES.**

\_\_\_\_\_  
Signature

\_\_\_\_\_  
Date

**Our Creative Exhibit Team will design a cost-effective, turnkey exhibit that will**

- ☉ Exceed your expectations
- ☉ Highlight your brand
- ☉ Attract positive attention
- ☉ Stay within your budget

**Your successful Tradeshow is just a phone call or click away...**

*Jodi Anastasakis* ☉ 905-283-0559  
☉ [janastasakis@ges.com](mailto:janastasakis@ges.com)





# GES EXHIBIT ACCESSORIES

5675 McLaughlin Road, Mississauga, Ontario, L5R 3K5 Tel: 905-283-0500 Fax: 905-283-0501 Toll Free: 1-877-437-4247  
torontoexhibitorservices@ges.com www.gesexpo.ca

SHOW: **Ontario's Water Conference and Trade Show**

**ADVANCE PRICE DEADLINE DATE:**

**April 17, 2017**

## EXHIBITOR INFORMATION

**BOOTH #:** \_\_\_\_\_

COMPANY \_\_\_\_\_

STREET \_\_\_\_\_

CITY \_\_\_\_\_ PROV/STATE \_\_\_\_\_ CODE \_\_\_\_\_

E-MAIL \_\_\_\_\_

PHONE \_\_\_\_\_ FAX \_\_\_\_\_

CONTACT NAME \_\_\_\_\_

## CREDIT CARD AUTHORIZATION

MASTERCARD  VISA  AMEX

--	--	--	--	--	--	--	--	--	--

EXPIRY DATE \_\_\_\_ / \_\_\_\_

CARDHOLDER NAME

CARDHOLDER SIGNATURE

CHEQUE ATTACHED (PAYABLE TO GES CANADA)

**ALL ORDERS MUST BE PREPAID IN FULL (ORDERS CAN NOT BE PROCESSED UNTIL PAYMENT IS RECEIVED)**

QTY	Item #	Description	Advance Price	Regular Price	On Site Price	Total
	PED001	Pedestal (White) 20"L x 20"W 28"H	\$143.17	\$198.85	\$208.79	
	PED002	Pedestal (White) 20"L x 20"W 36"H	\$149.46	\$207.58	\$217.96	
	GPML	Pedestal White 40"L X 40"W (Tops are 20" X 20") (Unit Heights - 16"- 28" & 28"- 40")	\$549.64	\$763.39	\$801.56	
	GSC	Storage Counter (White) 80"L X 20"W X 40"H	\$453.96	\$630.50	\$662.03	
	GCC	Curved Counter (White) 60"L X 20"W X 40"H	\$361.07	\$501.49	\$526.56	
	F99A	Showcase (White/Glass) 40"L X 20"W X 41"H	\$361.07	\$501.49	\$526.56	
	F99B	Showcase (White/Glass) 40"L X 20"W X 41"H	\$361.07	\$501.49	\$526.56	
	F99C	Showcase (White/Glass) 26"L X 26"W X 96"H	\$545.45	\$757.57	\$795.45	
	F99D	Showcase (White/Glass) 40"L X 20"W X 96"H	\$545.45	\$757.57	\$795.45	



QTY	Item #	Description	Advance Price	Regular Price	On Site Price	Total
	GWF	Waterfall With Eight Hooks	\$44.70	\$62.08	\$65.18	
	GGP	Grid Panels - 38"W X 44"H White Panels	\$149.46	\$207.58	\$217.96	
	GGR	Garment Rail 39"W	\$53.08	\$73.72	\$77.41	
	GFS	Shelves - Flat 37"L X 12"W	\$45.40	\$63.05	\$66.20	
	GAS	Shelves - Angled 37"L X 12"W	\$45.40	\$63.05	\$66.20	
	GSWP	Slatwall Panels - 37"W X 96"H Grey (Upgrade for standard panels)	\$126.41	\$175.57	\$184.35	



*Designed to fit GES Hardwall booths only.  
Please Attach Diagram Of Booth Indicating Locations For Grid Panels And/Or Slatwall.  
Grid Panels Cannot Be Installed In Corners.*

### Terms & Conditions

- All orders received after the Advance Price Date will be processed at the Regular Price.
- Orders requested on site will be processed at the "On Site Price".
- All claims or discrepancies must be settled prior to show closing.
- Exhibitor is responsible for all items for the duration of the show.
- Charges are for rental of equipment. All items remain the property of GES.
- All claims or discrepancies must be settled at the GES Service Centre prior to show closing.
- No refunds/exchanges once show move-in begins.
- All items subject to availability.

<b>SUBTOTAL</b>	
<b>13% HST</b>	
<b>TOTAL</b>	
HST #104060264RT0001	

**I have read and understand the Terms & Conditions of my Agreement with GES.**

\_\_\_\_\_  
**Signature**

\_\_\_\_\_  
**Date**

GES is your one stop exhibit solution partner. Take advantage of our Creative Services Department to enhance your presence on the show floor. Upgrade a show special, or design from scratch. Our team of in-house Designers & Production Technicians, can help you realize your vision quickly and affordably.



- Backlit signs
- Banners & hanging signs
- Floor/carpet decals
- Backwall murals
- Easel & freestanding signs
- Posters
- Custom cut signs & decals
- Branding graphics

Please contact Jodi Anastasakis: 905.283.0559

or email: [janastasakis@ges.com](mailto:janastasakis@ges.com)



# GRAPHICS AND DESIGN

5675 McLaughlin Road, Mississauga, Ontario, L5R 3K5 Tel: 905-283-0500 Fax: 905-283-0501 Toll Free: 1-877-437-4247  
torontoexhibitorservices@ges.com www.gesexpo.ca

<b>SHOW: Ontario's Water Conference and Trade Show</b>	<b>ADVANCE PRICE DEADLINE DATE: April 17, 2017</b>				
<b>EXHIBITOR INFORMATION</b>	<b>CREDIT CARD AUTHORIZATION</b>				
<b>BOOTH #:</b> _____ COMPANY _____ STREET _____ CITY _____ PROV/STATE _____ CODE _____ E-MAIL _____ PHONE _____ FAX _____ CONTACT NAME _____	<input type="checkbox"/> MASTERCARD <input type="checkbox"/> VISA <input type="checkbox"/> AMEX <table border="1" style="width:100%; height: 20px; border-collapse: collapse;"> <tr> <td style="width: 25%;"></td> <td style="width: 25%;"></td> <td style="width: 25%;"></td> <td style="width: 25%;"></td> </tr> </table> EXPIRY DATE ____ / ____ / ____ _____ CARDHOLDER NAME _____ CARDHOLDER SIGNATURE <input type="checkbox"/> CHEQUE ATTACHED (PAYABLE TO GES CANADA)				

**ALL ORDERS MUST BE PREPAID IN FULL (ORDERS CAN NOT BE PROCESSED UNTIL PAYMENT IS RECEIVED)**

## CUSTOM GRAPHICS

### We offer complete graphics services from Design to Print!

We can create custom graphics almost any size to fit any of your needs, including:

- Pressure sensitive vinyl (PSV) Booth wraps (the same as vehicle wraps)
- Vinyl or mesh banners for use in your booth
- Backlit graphics for lightboxes and display cases
- Custom fit / contour cut graphics for eye-catching effects
- Printing on specialized / unique materials
- Double sided applications
- Carpet / Floor Decals

For more information or a quote, please email us at [torontoexhibitorservices@ges.com](mailto:torontoexhibitorservices@ges.com)

## PER SQ. FT. PRICE

Item #	Description	Advance	Regular	On Site
SIG022	1/8" PVC s/s	\$7.98	\$11.08	\$12.75
SIG023	Coroplast s/s	\$6.35	\$8.82	\$10.14
SIG024	1/2" Gatorfoam	\$12.28	\$17.06	\$19.62
SIG025	Banner s/s	\$5.93	\$8.24	\$9.48
SIG026	Poster paper	\$5.61	\$7.79	\$8.95
CRT01	Design time (per hour)	\$73.42	\$101.97	\$117.27

\* All prices include delivery to show site.

Please upload artwork here:  
<https://file.ges.com/>  
 Use "Recipient email address":  
[toupload@ges.com](mailto:toupload@ges.com)

**IMPORTANT NOTE:**  
 Make sure to included the your company name, event, and booth number under "comments".

## STANDARD SIGN PRICE LIST

Item #	Description	Advance	Regular	On Site
SIG027	8"W x 11"H vertical sign (with easel)	\$13.75	\$19.10	\$21.96
S744	44"W x 7"H horizontal sign (with holes)	\$75.43	\$104.76	\$110.00
S2228	22"W x 28"H vertical sign	\$101.97	\$141.62	\$148.70
S2844	28"W x 44"H vertical sign	\$131.30	\$182.36	\$191.48
SIG028	38"W x 84"H vertical sign (with feet)	\$498.19	\$691.92	\$795.71

\* All prices include delivery to show site.

## PLACE ORDER HERE

Item #	Description	Price	Qty	Total
				\$
				\$
				\$
				\$
				\$
A.	Subtotal			\$
B.	13% HST (HST# 104060264RT0001)			\$
C.	Total			\$
I agree in placing this order that I have read and accepted GES Payment Policy and GES Terms & Conditions.				
Authorized Signature - Please Sign: <b>X</b>				
AUTHORIZED NAME - PLEASE PRINT				DATE

### Terms & Conditions

- Orders received after the Advance Price Date will be processed at the Regular Price.
- Orders requested on site will be processed at the "On Site Price".
- There are no refunds/exchanges on signs.
- All claims or discrepancies must be settled at the GES Service Centre prior to show closing.

## SIGN INFO

\*If you do not have a print file to submit, but need copy to be set/basic layout please write in the text and description for your sign order below or attach seperate page.

**ALL SIGNS MUST BE PICKED UP FROM OUR ON-SITE EXHIBITOR SERVICES DESK.**





# PLANTS AND FLOWERS

5675 McLaughlin Road, Mississauga, Ontario, L5R 3K5 Tel: 905-283-0500 Fax: 905-283-0501 Toll Free: 1-877-437-4247  
torontoexhibitorservices@ges.com www.gesexpo.ca

SHOW: <b>Ontario's Water Conference and Trade Show</b>	<b>ADVANCE PRICE DEADLINE DATE:</b> <b>April 17, 2017</b>
<b>EXHIBITOR INFORMATION</b>	<b>CREDIT CARD AUTHORIZATION</b>
BOOTH #: _____	<input type="checkbox"/> MASTERCARD <input type="checkbox"/> VISA <input type="checkbox"/> AMEX
COMPANY _____	_____
STREET _____	EXPIRY DATE _____ / _____
CITY _____ PROV/STATE _____ CODE _____	CARDHOLDER NAME _____
E-MAIL _____	CARDHOLDER SIGNATURE _____
PHONE _____ FAX _____	<input type="checkbox"/> CHEQUE ATTACHED (PAYABLE TO GES CANADA)
CONTACT NAME _____	

**ALL ORDERS MUST BE PREPAID IN FULL (ORDERS CAN NOT BE PROCESSED UNTIL PAYMENT IS RECEIVED)**

FLOOR AND TABLE PLANTS						
QTY	Item #	Description	Advance Price	Regular Price	On Site Price	Total
	PFP25	2 ft. to 5 ft. Tall	<b>\$85.90</b>	\$119.31	\$125.28	
	PFP68	6 ft. to 8 ft. Tall	<b>\$167.62</b>	\$232.80	\$244.44	
	PFP910	9 ft. to 10 ft. Tall (Indoor Tree)	<b>\$251.42</b>	\$349.20	\$366.66	
	PBF	Boston Fern	<b>\$62.86</b>	\$87.30	\$91.67	
	PTP	Table Plant - 10"	<b>\$62.86</b>	\$87.30	\$91.67	
	PMUM	Mums	<b>\$37.71</b>	\$52.38	\$55.00	
FLOWER ARRANGEMENTS						
	PFFAS	Standard Fresh Flower Arrangement	<b>\$123.62</b>	\$171.69	\$180.27	
	PFFAP	Premium Fresh Flower Arrangement	<b>\$228.38</b>	\$317.19	\$333.05	
	PFFAE	Exotic Arrangement	<b>\$157.14</b>	\$218.25	\$229.16	



**PLEASE NOTE:** Prices for flowering plants may change depending on type of flowers requested. Please list below the types of flowers you require along with any specific instructions and our Exhibitor Service Department will check on availability and price:

**Terms & Conditions**

- Orders received after the Advance Price Date will be processed at the Regular Price.
- Orders requested on site will be processed at the "On Site Price".
- Exhibitor is responsible for all items for the duration of the show.
- No refunds, exchanges or cancellations on site.
- Charges are for rental of equipment only. All items remain the property of GES.
- All claims or discrepancies must be settled at the GES Service Centre prior to show closing.

<b>SUBTOTAL</b>	
<b>13% HST</b>	
<b>TOTAL</b>	
	HST #104060264RT0001

**I have read and understand the Terms & Conditions of my Agreement with GES.**

\_\_\_\_\_  
Signature

\_\_\_\_\_  
Date



**LABOUR  
INSTALLATION AND DISMANTLING**

5675 McLaughlin Road, Mississauga, Ontario, L5R 3K5 Tel: 905-283-0500 Fax: 905-283-0501 Toll Free: 1-877-437-4247  
torontoexhibitorservices@ges.com www.gesexpo.ca

SHOW: <b>Ontario's Water Conference and Trade Show</b>	<b>ADVANCE PRICE DEADLINE DATE:</b> <b>April 17, 2017</b>												
<b>EXHIBITOR INFORMATION</b>	<b>CREDIT CARD AUTHORIZATION</b>												
BOOTH #: _____	<input type="checkbox"/> MASTERCARD <input type="checkbox"/> VISA <input type="checkbox"/> AMEX												
COMPANY _____	<table border="1" style="width:100%; border-collapse: collapse; text-align: center;"> <tr> <td style="width:25px;"> </td><td style="width:25px;"> </td><td style="width:25px;"> </td><td style="width:25px;"> </td> <td style="width:25px;"> </td><td style="width:25px;"> </td><td style="width:25px;"> </td><td style="width:25px;"> </td> <td style="width:25px;"> </td><td style="width:25px;"> </td><td style="width:25px;"> </td><td style="width:25px;"> </td> </tr> </table>												
STREET _____	EXPIRY DATE _____ / _____												
CITY _____ PROV/STATE _____ CODE _____	CARDHOLDER NAME _____												
E-MAIL _____	CARDHOLDER SIGNATURE _____												
PHONE _____ FAX _____	<input type="checkbox"/> CHEQUE ATTACHED (PAYABLE TO GES CANADA)												
CONTACT NAME _____													

**EXHIBITOR MUST REPORT TO GES SERVICE CENTRE TO RECEIVE THEIR LABOUR**

LABOUR RATES ARE CHARGED PER PERSON AT **A MINIMUM CHARGE OF ONE HOUR**. LABOUR OVER ONE HOUR IS CHARGED IN 1/2 HOUR INCREMENTS.  
(A 30% SURCHARGE WILL BE APPLIED TO ON-SITE ORDERS)

**LABOUR INSTALLATION AND DISMANTLING**

Item #	Item #	DESCRIPTION	PER HOUR
LINREG	LOREG	Straight Time Monday-Friday 8:00am - 4:00pm	<b>\$113.30</b>
LINOT	LOOT	Over Time Monday-Friday 4:00pm - 6:00pm, Saturday & Sunday 8:00am - 4:00pm	<b>\$170.98</b>
LINDT	LODT	Double Time Monday-Friday After 6:00pm, Saturday & Sunday After 4:00pm, All Holiday Hours	<b>\$221.45</b>

<b>INSTALLATION</b>	Set Up Drawings or Photos Attached: <input type="checkbox"/> yes <input type="checkbox"/> no
Carrier: _____	Delivery Date/Time: _____ AM PM <small>Day / Date/ Month / Year</small>
<b>SUPERVISION</b>	<input type="checkbox"/> By Exhibitor (Provide Name of Rep): _____ <input type="checkbox"/> By GES <b>30% surcharge applies</b> <small>(Exhibitor <u>MUST</u> be Present to Supervise) (Exhibitor does <u>NOT</u> have to be present)</small>
<b>DATE/TIME LABOUR REQUIRED:</b> _____	AM PM <small>Day / Date/ Month / Year</small>
<b>NUMBER OF PEOPLE REQUIRED</b> _____	<b>X HOURS PER PERSON</b> _____ = <b>TOTAL EST. HRS.</b> _____
<b>DISMANTLING</b>	
Carrier: _____	Delivery Date/Time: _____ AM PM <small>Day / Date/ Month / Year</small>
<b>SUPERVISION</b>	<input type="checkbox"/> By Exhibitor (Provide Name of Rep): _____ <input type="checkbox"/> By GES <b>30% surcharge applies</b> <small>(Exhibitor <u>MUST</u> be Present to Supervise) (Exhibitor does <u>NOT</u> have to be present)</small>
<b>DATE/TIME LABOUR REQUIRED:</b> _____	AM PM <small>Day / Date/ Month / Year</small>
<b>NUMBER OF PEOPLE REQUIRED</b> _____	<b>X HOURS PER PERSON</b> _____ = <b>TOTAL EST. HRS.</b> _____

**Terms & Conditions**

- When Exhibitor is supervising labour the Exhibitor must check labour in and out at the GES Service Centre.
- We reserve the right to change labourers and/or rates as shifts change.
- All claims or discrepancies must be settled within one week of show closing.
- Uncancelled labour will be charged a minimum fee of 1 hour per person.
- GES Limits of Liability apply.

<b>EST. SUBTOTAL</b>	
<b>13% HST</b>	
<b>EST. TOTAL</b>	
	HST #104060264RT0001

**I have read and understand the Terms & Conditions of my Agreement with GES.**

\_\_\_\_\_  
Signature

\_\_\_\_\_  
Date



5675 McLaughlin Road, Mississauga, Ontario, L5R 3K5 Tel: 905-283-0500 Fax: 905-283-0501 Toll Free: 1-877-437-4247 www.gesexpo.ca

## **IMPORTANT – PLEASE READ CAREFULLY**

### **MATERIAL HANDLING SERVICE INFORMATION**

Exhibitors are permitted to receive and unload their own shipment(s) providing a representative of their company is present to receive the shipment(s) at the time of delivery, and they are able to unload their shipment(s) without the use of a forklift.

**If unable to meet these requirements, GES has been appointed by Show Management to perform these services for Ontario's Water Conference and Trade Show at the expense of the exhibitor.**

Material Handling services are billed per each shipment received, per each forklift used, based on a 1 hour minimum charge (including move in and move out).

**Please note: billing is based on Straight Time, Over Time or Double Time depending on the date and time the shipment(s) are received.**

#### **Material Handling Service Includes**

- UNLOADING OF YOUR CARRIER & DELIVERY TO YOUR BOOTH
- REMOVING OF EMPTY CONTAINERS/CRATES/SKIDS FROM BOOTH TO STORAGE
- RETURNING OF EMPTY CONTAINERS/CRATES/SKIDS TO BOOTH AFTER SHOW
- RETURN OF YOUR CONTAINERS/CRATES/SKIDS TO THE LOADING DOCK
- RELOADING OF SHIPMENT(S) FROM DOCK TO CARRIER

If this additional service is required please fill out the **Material Handling Order Form included in this kit.**

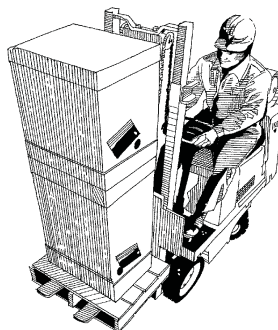



**MATERIAL HANDLING HOURLY**

5675 McLaughlin Road, Mississauga, Ontario, L5R 3K5 Tel: 905-283-0500 Fax: 905-283-0501 Toll Free: 1-877-437-4247  
torontoexhibitorservices@ges.com www.gesexpo.ca

SHOW: **Ontario's Water Conference and Trade Show**

**ADVANCE PRICE DEADLINE DATE:** **April 17, 2017**

**EXHIBITOR INFORMATION**

**BOOTH #:** \_\_\_\_\_

COMPANY \_\_\_\_\_

STREET \_\_\_\_\_

CITY \_\_\_\_\_ PROV/STATE \_\_\_\_\_ CODE \_\_\_\_\_

E-MAIL \_\_\_\_\_

PHONE \_\_\_\_\_ FAX \_\_\_\_\_

CONTACT NAME \_\_\_\_\_

**CREDIT CARD AUTHORIZATION**

MASTERCARD  VISA  AMEX

--	--	--	--	--	--	--	--	--	--	--	--

EXPIRY DATE \_\_\_\_\_ / \_\_\_\_\_

CARDHOLDER NAME \_\_\_\_\_

CARDHOLDER SIGNATURE \_\_\_\_\_

CHEQUE ATTACHED (PAYABLE TO GES CANADA)

**CREDIT CARD AUTHORIZATION (ABOVE) MUST BE COMPLETED AS METHOD OF PAYMENT FOR THIS SERVICE**

MATERIAL HANDLING SERVICE WILL BE AVAILABLE TO ASSIST EXHIBITORS WITH IN AND OUT HANDLING OF EXHIBITOR MATERIALS AT A **MINIMUM CHARGE OF ONE HOUR** PER SHIPMENT PER FORKLIFT DRIVER. SERVICES OVER 1 HOUR WILL BE CHARGED IN 1/2 HOUR INCREMENTS. (INCLUDES MOVE-IN AND MOVE-OUT).

**THIS SERVICE IS NOT PAID FOR BY SHOW MANAGEMENT**

**All Rates Include Forklift Driver**

**MATERIAL HANDLING HOURLY**

Item #	Item #	DESCRIPTION	PER HOUR
MHIRF	MHORF	Straight Time Monday-Friday 8:00am - 4:00pm	<b>\$238.96</b>
MHIOTF	MHOOTF	Over Time Monday-Friday 4:00pm - 6:00pm, Saturday & Sunday 8:00am - 4:00pm	<b>\$287.37</b>
MHIDTF	MHODTF	Double Time Monday-Friday After 6:00pm, Saturday & Sunday After 4:00pm, All Holiday Hours	<b>\$340.93</b>

- A 30% SURCHARGE WILL APPLY TO THE FOLLOWING:**
- Shipments that are uncrated, stacked, pad-wrapped or contain loose pieces.
  - Material Handling orders placed on-site.

**PLEASE COMPLETE THE FOLLOWING:**

Goods are scheduled for delivery to:  Show Site  Advance Warehouse

Date goods are scheduled to arrive: \_\_\_\_\_ Total Weight: \_\_\_\_\_ lbs. \_\_\_\_\_ kg.  
Month/Day

Carrier Name: \_\_\_\_\_ Number of Pieces: \_\_\_\_\_

- Terms & Conditions**
- Collect shipments will not be accepted.
  - GES is not responsible for concealed damage, damage to loose or inadequately packed shipments or loss of merchandise after delivery to booth.
  - It is the exhibitor's responsibility to secure and maintain loss & damage insurance coverage for their exhibit properties.
  - All claims or discrepancies must be settled at the GES Service Centre prior to show closing.
  - GES Limits of Liability & Responsibility apply to this service.

<b>SUBTOTAL</b>	_____
<b>13% HST</b>	_____
<b>TOTAL</b>	_____
HST #104060264RT0001	

I have read and understand the Terms & Conditions of my Agreement with GES.

\_\_\_\_\_  
Signature

\_\_\_\_\_  
Date

1. GES CANADA Exposition Services herein known as GES and its subcontractors shall not be responsible for damage to uncrated materials; materials improperly packed, glass breakage or concealed damage.

2. Relative to inbound shipments, there may be a lapse of time between the delivery of shipment(s) to the booth by GES or its subcontractors and the arrival of the Exhibitor's representative at the booth. Similarly, relative to outgoing shipment(s), it is possible that there will be a lapse of time between the completion of packing and the actual pick-up of materials from the booth for loading onto a carrier. It is understood that during such times the shipment(s) will be left in the booth unattended.

Therefore, it is agreed that GES and its subcontractors are not responsible for the loss or disappearance of Exhibitor's materials after the same have been delivered to Exhibitor's booth, nor are GES and its subcontractors responsible for Exhibitor's materials before they are picked up from the Exhibitor's booth for loading after the show. Consequently, all bills of lading covering outgoing shipment(s) submitted to GES or its subcontractors by Exhibitor will be checked at the time of pick-up from the booth and corrected where discrepancies exist.

3. GES and its subcontractors shall not be held liable for any damage incurred during the handling of equipment requiring special devices to properly load, place or reload unless advance notice has been given to GES in time to obtain the proper equipment.

4. GES and its subcontractors shall not be responsible for loss, delay or damage due to strikes, lockouts or work stoppages of any kind.

5. GES and its subcontractors shall not be responsible for ordinary wear and tear in handling of equipment, nor for loss or damage due to fire, theft, windstorm, water, vandalism, acts of God, mysterious disappearance or other causes beyond their control.

6. It is understood that GES and its subcontractors are not insurers. Insurance, if any, shall be obtained by the Exhibitor. Amounts payable to GES hereunder are based on the scope of the liability as herein set forth and are unrelated to the value of the Exhibitor's property. It is further understood and agreed that GES and its subcontractors do not provide for full liability should loss or damage occur. It is agreed that if GES or its subcontractors should be found liable for loss or damage to Exhibitor's equipment, the liability shall be limited to the specific article that was physically lost or damaged. Such liability shall be limited to a sum equal to \$0.30 per pound per article, with a maximum liability of \$50.00 per item or \$1,000.00 per shipment, whichever is less, as agreed upon damages and exclusive remedy. Provisions of this paragraph shall apply if loss or damage, regardless of cause or origin, results directly or indirectly to property through performance services to

Exhibitor's or from negligence, active or otherwise, by GES, its subcontractors or their employees.

7. GES and its subcontractors shall not be liable to any extent whatsoever for any actual, potential or assumed loss of profits or revenues or for any collateral costs that may result from any loss or damage to Exhibitor's materials which may make it impossible or impracticable to exhibit same.

8. Claims for loss or damage must be submitted to GES by the close of the show. No suit or action shall be brought against GES or its subcontractors more than one year after the cause of action.

9. The Exhibitor agrees, in connection with the receipt, handling, temporary storage and reloading of its materials, that GES and its subcontractors will provide these services as Exhibitor's agent and not as bailee or shipper. If any employee of GES or its subcontractors shall sign a delivery receipt, bill of lading or other document, we agree that GES or its subcontractor will do so as the Exhibitor's agent, and the Exhibitor accepts the responsibility thereof.

10. GES and its subcontractors shall not be liable for shipments received without receipts, freight bills or specified unit counts on receipts or freight bills, such as a courier or van lines. Such shipments will be delivered to booth without guarantee of piece count or condition.

11. Empty container labels will be available at the GES Service Centre. Affixing the labels is the sole responsibility of the Exhibitor or its representative. It is understood that these labels are used for EMPTY STORAGE ONLY, and GES and its subcontractors assume no responsibility for loss or damage to contents while containers are in storage or for mislabelled containers.

12. In order to expedite removal of materials from the show site, GES shall have the authority to change designated carriers, if such carriers do not pick up on time. Where no disposition is made by the Exhibitor, materials will be taken to a warehouse to await Exhibitor's shipping instructions, and the Exhibitor agrees to be responsible for payment of charges relating to such handling at the warehouse. GES assumes no liability as a result of such re-routing or handling.

13. The Exhibitor agrees, in the event of a dispute with GES or its subcontractors relative to any loss or damage to any of your materials or equipment, that the Exhibitor will not withhold payment in any amount due to GES for material handling services or any other services provided by GES or its subcontractors as an offset against the amount of the alleged loss or damage. Instead, the Exhibitor agrees to pay GES prior to the close of the show for all such charges and further agrees that any claim the Exhibitor may have against GES or its subcontractors shall be pursued independently by the Exhibitor as a completely separate transaction to be resolved on its own merits.

The consignment or delivery of a shipment to GES or its subcontractors by an Exhibitor or by any shipper on behalf of the Exhibitor shall be construed as an acceptance by such Exhibitor (and/or other shipper) of the terms and conditions set forth in Sections 1 through 13 above.

**Be sure your materials are insured** from the time they leave your firm until they are returned after the show. It is suggested that Exhibitors arrange all risk coverage. This can usually be done by riders to existing policies. Contact your insurance representative. Be sure your liability insurance is in effect during transit and return of your materials, during storage and at show site.

# DIRECT TO SHOW SITE SHIPPING LABEL

Ontario's Water Conference and Trade Show

## EXHIBIT SHIPMENT FOR DIRECT TO SHOWSITE

**SHIPPER:** \_\_\_\_\_  
(Name of Company where shipment originates.)

**TO:** \_\_\_\_\_  
(Name of your exhibiting Company at the show.)

**BOOTH NUMBER:** \_\_\_\_\_  
(Your booth number at the show.)

**C/O:** GES/Ontario's Water Conference and Trade Show  
Scotiabank Convention Centre  
6815 Stanley Ave.  
Niagara Falls, Ontario, Canada  
L2G 3Y9

**CARRIER:** \_\_\_\_\_  
(Name of your Transportation Company)

**NUMBER**  **OF**  **PIECES**

**DIRECT SHIPMENTS TO SHOWSITE TO ARRIVE ON:**

**Sunday May 8, 2017**



# logistics

## GES Logistic Services

*GES is proud  
to offer our  
clients a one  
source solution  
for  
Customs and  
Transportation  
services*

### Your Choice of Reliable Service Options

- Time Critical Ground
- Expedited Ground
- 3-5 Day Deferred
- Common Carrier
- Van Line

### 24-Hour Tracking

Call toll free 1-877-437-4247 for immediate information on the status of your shipment

### On-Site Representation

GES Logistics representatives will be on site from the beginning of move-in and throughout the event until the last shipment leaves the show floor

### Competitive Pricing

You will benefit from priority delivery at competitive prices thanks to special arrangements we have with select carriers

### Simplified Budgeting

Our transportation management system gives you the information you need to budget more effectively

### Simplified Ordering

For your convenience choose one of the ordering options available:

- Online: [www.gesexpo.ca](http://www.gesexpo.ca)
- Phone: 905-283-0500 or 1-877-437-4247
- Fax: 905-283-0501

**Ship everywhere with GES Logistics Services.**



# SHIPPING

5675 McLaughlin Road, Mississauga, Ontario, L5R 3K5 Tel: 905-283-0500 Fax: 905-283-0501 Toll Free: 1-877-437-4247  
torontoexhibitorservices@ges.com www.gesexpo.ca

## PICK UP INFORMATION

COMPANY NAME: \_\_\_\_\_ PICK UP DATE: \_\_\_\_\_ PICK UP TIME: \_\_\_\_\_  
 ADDRESS: \_\_\_\_\_ BUSINESS HOURS: \_\_\_\_\_ LOADING DOCK:  YES  NO  
 CITY: \_\_\_\_\_ PROV/STATE: \_\_\_\_\_ CODE: \_\_\_\_\_ CUSTOMS PAPERWORK ATTACHED:  YES  NO  
 CONTACT: \_\_\_\_\_ IF YES, CUSTOMS BROKER: \_\_\_\_\_  
 PHONE: \_\_\_\_\_ CONTACT: \_\_\_\_\_  
 FAX: \_\_\_\_\_ EMAIL: \_\_\_\_\_ PHONE: \_\_\_\_\_

I will be shipping to:  ADVANCED WAREHOUSE  SHOW SITE

## DESTINATION

COMPANY NAME: \_\_\_\_\_ BOOTH #: \_\_\_\_\_  
 ON-SITE CONTACT: \_\_\_\_\_  
 SHOW NAME: **Ontario's Water Conference and Trade Show** DELIVERY DATE: \_\_\_\_\_ DELIVERY TIME: \_\_\_\_\_  
 FACILITY: **Scotiabank Convention Centre**  
 ADDRESS: **6815 Stanley Ave.**  
 CITY: **Niagara Falls** PROV/STATE: **Ontario** POSTAL CODE: **L2G 3Y9**

## SERVICE REQUIRED

ONE WAY  ROUND TRIP  
 TIME CRITICAL  3-5 DAY  GROUND

## ITEMS TO BE SHIPPED

SERVICE WILL BE CHARGED ON **ACTUAL** WEIGHT & DIMENSIONS

TOTAL NUMBER OF PIECES:	DIMENSIONS IN INCHES:	ESTIMATED WEIGHT:
_____ CARTONS (CARDBOARD)	H _____ x W _____ x L _____	
_____ CASES/TRUNKS (FIBRE) COLOUR: _____	H _____ x W _____ x L _____	
_____ CRATES (WOODEN)	H _____ x W _____ x L _____	
_____ SKIDS/PALLETS	H _____ x W _____ x L _____	
_____ CARPET/COLOUR: _____	H _____ x W _____ x L _____	
_____ OTHER LIST: _____	H _____ x W _____ x L _____	
_____ TOTAL	TOTAL WEIGHT:	

## BILLING AND PAYMENT INFORMATION

COMPANY NAME: \_\_\_\_\_ ADDRESS: \_\_\_\_\_ CITY: \_\_\_\_\_  
 PROV/STATE: \_\_\_\_\_ CODE: \_\_\_\_\_ EMAIL: \_\_\_\_\_ TEL: \_\_\_\_\_  
 CREDIT CARD NUMBER: \_\_\_\_\_ EXPIRY DATE: \_\_\_\_\_  
 VISA  MASTERCARD  AMERICAN EXPRESS  
 CARDHOLDER NAME: \_\_\_\_\_ CARDHOLDER SIGNATURE: \_\_\_\_\_

## TERMS & CONDITIONS

GES assumes no responsibility for shipments left in booth by exhibitor. All materials are subject to final count and correction at time of actual removal from booth. Shipper hereby designates GES as its agent for tendering shipments to carrier. GES reserves the right to reroute any outgoing shipment via an alternate carrier in the event the requested carrier fails to pick up the shipment by established carrier check-in deadline. GES assumes no responsibility for misdirected shipments as a result of old shipping labels which remain on containers. It is the shipper's responsibility to state the national motor freight classification commodity description, otherwise shipment shall be described as exhibition materials.

1) GES shall not be responsible for damage to uncrated materials, materials improperly packed, or concealed damage. 2) GES shall not be responsible for loss, theft, or disappearance of exhibitors material after same has been delivered to exhibitor's booth. 3) GES shall not be responsible for loss, theft, or disappearance of materials before they are picked up from exhibitor's booth for reloading after the show. Bill of Lading covering outgoing shipments, which are furnished by GES to exhibitors, will be checked at time of actual pick-up from booth and corrections made where discrepancies occur. 4) GES shall not be responsible for any loss, damage, or delay due to fire, acts of God, strikes, lockouts or work stoppages of any kind, or to any causes beyond its control. 5) GES's liability shall be limited to the physical loss or damage to the specific article which is lost or damaged, and in any event GES's maximum liability shall be limited to \$0.30 per pound per article with a maximum liability of \$50.00 per item, or \$1,000.00 per shipment, whichever is less. 6) GES shall not be liable to any extent whatsoever for any actual, potential, or assumed losses of profits or revenues, or for any collateral costs, which may result from any loss or damage to an exhibitor's materials which may make it impossible or impractical to exhibit same. 7) The consignment or delivery of a shipment to GES by an exhibitor, or by any shipper to or on behalf of the exhibitor, shall be construed as an acceptance by such exhibitor (and/or other shipper) of the terms and conditions set forth. Exhibitor is responsible to declare all hazardous materials and abide by all federal, state and local laws.

By signing this order form, shipper agrees to be bound by all its terms and conditions.

X \_\_\_\_\_ Date: \_\_\_\_\_

Please Print Name: \_\_\_\_\_





## **customs**

*GES is proud  
to offer our  
clients a one  
source solution  
for  
Customs and  
Transportation  
services*

## **GES Customs Services**

### **Reliable and Efficient Service**

- Experienced and reliable staff you can depend on who specialize in trade show Customs procedures
- Personnel are accessible at all times

### **Value Added Service**

- Save time and money by making fewer calls

### **Personalized Service**

- Telephone, email and fax communication
- Forms and instructions for completion in all Exhibitor Service Kits
- One-on-one Customs consultation to assist all exhibitors with their specific needs

### **On-Site Representation**

GES Customs Services representatives will be on site from the beginning of move-in and throughout the event until the last shipment leaves the trade show floor

### **Simplified Ordering**

For your convenience choose one of the ordering options available:

- Online: [www.gesexpo.ca](http://www.gesexpo.ca)
- Phone: 905-283-0500 or 1-877-437-4247
- Fax: 905-283-0501

**Leave all your shipping, customs clearance and furniture rentals to GES.**



# Customs / Transportation Order Form

EXAMPLE

THE ORIGINAL OF THIS ORDER FORM MUST BE COMPLETED & RETURNED TO ENSURE CUSTOMS CLEARANCE  
PLEASE ACCEPT THIS AS YOUR AUTHORITY TO PROVIDE CUSTOMS CLEARANCE AND/OR TRANSPORTATION SERVICES

WE WISH TO USE GES SERVICES  
FOR (PLEASE CHECK ONE)

Customs Clearance  
And Transportation

Customs Clearance  
Only

Transportation  
Only

## SECTION 1 EXHIBITOR AND SHIPMENT INFORMATION

Exhibitor / Company Name: ABC MACHINE COMPANY Email Address: \_\_\_\_\_

U.S. Tax # or U.S. IRS ID #: 31-2293941

Event Name & Booth #: INTERNATIONAL MACHINERY SHOW Booth #: 1430

Facility Name: MTCC - METRO TORONTO CONVENTION CENTRE - SOUTH BLDG

Shipment Date: MARCH 3, 2001 From (City): NEW YORK Carrier Name: GES LOGISTICS

It Consists of (# Cartons): 6 Weight: 1,500  lbs.  kgs.

Our Rep @ Event: BILL SMITH Staying At (Hotel): RYH - ROYAL YORK Tel: 416-368-2511

PLEASE DO NOT SHIP BY PARCEL COURIER OR MAIL - WE WILL NOT BE RESPONSIBLE FOR TIMELY DELIVERY

## SECTION 2 RETURN SHIPMENT CONSIGNMENT INFORMATION

Company Name: ABC MACHINE COMPANY

Delivery Address: 100 - 5<sup>TH</sup> AVENUE

City: NEW YORK Province/State: NEW YORK Postal / Zip: 10012-1010

Name: JOE BROWN Telephone: 212-286-2140 Fax Number: 212-286-2100

Ship Via:  Common Carrier  Our Company Vehicle  Van Line Service  Air Freight Service

## SECTION 3 CREDIT CARD AUTHORIZATION (NOTE - THIS SECTION MUST BE COMPLETED)

I hereby authorize use of the following credit card for payment of services relative to this order form

### CREDIT CARD INFORMATION MUST BE COMPLETED

Charge To:  VISA  MASTERCARD  AMERICAN EXPRESS

Credit Card Number: 123 456 789 012 Expiry: 09 / 03

Cardholder's Name: BILL SMITH Title: DIRECTOR OF SALES

Cardholder's Signature: BILL SMITH

ORIGINAL SIGNATURE REQUIRED

## SECTION 4 INVOICE / STATEMENT INFORMATION

Company Name: ABC MACHINE COMPANY

Mailing Address: 100 - 5<sup>TH</sup> AVENUE

City: NEW YORK Province/State: NY Postal / Zip: 10012-1010

Attention: BILL SMITH Telephone: 212-286-2140 Fax Number: 212-286-2100

## SECTION 5 ORDER AUTHORIZED BY

This Form Was Completed By: JOE BROWN  
( Please Print Full Name )

Title: DIRECTOR OF MARKETING

Date: APRIL 17, 2001



# Customs / Transportation Order Form

THE ORIGINAL OF THIS ORDER FORM MUST BE COMPLETED & RETURNED TO ENSURE CUSTOMS CLEARANCE  
PLEASE ACCEPT THIS AS YOUR AUTHORITY TO PROVIDE CUSTOMS CLEARANCE AND/OR TRANSPORTATION SERVICES

WE WISH TO USE GES SERVICES FOR (PLEASE CHECK ONE)  Customs Clearance And Transportation  Customs Clearance Only  Transportation Only

## SECTION 1 EXHIBITOR AND SHIPMENT INFORMATION

Exhibitor / Company Name: \_\_\_\_\_ Email Address: \_\_\_\_\_  
U.S. Tax # or U.S. IRS ID #: \_\_\_\_\_  
Event Name & Booth #: \_\_\_\_\_ Booth #: \_\_\_\_\_  
Facility Name: \_\_\_\_\_  
Shipment Date: \_\_\_\_\_ From (City): \_\_\_\_\_ Carrier Name: \_\_\_\_\_  
It Consists of (# Cartons): \_\_\_\_\_ Weight: \_\_\_\_\_  lbs.  kgs.  
Our Rep @ Event: \_\_\_\_\_ Staying At (Hotel): \_\_\_\_\_ Tel: \_\_\_\_\_

PLEASE DO NOT SHIP BY PARCEL COURIER OR MAIL - WE WILL NOT BE RESPONSIBLE FOR TIMELY DELIVERY

## SECTION 2 RETURN SHIPMENT CONSIGNMENT INFORMATION

Company Name: \_\_\_\_\_  
Delivery Address: \_\_\_\_\_  
City: \_\_\_\_\_ Province/State: \_\_\_\_\_ Postal / Zip: \_\_\_\_\_  
Name: \_\_\_\_\_ Telephone: \_\_\_\_\_ Fax Number: \_\_\_\_\_  
Ship Via:  Common Carrier  Our Company Vehicle  Van Line Service  Air Freight Service

## SECTION 3 CREDIT CARD AUTHORIZATION (NOTE - THIS SECTION MUST BE COMPLETED)

I hereby authorize use of the following credit card for payment of services relative to this order form

### CREDIT CARD INFORMATION MUST BE COMPLETED

Charge To:  VISA  MASTERCARD  AMERICAN EXPRESS  
Credit Card Number: \_\_\_\_\_ Expiry: \_\_\_\_\_ / \_\_\_\_\_  
Cardholder's Name: \_\_\_\_\_ Title: \_\_\_\_\_  
Cardholder's Signature: \_\_\_\_\_

ORIGINAL SIGNATURE REQUIRED

## SECTION 4 INVOICE / STATEMENT INFORMATION

Company Name: \_\_\_\_\_  
Mailing Address: \_\_\_\_\_  
City: \_\_\_\_\_ Province/State: \_\_\_\_\_ Postal / Zip: \_\_\_\_\_  
Attention: \_\_\_\_\_ Telephone: \_\_\_\_\_ Fax Number: \_\_\_\_\_  
Email: \_\_\_\_\_

## SECTION 5 ORDER AUTHORIZED BY

This Form Was Completed By: \_\_\_\_\_  
( Please Print Full Name )  
Title: \_\_\_\_\_ Date: \_\_\_\_\_

**CANADA CUSTOMS INVOICE / FACTURE DES DOUANES CANADIENNES**

<p>1 Vendor (Name and Address) / Vendeur (Nom et Adresse)</p> <p>ABC MACHINE COMPANY 100-5<sup>TH</sup> AVENUE NEW YORK, NY 10012-1010</p>	<p>2 Date of Direct Shipment to Canada Date d'expédition directe vers le Canada <b>MARCH 3, 2001</b></p> <p>3 Other References (Include Purchaser's Order No.) Autres références (inclure le no de commande de l'acheteur) 31-2293941 (COMPANY IRS#)</p>
--	--

<p>4 Consignee (Name and Address) / Destinataire (Nom et Adresse)</p> <p>ABC MACHINE COMPANY / BOOTH 210 INTERNATIONAL MACHINERY SHOW C/O METRO TORONTO CONVENTION CENTRE SOUTH BLDG  222 BREMNER BLVD TORONTO, ON M5V 2E6</p>	<p>5 Purchaser's Name and Address (if other than Consignee) Nom et Adresse de l'acheteur (s'il diffère du destinataire) NO SALE INVOLVED</p> <p>6 Country of Transshipment / Pays de transbordement N/A</p> <p>7 Country of Origin of Goods Pays d'origine des marchandises <b>U.S.A.</b></p> <p style="font-size: small;">If shipment includes goods of different origins enter origins against items in 12 Si l'expédition comprend des marchandises d'origines différentes, en préciser la provenance en 12</p>
--	--

<p>VII. 1 Is this a related company transaction? Est-ce que les compagnies sont liées entre elles?</p> <p>YES <input type="checkbox"/> OUI                      NO <input type="checkbox"/> NON</p>	<p>9 Condition of Sales and Terms of Payment (i.e. Sale, Consignment Shipment, Leased Goods, etc.) Conditions de vente et modalités de paiement (p. Ex. Vente, Expédition en consignation, location de marchandises, etc.)</p>
---	--

<p>8 Transportation: Give Mode and Place of Direct Shipment to Canada Transport: Préciser mode et lieu d'expédition directe vers le Canada</p> <p>GES LOGISTICS NEW YORK, NY</p>	<p>10 Currency of Settlement / Devises du paiement USD</p>
--	--

11. No. of Pkgs. / Nbre. de colis	12. Specification of Commodities (Kind of Packages) Marks and Numbers, General Description and Characteristics i.e. Grade Quality / Designation des articles (Nature des colis, marques et numéros, description générale et caractéristiques. P. Ex. Classe, qualité)	13. Quantity (State Unit) / Quantité (Préciser l'unité)	Relacement Value / Valeur de Remplacement	
			14. Unit Price / Prix Unitaire	15. Total
3 PCS	WOODEN CRATES-COMPUTERS (CERTIFICATE OF REGISTRATION ATTACHED)	3	\$1,000.00	\$3,000.00
1 PC	CRATE-COMPUTER MONITOR (CERTIFICATE OF REGISTRATION ATTACHED)	1	\$ 500.00	\$ 500.00
1 PC	CARTON-ADVERTISING LITERATURE	1,000	\$ 0.10	\$ 100.00
1 PC	CARTON-PLASTIC KEY CHAINS / BOOKS	50	\$ 0.50	\$ 25.00

<p>XI.1 Total Number of Pieces / Nombre total de pièces <b>6</b></p>		
<p>18 <input type="checkbox"/> If any fields of 1 to 17 are included on an attached commercial invoice, check this box / Si les renseignements des zones 1 à 17 figurent sur la facture commerciale cocher cette case</p> <p>Commercial Invoice No. / No. De la facture commerciale</p>	<p>16. Total Weight / Poids total 1,500bs. <input checked="" type="checkbox"/>kgs.</p> <p>Net. Weight / Gross Wt./ Brut N/A                      1,500 lbs</p>	<p>17. Invoice Total / Total de la facture</p>

<p>19 Exporter's Name and Address (if other than Vendor) Nom et adresse de l'exportateur (s'il diffère du vendeur)</p>	<p>20 Originator (Name and Address) Expéditeur d'origine (Nom et adresse) ABC MACHINE COMPANY 100-5<sup>TH</sup> AVENUE NEW YORK, NY 10012-1010</p> <p>Contact: BILL SMITH</p> <p>Tel: 212-268-2140                      Fax: 212-268-2511</p>
<p>21 Departmental Ruling (if applicable) Decision ministérielle (s'il y a lieu)</p> <p>N/A</p>	

**CANADA CUSTOMS INVOICE / FACTURE DES DOUANES CANADIENNES**

1 Vendor (Name and Address) / Vendeur (Nom et Adresse)	2 Date of Direct Shipment to Canada Date d'expédition directe vers le Canada	3 Other References (Include Purchaser's Order No.) Autres références (inclure le no de commande de l'acheteur)
	5 Purchaser's Name and Address (if other than Consignee) Nom et Adresse de l'acheteur (s'il diffère du destinataire)	
4 Consignee (Name and Address) / Destinataire (Nom et Adresse)	6 Country of Transshipment / Pays de transbordement	
	7 Country of Origin of Goods Pays d'origine des marchandises	If shipment includes goods of different origins enter origins against items in 12 Si l'expédition comprend des marchandises d'origines différentes, en préciser la provenance en 12

VII. 1 Is this a related company transaction? Est-ce que les compagnies sont liées entre elles?  YES <input type="checkbox"/> OUI NO <input type="checkbox"/> NON	9 Condition of Sales and Terms of Payment (i.e. Sale, Consignment Shipment, Leased Goods, etc.) Conditions de vente et modalités de paiement (p. Ex. Vente, Expédition en consignation, location de marchandises, etc.)

8 Transportation: Give Mode and Place of Direct Shipment to Canada Transport: Préciser mode et lieu d'expédition directe vers le Canada	10 Currency of Settlement / Devises du paiement
--	---

11. No. of Pkgs. Nbre. de colis	12 Specification of Commodities (Kind of Packages) Marks and Numbers, General Description and Characteristics i.e. Grade Quality Designation des articles (Nature des colis, marques et numéros, description générale et caractéristiques. P. Ex. Classe, qualité)	13 Quantity (State Unit) Quantité (Préciser l'unité)	Relacement Value Valeur de Remplacement	
			14 Unit Price Prix Unitaire	15 Total

XI.1 Total Number of Pieces / Nombre total de pièces			
18 <input type="checkbox"/> If any fields of 1 to 17 are included on an attached commercial invoice, check this box / Si les renseignements des zones 1 à 17 figurent sur la facture commerciale cocher cette case  Commercial Invoice No. / No. De la facture commerciale	16. Total Weight / Poids total <input type="checkbox"/> lbs. <input type="checkbox"/> kgs.		17. Invoice Total Total de la facture
	Net. Weight	Gross Wt./ Brut	

19 Exporter's Name and Address (if other than Vendor) Nom et adresse de l'exportateur (s'il diffère du vendeur)	20 Originator (Name and Address) Expéditeur d'origine (Nom et adresse)
21 Departmental Ruling (if applicable) Decision ministérielle (s'il y a lieu)	Contact:  Tel: Fax: