

## DISPLAY RULES & REGULATIONS

- No hanging signs or balloons are permitted.
- All exhibit displays must be ground supported.
- All exhibitors with booths 400 square feet and larger are required to submit (or have their display house submit) a scaled PDF rendering of their booth design to ICSC show management no later than **August 18, 2017**. The renderings must include a front and overhead scale view. The rendering must identify complete dimensions including the height of all display structures. The Exhibit Design Submission Form and renderings can be submitted to Mayuri Khemlani at [mkhemlani@icsc.org](mailto:mkhemlani@icsc.org)
- **At no time can a company's name or logo be overseen by their neighbor's exhibit space.**

### IN-LINE BOOTH

In-Line booths have only one side exposed to an aisle and are generally arranged in a series along a straight line.

#### Dimensions

For purposes of consistency and ease of layout and/or reconfiguration, floor plan design in increments of 10' (3.05m) has become the de facto standard in the United States. In-line booths are usually 10' (3.05m) x 10' (3.05m).

#### Use of Space

Regardless of the number of in-line booths utilized (10' x 20', 10' x 30', etc) display materials should be arranged in such a manner so as not to obstruct sight lines of neighboring exhibitors. The maximum height of 8' is allowed only in the rear half of the booth space, with a 4' height restriction imposed on all materials in the remaining space forward to the aisle.

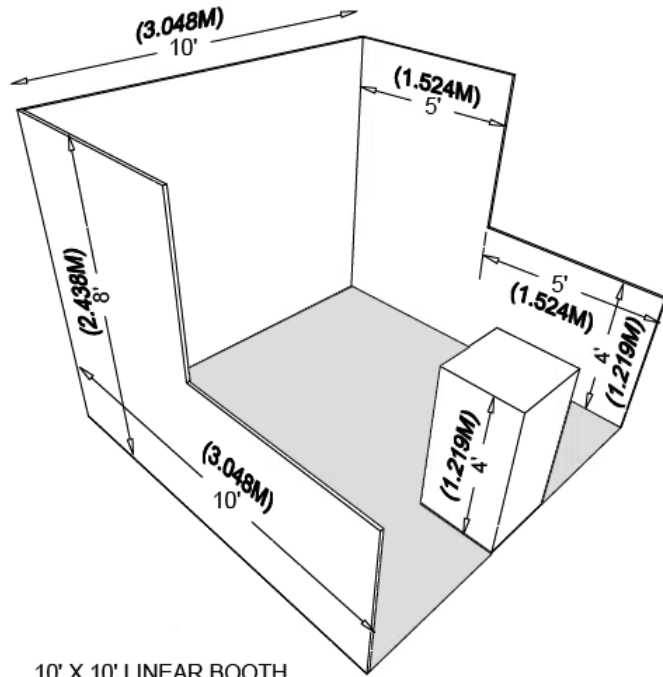

### CORNER BOOTH

A corner booth is an in-line booth exposed to aisles on two sides.

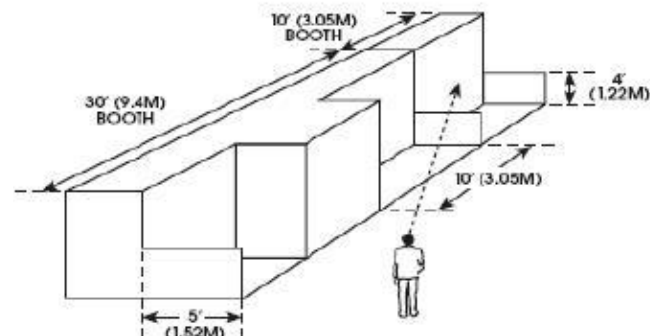

## PERIMETER BOOTH

A Perimeter Booth is an in-line booth that backs to an outside perimeter wall of the exhibit facility rather than to another exhibitor.

### Dimensions/ Use of Space

All guidelines for in-line booths apply to perimeter booths except that the maximum back wall height is 12' (3.66m)

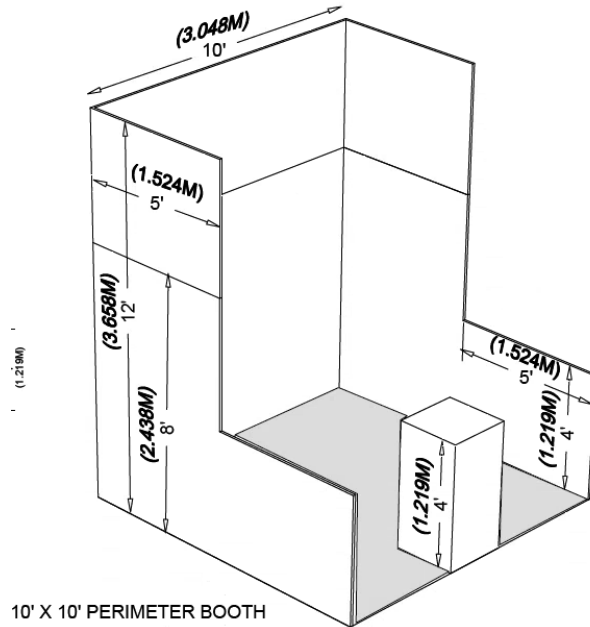

## PENINSULA BOOTH

A Peninsula Booth is exposed to aisles on three sides, and comprised of a minimum of four booths.

### Dimensions

A Peninsula Booth is usually 20ft by 20ft or larger. When a Peninsula Booth backs up to two Linear Booths, the back wall is restricted to 4ft high within 5ft of each aisle, permitting adequate line of sight for the adjoining Linear Booths. Peninsula Booths have a maximum height allowance of Sixteen feet (16'), including signage for the center portion of the back wall. Double-sided signs, logos and graphics shall be set back ten feet (10') from adjacent booths. All back walls must be finished and no graphics are allowed so that the back wall is aesthetically clear to neighboring exhibitors.

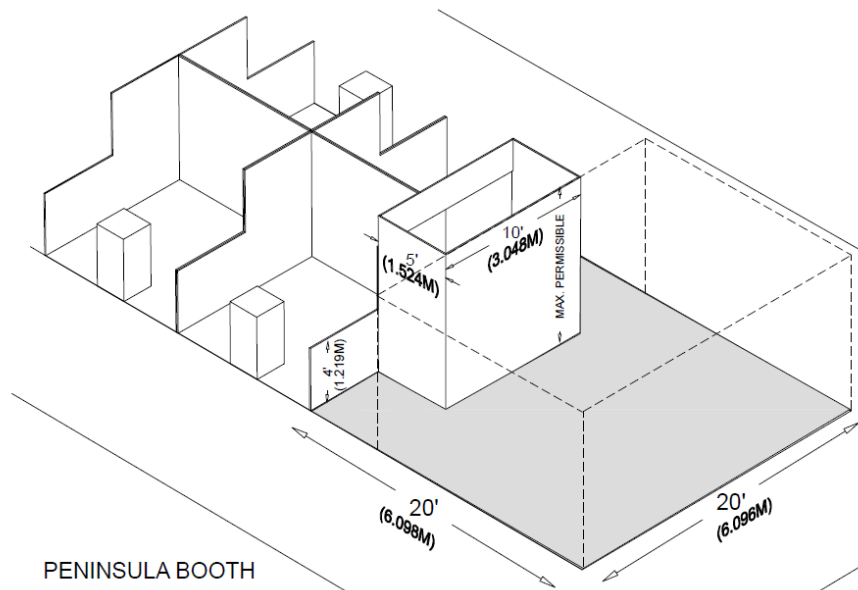

## ISLAND BOOTH

An Island Booth is a 20ft (6.09m) x 20ft (6.09m) or larger sized booth which is not directly adjacent to any other booth and is typically (but not always) exposed to aisles on all four sides.

### Dimensions

Island Booths are a minimum of 20ft (6.09m) x 20ft (6.09m) or larger, although it may be configured differently.

### Use of Space

The entire cubic content of this configuration may be used, up to the maximum allowable height, without any back wall line of sight restrictions. 16ft (4.877m) is the maximum height allowance.

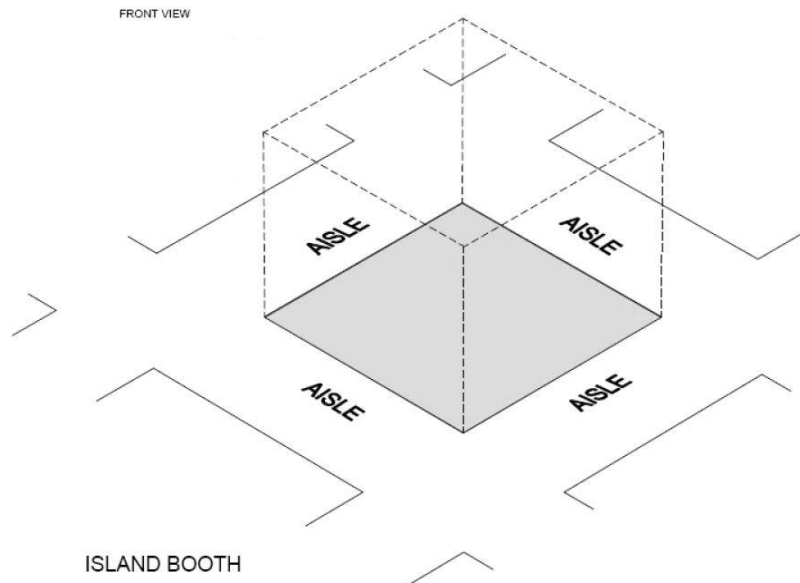

## Raised Flooring in Exhibits:

Low-rise platform flooring is allowable in standard booths, islands, and peninsula islands for covering utility lines (wiring, cabling, piping etc.), for elevating product displays, and for other purposes. All concealed wiring, etc, must be quickly accessible for emergency service.

Raised floors are limited to a maximum height of six (6) inches (15cm). If people will be on them, raised areas must be non-hazardous and wheelchair accessible. Wheelchair ramps must be at least three (3) feet wide (915mm), with a maximum slope of 1:12; a six-inch rise would require a six-foot run. Ramps should be located every 100 feet around the accessible sides of the exhibit. Landings must be provided at tops and bottoms of ramps and must be at least 36 inches (915mm) wide by 60 inches (1525mm) and free of obstructions. Ramps must be curbed or guarded at their edges and surfaces must be firm and slip-resistant (if carpet used, it must be unpaddinged, low pile). Edges of raised floors must be ramped or guarded sufficiently to prevent people from tripping or falling at the transitions.