

IMPORTANT SHOW INFORMATION

We are pleased to announce that GES has been selected as the Official General Services Contractor for your event. Our goal is to help ensure that your show participation is a success.

Please review our payment policy carefully. As a reminder, GES requires payment **in full** at the time you place your order, along with the credit card authorization. This may be used to cover items such as labour and material handling, not included with your initial payment. In addition, any unpaid charges at the end of the event will be charged to the supplied credit card as per GES terms and conditions.

Take advantage of our substantial price discounts! Just return your order with payment by the advance price deadline(s) on the order forms and use the lower price. For ease of ordering, visit gesexpo.ca.

For your convenience, we will be offering the following services:

- | | | |
|---------------------|------------------------------|-----------------------------------|
| - FURNISHINGS | - SPECIALITY FURNISHINGS | - CARPET & UNDERPADDING |
| - GEM SHOW SPECIALS | - GEM EXHIBITS & ACCESSORIES | - PLANTS |
| - BOOTH CLEANING | - SIGNS & GRAPHICS | - INSTALLATION & DISMANTLE LABOUR |
| - IN-BOOTH FORKLIFT | - MATERIAL HANDLING | - GES LOGISTICS & CUSTOMS |

PLEASE NOTE THE FOLLOWING INFORMATION REGARDING YOUR EVENT

SHOW NAME Uni-Select Super Show	SHOW DATES March 4, 2014	LOCATION River Cree Resort
YOUR EXHIBIT BOOTH INCLUDES THE FOLLOWING ITEMS		BOOTH SIZE: 10' x 10'
8' High Drape 3' High Drape 1 - 6' Skirted Table	2 Folding Chairs 1500 Watt Outlet	

KEY SHOW DATES & TIMES

DISCOUNT PRICE DEADLINE DATE:	February 14, 2014	TAKE ADVANTAGE OF 40% SAVINGS	
ADVANCE WAREHOUSE OPEN TO RECEIVE SHIPMENTS:	February 4, 2014	ADVANCE SHIPMENTS MAY START BEING RECEIVED AT THE ADVANCE	
ADVANCE WAREHOUSE CLOSES TO SHIPMENTS:	February 27, 2014	ALL SHIPMENTS AFTER THIS DATE NEED TO BE DIRECT TO SHOWSITE.	
DIRECT TO SHOW SITE SHIPMENT:	March 3, 2014	FIRST DAY DIRECT TO SHOWSITE SHIPMENTS WILL BE RECEIVED.	
FIRST DAY OF GENERAL EXHIBITOR MOVE-IN:	March 3, 2014	FROM	8:00 - 17:00
LAST DAY OF GENERAL EXHIBITOR MOVE-IN:		FROM	
SHOW HOURS	March 4, 2014	8:00 - 17:00	
GENERAL EXHIBITOR MOVE OUT:	March 5, 2014	FROM	8:00 - 17:00
EXHIBITOR MOVE OUT ENDS / FORCED FREIGHT:	March 5, 2014	AT	17:00

Please call or email our team at the numbers listed below with any questions or concerns. Our team is ready and willing to assist you with all your show services related needs.

Phone: 780.469.7767 Fax: 780.469.1619 Toll Free: 877.505.7767 edmonton@ges.com



Accelerate your experience with Expresso exhibit planning, ordering and management.

Exhibitors can order everything they need for their tradeshow exhibit through Expresso, our simple to navigate, picture-driven system that satisfies your need for speed. With just a few clicks exhibitors can order GES products and services including:

- Booth furniture.
- Carpet and flooring.
- Material handling.
- Booth labour.
- And much more.

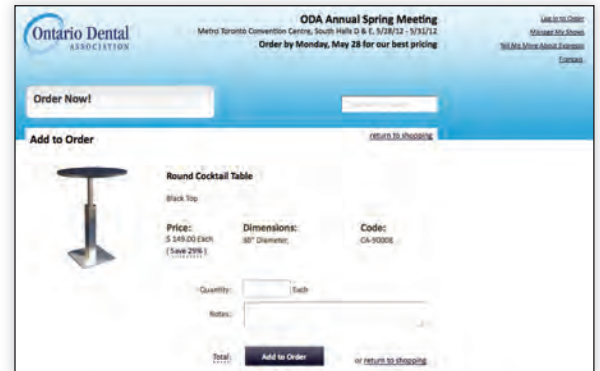

Expresso is more than just an online exhibitor manual. Exhibitors can:

- Order exhibit products and services.
- Print shipping labels.
- View important show and event information.
- Download the show schedule into Outlook or iCalendar.
- View account order status and history.



Experience a difference with Expresso.

- Each show has their own custom website.
- Runs on all browsers for PCs, Macs and tablets.
- Everything in one place; all organizer and show information, ordering and even third party forms.
- Keeps you on-time and on-budget.



SHOW NAME:	Uni-Select Super Show	DISCOUNT PRICE	February 14, 2014
SHOW DATE:	March 4, 2014	DEADLINE DATE:	

TO:	GES Edmonton
FAX:	780-469-1619
EMAIL:	edmonton@ges.com
DATE:	_____
FROM:	_____
COMPANY:	_____
PHONE:	_____
EMAIL:	_____
SHOW NAME:	_____
BOOTH #:	_____



To help us ensure we have received your entire order and we have the correct totals, check off those forms you are sending us and complete value section for each form

	GES ORDER FORM (s)	Pg. Total
<input type="checkbox"/>	Credit Card Authorization	\$
<input type="checkbox"/>	Third Party Billing	\$
<input type="checkbox"/>	Furnishings	\$
<input type="checkbox"/>	Speciality Furnishings	\$
<input type="checkbox"/>	Carpet & Underpad	\$
<input type="checkbox"/>	GEM Exhibit Rentals	\$
<input type="checkbox"/>	GEM Exhibit Accessories	\$
<input type="checkbox"/>	Graphics	\$
<input type="checkbox"/>	Plants	\$
<input type="checkbox"/>	Installation & Dismantle Services	\$
<input type="checkbox"/>	Booth Cleaning	\$
<input type="checkbox"/>	Material Handling	\$
<input type="checkbox"/>	GES Logistics / GES Customs	\$
<input type="checkbox"/>	Electrical	\$

Please call to confirm receipt of your order.

To receive Discount Pricing send your order in by the Discount Price Deadline Date noted above.



THANK YOU FROM GES

SHOW NAME: Uni-Select Super Show
SHOW DATE: March 4, 2014**DISCOUNT PRICE
DEADLINE DATE:**

February 14, 2014

Discount Pricing:

To qualify for **Discount Pricing**, orders must be received **with payment in full on or before the deadline date**. Late orders will be charged the **Regular Price**. Orders without payment cannot be processed until payment is received and may be charged the **Regular Price**.

Method of Payment:

GES accepts American Express, MasterCard, Visa, Cheque and Bank Wire Transfers. Purchase Orders are not considered payment. **Exhibitors will be charged a \$25.00 fee for returned NSF cheques.**

Bank Wire Transfer Information:

To properly credit your account, please complete the **BANK WIRE TRANSFER FORM**, available upon request, and send the following information to the GES Exposition Services (Canada) Limited address listed on the Bank Wire Transfer Form.

NOTE: There is a minimum \$20.00 Service Charge (North America) & \$40.00 (International) applicable on all wire transfers. Fees vary depending on banks processing wire transfers. Also, wire transfers can take 3 to 10 business days to be cleared. Ensure you leave enough time to receive the benefit of the discount. Orders are not processed until payment is received, this includes wire transfers.

PAYMENT SCHEDULE:

Payment for all services must be pre-paid in full. GES will not provide Material Handling, In-Booth Forklifts, or Installation and Dismantle Labour Services without a company's **CREDIT CARD AUTHORIZATION FORM** on file.

THIRD PARTY BILLING:

Arrangements can be made for an exhibit house or other agent to manage exhibit & order services. GES will agree to this arrangement if the exhibit house or agent makes satisfactory payment arrangements prior to start of move-in. In the event the authorized Third Party does not pay, the exhibiting company is ultimately responsible for all charges incurred on its behalf. See **THIRD PARTY BILLING REQUEST FORM**.

ADJUSTMENTS AND CANCELLATIONS:

Adjustments to invoice(s) **will not be made after the close of the show**. Some items, services and labour are subject to cancellation fees. Refer to each order form for details.

EXHIBITORS MUST PAY APPLICABLE TAXES ON ALL ORDERS.

EXHIBITORS ARE RESPONSIBLE FOR ANY UNPAID ORDERS. ALL ORDERS MUST BE PAID IN FULL PRIOR TO RELEASE OF GOODS FROM THE SHOW FLOOR



7730 - 34 Street NW, Edmonton, AB T6B 3J6 Phone: 780.469.7767 Fax: 780.469.1619 Toll Free: 877.505.7767 edmonton@ges.com

CREDIT CARD AUTHORIZATION FORM

SHOW NAME: **Uni-Select Super Show**
SHOW DATE: **March 4, 2014**

DISCOUNT PRICE
DEADLINE DATE: **Friday, February 14, 2014**

EXHIBITOR INFORMATION

IMPORTANT - READ CAREFULLY

BOOTH #: _____

COMPANY: _____

STREET: _____

CITY: _____ PROV/STATE: _____ CODE: _____

EMAIL: _____

PHONE: _____ FAX: _____

CONTACT NAME: _____

PLEASE FILL OUT THE CREDIT CARD AUTHORIZATION BELOW IF:

- Paying by Credit Card for any service.
- Payment is being forwarded to GES in the form of a cheque.
- There is any possibility that additional service(s) will be ordered on-site.
- Material Handling, Installation and Dismantle Labour or In-Booth Forklift Services will be required.

PLEASE COMPLETE THE FOLLOWING

VISA AMERICAN EXPRESS MASTERCARD EXPIRY DATE:

TYPE OF CARD PERSONAL CORPORATE

CARD #

CARDHOLDER'S NAME (PRINT): _____

CARDHOLDER'S SIGNATURE: _____

CARDHOLDER'S BILLING ADDRESS: _____

CITY: _____ PROV/STATE: _____ CODE/ZIP: _____

TELEPHONE: _____ FAX: _____

This authorization allows GES to charge any fees outstanding after show closing to this credit card.
(including funds owed due to a cheque returned NSF)

CHEQUES WILL NOT BE ACCEPTED WITHOUT THIS CREDIT CARD AUTHORIZATION

IF THIS AUTHORIZATION IS NOT COMPLETED, ALL ON-SITE ORDERS ARE EXPECTED TO BE PAID IN FULL BEFORE DELIVERY

PLEASE SEE NOTE REGARDING GES TERMS AND CONDITIONS BELOW

All equipment rental orders placed with GES are bound by the terms and conditions specific to each rental order form, material handling terms and conditions and GES standard terms and conditions located at the back of this kit. By signing below, you agree to all these terms and conditions. Without an authorized signature and date below, your order will not be processed.

I HAVE READ AND UNDERSTAND THE TERMS & CONDITIONS OF MY AGREEMENT WITH GES.

Signature

Print Name & Title

Date

THIRD PARTY BILLING AUTHORIZATION FORM

SHOW NAME:	Uni-Select Super Show	DISCOUNT PRICE DEADLINE DATE:	Friday, February 14, 2014
SHOW DATE:	March 4, 2014	IMPORTANT - READ CAREFULLY	

EXHIBITOR INFORMATION

BOOTH #: _____

COMPANY: _____

STREET: _____

CITY: _____ PROV/STATE: _____ CODE: _____

EMAIL: _____

PHONE: _____ FAX: _____

CONTACT NAME: _____

An exhibit house or other third party agent may handle display and booth arrangements and be charged for services. GES will agree to this arrangement if the exhibit house or agent makes satisfactory arrangements.

Both firms must complete this form and return to GES by the Discount Price Deadline Date. It is understood and agreed that the exhibitor (exhibiting company) is ultimately responsible for payment of charges. If the named third party has NOT paid any outstanding invoices before the last day of the show, any and all outstanding balances will be charged to the exhibiting company's credit card.

Exhibiting Company

Name of Exhibiting Company	Phone#	Fax #	
Address	City	Prov / State	Code / Zip
Authorized Name (Print)	Authorized Signature		

CREDIT CARD AUTHORIZATION

<input type="checkbox"/> VISA	<input type="checkbox"/> AMERICAN EXPRESS	<input type="checkbox"/> MASTERCARD	EXPIRY DATE: <input style="width: 80px;" type="text"/>
TYPE OF CARD	<input type="checkbox"/> PERSONAL	<input type="checkbox"/> CORPORATE	
CARD #	<input style="width: 25px;" type="text"/> <input style="width: 25px;" type="text"/> <input style="width: 25px;" type="text"/> <input style="width: 25px;" type="text"/>	<input style="width: 25px;" type="text"/> <input style="width: 25px;" type="text"/> <input style="width: 25px;" type="text"/> <input style="width: 25px;" type="text"/>	<input style="width: 25px;" type="text"/> <input style="width: 25px;" type="text"/> <input style="width: 25px;" type="text"/> <input style="width: 25px;" type="text"/>
CARDHOLDER'S NAME (PRINT): _____			
CARDHOLDER'S SIGNATURE: _____			

Third Party / Exhibit House

Name of Third Party / Exhibit House	Phone#	Fax #	
Address	City	Prov / State	Code / Zip
Authorized Name (Print)	Authorized Signature		

CREDIT CARD AUTHORIZATION

<input type="checkbox"/> VISA	<input type="checkbox"/> AMERICAN EXPRESS	<input type="checkbox"/> MASTERCARD	EXPIRY DATE: <input style="width: 80px;" type="text"/>
TYPE OF CARD	<input type="checkbox"/> PERSONAL	<input type="checkbox"/> CORPORATE	
CARD #	<input style="width: 25px;" type="text"/> <input style="width: 25px;" type="text"/> <input style="width: 25px;" type="text"/> <input style="width: 25px;" type="text"/>	<input style="width: 25px;" type="text"/> <input style="width: 25px;" type="text"/> <input style="width: 25px;" type="text"/> <input style="width: 25px;" type="text"/>	<input style="width: 25px;" type="text"/> <input style="width: 25px;" type="text"/> <input style="width: 25px;" type="text"/> <input style="width: 25px;" type="text"/>
CARDHOLDER'S NAME (PRINT): _____			
CARDHOLDER'S SIGNATURE: _____			

ALL GES SERVICES ARE TO BE CHARGED TO THE THIRD PARTY / EXHIBIT HOUSE EXCEPT FOR THE FOLLOWING:

PLEASE SEE NOTE REGARDING GES TERMS AND CONDITIONS BELOW

All equipment rental orders placed with GES are bound by the terms and conditions specific to each rental order form, material handling terms and conditions and GES standard terms and conditions located at the back of this kit. By signing below, you agree to all these terms and conditions. Without an authorized signature and date below, your order will not be processed.

I HAVE READ AND UNDERSTAND THE TERMS & CONDITIONS OF MY AGREEMENT WITH GES.

Signature	Print Name & Title	Date
-----------	--------------------	------

SHOW NAME:	Uni-Select Super Show	DISCOUNT PRICE	
SHOW DATE:	41702	DEADLINE DATE	Friday, February 14, 2014

Please return confirmation by fax that this wire transfer has been sent to:

Magda Roithmeier
Accounts Receivable
GES
Phone: 905-283-0574 or
Fax: 905-283-0501 or
Email: ar@ges.com

Your Company Name: _____

Contact Name: _____

Contact Number: _____

Booth Number: _____ Event Name: _____

GES BANK INFORMATION

If you are sending Canadian Dollars

PLEASE INCLUDE ALL THE FOLLOWING INFORMATION TO ENSURE YOUR FUNDS REACH OUR BANK

Account Name: GES Exposition Services (Canada) Limited

Bank Name: Canadian Imperial Bank of Commerce

Address: 939 Lawrence Avenue E.
North York, Ontario Canada
M2C 1P9

Swift Code: CIBCCATT **Account #:** 73-07616

Beneficiary's Bank: //CC001000132

Routing / BIC / NCC/ BSC or ABA Number: 026009593

Invoice Amount: _____ **Date of Transfer:** _____

Min. Bank Charge: \$20.00 (North American / \$40.00 (International))

Total: _____

If you are sending American Dollars

PLEASE INCLUDE ALL THE FOLLOWING INFORMATION TO ENSURE YOUR FUNDS REACH OUR BANK

Account Name: GES Exposition Services (Canada) Limited

Bank Name: Canadian Imperial Bank of Commerce

Address: 939 Lawrence Avenue E.
North York, Ontario Canada
M2C 1P9

Swift Code: CIBCCATT **Account #:** 0267015

Beneficiary's Bank: //CC001000132

Routing / BIC / NCC/ BSC or ABA Number: 026009593

Invoice Amount: _____ **Date of Transfer:** _____

Min. Bank Charge: \$20.00 (North American / \$40.00 (International))

Total: _____

Please Note: Ensure transfer is made a minimum of 10 days prior to the show move in date.
*Minimum Bank Charges as shown above, reflect GES's bank charges only.
Any additional Wire Transfer and EFT fees are the exhibitors responsibility.

**COMPLIMENTARY TABLE
SIZE REQUEST**

SHOW NAME:	Uni-Select Super Show	DEADLINE DATE:	Friday, February 14, 2014
SHOW DATE:	March 4, 2014		

EXHIBITOR INFORMATION	CREDIT CARD AUTHORIZATION
BOOTH #: _____ COMPANY: _____ STREET: _____ CITY: _____ PROV/STATE: _____ CODE: _____ EMAIL: _____ PHONE: _____ FAX: _____ CONTACT NAME: _____	<p>Please be advised that each exhibit booth will be supplied with one (1) skirted table. If you require a specific size table (8', 6', or 4'), please complete this form and forward it to our office prior to the "Deadline Date" above.</p>

Any on-site changes to the supplied tables will be charged at \$25.00 per change. Please choose a table size and fill out the contact information at the top of the form.

Please Note: Tables are skirted on three (3) sides only. If you wish to have the fourth side skirted please order additional skirting on our Furniture & Accessories Order Form.

√	<input type="checkbox"/>	4' Skirted Table
√	<input type="checkbox"/>	6' Skirted table
√	<input type="checkbox"/>	8' Skirted Table

TERMS AND CONDITIONS

- ALL ORDERS RECEIVED AFTER DISCOUNT PRICE DATE WILL BE PROCESSED AT THE REGULAR PRICE.
- EXHIBITOR IS RESPONSIBLE FOR ALL ITEMS FOR THE DURATION OF THE SHOW.
- IF A COLOUR IS NOT CHOSEN, GES WILL CHOOSE A COLOUR FOR YOU.
- CHARGES ARE FOR RENTAL OF EQUIPMENT ONLY. ALL ITEMS REMAIN THE PROPERTY OF GES.
- GES IS NOT RESPONSIBLE FOR EXHIBIT MATERIALS LEFT IN GEM RENTAL EXHIBITS OR COUNTER STORAGE UNITS.
- ALL CLAIMS OR DISCREPANCIES MUST BE SETTLED AT THE GES SERVICE CENTRE PRIOR TO SHOW CLOSING.
- NO REFUNDS/EXCHANGES ON CANCELLED SKIRTED TABLES OR CUSTOM BOOTH DRAPING ONCE DELIVERED.
- 50% REFUND ON FURNISHINGS CANCELLED PRIOR TO SHOW OPENING EXCEPT AS NOTED ABOVE.

I HAVE READ AND UNDERSTAND THE TERMS & CONDITIONS OF MY AGREEMENT WITH GES.

SIGNATURE

DATE

FURNISHINGS ORDER FORM

SHOW NAME: **Uni-Select Super Show**
 SHOW DATE: **March 4, 2014**

DISCOUNT PRICE DEADLINE DATE: **Friday, February 14, 2014**

EXHIBITOR INFORMATION

CREDIT CARD AUTHORIZATION

BOOTH #: _____

COMPANY: _____

STREET: _____

CITY: _____ PROV/STATE: _____ CODE: _____

EMAIL: _____

PHONE: _____ FAX: _____

CONTACT NAME: _____

NO ORDER WILL BE CONSIDERED FINAL UNTIL CREDIT CARD AUTHORIZATION FORM IS COMPLETED AND SUBMITTED WITH THIS FORM.

ALL ORDERS MUST BE PREPAID IN FULL (ORDERS CANNOT BE PROCESSED UNTIL PAYMENT IS RECEIVED)

FURNISHINGS

QTY	DESCRIPTION	DISCOUNT PRICE	REGULAR PRICE	TOTAL
	GREY FABRIC SIDE CHAIR	\$35.00	\$49.00	
	GREY FABRIC COUNTER STOOL	\$77.00	\$108.00	
	GREY FABRIC ARM CHAIR	\$36.00	\$50.00	
	PLASTIC FOLDING CHAIR	\$23.00	\$32.00	
	COFFEE TABLE 18" HIGH ROUND	\$51.00	\$71.00	
	STARBASE TABLE 30" ROUND 30" HIGH	\$67.00	\$94.00	
	COCKTAIL TABLE 30" ROUND 40" HIGH	\$81.00	\$113.00	
	22" X 28" CHROME SIGN HOLDER	\$43.50	\$61.00	
	EASEL	\$36.50	\$51.00	
	SMALL GOLD BALLOT DRUM	\$67.00	\$94.00	
	BAG HOLDER 40" HIGH	\$61.00	\$85.00	
	TAPE STANCHION (7')	\$38.50	\$54.00	
	GARMENT RACK ON WHEELS	\$41.00	\$57.00	
	WASTEBASKET	\$20.00	\$28.00	
	BASEPLATE & 8 FT H POLE	\$18.50	\$26.00	
	6FT - 10 FT CROSSBAR	\$14.00	\$20.00	
	REFRIGERATOR	\$190.00	\$266.00	

SKIRTED TABLES 30" HIGH

BLACK BLUE SILVER WHITE RED GREEN BURGUNDY

QTY	DESCRIPTION	DISCOUNT PRICE	REGULAR PRICE	TOTAL
	4 FT LONG X 2 FT WIDE	\$77.00	\$108.00	
	6 FT LONG X 2 FT WIDE	\$84.00	\$118.00	
	8 FT LONG X 2 FT WIDE	\$91.00	\$127.00	
	SKIRTED FOURTH SIDE	\$33.00	\$46.00	

SKIRTED COUNTER 42" HIGH

BLACK BLUE SILVER WHITE

QTY	DESCRIPTION	DISCOUNT PRICE	REGULAR PRICE	TOTAL
	4 FT LONG X 2 FT WIDE	\$87.00	\$122.00	
	6 FT LONG X 2 FT WIDE	\$108.00	\$151.00	
	8 FT LONG X 2 FT WIDE	\$132.00	\$185.00	
	SKIRTED FOURTH SIDE	\$33.00	\$46.00	

NON SKIRTED 30" HIGH TABLES (VINYL ONLY)

4FT 6FT 8FT \$61.00 \$85.00

QTY	DESCRIPTION	DISCOUNT PRICE	REGULAR PRICE	TOTAL
	4FT	\$98.00	\$137.00	

NON SKIRTED 42" HIGH TABLES (VINYL ONLY)

4FT 6FT 8FT \$98.00 \$137.00

CUSTOM BOOTH DRAPING

BLACK BLUE WHITE RED GREEN

QTY	DESCRIPTION	DISCOUNT PRICE	REGULAR PRICE	TOTAL
	3' HIGH (PER LINEAR FOOT)	\$6.50	\$9.00	
	8' HIGH (PER LINEAR FOOT)	\$7.00	\$10.00	

TERMS AND CONDITIONS

- ALL ORDERS RECEIVED AFTER DISCOUNT PRICE DATE WILL BE PROCESSED AT THE REGULAR PRICE.
- EXHIBITOR IS RESPONSIBLE FOR ALL ITEMS FOR THE DURATION OF THE SHOW.
- IF A COLOUR IS NOT CHOSEN, GES WILL CHOOSE A COLOUR FOR YOU.
- CHARGES ARE FOR RENTAL OF EQUIPMENT ONLY. ALL ITEMS REMAIN THE PROPERTY OF GES.
- GES IS NOT RESPONSIBLE FOR EXHIBIT MATERIALS LEFT IN GEM RENTAL EXHIBITS OR COUNTER STORAGE UNITS.
- ALL CLAIMS OR DISCREPANCIES MUST BE SETTLED AT THE GES SERVICE CENTRE PRIOR TO SHOW CLOSING.
- NO REFUNDS/EXCHANGES ON CANCELLED SKIRTED TABLES OR CUSTOM BOOTH DRAPING ONCE DELIVERED.
- 50% REFUND ON FURNISHINGS CANCELLED PRIOR TO SHOW OPENING EXCEPT AS NOTED ABOVE.

I HAVE READ AND UNDERSTAND THE TERMS & CONDITIONS OF MY AGREEMENT WITH GES.

SUBTOTAL	
GST 5%	
TOTAL	
INCLUDE TOTAL FROM THIS PAGE ON ORDER CHECKLIST SHEET	

SIGNATURE

DATE

furnishings



Grey Fabric Side Chair



Grey Fabric Counter Stool



Grey Fabric Arm Chair



Grey Lounge Chair



Steno Chair



30" Round / 30" High Pedestal Table



30" Round / 18" High Coffee Table



4', 6', OR 8' Long Raised Draped Table with White Vinyl Top



4', 6', OR 8' Long Draped Table with White Vinyl Top



furnishings



Coat Tree



22" X 28"
Chrome Sign Holder
(sign extra)



Easel



Gold Ballot Drum



Plexi Pocket



40" w x 20" d x 36" h
White Counter Storage Unit



Bag Holder 41"H



Stanchions



Plastic
Wastebasket



SPECIALITY FURNISHINGS ORDER FORM

SHOW NAME: Uni-Select Super Show
SHOW DATE: March 4, 2014

DISCOUNT PRICE DEADLINE DATE: Friday, February 14, 2014

EXHIBITOR INFORMATION

CREDIT CARD AUTHORIZATION

BOOTH #: _____

COMPANY: _____

STREET: _____

CITY: _____ PROV/STATE: _____ CODE: _____

EMAIL: _____

PHONE: _____ FAX: _____

CONTACT NAME: _____

**NO ORDER WILL BE CONSIDERED
FINAL UNTIL CREDIT CARD
AUTHORIZATION FORM IS COMPLETED
AND SUBMITTED WITH THIS FORM**

**ALL ORDERS MUST BE PREPAID IN FULL
(ORDERS CANNOT BE PROCESSED UNTIL PAYMENT IS RECEIVED)**

QTY	ITEM #	DESCRIPTION	DISCOUNT PRICE	REGULAR PRICE	Total
	41A (EFBS)	FANBACK STOOL	\$115.00	\$161.00	
	41B (FPEDT)	COCKTAIL TABLE 30" ROUND 40" HIGH	\$81.00	\$113.00	
	42A (EBLBS)	LEATHER BISTRO STOOL	\$135.00	\$189.00	
	43A (EGFBS)	FABRIC BISTRO STOOL	\$148.00	\$207.00	
	44A (EBLMC)	LEATHER MEETING CHAIR	\$92.00	\$129.00	
	44B (EBMT)	42" MEETING TABLE	\$135.00	\$189.00	
	45A (EGFC)	LEATHER HIGH BACK MEETING CHAIR	\$99.00	\$139.00	
	(EBLHC)	LEATHER HIGH BACK ROLLING CHAIR	\$131.00	\$183.00	
	(EBLS3)	LEATHER SOFA - 3 SEATER	\$225.00	\$315.00	
	(EBLS2)	LEATHER SOFA - 2 SEATER	\$187.00	\$262.00	
	(EBLS1)	LEATHER SOFA CHAIR - 1 SEAT	\$147.00	\$206.00	
	(ECTC3)	COFFEE TABLE	\$65.00	\$91.00	
	(EETC3)	END TABLES	\$45.00	\$63.00	
	(FLR)	LITERATURE RACK	\$89.00	\$125.00	

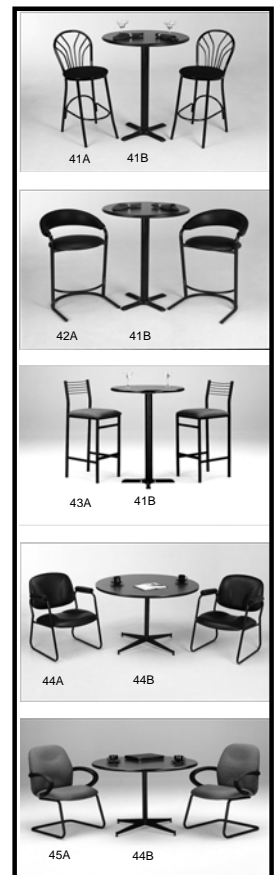

TERMS AND CONDITIONS

- ALL ORDERS RECEIVED AFTER DISCOUNT PRICE DATE WILL BE PROCESSED AT THE REGULAR PRICE.
- EXHIBITOR IS RESPONSIBLE FOR ALL ITEMS FOR THE DURATION OF THE SHOW.
- IF A COLOUR IS NOT CHOSEN, GES WILL CHOOSE A COLOUR FOR YOU.
- CHARGES ARE FOR RENTAL OF EQUIPMENT ONLY. ALL ITEMS REMAIN THE PROPERTY OF GES.
- GES IS NOT RESPONSIBLE FOR EXHIBIT MATERIALS LEFT IN GEM RENTAL EXHIBITS OR COUNTER STORAGE UNITS.
- ALL CLAIMS OR DISCREPANCIES MUST BE SETTLED AT THE GES SERVICE CENTRE PRIOR TO SHOW CLOSING.
- NO REFUNDS/EXCHANGES ON CANCELLED SKIRTED TABLES OR CUSOM BOOTH DRAPING ONCE DELIVERED.
- 50% REFUND ON FURNISHINGS CANCELLED PRIOR TO SHOW OPENING EXCEPT AS NOTED ABOVE.

I HAVE READ AND UNDERSTAND THE TERMS & CONDITIONS OF MY AGREEMENT WITH GES.

SUBTOTAL	
GST 5%	
TOTAL	
INCLUDE TOTAL FROM THIS PAGE ON ORDER CHECKLIST SHEET	

SIGNATURE

DATE

CARPET ORDER FORM

SHOW NAME:	Uni-Select Super Show	DISCOUNT PRICE DEADLINE DATE:	Friday, February 14, 2014
SHOW DATE:	March 4, 2014	CREDIT CARD AUTHORIZATION	

EXHIBITOR INFORMATION BOOTH #: _____ COMPANY: _____ STREET: _____ CITY: _____ PROV/STATE: _____ CODE: _____ EMAIL: _____ PHONE: _____ FAX: _____ CONTACT NAME: _____	NO ORDER WILL BE CONSIDERED FINAL UNTIL CREDIT CARD AUTHORIZATION FORM IS COMPLETED AND SUBMITTED WITH THIS FORM.
--------------------------------------------------------------------------------------------------------------------------------------------------------------------------------------------------	--------------------------------------------------------------------------------------------------------------------------

**ALL ORDERS MUST BE PREPAID IN FULL
(ORDERS CANNOT BE PROCESSED UNTIL PAYMENT IS RECEIVED)**

BOOTH CARPET - STANDARD SIZE
NOTE: EXHIBITORS ORDERING MULTIPLE PIECES OF CARPET IN THIS SECTION MAY NOT RECEIVE THE SAME DYELOT

QTY.	DESCRIPTION	DISCOUNT PRICE	REGULAR PRICE	TOTAL
	10 X 10 INLINE	\$145.00	\$203.00	
	10 X 20 INLINE	\$290.00	\$406.00	
	10 X 30 INLINE (STRAIGHT LINE)	\$435.00	\$609.00	

COLOUR SELECTION: BLACK BLUE GREY RED GREEN

BOOTH CARPET - CUSTOM SIZE
IF YOUR BOOTH REQUIRES A SIZE NOT LISTED ABOVE, PLEASE COMPLETE THIS SECTION.

BOOTH SIZE: _____ FT. X _____ FT. = _____ SQ. FT.	\$1.45	\$2.03	
---------------------------------------------------	--------	--------	--

COLOUR SELECTION: BLACK BLUE GREY RED GREEN

UNDERPADDING - PRICE PER SQUARE FOOT INSTALLED (100 SQ. FT. MIN.)

BOOTH SIZE: _____ FT. X _____ FT. = _____ SQ. FT.	\$0.97	\$1.36	
---------------------------------------------------	--------	--------	--

PROTECTIVE PLASTIC COVERING - PRICE PER SQ. FT. INSTALLED (STANDARD SIZES ONLY) - PRICING IS FOR INSTALLATION ONLY. EXHIBITOR IS RESPONSIBLE FOR REMOVAL.

BOOTH SIZE: _____ FT. X _____ FT. = _____ SQ. FT.	\$0.21	\$0.29	
---------------------------------------------------	--------	--------	--

PLEASE SELECT ONE FOR STANDARD OR CUSTOM SIZE CARPETS
 IF ORDERING ELECTRICAL OR TELECOMMUNICATIONS SERVICES, WILL UNDER CARPET WIRING BE REQUIRED?
 YES NO

TERMS AND CONDITIONS

- ALL ORDERS RECEIVED AFTER DISCOUNT PRICE DATE WILL BE PROCESSED AT THE REGULAR PRICE.
- EXHIBITOR IS RESPONSIBLE FOR ALL ITEMS FOR THE DURATION OF THE SHOW.
- NO REFUNDS/EXCHANGES ON CARPETS ONCE DELIVERED.
- CHARGES ARE FOR RENTAL OF EQUIPMENT ONLY. ALL ITEMS REMAIN THE PROPERTY OF GES.
- ALL CLAIMS OR DISCREPANCIES MUST BE SETTLED AT THE GES SERVICE CENTRE PRIOR TO SHOW CLOSING.
- IF A COLOUR IS NOT CHOSEN, GES WILL CHOOSE A COLOUR FOR YOU. CARPET COLOUR SUBJECT TO AVAILABILITY

SUBTOTAL	
GST 5%	
TOTAL	
INCLUDE TOTAL FROM THIS PAGE ON ORDER CHECKLIST SHEET	

I HAVE READ AND UNDERSTAND THE TERMS & CONDITIONS OF MY AGREEMENT WITH GES.

SIGNATURE

DATE



7730 - 34 Street NW, Edmonton, AB T6B 3J6 Phone: 780.469.7767 Fax: 780.469.1619 Toll Free: 877.505.7767 edmonton@ges.com

BOOTH CLEANING ORDER FORM

SHOW NAME:	Uni-Select Super Show	DISCOUNT PRICE DEADLINE DATE:	Friday, February 14, 2014
SHOW DATE:	March 4, 2014	CREDIT CARD AUTHORIZATION	

EXHIBITOR INFORMATION BOOTH #: _____ COMPANY: _____ STREET: _____ CITY: _____ PROV/STATE: _____ CODE: _____ EMAIL: _____ PHONE: _____ FAX: _____ CONTACT NAME: _____	CREDIT CARD AUTHORIZATION NO ORDER WILL BE CONSIDERED FINAL UNTIL CREDIT CARD AUTHORIZATION FORM IS COMPLETED AND SUBMITTED WITH THIS FORM.
--------------------------------------------------------------------------------------------------------------------------------------------------------------------------------------------------	-----------------------------------------------------------------------------------------------------------------------------------------------------------

ALL ORDERS MUST BE PREPAID IN FULL
(ORDERS CANNOT BE PROCESSED UNTIL PAYMENT IS RECEIVED)

INITIAL CLEANING SERVICES	DAILY CLEANING SERVICES	ADDITIONAL CLEANING SERVICES
COMPLETED EVENING PRIOR TO SHOW OPENING	COMPLETED PRIOR TO SHOW OPENING AND EVERY NIGHT AT SHOW CLOSE DURING THE DURATION OF THE SHOW	COMPLETED UPON REQUEST
CARPETS VACUUMED WASTEBASKETS EMPTIED	CARPETS VACUUMED WASTEBASKETS EMPTIED	FOR CARPET IN NEED OF SPECIAL ATTENTION DUE TO FOOD SAMPLING, DEMONSTRATIONS, HAIR, WOOD, METAL SHAVINGS, GREASE OR PAINT.

RATES / SQ.FT.		RATES / SQ.FT.			RATES / SQ.FT.	
DISCOUNT PRICE	REGULAR PRICE	BOOTH SQ. FT	DISCOUNT PRICE	REGULAR PRICE	DISCOUNT PRICE	REGULAR PRICE
\$0.36	\$0.50	50 - 600 SQ.FT.	\$0.51	\$0.71	CALL FOR QUOTATION	N/A
		601 - 1000 SQ.FT.	\$0.43	\$0.60		
		OVER 1000 SQ.FT	\$0.36	\$0.50		

SELECT SERVICE REQUIRED:	<input type="checkbox"/> Initial Cleaning	<input type="checkbox"/> Daily Cleaning	<input type="checkbox"/> Additional Services
	_____ @ _____ = _____ Total Sq.Ft. of Booth Price per sq.ft. Total		

TERMS AND CONDITIONS									
- ALL ORDERS RECEIVED AFTER DISCOUNT PRICE DATE WILL BE PROCESSED AT THE REGULAR PRICE. - NO CANCELLATIONS AFTER MOVE-IN BEGINS. - ALL CLAIMS OR DISCREPANCIES MUST BE SETTLED AT THE GES SERVICE CENTRE PRIOR TO SHOW CLOSING. - ALL ORDERS ARE GOVERNED BY GES LIMITS OF LIABILITY AND RESPONSIBILITY.									
I HAVE READ AND UNDERSTAND THE TERMS & CONDITIONS OF MY AGREEMENT WITH GES.	<table border="1"> <tr><td>SUBTOTAL</td><td></td></tr> <tr><td>GST 5%</td><td></td></tr> <tr><td>TOTAL</td><td></td></tr> <tr><td colspan="2">INCLUDE TOTAL FROM THIS PAGE ON ORDER CHECKLIST SHEET</td></tr> </table>	SUBTOTAL		GST 5%		TOTAL		INCLUDE TOTAL FROM THIS PAGE ON ORDER CHECKLIST SHEET	
SUBTOTAL									
GST 5%									
TOTAL									
INCLUDE TOTAL FROM THIS PAGE ON ORDER CHECKLIST SHEET									

SIGNATURE

DATE

7730 - 34 Street NW, Edmonton, AB T6B 3J6 Phone: 780.469.7767 Fax: 780.469.1619 Toll Free: 877.505.7767 edmonton@ges.com

SHOW NAME:	Uni-Select Super Show	DISCOUNT PRICE	
SHOW DATE:	March 4, 2014	DEADLINE DATE:	Friday, February 14, 2014
EXHIBITOR INFORMATION		CREDIT CARD AUTHORIZATION	

BOOTH #: _____

COMPANY: _____

STREET: _____

CITY: _____ PROV/STATE: _____ CODE: _____

EMAIL: _____

PHONE: _____ FAX: _____

CONTACT NAME: _____

**NO ORDER WILL BE CONSIDERED
FINAL UNTIL CREDIT CARD
AUTHORIZATION FORM IS COMPLETED
AND SUBMITTED WITH THIS FORM**

**ALL ORDERS MUST BE PREPAID IN FULL
(ORDERS CANNOT BE PROCESSED UNTIL PAYMENT IS RECEIVED)**

Create a Lasting Impression!



GREEN FLOOR PLANTS				
QTY	DESCRIPTION	DISCOUNT	REGULAR	TOTAL
	2 FT. TO 5 FT. TALL	\$58.50	\$82.00	
	6 FT. TO 8 FT. TALL	\$97.50	\$137.00	
	9 FT. TO 10 FT. TALL (Indoor Tree)	CALL FOR QUOTE		
GREEN TABLE PLANTS				
	BOSTON FERN	\$51.00	\$71.00	
	TABLE PLANT - 10"	\$46.00	\$64.00	
	MUMS	\$33.00	\$46.00	
FLOWERING PLANTS & SPECIAL REQUESTS				
	STANDARD FRESH FLOWERS	CALL FOR QUOTE		
	PREMIUM FRESH FLOWERS			
	EXOTIC ARRANGEMENT			



PLEASE NOTE: Prices for flowering plants may change depending on type of flowers requested. Please List below the types of flowers you require along with any specific instructions and our Exhibitor Service Department will check on availability and price. If nothing listed, GES will provide an arrangement based on show location and time of year.

TERMS AND CONDITIONS

ALL ORDERS RECEIVED AFTER DISCOUNT PRICE DATE WILL BE PROCESSED AT THE REGULAR PRICE.
 EXHIBITOR IS RESPONSIBLE FOR ALL ITEMS FOR THE DURATION OF THE SHOW. NO REFUNDS, EXCHANGES OR CANCELLATIONS ON SITE.
 CHARGES ARE FOR RENTAL OF EQUIPMENT ONLY. ALL ITEMS REMAIN THE PROPERTY OF GES.
 ALL CLAIMS OR DISCREPANCIES MUST BE SETTLED AT THE GES SERVICE CENTRE PRIOR TO SHOW CLOSING.

SUBTOTAL	
GST 5%	
TOTAL	
INCLUDE TOTAL FROM THIS PAGE ON ORDER CHECKLIST SHEET	

I HAVE READ AND UNDERSTAND THE TERMS & CONDITIONS OF MY AGREEMENT WITH GES.

SIGNATURE

DATE

GEM SHOW SPECIAL ORDER FORM

SHOW NAME:	Uni-Select Super Show	DISCOUNT PRICE DEADLINE DATE:	Friday, February 14, 2014
SHOW DATE:	March 4, 2014	CREDIT CARD AUTHORIZATION	

EXHIBITOR INFORMATION BOOTH #: _____ COMPANY: _____ STREET: _____ CITY: _____ PROV/STATE: _____ CODE: _____ EMAIL: _____ PHONE: _____ FAX: _____ CONTACT NAME: _____	NO ORDER WILL BE CONSIDERED FINAL UNTIL CREDIT CARD AUTHORIZATION FORM IS COMPLETED AND SUBMITTED WITH THIS FORM
--------------------------------------------------------------------------------------------------------------------------------------------------------------------------------------------------	-------------------------------------------------------------------------------------------------------------------------

ALL ORDERS MUST BE PREPAID IN FULL (ORDERS CANNOT BE PROCESSED UNTIL PAYMENT IS RECEIVED)

SHOW SPECIAL !

➔ SPEND LESS
➔ SELL MORE
➔ LOOK GREAT

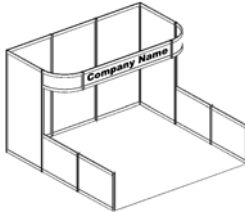
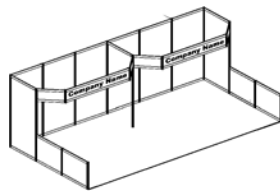
	INSTALLED & DISMANTLED READY BEFORE YOU ARRIVE NO LABOUR COSTS NO TRUCKING COSTS NO MATERIAL HANDLING COSTS INCLUDES CARPET INCLUDES HEADER SIGN(S) WHITE PANELS ACCESSORIES AVAILABLE																					
<table border="1" style="width: 100%;"> <tr> <td>DISCOUNT PRICE</td> <td style="text-align: right;">\$900.00</td> </tr> <tr> <td colspan="2">PACKAGE A: 10' X 10' BOOTH INCLUDES:</td> </tr> <tr> <td colspan="2">- HEADER SIGN 11½" X 77½"</td> </tr> <tr> <td colspan="2">- COLOR COORDINATED 10' X 10' CARPET</td> </tr> <tr> <td>REGULAR PRICE</td> <td style="text-align: right;">\$1,260.00</td> </tr> </table>	DISCOUNT PRICE	\$900.00	PACKAGE A: 10' X 10' BOOTH INCLUDES:		- HEADER SIGN 11½" X 77½"		- COLOR COORDINATED 10' X 10' CARPET		REGULAR PRICE	\$1,260.00		<table border="1" style="width: 100%;"> <tr> <td>DISCOUNT PRICE</td> <td style="text-align: right;">\$1,400.00</td> </tr> <tr> <td colspan="2">PACKAGE B: 10' X 20' BOOTH INCLUDES:</td> </tr> <tr> <td colspan="2">- 2 HEADER SIGNS 11½" X 77½"</td> </tr> <tr> <td colspan="2">- COLOR COORDINATED 10' X 10' CARPET</td> </tr> <tr> <td>REGULAR PRICE</td> <td style="text-align: right;">\$1,960.00</td> </tr> </table>	DISCOUNT PRICE	\$1,400.00	PACKAGE B: 10' X 20' BOOTH INCLUDES:		- 2 HEADER SIGNS 11½" X 77½"		- COLOR COORDINATED 10' X 10' CARPET		REGULAR PRICE	\$1,960.00
DISCOUNT PRICE	\$900.00																					
PACKAGE A: 10' X 10' BOOTH INCLUDES:																						
- HEADER SIGN 11½" X 77½"																						
- COLOR COORDINATED 10' X 10' CARPET																						
REGULAR PRICE	\$1,260.00																					
DISCOUNT PRICE	\$1,400.00																					
PACKAGE B: 10' X 20' BOOTH INCLUDES:																						
- 2 HEADER SIGNS 11½" X 77½"																						
- COLOR COORDINATED 10' X 10' CARPET																						
REGULAR PRICE	\$1,960.00																					

INDICATE DATE AND TIME YOU PLAN TO ARRIVE TO MERCHANDISE YOUR EXHIBIT _____ DATE _____ TIME _____

PLEASE COMPLETE THE FOLLOWING:

SIZE ORDERED:	<input type="checkbox"/> PACKAGE A (10 X 10)	<input type="checkbox"/> PACKAGE B (10 X 20)	
CARPET COLOUR:	<input type="checkbox"/> BLACK	<input type="checkbox"/> GREY	<input type="checkbox"/> BLUE
	<input type="checkbox"/> GREEN	<input type="checkbox"/> RED	

PACKAGE A IDENTIFICATION SIGN TO READ: _____

PACKAGE B IDENTIFICATION SIGNS TO READ: LEFT: _____ RIGHT: _____

CUSTOM HEADER TO BE ADDED **CUSTOM HEADER SIGNS / LOGOS WILL CHARGED \$100.00 EXTRA PER SIGN IF ORDERED AFTER DEADLINE DATE**

PLEASE UPLOAD GRAPHIC FILES TO: <http://www.gesexpo.ca/upload/edmonton>

(ALL CARPET COLOURS SUBJECT TO AVAILABILITY.)

TERMS AND CONDITIONS

- DOES NOT INCLUDE LIGHTING OR ELECTRICAL SERVICE.
- NO REFUNDS/EXCHANGES ONCE SHOW MOVE-IN BEGINS.
- ALL CLAIMS OR DISCREPANCIES MUST BE SETTLED AT THE GES SERVICE CENTRE PRIOR TO SHOW CLOSING.
- ALL ORDERS RECEIVED AFTER DISCOUNT PRICE DATE WILL BE PROCESSED AT THE REGULAR PRICE.
- GES IS NOT RESPONSIBLE FOR EXHIBIT MATERIALS LEFT IN GEM RENTAL EXHIBITS OR COUNTER STORAGE UNITS.
- CHANGES TO THE STRUCTURE DESIGN OR GRAPHICS WILL RESULT IN ADDITIONAL FEES.
- EXHIBITOR IS RESPONSIBLE FOR ALL ITEMS DURING THE DURATION OF THE SHOW.

SUBTOTAL	
GST 5%	
TOTAL	
INCLUDE TOTAL FROM THIS PAGE ON ORDER CHECKLIST SHEET	

I HAVE READ AND UNDERSTAND THE TERMS & CONDITIONS OF MY AGREEMENT WITH GES.

SIGNATURE

DATE

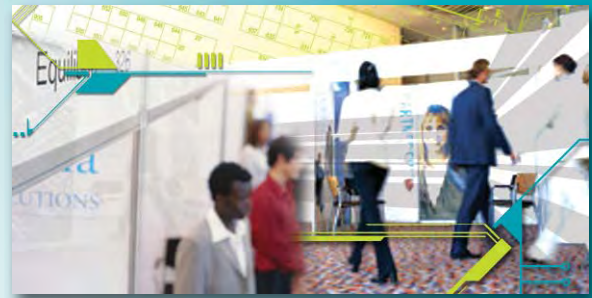

standard exhibit rentals

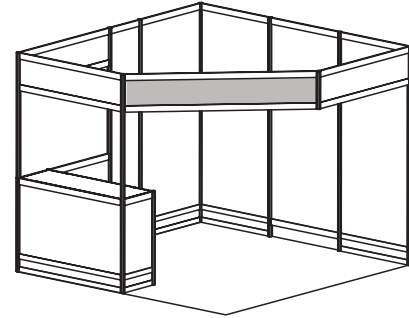

■ GEM Model #1 - 10'x10' Corner

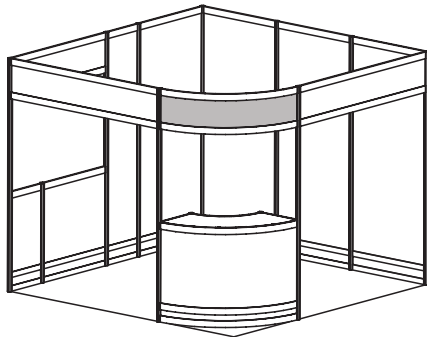

■ GEM Model #2 - 10'x10' Corner

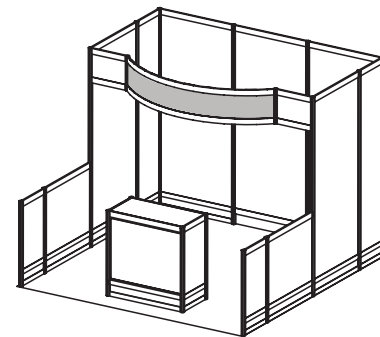

■ GEM Model #3 - 10'x10'

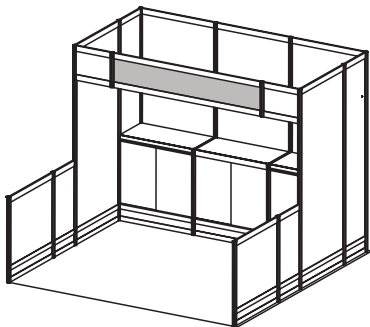

■ GEM Model #4 - 10'x10'

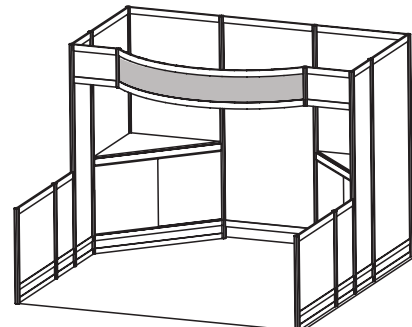

■ GEM Model #5 - 10'x10'

3 Easy Steps

- 1 Select the model number that suits your needs
- 2 Choose carpet and panel colours on the GEM Exhibit Rental order form
- 3 Complete & send order form

Grey indicates standard header sign(s)

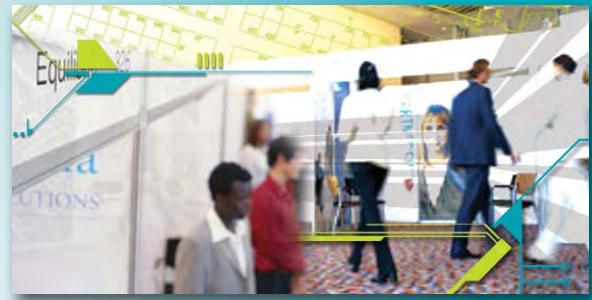

standard exhibit rentals

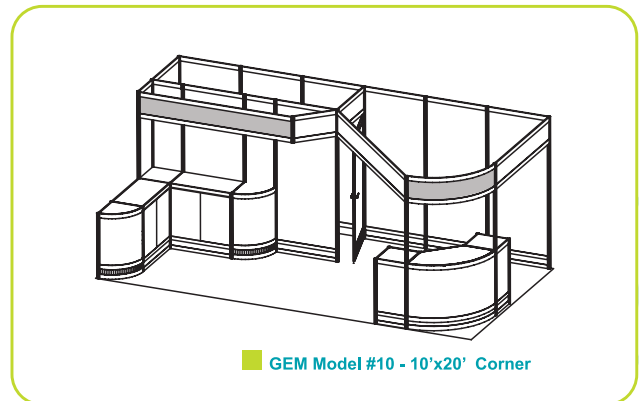
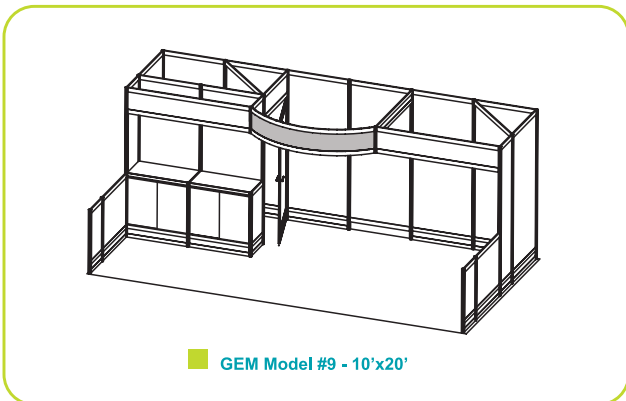
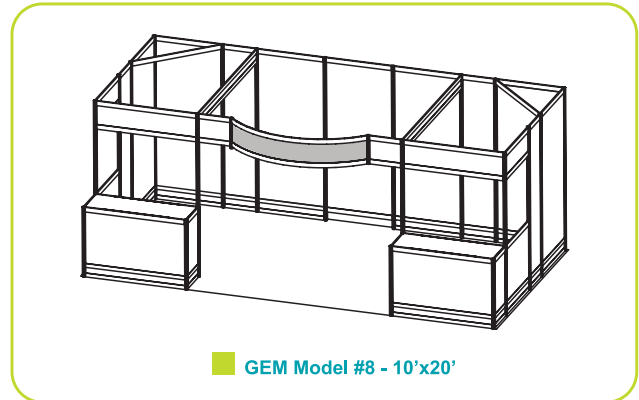
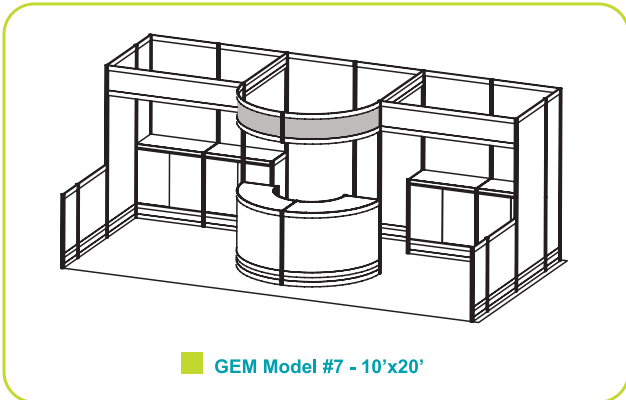
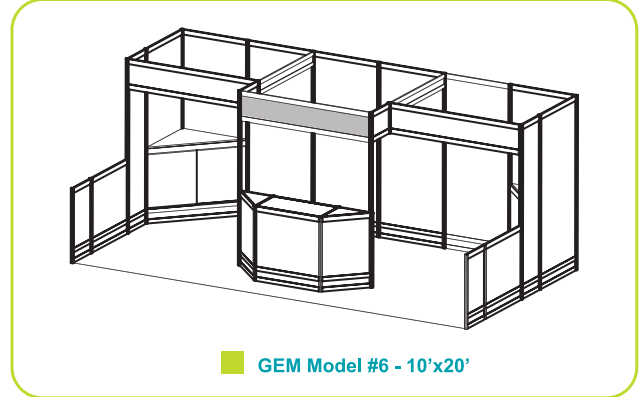

3 Easy Steps →

- 1 Select the model number that suits your needs
- 2 Choose carpet and panel colours on the GEM Exhibit Rental order form
- 3 Complete & send order form

Grey indicates standard header sign(s)

SHOW NAME:	Uni-Select Super Show	DISCOUNT PRICE	
SHOW DATE:	March 4, 2014	DEADLINE DATE:	Friday, February 14, 2014

EXHIBITOR INFORMATION	CREDIT CARD AUTHORIZATION
BOOTH #: _____ COMPANY: _____ STREET: _____ CITY: _____ PROV/STATE: _____ CODE: _____ EMAIL: _____ PHONE: _____ FAX: _____ CONTACT NAME: _____	NO ORDER WILL BE CONSIDERED FINAL UNTIL CREDIT CARD AUTHORIZATION FORM IS COMPLETED AND SUBMITTED WITH THIS FORM

**ALL ORDERS MUST BE PREPAID IN FULL
(ORDERS CANNOT BE PROCESSED UNTIL PAYMENT IS RECEIVED)**

MODEL NUMBER	DISCOUNT PRICE	REGULAR PRICE	MODEL NUMBER	DISCOUNT PRICE	REGULAR PRICE
Model #1 - 10x10 Corner	\$1,060.00	\$1,484.00	Model #6 - 10x20 Inline	\$2,105.00	\$2,947.00
Model #2 - 10x10 Corner	\$1,140.00	\$1,596.00	Model #7 - 10x20 Inline	\$2,695.00	\$3,773.00
Model #3 - 10x10 Inline	\$1,220.00	\$1,708.00	Model #8 - 10x20 Inline	\$2,255.00	\$3,157.00
Model #4 - 10x10 Inline	\$1,450.00	\$2,030.00	Model #9 - 10x20 Inline	\$2,495.00	\$3,493.00
Model #5 - 10x10 Inline	\$1,550.00	\$2,170.00	Model #10 - 10x20 Corner	\$3,025.00	\$4,235.00

**Package Includes : Installation & Dismantling, Choice of Carpet Colour, Choice of Panel Colour, Company Identification Sign
PACKAGE DOES NOT INCLUDE: Cleaning, Light Fixtures or Electrical Outlets**

PLEASE COMPLETE THE FOLLOWING:	Model Number <input style="width: 50px;" type="text"/>	<i>Upgrade options available. Contact Exhibitor Services.</i>
FONT COLOUR <input style="width: 20px; height: 20px;" type="checkbox"/> BLACK INFILL PANEL COLOUR: <input style="width: 20px; height: 20px;" type="checkbox"/> BLACK <input style="width: 20px; height: 20px;" type="checkbox"/> GREY <input style="width: 20px; height: 20px;" type="checkbox"/> WHITE <input style="width: 20px; height: 20px;" type="checkbox"/> BLUE <input style="width: 20px; height: 20px;" type="checkbox"/> RED CARPET COLOUR: <input style="width: 20px; height: 20px;" type="checkbox"/> BLACK <input style="width: 20px; height: 20px;" type="checkbox"/> GREY <input style="width: 20px; height: 20px;" type="checkbox"/> BLUE <input style="width: 20px; height: 20px;" type="checkbox"/> GREEN <input style="width: 20px; height: 20px;" type="checkbox"/> RED		

MODELS 1, 2, 3, 4, 5, 6, 8 OR 9 IDENTIFICATION SIGN TO READ: _____

MODELS 7 OR 10 IDENTIFICATION SIGN TO READ: LEFT: _____ RIGHT: _____

INDICATE DATE & TIME FOR ARRIVAL: _____

CUSTOM HEADER TO BE ADDED *CUSTOM HEADER SIGNS/LOGOS WILL BE CHARGED \$100.00 EXTRA PER SIGN IF ORDERED AFTER DEADLINE DATE*

ALL ORDERS MUST BE PREPAID IN FULL (ORDERS CAN NOT BE PROCESSED UNTIL PAYMENT IS RECEIVED)

TERMS AND CONDITIONS

PAYMENT MAY BE MADE BY CHEQUE UP TO TWO WEEKS PRIOR TO THE 1ST DAY OF MOVE IN.
 ALL ORDERS RECEIVED AFTER THE DISCOUNT PRICE DATE WILL BE PROCESSED AT THE REGULAR PRICE.
 EXHIBITOR IS RESPONSIBLE FOR ALL ITEMS FOR THE DURATION OF THE SHOW.
 CHARGES ARE FOR RENTAL OF EQUIPMENT ONLY. ALL ITEMS REMAIN PROPERTY OF GES.
 NO REFUNDS/EXCHANGES ONCE SHOW MOVE-IN BEGINS. ALL CLAIMS OR DISCREPANCIES MUST BE SETTLED PRIOR TO SHOW CLOSING.
 GES IS NOT RESPONSIBLE FOR EXHIBIT MATERIALS LEFT IN GEM RENTAL EXHIBITS OR COUNTER STORAGE UNITS.
 CHANGES TO THE STRUCTURE DESIGN OR GRAPHICS WILL RESULT IN ADDITIONAL FEES.

SUBTOTAL	
GST 5%	
TOTAL	
INCLUDE TOTAL FROM THIS PAGE ON ORDER CHECKLIST SHEET	

I HAVE READ AND UNDERSTAND THE TERMS & CONDITIONS OF MY AGREEMENT WITH GES.

SIGNATURE







DATE

7730 - 34 Street NW, Edmonton, AB T6B 3J6 Phone: 780.469.7767 Fax: 780.469.1619 Toll Free: 877.505.7767 edmonton@ges.com

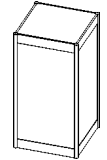
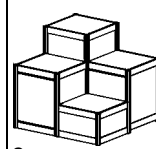
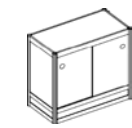
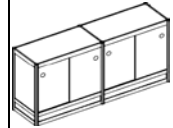
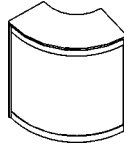
SHOW NAME:	Uni-Select Super Show	DISCOUNT PRICE	Friday, February 14, 2014
SHOW DATE:	March 4, 2014	DEADLINE DATE:	

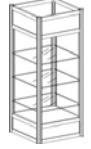
<p style="text-align: center;">EXHIBITOR INFORMATION</p> <p>BOOTH #: _____</p> <p>COMPANY: _____</p> <p>STREET: _____</p> <p>CITY: _____ PROV/STATE: _____ CODE: _____</p> <p>EMAIL: _____</p> <p>PHONE: _____ FAX: _____</p> <p>CONTACT NAME: _____</p>	<p style="text-align: center;">CREDIT CARD AUTHORIZATION</p> <p style="font-size: 1.2em; font-weight: bold;">NO ORDER WILL BE CONSIDERED FINAL UNTIL CREDIT CARD AUTHORIZATION FORM IS COMPLETED AND SUBMITTED WITH THIS FORM</p>
------------------------------------------------------------------------------------------------------------------------------------------------------------------------------------------------------------------------------------------------------------------------	------------------------------------------------------------------------------------------------------------------------------------------------------------------------------------------------------------------------------------------------------

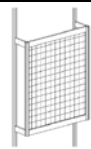
ALL ORDERS MUST BE PREPAID IN FULL
(ORDERS CANNOT BE PROCESSED UNTIL PAYMENT IS RECEIVED)

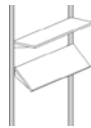
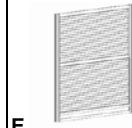
QTY	#	DESCRIPTION	DISCOUNT	REGULAR	TOTAL					
	1	Pedestal 20"L x 20"W 28"H OR 36"H	\$82.00	\$115.00		1				
	2	Pedestal 40"L x 40"W	\$412.00	\$577.00						
	3	Counter Storage Unit 40"L X 20"W X 40"H	\$125.00	\$343.00						
	4	Storage Counter 80"L x 20"W x 40"H	\$245.00	\$343.00						
	5	Curved Counter 60"L x 20"W x 40"H	\$168.00	\$235.00		5				
	6	99A Showcase 40"L x 20"W x 40"H	\$168.00	\$235.00						
	7	99B Showcase 40"L x 20"W x 40"H	\$171.00	\$239.00						
	8	99C Showcase 26"L x 26"W x 96"H	\$248.00	\$347.00						
	9	99D Showcase 40"L x 20"W x 96"H	\$350.00	\$490.00						
QTY	#	DESCRIPTION	DISCOUNT	REGULAR	TOTAL					
	A	Waterfall with Eight Balls	\$16.50	\$23.00						
	B	Grid Panels - 38" W x 44"H Panels	\$115.00	\$161.00		9		A	B	C
	C	Garment Rail 39"W	\$42.50	\$60.00						
	D	Shelves, Flat or Angled 37"L x 12"W	\$36.00	\$50.00						
	E	Slatwall Panels - 37"W x 96"H Grey	\$99.00	\$139.00					Accessories A to E are designed to fit GES Hardwall Only	
ADDITIONAL ITEMS NOTE SHOWN									All Units Include White Panels	
		Ballot Bin - 20"L X 20"W X 36"H	\$108.00	\$50.00					Please attach diagram of booth indicating locations for grid panels and / or slatwall. Grid panels CANNOT be installed in corners.	
		Computer Counter	\$142.00	\$139.00						

TERMS AND CONDITIONS

- DOES NOT INCLUDE LIGHTING OR ELECTRICAL SERVICE.
- NO REFUNDS/EXCHANGES ONCE SHOW MOVE-IN BEGINS.
- ALL CLAIMS OR DISCREPANCIES MUST BE SETTLED AT THE GES SERVICE CENTRE PRIOR TO SHOW CLOSING.
- ALL ORDERS RECEIVED AFTER DISCOUNT PRICE DATE WILL BE PROCESSED AT THE REGULAR PRICE.
- GES IS NOT RESPONSIBLE FOR EXHIBIT MATERIALS LEFT IN GEM RENTAL EXHIBITS OR COUNTER STORAGE UNITS.
- CHANGES TO THE STRUCTURE DESIGN OR GRAPHICS WILL RESULT IN ADDITIONAL FEES.
- EXHIBITOR IS RESPONSIBLE FOR ALL ITEMS DURING THE DURATION OF THE SHOW.

SUBTOTAL	
GST 5%	
TOTAL	
INCLUDE TOTAL FROM THIS PAGE ON ORDER CHECKLIST SHEET	

I HAVE READ AND UNDERSTAND THE TERMS & CONDITIONS OF MY AGREEMENT WITH GES.

SIGNATURE

DATE

GRAPHICS ORDER FORM

SHOW NAME:	Uni-Select Super Show	DISCOUNT PRICE	
SHOW DATE:	March 4, 2014	DEADLINE DATE:	Friday, February 14, 2014
EXHIBITOR INFORMATION		CREDIT CARD AUTHORIZATION	

BOOTH #: _____

COMPANY: _____

STREET: _____

CITY: _____ PROV/STATE: _____ CODE: _____

EMAIL: _____

PHONE: _____ FAX: _____

CONTACT NAME: _____

**NO ORDER WILL BE CONSIDERED
FINAL UNTIL CREDIT CARD
AUTHORIZATION FORM IS COMPLETED
AND SUBMITTED WITH THIS FORM**

**ALL ORDERS MUST BE PREPAID IN FULL
(ORDERS CANNOT BE PROCESSED UNTIL PAYMENT IS RECEIVED)**

SIGN LAYOUT	QTY	SIGN SIZES	DISCOUNT PRICE	REGULAR PRICE
		11" x 14"	\$41.00	\$57.00
		14" x 22"	\$57.00	\$80.00
		22" x 28"	\$89.00	\$125.00
		7" x 44"	\$57.00	\$80.00
		28" x 44"	\$153.00	\$214.00
		40" x 60"	\$233.00	\$326.00
			Layout & Design Work / Hour	\$80.00

**CUSTOM ARTWORK / LOGOS MUST BE ORDERED NO LATER THAN 5 BUSINESS DAYS PRIOR TO FIRST DAY OF MOVE-IN
PLEASE PRINT OR TYPE THE TEXT REQUIRED:**

PLEASE INDICATE FONT TYPE: _____

**ALL SIGNS MUST BE PICKED UP FROM OUR ON-SITE EXHIBITOR SERVICES DESK
Custom sizes available - Call for quotation.
TERMS AND CONDITIONS**

ALL ORDERS RECEIVED AFTER THE DISCOUNT PRICE DATE WILL BE PROCESSED AT THE REGULAR PRICE.
THERE ARE NO REFUNDS / EXCHANGES ON SIGNS UNLESS ERROR LIES WITH GES PRODUCTION.
NO REFUNDS/EXCHANGES ONCE SHOW MOVE-IN BEGINS. ALL CLAIMS OR DISCREPANCIES MUST BE SETTLED PRIOR TO SHOW CLOSING.

I HAVE READ AND UNDERSTAND THE TERMS & CONDITIONS OF MY AGREEMENT WITH GES.

SUBTOTAL	
GST 5%	
TOTAL	
INCLUDE TOTAL FROM THIS PAGE ON ORDER CHECKLIST SHEET	

SIGNATURE

DATE

7730 - 34 Street NW, Edmonton, AB T6B 3J6 Phone: 780.469.7767 Fax: 780.469.1619 Toll Free: 877.505.7767 edmonton@ges.com

SHOW NAME:	Uni-Select Super Show	DISCOUNT PRICE	
SHOW DATE:	March 4, 2014	DEADLINE DATE:	Friday, February 14, 2014

EXHIBITOR INFORMATION	CREDIT CARD AUTHORIZATION
BOOTH #: _____ COMPANY: _____ STREET: _____ CITY: _____ PROV/STATE: _____ CODE: _____ EMAIL: _____ PHONE: _____ FAX: _____ CONTACT NAME: _____	<p style="font-size: 1.2em; margin: 0;">NO ORDER WILL BE CONSIDERED FINAL UNTIL CREDIT CARD AUTHORIZATION FORM IS COMPLETED AND SUBMITTED WITH THIS FORM</p>

ALL ORDERS MUST BE PREPAID IN FULL (ORDERS CANNOT BE PROCESSED UNTIL PAYMENT IS RECEIVED)

LABOUR RATES LISTED ARE PER PERSON PER HOUR AT A **MINIMUM CHARGE OF ONE (1) HOUR**. LABOUR OVER ONE (1) HOUR IS CHARGED IN HALF (1/2) HOUR INCREMENTS.
A 40% SURCHARGE WILL BE APPLIED TO ONSITE ORDERS

STRAIGHT TIME
 Monday - Friday
 8:00am - 4:00pm

DISCOUNT PRICE:
\$65.00

REGULAR PRICE:
\$91.00

OVERTIME
 Monday - Friday
 4:00pm-6:00pm

 Saturday - Sunday
 8:00am-4:00pm

DISCOUNT PRICE:
\$97.50

REGULAR PRICE:
\$137.00

EXHIBITOR MUST REPORT TO GES SERVICE CENTRE TO RECEIVE THEIR LABOUR

INSTALLATION Set up Drawings or Photos Attached: YES NO

Carrier: _____ Delivery Date: _____ Delivery time: _____
(Day/Date/Month/Year) (indicate am or pm)

SUPERVISION By Exhibitor (Provide Name of Rep) By GES (30% Surcharge Applies)
(Exhibitor MUST be Present to Supervise) (Exhibitor Does not have to be present)

Date Labour Required: _____ Start time Required: _____ AM PM
(Day/ Date/Month/Year)

Number of People Required: X Hours Per Person = Total Hours

DISMANTLING

Carrier: _____ Delivery Date: _____ Delivery time: _____
(Day/Date/Month/Year) (indicate am or pm)

SUPERVISION By Exhibitor (Provide Name of Rep) By GES (30% Surcharge Applies)
(Exhibitor MUST be Present to Supervise) (Exhibitor Does not have to be present)

Date Labour Required: _____ Start time Required: _____ AM PM
(Day/ Date/Month/Year)

Number of People Required: X Hours Per Person = Total Hours

TERMS AND CONDITIONS

WHEN EXHIBITOR IS SUPERVISING LABOUR THE EXHIBITOR MUST CHECK LABOUR IN AND OUT AT THE GES SERVICE CENTRE.
 WE RESERVE THE RIGHT TO CHANGE LABOURERS AND/OR RATES AS SHIFTS CHANGE.
 ALL CLAIMS OR DISCREPANCIES MUST BE SETTLED AT THE GES SERVICE CENTRE PRIOR TO SHOW CLOSING.
 UNCANCELLED LABOUR WILL BE CHARGED A MINIMUM FEE OF 1 HOUR PER PERSON.
 GES LIMITS OF LIABILITY APPLY

SUBTOTAL	
GST 5%	
TOTAL	
INCLUDE TOTAL FROM THIS PAGE ON ORDER CHECKLIST SHEET	

I HAVE READ AND UNDERSTAND THE TERMS & CONDITIONS OF MY AGREEMENT WITH GES.

 SIGNATURE DATE

IN-BOOTH FORKLIFT SERVICE ORDER FORM

SHOW NAME:	Uni-Select Super Show	DISCOUNT PRICE	
SHOW DATE:	March 4, 2014	DEADLINE DATE:	Friday, February 14, 2014

<p>EXHIBITOR INFORMATION</p> <p>BOOTH #: _____</p> <p>COMPANY: _____</p> <p>STREET: _____</p> <p>CITY: _____ PROV/STATE: _____ CODE: _____</p> <p>EMAIL: _____</p> <p>PHONE: _____ FAX: _____</p> <p>CONTACT NAME: _____</p>	<p>CREDIT CARD AUTHORIZATION</p> <p>NO ORDER WILL BE CONSIDERED FINAL UNTIL CREDIT CARD AUTHORIZATION FORM IS COMPLETED AND SUBMITTED WITH THIS FORM</p>
-------------------------------------------------------------------------------------------------------------------------------------------------------------------------------------------------------------------------------------	------------------------------------------------------------------------------------------------------------------------------------------------------------------------

CREDIT CARD AUTHORIZATION (ABOVE) MUST BE COMPLETED AS METHOD OF PAYMENT FOR THIS SERVICE

IN-BOOTH FORKLIFT SERVICE IS AVAILABLE TO EXHIBITORS REQUIRING ASSISTANCE WITH POSITIONING OF EXHIBITORS MATERIAL **WITHIN YOUR YOUR BOOTH SPACE**. **MINIMUM CHARGE OF ONE HOUR** PER SHIPMENT **PER FORKLIFT DRIVER**. SERVICES OVER ONE (1) HOUR WILL BE CHARGED IN HALF (1/2) HOUR INCREMENTS (INCLUDES MOVE-IN AND MOVE-OUT)

THIS SERVICE IS NOT PAID FOR BY SHOW MANAGEMENT

ALL RATES INCLUDE ONE (1) FORKLIFT AND DRIVER - ADDITIONAL RATES WILL APPLY FOR ADDITIONAL PERSONNEL AND EQUIPMENT

<p>STRAIGHT TIME Monday - Friday 8:00am - 4:00pm</p>	<p>DISCOUNT PRICE: \$99.00</p> <p>REGULAR PRICE: \$139.00</p>	<p>OVERTIME Monday - Friday 4:00pm-6:00pm Saturday - Sunday</p>	<p>DISCOUNT PRICE: \$148.50</p> <p>REGULAR PRICE: \$208.00</p>
---------------------------------------------------------------------	-----------------------------------------------------------------------------	------------------------------------------------------------------------------------	------------------------------------------------------------------------------

A 40% SURCHARGE WILL APPLY TO ALL ONSITE ORDERS

ALL RATES INCLUDE FORKLIFT AND DRIVER (5% GST IS APPLICABLE)

PLEASE COMPLETE THE FOLLOWING

SUPERVISOR NAME: _____ (EXHIBITOR **MUST** BE PRESENT TO SUPERVISE)

INSTALLATION TIME REQUIRED: _____

DAY DATE MONTH # of HOURS #of FORKLIFTS

DISMANTLING TIME REQUIRED: _____

DAY DATE MONTH # of HOURS #of FORKLIFTS

APPROXIMATE TIMES ONLY - FORKLIFTS WILL BE DISPATCHED BY REQUEST PLACED AT EXHIBITOR SERVICES DESK ONSITE

MOVE-IN	START:	<input type="checkbox"/> AM	<input type="checkbox"/> PM	FINISH:	<input type="checkbox"/> AM	<input type="checkbox"/> PM	TOTAL HOURS: _____
MOVE-OUT	START:	<input type="checkbox"/> AM	<input type="checkbox"/> PM	FINISH:	<input type="checkbox"/> AM	<input type="checkbox"/> PM	TOTAL HOURS: _____

SERVICES OVER 1 HOUR MINIMUM WILL BE CHARGED IN 1/2 HOUR INCREMENTS PER FORKLIFT

TERMS AND CONDITIONS

- EXHIBITOR MUST CHECK FORKLIFT / DRIVER IN AND OUT AT THE GES SERVICE CENTRE.
 - WE RESERVED THE RIGHT TO CHANGE LABOURERS AND / OR RATES AS SHIFTS CHANGE.
 - FORKLIFT OPERATORS RESERVE THE RIGHT TO REFUSE UNSAFE REQUESTS OR LIFTS AT ALL TIMES.
 - IT IS THE EXHIBITORS RESPONSIBILITY TO SECURE AND MAINTAIN LOSS & DAMAGE INSURANCE COVERAGE FOR THEIR EXHIBIT PROPERTIES.
 - ALL CLAIMS OR DISCREPANCIES MUST BE SETTLED AT THE GES SERVICE CENTRE PRIOR TO SHOW CLOSING
 - GES LIMITS OF LIABILITY & RESPONSIBILITY APPLY TO THIS SERVICE.
- I HAVE READ AND UNDERSTAND THE TERMS & CONDITIONS OF MY AGREEMENT WITH GES.

SUBTOTAL	
GST 5%	
TOTAL	
INCLUDE TOTAL FROM THIS PAGE ON ORDER CHECKLIST SHEET	

_____ SIGNATURE	_____ DATE
--------------------	---------------

GES MATERIAL HANDLING TERMS & CONDITIONS

Material Handling is the unloading of your exhibit materials, delivery to your booth, handling of empty containers to and from storage, and removal of your materials from your booth for reloading onto your outbound carrier. This is not to be confused with the cost to transport your exhibit material to and from the event.

Benefits of Advance Shipping to the GES Warehouse

- Storage of materials for up to 30 days prior to your show.
- Delivery of Shipments to your booth by 8:00 AM on your first day of move-in (schedule permitting).
- Some convention centres and hotels do not have facilities for receiving or storing freight.
- Saves valuable set-up time.

How to ship in Advance to the GES Warehouse

- Complete Direct to Showsite Material Handling order form.
- Remove all old shipping and empty storage labels.
- Fill out and attach enclosed Advance Shipping Labels.
- Complete the enclosed Advance Material Handling order form.
- All shipments must have a bill of lading or delivery slip showing the number of pieces, weight, and type of merchandise.
- Take the time to ensure that your display and products are packed neatly and securely.
- Do not ship uncrated materials to the warehouse.

How to Ship to Exhibit Site

- Consign all shipments c/o GES.
- Remove all old shipping and empty storage labels.
- Fill out and attach enclosed Direct Shipping labels.
- All shipments must have a bill of lading or delivery slip showing the number of pieces, weight, and type of merchandise.
- Take the time to ensure that your display and products are packed neatly and securely.
- If you are shipping your carpet and/or lighting trusses, make sure it is loaded last so it can be unloaded first.

Freight Carriers

Select a carrier with experience in handling exhibition materials. Make sure to give your carrier explicit information as to where and when to check-in. Delivery and pick up times are often out of the range of "normal" deliver hours, make sure your carrier is committed to meeting your target dates and times. While making shipping plans to the Show, also plan for the return shipment.

Tracking Shipments

Confirm your delivery date and time with your carrier, and have all pertinent shipping information in the hands of your representative at showsite. You may also want to review the return of your goods prior to end of the show.

Estimating Material Handling Charges

Handling charges are based on the weight of the freight. Shipments are billed by the hundred weight and rounded up to the nearest hundred. Minimum per shipment may apply, see enclosed Material Handling Order Form for details. Please prepay all shipping charges - GES cannot accept or be responsible for collect shipments. Crated and uncrated shipments must be separated and clearly identified on your bill of lading.

- **Crated** - Material that is skidded, or is any type of shipping container that can be unloaded at the dock with no additional handling required.
- **Uncrated** - Material that is shipped loose or pad-wrapped, and/or unskidded machinery without proper lifting bars or hooks.
- **Special Handling** - Defined as shipments that are loaded by cubic space and/or packed in such a manner as to require special handling, such as ground loading, side door loading, constricted space loading, and designated piece loading or stacked shipments. Also included are mixed shipments and shipments without proper delivery receipts.

- **Overtime Surcharges** - Shows that move-in or move-out on weekends or late in the day may be subject to overtime surcharges. See enclosed Material Handling Order Form for details.

- **Late Surcharges** - A surcharge may apply if advance freight is received after the published deadline date for shipments to arrive at the warehouse. See enclosed Material Handling Order Form for details.

Storing Empty Containers

Properly labeled empty shipping cartons will be picked up, stored and returned after the show. Labels are available at the **GES Servicentre** or from your GES Service Executive and are for empty storage only. Depending on the size of the show, it can take from one (1) to four (4) hours to return empty crates. Do not store any items in crates marked empty.

Outgoing Shipments

An OMHF (Outbound Material Handling Form / Bill of Lading) must accompany all outgoing shipments. Shipping information, outbound forms and labels will be available at the **GES Servicentre**. Exhibitors selecting non-official carriers will need to make their own arrangements for pickup. Make sure that someone from your company will be on-site to oversee the outbound shipment of your display and product.

Machinery Labour and Equipment

Labour and equipment for uncrating, unskidding, positioning, leveling, dismantling, reerating, and reskidding machinery and/or equipment must be ordered separately. Place your order for this using the In-Booth Forklift and Labour Order Form. If you material requires specialized rigging equipment, please notify us promptly so that we can make arrangements. When possible supply your own rigging equipment with shipments and pre-rig your material

Insurance

All of your goods should be insured by your own insurance policy. Although we do our best to handle your goods as our own, there are many variables in shipping and handling that can affect your exhibit and products. GES has published GES Terms & Conditions of Contract that are in your exhibitor service manual. Please read them carefully. It is recommended that your goods be insured.

Customs & Brokerage Fees

GES is not responsible for the brokerage fees, duty or GST resulting from exhibitor materials entering Canada from another country. GES is not responsible for any delays in delivery of exhibitor materials to show site or the advance warehouse due to Canada Custom inspections or delays resulting from insufficient or improper documentation for shipments entering Canada from another country.

GES CANADA Limits of Liability

- **Liability** - GES is liable for loss or damage to your goods ONLY if the loss or damage was caused by GES negligence.
- **Measure of Damage** - If GES was negligent and the negligence caused either loss or damage to your goods, then the measure of that damage will be determined by the following:
 - a. Measure of damages in all situations (including b. below) will be limited by the Depreciated Value of the goods or repair costs, whichever is less.
 - b. The lesser of \$0.30 per pound per piece, \$50 per piece, or \$1000 per occurrence.

GES does not offer or sell insurance. GES is not liable and will not owe for loss or damage to your goods if the damage was not caused by GES.



7730 - 34 Street NW, Edmonton, AB T6B 3J6 Phone: 780.469.7767 Fax: 780.469.1619 Toll Free: 877.505.7767 edmonton@ges.com

MATERIAL HANDLING ORDER FORM

SHOW NAME:	Uni-Select Super Show	DISCOUNT PRICE	
SHOW DATE:	March 4, 2014	DEADLINE DATE:	Friday, February 14, 2014

EXHIBITOR INFORMATION	CREDIT CARD AUTHORIZATION
BOOTH #: _____ COMPANY: _____ STREET: _____ CITY: _____ PROV/STATE: _____ CODE: _____ EMAIL: _____ PHONE: _____ FAX: _____ CONTACT NAME: _____	<p>NO ORDER WILL BE CONSIDERED FINAL UNTIL CREDIT CARD AUTHORIZATION FORM IS COMPLETED AND SUBMITTED WITH THIS FORM</p>

**CREDIT CARD AUTHORIZATION (ABOVE) MUST BE COMPLETED AS
METHOD OF PAYMENT FOR THIS SERVICE**

ADVANCE SHIPMENT(S) TO WAREHOUSE:

- Shipment(s) must be received by: Thursday, February 27, 2014			
- Estimated Weight for Shipment(s) - Rounded up to the nearest 100 lbs:	POUNDS		
- Advance Warehouse Rate: \$57.50 per 100 lbs. (200lb min. charge)			

DIRECT SHIPMENT(S) TO SHOWSITE:

	Straight Time	Over Time
- Direct to Show Site Rate:	Monday - Friday 8:00am - 4:00pm	Monday-Friday 4:00pm - 6:00pm, Saturday, Sunday
- Shipment(s) may arrive at showsite on or after:	\$99.00 per hour. (1 hour min. charge)	\$148.50 per hour. (1hour min. charge)
Monday, March 03, 2014		

POST SHOW STORAGE SERVICE:

- Post Show Storage Rate of: \$45.00 per 100 lbs. (200lb min. charge)			
- This service includes transport back to the advance warehouse address only.	POUNDS		
- Shipments may be picked up starting on: Friday, March 07, 2014			*Any shipments not picked up after 3 days will be considered forced freight and subject to additional storage charges.

SPECIAL HANDLING: (40% Surcharge Applies to the Entire Shipment)

- Shipments of loose, padded or uncrated materials
- Special unloading requirements, such as ground and / or side door unloading, constricted or stacked unloading.
- All Direct and Advance Shipments without certified weight ticket or proven inaccurate weight ticket.
- Shipments arriving outside of target dates.
- Services ordered after the deadline date

SMALL PACKAGES: (Maximum 50 lbs / Shipment)

- Rate of: \$37.00 for the First Package	
- Rate of: \$9.25 for each additional package(s) (in the same shipment) to a 50lb. Maximum	
if shipment is over 50lbs, rates for advance or direct will apply.	

PLEASE COMPLETE THE FOLLOWING:

Carrier Name: _____	Number of Pieces: _____	Total Weight _____
Goods are scheduled for delivery to:	Show Site	Advance Warehouse
Date goods are scheduled to arrive: _____	Month/Day	

TERMS AND CONDITIONS

- COLLECT SHIPMENTS WILL NOT BE ACCEPTED.
- GES IS NOT RESPONSIBLE FOR CONCEALED DAMAGE, DAMAGE TO LOOSE OR INADEQUATELY PACKED SHIPMENTS OR LOSS OF MERCHANDISE AFTER DELIVERY TO BOOTH
- IT IS THE EXHIBITORS RESPONSIBILITY TO SECURE AND MAINTAIN LOSS & DAMAGE INSURANGCE COVERAGE FOR THEIR EXHIBIT PROPERTIES.
- ALL CLAIMS OR DISCREPANCIES MUST BE SETTLED AT THE GES SERVICE CENTRE PRIOR TO SHOW CLOSING
- GES LIMITS OF LIABILITY & RESPONSIBILITY APPLY TO THIS SERVICE.

I HAVE READ AND UNDERSTAND THE TERMS & CONDITIONS OF MY AGREEMENT WITH GES.

SUBTOTAL	
GST 5%	
TOTAL	
INCLUDE TOTAL FROM THIS PAGE ON ORDER CHECKLIST SHEET	

SIGNATURE

DATE

ADVANCE WAREHOUSE SHIPPING LABEL

NAME OF SHOW: Uni-Select Super Show

FACILITY: River Cree Resort

EXHIBIT SHIPMENT FOR ADVANCE WAREHOUSE

SHIPPER:

(NAME OF COMPANY WHERE SHIPMENT ORIGINATES)

TO:

(NAME OF EXHIBITING COMPANY AT THE SHOW.)

BOOTH #

(BOOTH NUMBER AT THE SHOW.)

ADVANCE WAREHOUSE ADDRESS	GES Edmonton 7730 - 34 Street NW Edmonton, AB T6B 3J6
------------------------------------------	----------------------------------------------------------------

CARRIER:

(NAME OF TRANSPORTATION COMPANY)

NUMBER **OF** **PIECES**

ADVANCE WAREHOUSE SHIPMENTS SHOULD ARRIVE BEFORE:

Thursday, February 27, 2014

BETWEEN 9AM AND 4PM MONDAY - FRIDAY

DIRECT TO SHOW SITE SHIPPING LABEL

NAME OF SHOW:	Uni-Select Super Show
FACILITY:	River Cree Resort

EXHIBIT SHIPMENT FOR DIRECT TO SHOWSITE

SHIPPER:

(NAME OF COMPANY WHERE SHIPMENT ORIGINATES)

TO:

(NAME OF EXHIBITING COMPANY AT THE SHOW.)

BOOTH #

(BOOTH NUMBER AT THE SHOW.)

SHOWSITE ADDRESS	River Cree Resort 300 East Lapotac Blvd Enoch, AB T7X 3Y3
-----------------------------	--------------------------------------------------------------------

CARRIER:

(NAME OF TRANSPORTATION COMPANY)

NUMBER **OF** **PIECES**

DIRECT TO SHOW SITE SHIPMENTS TO ARRIVE ON:

Monday, March 03, 2014

DURING EXHIBITOR MOVE-IN TIMES

SHOW NAME:	Uni-Select Super Show	DISCOUNT PRICE	
SHOW DATE:	March 4, 2014	DEADLINE DATE:	Friday, February 14, 2014

EXHIBITOR INFORMATION	CREDIT CARD AUTHORIZATION
BOOTH #: _____ COMPANY: _____ STREET: _____ CITY: _____ PROV/STATE: _____ CODE: _____ EMAIL: _____ PHONE: _____ FAX: _____ CONTACT NAME: _____	<p>NO ORDER WILL BE CONSIDERED FINAL UNTIL CREDIT CARD AUTHORIZATION FORM IS COMPLETED AND SUBMITTED WITH THIS FORM.</p>

**ALL ORDERS MUST BE PREPAID IN FULL
(ORDERS CANNOT BE PROCESSED UNTIL PAYMENT IS RECEIVED)**

ELECTRICAL - 110 VOLT

QTY.	DESCRIPTION	DISCOUNT PRICE	REGULAR PRICE	TOTAL
	1500 WATT DUPLEX OUTLET	\$69.00	\$97.00	

ELECTRICAL - 220 VOLT SINGLE PHASE

	220 V / 20 AMP SINGLE PHASE	\$154.50	\$216.00	
	220 V / 30 AMP SINGLE PHASE	\$185.00	\$259.00	
	220 V / 50 AMP SINGLE PHASE	\$231.00	\$323.00	
	220 V 100 AMP SINGLE PHASE	\$415.00	\$581.00	

ELECTRICAL - MISCELLANEOUS REQUIREMENTS

	POWER BAR	\$16.50	\$23.00	
	EXTENSION CORD	\$18.50	\$26.00	

LIGHTING (DOES NOT INCLUDE POWER)

	FLOOD LIGHT STAND C/W 2 - 75 WATT FLOOD BULBS	\$61.50	\$86.00	
	CLAMP-ON LIGHT C/W 1 - 75 WATT FLOOD BULB	\$26.75	\$37.00	
	500 WATT QUARTZ LIGHT	\$79.00	\$111.00	
	SPECIAL HOOKUPS AND LIGHTING UPON REQUEST	CALL FOR QUOTATION		

PLEASE NOTE FOLLOWING WHERE ADDITIONAL CHARGES MAY APPLY

24 HOUR POWER REQUIRED - ADD 50% TO ABOVE PRICES.	ELECTRICIAN CHARGE IF REQUIRED - CALL FOR QUOTATION
OUTDOOR POWER - ADD 100% TO ABOVE PRICES.	SPECIAL WIRING OR CONNECTIONS - CALL FOR QUOTATION

TERMS AND CONDITIONS

- ALL ORDERS RECEIVED AFTER DISCOUNT PRICE DATE WILL BE PROCESSED AT THE REGULAR PRICE.
- EXHIBITOR IS RESPONSIBLE FOR ALL ITEMS DURING THE DURATION OF THE SHOW.
- NO REFUNDS/EXCHANGES ON POWER ONCE DELIVERED.
- CHARGES ARE FOR RENTAL OF EQUIPMENT ONLY. ALL ITEMS REMAIN THE PROPERTY OF GES.
- ALL CLAIMS OR DISCREPANCIES MUST BE SETTLED AT THE GES SERVICE CENTRE PRIOR TO SHOW CLOSING.
- GES RESERVES THE RIGHT TO REFUSE TO PROVIDE UNSAFE CONNECTIONS.

SUBTOTAL	
GST 5%	
TOTAL	
INCLUDE TOTAL FROM THIS PAGE ON ORDER CHECKLIST SHEET	

I HAVE READ AND UNDERSTAND THE TERMS & CONDITIONS OF MY AGREEMENT WITH GES.

SIGNATURE

DATE

I. Definitions:

Agents: GES's agents, sub-contractors, carriers, and the agents of each.

Customer: Exhibitor or other party requesting services from GES.

Carrier: Motor carrier, van line, air carrier, or air or surface carrier/freight forwarder.

Shipper: Party who tenders Goods to Carrier for transportation.

Goods: Exhibits, property, and commodities of any type for which GES is requested to perform services.

Cold Storage: Holding of Goods in a climate controlled area.

Accessible Storage: Holding of Goods in an area from which Goods may be removed during shows.

Services: Warehousing, transportation, drayage, un-supervised labour, supervised labour and/or related services.

Show Site: The venue or place where an exposition or event takes place.

Supervised Labour: Labour that is provided to a Customer to install or dismantle a booth or exhibit space, and is supervised and/or directed by GES.

Un-Supervised Labour: Labour that is provided to a Customer to install or dismantle a booth or exhibit space and per Customer's election is not supervised and/or directed by GES. Customer assumes the responsibility for the work of labour when Customer elects to use unsupervised labour.

II. Scope:

These Terms and Conditions shall be binding upon Customer, GES, and their respective Agents and representatives, including but not limited to Customer contracted labour such as Customer Appointed Contractors and Installation and Dismantle Companies, and any other party with an interest in the Goods. Each shall have the benefit of and be bound by all provisions stated herein, including but not limited to time limits and limitations of liability.

By acceptance of services of GES or Agents, Customer and any other party with an interest in the Goods agree to these Terms and Conditions.

III. Customer Obligations:

Payment for Services. Customer shall be liable for all unpaid charges for services performed by GES or Agents. Customer authorizes GES to charge its' credit card directly for services rendered on its' behalf after departure, by placing an order on-line, via fax, phone, or through a work order on site.

Credit Terms. All charges are due before Services are performed unless other arrangements have been made in advance. GES has the right to require prepayment or guarantee of the charges at the time of request for Services. A failure to pay timely will result in Customer having to pay in cash in advance for future services. If a credit provided to GES, GES is authorized to bill to such credit card any unpaid charges for services provided Customer, including charges for return shipping. Any charges not paid within 30 days of deliver will be subject to interest at 1.5% per month until paid.

IV. Mutual Obligations:**Indemnification:**

Customer to GES: Except to the extent of GES's own negligence and/or willful misconduct, Customer shall defend, hold harmless and indemnify GES from and against any claims, lawsuits, demands, liability, costs, and expenses, including reasonable attorney's fees and court costs, resulting from any injury to or death of persons, or damage to property, relating to or arising from performance under this Agreement. Customer agrees to indemnify and hold GES harmless for any and all acts of its representatives and agents,

including but not limited to Customer Appointed Contractors and Installation and Dismantle Companies, any subtenant or other user of its' space or any agents or employees engaged in business on its' behalf of Customer or present at Customers' invitation.

GES to Customer: To the extent of GES's own negligence and/or willful misconduct, and subject to the limitations of liability below, GES shall defend, hold harmless and indemnify Customer from and against any claims, lawsuits, demands, liability, costs and expenses, including reasonable attorney's fees and court costs, resulting from any injury to or death of persons, or damage to property other than Goods. GES assumes no liability for bodily injury resulting from Customer's presence in areas which have been marked as "off limits to exhibitors" and during hours and days when exhibitors are present in the facility, prior to the start of and after the conclusion of their space lease with show management.

V. No liability for consequential damages. UNDER NO CIRCUMSTANCES WILL ANY PARTY BE LIABLE FOR SPECIAL, INCIDENTAL, CONSEQUENTIAL OR PUNITIVE DAMAGES, INCLUDING BUT NOT LIMITED TO LOSS OF PROFITS OR INCOME.

VI. GES Liability for Loss or Damage to Goods

Negligence standard: GES shall be liable, subject to the limitations contained herein, for loss or damage to Goods only if such loss or damage is caused by the direct negligence or willful misconduct of GES.

Condition of Goods: GES shall not be liable for damage, loss, or delay to uncrated freight, freight improperly packed, glass breakage or concealed damage. GES shall not be liable for ordinary wear and tear in handling of Goods or for damage to shrink wrapped Goods. All Goods should be able to withstand handling by heavy equipment, including but not limited to forklifts, cranes, or dollies. It is the Customers' responsibility to ensure that Goods are packaged correctly prior to shipment or movement on or off the Show floor.

Receipt of Goods: GES shall not be liable for Goods received without receipts, freight bills, or specified unit counts on receipts or freight bills. Such Goods shall be delivered to booth without the guarantee of piece count or condition.

Force Majeure: GES shall not be liable for loss or damage that results from Acts of God, weather conditions, act or default of Customer, shipper, or the owner of the Goods, inherent nature of the Goods, public enemy, public authority, labour disputes, and acts of terrorism or war.

Cold Storage: Goods requiring cold storage are stored at Customer's own risk. GES assumes no liability or responsibility for Cold Storage.

Accessible Storage: GES assumes no liability for loss or damage to Goods while in Accessible Storage. Storage charges are for the use of space and are not a form of insurance, or a guarantee of security.

Unattended Goods: GES assumes no liability for loss or damage to unattended Goods received at Show Site at any time from the point of receipt of inbound Goods until the loading of the outbound Goods, including the entire term of the respective show or exhibition. Customer is responsible for insuring its' own Good for any and all risk of loss.

Labour: GES assumes no liability for loss, damage, or bodily injury arising out of Customer's supervision of GES provided labour. If GES supervises labour for a fee, GES shall be liable only for actions or claims arising out of its' negligent supervision. If Customer elects to use unsupervised labour, then Customer assumes all liability for the actions or claims that arise out of such work, and shall provide GES and show management with an indemnity, including defense costs, for any claims that result from Customers' supervision or failure to supervise assigned labour.

Empty Storage: GES assumes no liability for loss or damage to Goods or crates, or the contents therein, while containers are in storage. It is the Customer's sole responsibility to affix the appropriate labels available at the GES Service Desk for empty container storage. Damage that is the direct result of GES's negligence shall be subject to the limitations of liability set forth in this document.

Forced Freight: GES shall not be liable for Goods not picked up by Customer's chosen carrier by the show deadline. It is the Customer's responsibility to complete accurate paperwork for shipping and ensure its' Goods are appropriately labeled. Customer acknowledges that it is a lessee of space, and as such has an obligation to remove its' Goods on or before the targeted time. If Goods remain on the floor after this point, GES has the right to remove them in order to restore the premises to its original condition for show management pursuant to the venue's lease with show management. In such cases GES is authorized to proceed in the manner chosen Customer on the Order for Material Handling Services/ Straight Bill of Lading. Failure to select on of the provided options will result in re-routing at GES's discretion, and at Customer's expense assuming the Goods are labeled for return. GES retains the right to dispose of Goods left on the show floor without liability if left unattended, left without labels or not correctly labeled.

Concealed Damage: GES shall not be liable for concealed loss or damage, uncrated Goods, or improperly package or labeled Goods.

Unattended Booth: GES shall not be liable for any loss or damage occurring while Goods are unattended in Customer's booth at any time, including, but not limited to, the time the Goods are delivered to the dock until the time the Goods are received by Customer's chosen carrier. All Material Handling Forms and/or Straight Bills of Lading covering outgoing Goods submitted to GES will be checked at the time of pickup from the booth and corrections to the count or condition will be documented where discrepancies exist.

Measure of Damage: GES's liability shall be limited to the lesser of 1) the depreciated value of Goods, 2) repair cost, or 3) the limitation of liability. The limitation of liability shall be \$0.30 (thirty cents) per pound per piece, \$50 (fifty dollars) per article or \$1000.00 (one thousand dollars) per shipment.

No Insurance: GES is not an insurance company and does not offer or provide insurance. It is the obligation of Customer to ensure Goods are insured at all times. Loss or theft of the Goods in storage or in transit to and from the show and or while on the show floor is the sole responsibility of Customer, unless it is shown that GES performed in a manner that constitutes gross negligence in the performance of its services for Customer.

Notice of loss or damage: In order to have a valid claim, notice of loss or damage to Goods must be given to GES within 24 hours of occurrence or delivery of Goods, whichever is later.

Filing of Claim: Any claim for loss or damage to Goods must be in writing, containing facts sufficient to identify the Goods, asserting liability for alleged loss or damage, and making claim for the payment of a specified or determinable amount of money. Such claim must be filed with the appropriate party within the time limits specified below. Damage Reports, incident reports, inspection reports, notations of shortage or damage on freight bills or other documents, do not constitute filing of a claim.

Claim for goods alleged to be lost, stolen or damaged at the Show Site must be received in writing by GES within sixty (60) days after the close of the show.

Claims for Goods alleged to be lost or damaged during transit must be received by the responsible party within nine (9) months of the date of delivery of Goods. GES Logistics subcontracts the movement of Goods to third party carriers. Claims for damage in transit should be made directly with the Customer's carrier as shown on the Material Handling form / Straight Bill of Lading. In the event of a dispute with GES, Customer will not withhold payment or any amount due GES for Services as an offset against the amount of the alleged loss or damage. Customer agrees to pay GES prior to the close of the show for all such charges and further agrees that any claim Customer may have against GES shall be pursued independently by Customer as a separate action to be resolved on its own merits. GES reserves the right to pursue collection on amounts owed after show close, without regard to any amount alleged to be owed for damage, or loss.

Filing of Suit: Any action at law regarding loss or damage to Goods must be filed within one (1) years of the date of declination of any part of a claim.

VII. Jurisdiction, Choice of Forum.

This Agreement shall be governed by and construed in accordance with the applicable laws of Canada or, alternatively, and depending on jurisdiction, the laws of the Province of Alberta.

VIII. Advance Warehousing / Temporary Storage / Long Term Storage.

All terms and conditions relative to Advanced Warehousing / Temporary Storage / Long Term Storage are contained in the separate agreement entitled "Storage Agreement". In the event that a Storage Agreement is not executed between the parties, the following shall apply with respect to GES's liability for Customer's Goods:

The responsibility of GES with respect to Exhibit Material is limited to the exercise of ordinary care and diligence in handling and storing of Customer's Goods. GES shall be liable only for loss or damage to Goods caused by GES's sole negligence. GES's liability is limited to sixty (\$0.60) cents per pound or the actual cash value per article. In the case of partial loss or damage, the maximum liability shall be prorated based on weight. GES is not responsible for any loss or damage to Goods caused by, but not limited to fire, theft, the elements, vandalism, moisture, vermin, mechanical breakdown or failure, freezing or changes in temperature, as well as any other causes beyond GES's immediate control. GES is not responsible for the marring, scratching, or breakage of glass or other fragile items. GES is not liable for the mechanical functions of instruments or appliances even if such articles are packed or unpacked by GES. In no event shall GES be liable for special, incidental, indirect, or consequential damages, including business loss of any kind, resulting from any damage to or loss of Goods or from any act or failure to act. Customer pays storage fees, if any or costs for advance warehousing for use of the space only. There is no guarantee of security or representations made by GES as to appropriateness of the conditions for Exhibitors' Material. This risk of loss remains the Customer's alone and GES recommends the Customer carry and maintain insurance in amounts sufficient to cover its risk.

SPECIAL NOTE: THE CONSIGNMENT OR DELIVERY OF A SHIPMENT TO GES OR ITS SUBCONTRACTORS BY A CUSTOMER OR BY ANY SHIPPER ON BEHALF OF THE CUSTOMER SHALL BE CONSTRUED AS AN ACCEPTANCE BY SUCH EXHIBITOR (AND/OR OTHER SHIPPER) OF THE TERMS AND CONDITIONS SET FORTH IN THIS AGREEMENT.