

DIGITAL FILE SUBMISSION GUIDE

Graphics

- Avoid setting type in Photoshop - instead use a vector-based program (such as Adobe Illustrator or InDesign) for your type. If you do use vector smart objects, save the file as an .eps or .psd to retain vector properties.
- If you plan to add effects to your type (such as drop shadows or glows), follow these steps:
 - a - Import the Illustrator type into Photoshop*
 - b - Add effects to the type*
 - c - Separate the effects onto a layer*
 - d - Delete the type layer*
 - e - Assemble the type and photo in a vector program.*
- Always provide logos in a vector format.
- If you have critical PMS colors to match, provide us with a layered Photoshop file to allow for color editing.
- Use gradients carefully and sparingly. Gradients often "band," and little can be done to correct the problem. Look at your high res file at 100% if you can see the banding, it WILL appear in the print. Adding 1 pt. of noise to the file may resolve the problem.

Suitable Programs for images or logos:

- Adobe Illustrator CC 2020 - .ai, .pdf, .eps
- Adobe InDesign CC 2020 - .indd, .pdf
- Adobe Photoshop CC 2020 - .pdf, .tiff, .jpeg
- Adobe Acrobat

Color

If your Vector artwork needs to be color specific, please set up your files using the Pantone color pallet. Some Pantone colors are more likely to be achieved than others, we will match all Pantone colors to the best possible interpretation. We do our best to match any physical print sample, however, the colors may deviate slightly due to the limitations within the print process.



If providing colors as CMYK, please set colors as spot. **Spot Colors** are colors that have been specifically labeled within design software so that RIP Stations can recognize them. Setting colors to "Spot" enables the RIP Station to adjust the colors independently of the design software to maximize work flow.

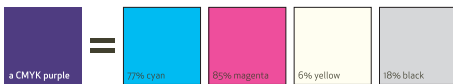

Text

Turn all fonts to outlines or convert to paths before sending the files. If you are using a program where this is not an option, YOU MUST INCLUDE ALL FONTS with your files. OTF (open type fonts) are preferred.

Editable Text



Outlined Text - preferred*



Artwork

Vector Artwork

For the best quality, create graphics in vector format (AI, EPS). Logos taken from websites are generally GIF files, and those are not acceptable as they will not print clearly. Artwork produced for contour cut decals, such as solid company logos or text, must be supplied in a vector format (AI or vector EPS). Artwork created in a pixel format (TIF, JPG) is not compatible with equipment.

preferred* AI/EPS (vector)



GIF, TIFF, JPEG (raster)



Bitmap/Raster Artwork

TIF, JPEG, PDF and PSD - These are the preferred file formats for raster images. Files should be supplied at 100dpi at full production size, or they should scale to those dimensions. If the resolution is lower than 100dpi at full production size, images can look blurry or pixelated when printed. If there is a lot of small text in the raster image, the file can be provided at higher resolutions to ensure print quality. Files obtained from the internet (JPG, GIF, PNG) or artwork created in MS Office applications (Word, Excel, PowerPoint, etc.) are often **not** suitable for high quality output for large/grand sized graphics or signage.

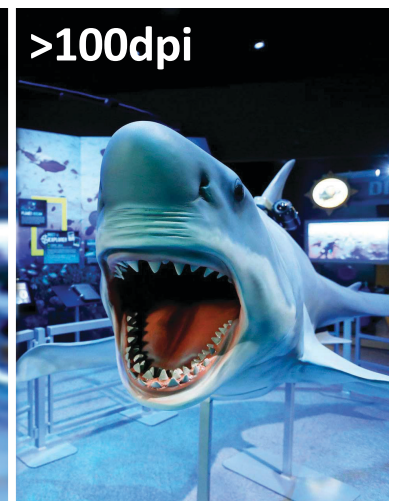

Final Print package should contain:

- Consistent color pallets in all files (if providing colors as CMYK, please set colors as spot)
 - All fonts converted to outlines and/or the fonts used
 - Embedded images and/or linked images
 - Final art at 100ppi at 100% scale (or an accurate aspect ratio with supporting resolution)
- Mandatory ZIP compression

DIGITAL FILE SUBMISSION GUIDE

Standard Signage Information

Visual Openings

- Freestanding 1/2 Meter Panel: 24" x 78"
(Bottom 6" of sign not visible because of base)
- Freestanding Meter panel: 38" x 78"
(Bottom 6" of sign not visible because of base)
- GEM Meter: 37" x 85"
(If you plan on filling the "flowerbox" with flowers, please adjust the artwork to have nothing important on the bottom 1/4 portion of the sign.)

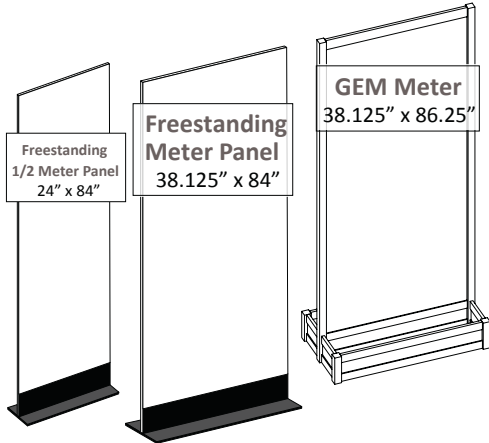

Visual Openings

- 22" x 27.5" with Easel: 22" x 27.5"
- 22" x 27.5" with Chrome sign Holder: 20" x 26"

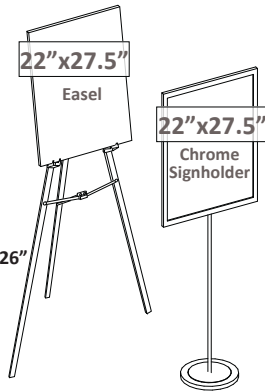

Registration Counter Information

Registration Counters

Option #1 - Vertical Header

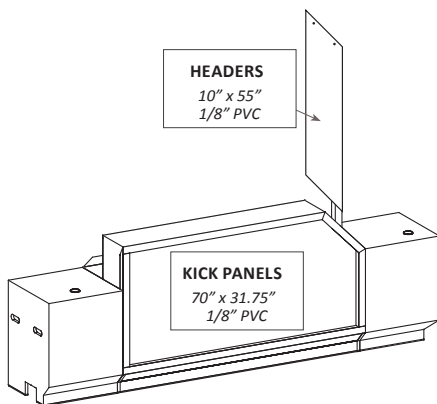

Option #2 - Horizontal Header

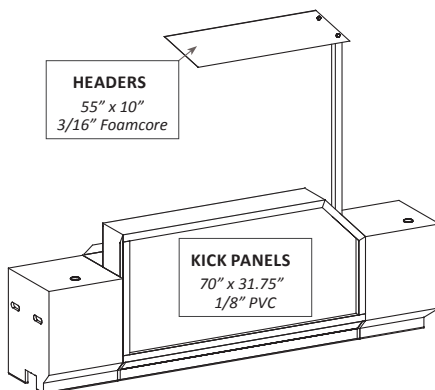

Vinyl Banner Information

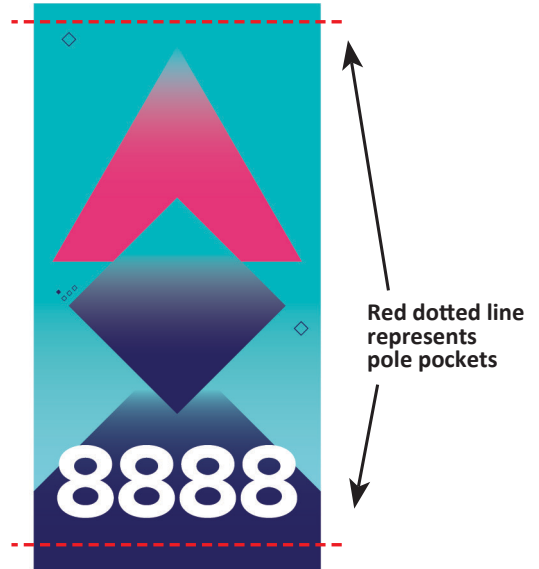

Banner Specifications and Guidelines

- 4" pole pockets are standard
- Please avoid logos & text in pole pockets
- Other finishing: Velcro, Grommets & re-enforced stitching

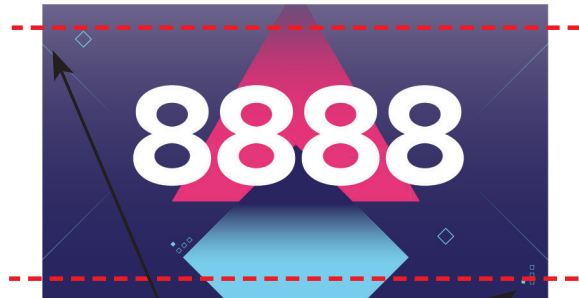

Final Print package should contain:

- Consistent color pallets in all files
(if providing colors as CMYK, please set colors as spot)
- All fonts converted to outlines and/or the fonts used
- Embedded images and/or linked images
- Final art at 100ppi at 100% scale
(or an accurate aspect ratio with supporting resolution)
Mandatory ZIP compression