

Exhibitor Services Manual Table of Contents

All orders are governed by the GES Payment Policy and GES Terms & Conditions of Contract as specified in this Exhibitor Services Manual.

Natural Products Expo East / All Things Organic™ BioFach America
 Baltimore Convention Center
 September 13 - 15, 2018

GES Information and Order Forms	4
Welcome Letter	5
Show Information	8
Show Information	8
Critical Dates Checklist	11
How to Navigate the ESK	12
How to Save Money	16
Product Showcase	19
LIFO Booths	20
Inbound Outbound Targeted Freight	21
Tips for New Exhibitors	26
Sustainability Program	28
Sustainability Booth Options	29
Required Forms	30
Payment and Credit Card Charge Authorization	30
Domestic Third Party Billing Request	31
International 3rd Party Billing Request	32
Regulations and Guidelines	33
Show Regulations and Guidelines	33
Booth Regulations and Guidelines	43
Convention Center Regulations and Guidelines	57
Certificate of Insurance Instructions	59
Fire Regulation Information	60
Show Site Work Rules	61
Stop. Think. Safety.	62
General Information	63
GES Terms and Conditions of Contract	64
Operation of All Mechanical Lifts	67
Booth Furnishings	68
Carpet Brochure	68
Carpet Order Form	69
Carpet Package Order Form	70
Standard Furniture Brochure	71
Furniture & Accessories Order Form	73
Furniture Package Order Form	76
Sneeze Guard Order Form	77
Specialty Furniture Brochure	78
Specialty Furniture Order Form	89
Convenience Package Order Form	96
Standard Exhibit Systems Brochure	98

083600172

080118

Exhibitor Services Manual Table of Contents

All orders are governed by the GES Payment Policy and GES Terms & Conditions of Contract as specified in this Exhibitor Services Manual.

Natural Products Expo East / All Things Organic™ BioFach America
 Baltimore Convention Center
 September 13 - 15, 2018

Standard Exhibit Systems Order Form	103
Booth ID Sign Order Form	105
Digital File Preparation	106
Graphics & Signage Order Form	108
Standard Graphics Brochure	109
Shipping, Drayage and Material Handling	110
Hand Carry/Cartload and Privately Owned Vehicle Services	110
Material Handling/Drayage Information	113
GES Transportation Plus	116
Material Handling/Drayage Order Form	117
Special Handling Brochure	119
Advance Shipping Labels	120
Direct Shipping Labels	121
Targeted Move-in and Freight Information	122
Target Maps	123
Clean Floor Policy	124
Pre-Printed Bill of Lading (BOL) / Outbound Labels Request	125
Freight Service Questionnaire	126
Marshaling Yard & Direct Deliveries Information	127
Cartload Service Order Form	129
Vehicle Placement Order Form	130
Show Site Storage Order Form	131
Refrigeration and Frozen Storage	133
Instructions for Cold Storage Warehouse Shipping and Delivery	133
Refrigerated and Frozen Storage Order Form	134
Cold Storage Labor/Delivery Order Form	136
Cold Storage Delivery Schedule	137
Refrigerated Product Shipping Label	138
Frozen Product Shipping Label	139
Non-Refrigerated Product Shipping Label	140
Do Not Refrigerate Shipping Label	141
Cleaning, Labor and Equipment	142
Cleaning and Porter Service Order Form	142
Installation and Dismantling Order Form	144
Forklift Order Form	146
Hanging Sign Labor Information	148
Hanging Sign Labor Order Form	149
Booth Layout - Hanging Signs	152
Hanging Sign Shipping Labels	153
Truss, Chain Hoist and Floodlight Order Form	154
Exhibitor Appointed Contractors (EACs) and Third Parties	156

063600172

080118

Exhibitor Services Manual Table of Contents

All orders are governed by the GES Payment Policy and GES Terms & Conditions of Contract as specified in this Exhibitor Services Manual.

Natural Products Expo East / All Things Organic™ BioFach America
Baltimore Convention Center
September 13 - 15, 2018

Notice of Intent to Use EAC and Policies and Procedures	156
Agreement and Rules and Regulations between GES and EAC	157
Certificate of Liability Insurance Sample	159
GES Payment Policy	160
Utilities	161
Electrical & Plumbing Services (EDLEN)	161
Internet and Telephone Services	173
Additional Official Vendor Order Forms	174
Audio Visual	174
Sampling Guidelines	176
Booth Security	185
Floral Order Form	187
Insurance	191
Lead Retrieval/Badge Scanner	192
Lowe Refrigeration Catalog & Order Form	195
Booth Staff	257
Index	260

083600172

080118

One Place for Exhibit Planning Ordering and Management

ExpressoSM by GES is a simple to navigate, picture-driven system customized specifically for your show.

It's more than just your exhibitor manual online.

Exhibitors can:

- Order exhibit products and services for multiple booths
- View account order history
- View important show and event information
- Track small packages and inbound shipments
- Download the show schedule into Outlook or iCalendar
- Print shipping labels
- Chat with our award-winning GES National ServicerSM

Order Everything You Need for Your Show



- Go to <https://e.ges.com/083600172/esm>
- Log in or sign up with a new account
- Browse products and services and you will be guided through the ordering process

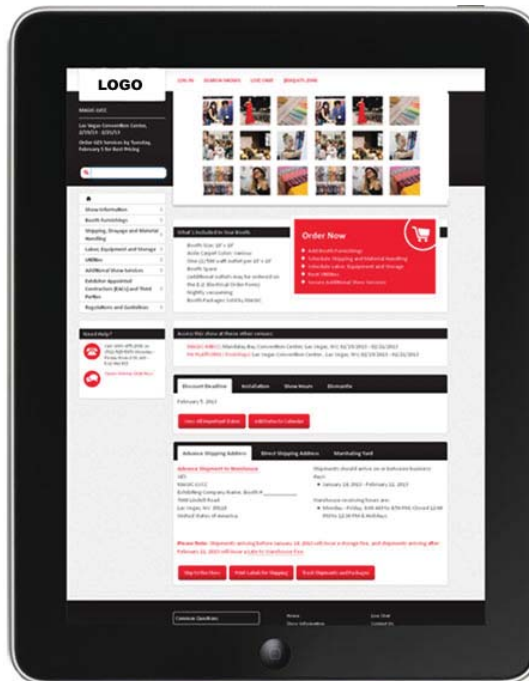



Education and Events
September 13–16, 2018
Trade Show:
Baltimore Convention Center
September 14–16, 2018
Baltimore, MD, USA

Dear Exhibitor,

Thank you for participating at **Natural Products Expo East 2018**. We would like to introduce ourselves as your Client Services Specialists. We are here to help you plan a successful show and answer any questions you may have. Please take a few minutes to read this Exhibitor Services Kit (ESK) carefully as many things have changed this year.

New for 2018:

- **BOOTH RULES & REGULATIONS** – many changes have been made this year that affects all booth types. Please be aware that the **NEW [Booth Rules & Regulations](#) will be strictly enforced.**
- **CARPET/FLOORING** - **ALL booths** are **required** to have floor covering/carpet (except for 5ft x 10ft booths).
- **BOOTH APPROVAL FORM** - **ALL booths will be required to submit** drawings/pictures with measurements for approval by **July 31, 2018**. See the [Booth Rules and Regulations](#) for more details.
- **ALL LEVEL 300 & 400 BOOTHS** – ALL booths must ship to the Advance Warehouse for Move-In.
- **TARGETED FREIGHT - INBOUND AND OUTBOUND** – **ALL** freight including [Hand Carry and Cartload Service](#) has a Targeted Move-In, Installation and Targeted Move-Out. See the [Target Floorplans](#) for details by [CLICKING HERE](#).
- **REFRIGERATED/FROZEN STORAGE** – **No Cold/Frozen Product Will Be Accepted If Shipped to The Onsite Address and Will Be Redirected at Exhibitors Expense.** Please review the [Instructions for Refrigerated/Frozen Storage Warehouse, Shipping & Delivery](#).
- **HAND CARRY/CARTLOAD & PRIVATE OWNED VEHICLE SERVICES (POV)** - If you are transporting your materials to the show yourself, please carefully review the [Hand Carry / Cartload & Private Owned Vehicle Services \(POV\)](#) section for more information. Hand Carry & Cartload **have weight limits for move-in.**

Show Information:

- All inbound exhibit material and equipment is specifically targeted for delivery by booth number. Please refer to your [Assigned Move-In Information & Target Floor Plans](#) for your scheduled date and time. **We encourage you to utilize the Advance Warehouse for shipping.** If you complete the [Freight Service Questionnaire](#) by August 20, 2018, GES will email you your assigned inbound time & date.

Exhibit Hall Hours

Baltimore Convention Center

<u>Date & Time</u>	<u>Level 300 & 400 Hot Products Pavilions</u>	<u>Exhibit Halls A-H (Booths 80 – 3962)</u>
Thursday, September 13	9:30AM – 6:00PM	10:00AM – 6:00PM
Friday, September 14	9:30AM – 6:00PM	10:00AM – 6:00PM
Saturday, September 15	9:30AM – 4:00PM	10:00AM – 4:00PM

Booths must be show ready by: Wednesday, September 12th, at 5:00pm. This applies to all booths except those moving in on Thursday morning (Last-In First-Out booths).

Exhibitors with booths on **Level 300 & 400** are required to **ship all freight to the Advance Warehouse**. Please refer to your [Assigned Move-In Information & Target Floorplan](#) for your Installation Start Time & Date.

Official Vendors and Ordering Information:

Natural Products Expo East has partnered with several service providers to offer you everything you need to have a successful show. All services and/or furnishings should be ordered in advance to save you money and ensure a timely move in. The Discount Deadline for these services is August 20, 2018.

Hotel & Travel Information:

onPeak is the official housing partner for Natural Products Expo East. Booking within the official housing block will provide the best rates at official hotels. You can reach onPeak at 1-800-388-8812 or [online](#). Please be advised that onPeak is the ONLY housing company authorized to use the Natural Products Expo East name and/or logo and it is the only company allowed to represent itself as a Natural Products Expo East housing partner.

Shipping Information:

Expo East 2018 is a **Targeted Move-In, Installation and Targeted Move-Out** trade show. All exhibitors are encouraged to ship in advance to the GES warehouse to avoid onsite wait times. If you are shipping to or unloading at show site, please follow the assigned target move-in schedule for items to arrive onsite. Failure to adhere to your assigned time will result in off-target charges and fees. Check the target floorplans prior to shipping for any updates. Please be aware that all Cold/Frozen Product ships to an offsite warehouse. *If you would like to be notified when your freight is delivered to your booth onsite, sign up for Notification at:* <https://ordering.ges.com/083600172/notifications>.

Exhibiting Tips:

Whether this is your first show or your 100th, we have put together some helpful tips to maximize your ROI at the show. These can be found in the [How to Save Money](#) and [How to Navigate the ESK](#) sections of the ESK.

Environmental Responsibility:

Exhibitions and events, by their very nature, create waste and for that reason Natural Products Expo East is proud to continue our Sustainability Program. We recognize our trade show has an impact on the environment and through our Sustainability Program we are striving to identify, understand, and address these impacts. Exhibits should strive to utilize recycled, renewable and use energy efficient materials whenever possible. More information and the Exhibitor Sustainability Guide can be found here. This year GES

offers Recycle and Compost Porter Services. For more information and to order Porter Services, please go to: <https://ordering.ges.com/083600172/porter>.

If you have any questions, please do not hesitate to contact us.

Sincerely,
JP, Sarah and Jill

[JP Potenziani](#) | Client Services Specialist
AZ, CA, NM, NV, UT

[Sarah Quinlan](#) | Client Services Specialist
Africa, Asia, Australia, Canada, Europe, Latin America, Middle East, New Zealand, South America
CO, CT, MA, ME, NH, NJ, NY, PA, RI, VT

[Jill Ramar](#) | Client Services Specialist
AK, AL, AR, DE, FL, GA, HI, IA, ID, IL, IN, KS, KY, LA, MD, MI, MN, MO, MS, MT, NC, ND, NE, OH, OK, OR, SC, SD,
TN, TX, VA, WA, WI, WV, WY

Natural Products Expo East 2018
p.866-458-4935 | expoeast@newhope.com



All orders are governed by the GES Payment Policy and GES Terms & Conditions of Contract as specified in this Exhibitor Services Manual.

Natural Products Expo East / All Things Organic™ BioFach America
Baltimore Convention Center
September 13 - 15, 2018

Harvest Festival: Wednesday, Sept 12: 2:00pm - 6:00pm

Questions?



- Chat with us <http://www.ges.com/chat>
- Contact us online: <https://e.ges.com/083600172/contactus/esm>

Official Service Provider

Global Experience Specialists, Inc. (GES) Phone (in USA): (800) 475-2098 International Calls: (702) 515-5970
 7000 Lindell Road FAX (in USA): (866) 329-1437 International Faxes: (702) 263-1520
 Las Vegas, NV 89118-4702

GES will be onsite to assist you in coordinating any last minute services, order additional products, and to answer any questions you may have.

Show Information

Natural Products East

Standard Booth Size: 10' x 10' Deep
 8' Backwall Drape: Natural Muslin
 3' Side Wall Drape: Natural Muslin
 Aisle Carpet Color: Safari

Booth Carpet is not included but is required

Standard Booth Size: 5' x 10' Deep
 8' Backwall Drape: Natural Muslin
 3' Side Wall Drape: Natural Muslin
 Aisle Carpet Color: Safari

5x10 Booths - Carpet is included with their booths

Note: Orders Placed On-Site Within 90 Minutes Of Show Opening Will Be Delivered After The Show Opens. Cold Storage Shipments: No cold storage shipments will be accepted at the direct to show site address. Cold/ Frozen shipments must go to the Advance Cold warehouse.

Discount Deadline Date

Monday, August 20 GES orders must be received with payment by this date.

Exhibitor Move In

Sunday,	September 9	8:00 AM - 4:30 PM	Reference Target Move-In Schedule
Monday,	September 10	8:00 AM - 4:30 PM	Reference Target Move-In Schedule
Tuesday,	September 11	8:00 AM - 4:30 PM	Reference Target Move-In Schedule
Wednesday,	September 12	8:00 AM - 4:30 PM	Reference Target Move-In Schedule
Thursday,	September 13	7:00 AM - 9:00 AM	*ALL EXHIBITOR BOOTHS MUST BE SHOW READY BY 9AM*

Clean Floor Policy

Tuesday, September 11 5:00 PM Crates for booths 400 square feet and larger must be empty and labeled for removal. - For more info see Clean Floor Policy

Wednesday, September 12 12:00 PM Crates for booths 300 square feet and smaller

G-1 041918 Cstmhc 080118 083600172



Show Hours

Thursday,	September 13	10:00 AM -	6:00 PM	*Level 300 & 400 open at 9:30am
Friday,	September 14	10:00 AM -	6:00 PM	*Level 300 & 400 open at 9:30am
Saturday,	September 15	10:00 AM -	4:00 PM	*Level 300 & 400 open at 9:30am

Exhibitor Move Out

Saturday,	September 15	4:00 PM -	10:00 PM	Reference Target Move-Out Schedule
Sunday,	September 16	8:00 AM -	4:30 PM	Reference Target Move-Out Schedule
Monday,	September 17	8:00 AM -	12:00 PM	Reference Target Move-Out Schedule

Please take notice - this event moves out on overtime, all applicable surcharges will apply.

If Carrier is picking up freight for multiple booths, please be aware that you will not be able to pick up your freight until ALL BOOTHS ARE READY FOR PICK-UP. We advise that you confirm with your client that their booths are packed and ready to ship before you arrive in the Marshaling Yard to avoid unnecessary delays and costs.

Empty Container Return

Saturday, September 15 5:30 PM Start time for Empty Container Return.

Carrier Check-in Post-Show

Saturday,	September 15	2:00 PM	Reference Target Move-Out Schedule
Sunday,	September 16	8:00 AM	Reference Target Move-Out Schedule
Monday,	September 17	8:00 AM	Reference Target Move-Out Schedule
Tuesday,	September 18	8:00 AM	Reference Target Move-Out Schedule

Facility Clear

Monday, September 17 12:00 PM All exhibitor materials must be removed.

Shipping Addresses: Use provided Shipping Labels in this Exhibitor Services Manual to expedite handling

Advance Shipments to Warehouse:

c/o GES
Natural Products Expo East / All Things Organic™
BioFach America
(Your Company Name & Booth Number)
UPS Freight
6571 Washington Blvd.
Elkridge, MD 21075
USA

Shipments should arrive on or between:

August 7 - September 5, 2018
Hours for receiving are Monday - Friday, 8:00 AM - 4:30 PM
The GES Advance Warehouse will be closed Monday, September 3, 2018, in observance of the Labor Day holiday.
For Exhibitor set up date and times, please refer to the "Exhibitor Setup Date & Time" on the Target Move-In Floor Plan:
<https://e.ges.com/083600172/targetmovein/esm>

Please Note: Shipments arriving before Tuesday, August 7, 2018 will incur a storage fee, and shipments arriving after Wednesday, September 5, 2018 will incur a Late to Warehouse Fee.

Direct Shipments to Show Site:

c/o GES
Natural Products Expo East / All Things Organic™
BioFach America
(Your Company Name & Booth Number)
Baltimore Convention Center
One West Pratt Street
Baltimore, MD 21201
USA

Shipments should arrive on:

Reference Targeted Floorplan for Dates & Times.

Please Note: Anything arriving off target may be turned away or charged an off target surcharge, please check the target freight floorplan.

*Carriers Must Check-In at the Marshaling Yard.

Marshaling Yard Site Address:

c/o GES
Natural Products Expo East / All Things Organic™
BioFach America
(Your Company Name & Booth Number)
TA Plaza
5501 O'Donnell Street
Baltimore, MD 21224
USA

Shipments should arrive on or between:

September 8 - 13, 2018
Check in hours are 6:00 AM - 2:00 PM

Cold Storage Advance Shipments:

c/o GES
Natural Products Expo East / All Things Organic™
BioFach America
(Your Company Name & Booth Number)
4801 Hollins Ferry Rd.
Suite B
Halethorpe, MD 21227
USA

Shipments should arrive on or between:

September 10 - 12, 2018
Hours for cold storage receiving are:
Monday - Tuesday, 8:00 AM - 4:00 PM
Wednesday, 8:00 AM - 12:00 PM

*Deliver to loading dock located at rear of building.

Cartload Service (Privately Owned Vehicles) must check in at the marshaling yard:

M&T Bank Stadium in Lot O
701 W Ostend St.
(Southwest corner at the intersection of Ostend and Ridgley)
Baltimore, MD 21224-4629
USA

September 10 - 12, 2018
Reference Targeted Floor Plan for POV unloading times.

If you have Hand Carry/Cartload or POV (Privately Owned Vehicles), please click here for more instructions regarding loading and unloading:

<https://e.ges.com/083600172/povmarshalingyard/esm>

Critical Dates Checklist for EXPO EAST 2018

As Soon as Possible		Information Requested by:
	Read Exhibitor Service Kit (ESK) in its entirety	GES
	Review Marketing and Promotional Opportunities	New Hope
	Make Hotel Reservations through Official Vendor	onPeak
	Secure Meeting Room Space (contact your Account Manager for availability)	New Hope
	Make Airline/Rental Car Reservations	Exhibitor
	Create show packets and finalize schedules for your staff (refer to Exhibitor Tips for guidance) Include phone numbers, emergency meeting place, show info etc	Exhibitor
	Enter FREE listing promoting a demo, book signing or presentation in your booth. Use the Exhibitor Hosted Events form	New Hope
	Log In to Update Show Directory Company Listing	New Hope
July		
7/31/2018	Booth Approval form must be submitted for ALL Booths, regardless of booth type, by 7/31/18. Include booth diagrams or pictures and measurements	New Hope
August		
8/1/2018	Print deadline for Show Directory --includes company name and booth number, ad reservations, artwork, etc. Log In to update	New Hope
8/7/18 - 09/5/18	Ship your Hanging Sign to the Advance Warehouse (if applicable)	GES
8/7/2018	First day for Advance Freight shipments at the warehouse	GES
8/7/2018	Verify ALL travel arrangements prior to leaving for the show	Exhibitor
8/9/2018	Pricing increases for additional exhibitor badges ordered over allotment	New Hope
8/20/2019	Submit Exhibitor Appointed Contractor (EAC) form	GES
8/20/2018	Order lead retrieval unit; advance deadline	CompuSystems
8/20/2018	Order Security for booth	DTA
8/20/2018	Deadline to order Booth Furnishings: Carpet, Furniture & Accessories, Graphics, Cleaning	GES
8/20/2018	Order Column Wrap for booth (if applicable)	GES
8/20/2018	Order Electrical Service	Edlen
8/20/2018	Secure onsite storage (dry)	GES
8/20/2018	Secure onsite cold storage (frozen/refrigerated)	GES
8/20/2018	Order any food preparation, catering, and labor for booth	Centerplate
8/20/2018	Discount date to order internet & cable connections	PSAV
8/20/2018	Order Refrigeration Display Equipment (no refunds after this date)	Lowe
8/20/2018	Audio Visual Equipment Order Discount Deadline	PSAV
8/20/2018	Order Hanging Sign Rigging, Labor and Equipment (if applicable)	GES
8/20/2018	REQUIRED - If sampling products refer to the regulations at https://ordering.ges.com/083600172/catering . Products that you do not manufacture or distribute must submit a Catering Menu/Sampling Guides form to CenterPlate. (i.e. condiments or buns added to the sample, etc.)	Centerplate
8/27/2018	Register Booth Personnel for Badges (suggest that Badges are ordered no later than 8/27/18)	New Hope
September		
9/1/2018	Confirm date and time of onsite booth space selection for 2020 (see the Exhibitor Resign Appointment tab in your Exhibitor Console - if you have not already booked space)	New Hope
9/5/2018	Last day for Advance Freight shipments to arrive at warehouse without surcharges - all Carriers must check in by 2:00pm	GES
9/5/2018	Last day for Hanging Signs to arrive at the Advance Warehouse - all Carriers must check in by 2:00pm	GES
9/9/18 - 9/13/18	Ship NON-Perishable Freight Direct to Baltimore Convention Center (must arrive on Target Move-In Date and Time) NOTE: ALL LEVEL 300 AND 400 FREIGHT MUST SHIP TO THE ADVANCE WAREHOUSE - CANNOT SHIP DIRECT TO SHOW SITE	GES
9/10/18 - 9/12/18	Ship Perishable Freight to the Cold Storage Warehouse (DO NOT ship to the convention center or it will be re-directed at exhibitor's expense)	Exhibitor
9/11/2018	Clean Floor Policy - all crates for booths 400 square feet and larger must be tagged and removed from show floor by 5:00pm	Exhibitor
9/12/2018	Clean Floor Policy - all crates for booths 300 square feet and smaller must be tagged and removed from show floor by 12:00pm	Exhibitor
Onsite	Make sure to have all tracking information for freight sent to showsite (just in case)	Exhibitor
Onsite	Attend events and education to enhance exhibiting experience and networking opportunities	Exhibitor
Onsite	Review invoices and verify costs for general contractor, electrical and other vendors	Exhibitor

The Exhibitor Service Kit Reference Guide

While coordinating an exhibition may seem like a daunting task, this document will help you navigate and explain what is in the **Exhibitor Services Kit**, help you with move in and move out procedures, and give you the framework for putting together a successful show.

How to Navigate the Exhibitor Services Kit:

The **Exhibitor Services Kit**, also known as the **ESK**, is your guide to ordering items for your booth, shipping your materials to the show, and viewing rules & regulations. Here is a section by section summary of how to navigate the ESK.

ESK Homepage:

The ESK homepage provides information on booth inclusions, quick links to important and frequently used items, important dates and deadlines, as well as links to order forms for all official vendors.

Show Information:

The Show Information tab is the starting point for all basic show specific information. Be sure to read through the **Welcome Letter** and **Important Dates & Deadlines** in this section as a starting point to planning.

- The Important Dates and Deadlines is a one stop shop for all the discount deadlines in a handy organized page.
- Need to register for badges or secure a hotel room? Links are available on the ESK Home Page!

Regulations & Guidelines:

The Regulations & Guidelines tab includes all show polices, booth regulations, venue regulations, and safety information. It is critical to read this section in its entirety prior to planning your Exhibit to ensure a successful experience.

- **Show Regulations & Guidelines** include general rules & regulations of the entire exhibition. You can find regulations on animals, age restrictions, rules about booth activities and events, sound level rules, photography/videography rules, and much more.
- **Booth Regulations & Guidelines** will tell you what you can and cannot do when building and designing your booth structure and layout. If you want to know how high your booth structure can go, how tall your sign can be, whether or not you are allowed to have a hanging sign, etc.
- **Fire Rules & Regulations** are different for each facility. It is important to know regulations concerning usage of items such as open flames, cooking devices, hazardous materials, and compresses gasses as well as flame retardant requirements for your booth materials. You will need to follow both show fire regulations and facility regulations. You will find them under the **Regulations & Guidelines** tab under Fire Regulations.
- **Union Rules** also must be observed concerning moving your booth materials in yourself, when you are required to hire labor for installation and dismantling your booth, and when electrical or forklift labor are required and can be found under the Show Site Work Rules/Union Jurisdiction Regulations.

Booth Furnishings & Accessories:

Most shows require some sort of floor covering. Be sure to check the ESK Homepage under 'What's Included in a Standard Booth' for show requirements. If flooring is required, you can provide your own or rent carpet from GES through this tab. You can also order carpet, tables and chairs, as well as other accessories such as wastebaskets and shelving.

- Booth Packages can save you time and money by combining items for a reduced rate.

Graphics & Signage can be ordered as well as shell schemes and hard wall booths.

Inbound & Outbound Targeted Freight:

This section contains **Inbound & Outbound Targeted Freight** information that is critical for a successful show site experience.

- Shows with **Targeted Freight** have assigned move in times for each exhibitor. It is critical that each exhibitor know their target time and date to save money. You will find your target inbound information under the **Target Floorplan** tab.
- Shipments received off target will be assessed an off-target fee that is a percentage of your total material handling charge for the shipment.
- Be sure to read the **Inbound & Outbound Targeted Freight** document while planning your shipping to and from show site. These documents contain information that can save time and money during the planning process.

Hand Carry/Cartload & Privately-Owned Vehicle (POV) Services:

This section contains information on how to move-in your materials if you plan on bringing them in yourself with your personal vehicle. It describes the differences between hand carry and cartload services and instructions of where/how to unload.

- Information on when and where to unload your materials at the show site
- Cartload Service order forms

Instructions on how the **Hand Carry/Cartload/Privately Owned Vehicle** process works

Shipping, Drayage, Material Handling & Access Storage:

Use this section of the ESK to place orders for material handling, print shipping labels and view general information regarding material handling.

- Be sure to fill out the **Freight Service Questionnaire** if you are planning to ship any freight to the event. This form lets GES know what materials to expect and will allow them to better assist you with your shipping needs.
- Pre-print your address labels' using the **Print Shipping Labels** tab to ensure all your freight is shipped to the correct booth space.
- Get a shipping quote. Shipping through GES can save you time and money.
- Create a pre-printed outbound **Bill of Lading** to speed up the move-out process by selecting the **Pre-Printed Bill of Lading (BOL) & Outbound Labels Request** form. Be sure to also review the **Sample Outbound Bill of Lading with Instructions** for tips on how to fill out the form.

Refrigerated & Frozen Storage:

This section contains information on how to ship your refrigerated or frozen products to the show site.

- Instructions on how the **Refrigerated & Frozen Warehouse Shipping** process works and when you need to ship your cold product. **NOTE:** *you may be shipping to a location other than the Convention Center – see Refrigerated & Frozen Storage shipping labels.*
- If you need storage for your cold product during the event, you will find the ordering forms under the **Refrigerated & Frozen Storage** tab. You will order space by the cubic foot by completing the **Refrigerated & Frozen Storage Order Form** located under **Refrigerated/Frozen Storage Order Forms, Delivery Schedule & Shipping Labels**.
- If you have your cold product in storage and need to arrange to have it delivered to your booth, you will need to complete the **Refrigerated & Frozen Order Form, Cold Storage Labor/Delivery Order Form** and the **Cold Storage Delivery Schedule**.
- If you need to ship your cold product to the show site, there are separate **Shipping Labels** also located under the **Refrigerated & Frozen Storage** tab.

Labor/Equipment, Hanging Sign & Rigging:

Using this tab, you can place orders for hanging signs and aerial rigging, order union labor and equipment, submit your layout for sign placement, and access a link to your **Booth Approval Form**.

- All hanging signs *must* be approved by show management. GES will not hang any signs that have not been approved. Be sure to fill out the **Booth Approval Form** located in your **Exhibitor Console** prior to placing your orders.

- All hanging signs must be shipped to the Advance Warehouse prior to the event by deadline, located in the Hanging Sign - Advance Warehouse Shipping Labels tab
- Be sure to review **Booth Regulations & Guidelines** before ordering a hanging signs, as not all exhibit space types are permitted to have them.
- When preparing for the event you may discover the need to hire union labor for the installation and dismantling of your booth. Pricing and options for hiring labor can be found here.

Cleaning, Vacuuming & Porter Service:

Vacuuming, carpet cleaning, floor waxing, and porter service including trash removal and wiping down of counters must be ordered. If you are sampling in your booth, we highly recommend porter service. Keep in mind that waste baskets will NOT be emptied throughout the day without ordering porter service.

Utilities:

This section includes order forms for Utilities such as **Electrical, Internet/Telephone/Cable/ & Plumbing**

- If you need to plug-in a computer, lead retrieval unit, cell phone, lights for your display, a machine, or a showcase you will need to order electrical. Even if an outlet is placed behind your booth onsite, you must place an order to power the outlet. To figure out how much power to order, you can add up the total “Amps” on the tags of each item, or if you give the designated electrical provider a call, they can help you with figuring out how much power will be needed for the items.
- **Ordering Electrical Labor** is only needed if you need a power drop located in a specific area of the booth (other than the back wall) or distributed under the carpet. Please note that any cords and supplies used during Labor will be added to your bill based on usage.
- **Plumbing** can also be ordered under the Utilities tab if needed for your booth. For safety and liability, the specified contractor must handle these services.

Additional Show Services:

This section includes all other vendors outside of the general contractor.

- **Lead Retrieval/Badge Scanner** allows you to capture leads generated at the show electronically as opposed to gathering business cards by hand and risk misplacing them.
- **Catering Menu/Sampling Guidelines** is where you can order food and beverages for your booth, review the sampling guidelines and find the contact information for any catering questions you may have.
- **Security/Booth Monitoring** is personalized in booth security above and beyond the perimeter security provided for the show.
- **Floral Arrangements** can help to spice up your display but be sure all arrangements abide by booth height regulations.
- **Liability Insurance** is required for all exhibitors. You may use your own carrier or our recommended vendor. All International exhibitors are automatically enrolled for U.S. Insurance with ExhibitorInsurance.com
- **Temporary Booth Staff** can assist by working your booth during show floor hours. Exhibitor badges will be required for all temporary booth staff.
- **Lowes Refrigeration Catalog & Order Form** if your product requires refrigeration or frozen storage you can review what is available and place an order.

Exhibitor Appointed Contractors (EACs) & Third Parties:

If you are hiring another company outside of the ones that we have included in the **Exhibitor Services Kit** (to help set-up your booth or deliver special equipment to your booth) that requires access to a booth during installation and dismantling, you will need to complete the information within this section.

- This is a **2-step process:**
 - The exhibiting company needs to fill out the **Notice of Intent to Hire an EAC Form and the Agreement, Rules & Regulations between GES & EAC Form**

- The company you have hired (EAC) will need to submit a valid **Certificate of Insurance** to the general contractor.

How to Save Money When Exhibiting

With so many rules, regulations, deadlines and vendors, planning for any tradeshow can be expensive. We understand that this can be one of the most frustrating parts of planning, and have compiled a list of tips to help you save money.

Save on Shipping:

- **Packages:** Consolidate your packages, don't ship multiple small boxes to an event. They could get separated during transit and arrive on separate days causing additional charges, material handling fees, and set up delays. Remember, there is a minimum material handling fee for each shipment that is received.
- **Electronic Literature:** Attendees often throw away literature rather than take it home. Both shipping and printing these materials can be very expensive. Instead, order the Lead Retrieval device through your Exhibitor Services Kit, scan the attendee badge and email them the information they have requested. Another great option is to load the information on a USB drive that can be given to attendees. It is a great marketing tool, and is less likely to be thrown out.
- **Shipping Documentation:** Often materials are lost or damaged during shipping. Be sure to document all the materials you ship and their condition at the time they leave your possession, and bring tracking information with you on-site.
- **Tradeshow Shipments:** The best way to ensure that shipments will arrive on-time and to the correct venue is to ship with a carrier who knows the ins and outs of tradeshow shipping. Communicate your move-in dates to your carrier as well as marshalling yard information, if applicable.
- **Know Your Carrier:** Have contact information for your carrier readily available, including weekend contact information. Do not leave the convention center until you have confirmation that the carrier has checked in at the marshalling yard during move-out.
- **Insurance:** Make sure the insurance on the shipment covers freight from the time it leaves your possession to the time it returns home.
- **Advanced Warehouse:** It is important to do a cost analysis when deciding whether to ship to the advanced warehouse or direct to show site. Important factors include: the cost of material handling, the cost of your freight carrier waiting in the marshaling yard, the cost of storage you are paying to hold your materials 30 days pre-event (storage is included in the advanced warehouse rate), and the impact the loss of the shipment may have if lost or delayed in transit. Shipping to the advanced warehouse gives you peace of mind that your shipments will be in your booth when you arrive.
- **Special Handling Charges:** Be sure to read the special handling brochure under the Shipping, Drayage, Material Handling and Access Storage tab of the Exhibitor Services Kit, a special handling charges can add up quickly.
- **Cartload Service:** Cartload service is a type of material handling where you can bring your equipment to show site in your vehicle and have it offloaded and delivered to your booth. If you will be driving to the event, rather than shipping your materials and paying for material handling, pre-order the cartload service and bring your materials with you to the event. Be sure to read the Move-In Info page located in the move-in section of your

Exhibitor Services Kit for specific Cartload Service information for the event. **Cartload Service** limited to a total shipment weight of 600lbs.

- **Bill of Lading:** Be sure to fill out your Bill of Lading correctly and turn into the **GES Service Center**. The bill of lading (BOL) tells GES that your shipment is ready to be picked up at your booth and delivered to your carrier. Do not leave the completed form in your booth, it must be turned in at the GES Service Center for processing. Be sure to fill out all information correctly and pay special attention to the section regarding shipping in the event your carrier does not pick up the shipment. Select the “Use GES logistics” option for the least expensive option. Returning shipments to the Warehouse is extremely expensive. Make sure the contact phone number is legible on all copies of the bill of lading.

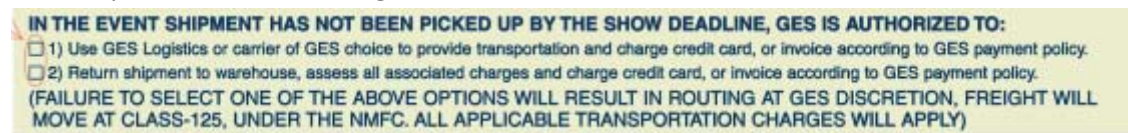

- **UPS and FedEx:** When shipping with UPS or FedEx never leave shipments on the show floor, more than likely they will end up being shipped via the alternative method you selected on your BOL, and this will cost you more money. UPS and FedEx have unpredictable timelines that are not recommended for tradeshow planning. If using these options take the boxes to the local offices for processing. There is often an office in the convention center or nearby hotel.
- **Move-Out:** Move-out takes time. Depending on the size of the show it could be hours before crates for your booth are returned, and there is no way to tell how long it will take. Schedule your flights far enough out to ensure you have enough time to successfully move out. Scheduling flights too soon could result in missed flights or paying GES to pack and ship your booth materials for you. Reference the Target Move-Out schedule for your carrier check-in time.

Save on Show Orders:

- **GES Service Center:** If you are unsure what to order or which forms to fill out, call the GES Service Center. Submitting the incorrect forms can be costly and result in orders needing to be placed on site. Avoid this by asking questions. GES will be happy to guide you to the correct forms to save you time and money. Don't forget to ask your GES representative what booth packages are available. These packages are designed to save you money.
- **Booth Rules & Regulations:** It is extremely important to read the rules and regulations for each show that you attend. Booths that are out of regulation will be required to make adjustments on site, which can be very costly. These adjustments could include ordering furnishings, removing portions of your booth, or omitting key marketing structures. Do not assume that because it worked last year, it will work this year. If you have any questions on the booth rules and regulations contact your Client Services Specialist. Their contact information can be found in the Exhibitor Services Kit Welcome Letter.
- **Discount Deadlines:** Most vendors have an early bird discount deadline. If you order early you will often save a substantial amount of money on your booth orders and equipment. Discount deadlines can be found in the Critical Dates Checklist under the Show Information tab of the Exhibitor Services Kit.

- **Overtime Labor Charges:** All labor before 8:00 am and after 4:30 pm Monday thru Friday, and all hours Saturday, Sunday and holidays, will be overtime. Straight time rates are for hours worked between 8:00 am and 4:30 pm Monday thru Friday, excluding holidays.
- **Booth Inclusions:** Be sure you know what is included with your booth space. Most events do not have any included furnishings in the booth space, so be sure to check the Exhibitor Services Kit for what is included and place orders accordingly. Orders placed onsite are very expensive.
- **Flooring:** Flooring is **mandatory** for most events. You can often save money on flooring by renting through GES. The cost to purchase flooring, ship it, and have it installed is often more expensive than renting through GES. This of course greatly depends on the flooring you require. If you prefer to purchase carpet be mindful of the color. White carpet may only last one event while dark or patterned colors will last much longer. Lastly, remember that carpeting is not the only option when deciding on booth flooring. Carpet tiles are often an affordable solution that are light weight and easy to transport.
- **Booth Cleaning:** Be sure to pre-order cleaning, vacuuming and porter service for your booth. These services are not included in the booth rental or trash can ordering and will be more expensive if purchased on-site.
- **Booth Security:** Tradeshow are not secure spaces. While show management has perimeter security for the hall, they are not watching individual booths. Items that are stolen are often never recovered. Do not store expensive items in your booth and be sure to order booth security if you will be leaving items of value in the booth overnight.



Education and Events: September 12–15, 2018
Trade Show: September 13–15, 2018
Baltimore Convention Center, Baltimore, MD USA

LOGISTICS & SPECIFICATIONS: Product Showcase

Thank you for purchasing a Product Showcase at Natural Products Expo East. In order to meet the deadlines and specifications for this opportunity, please read the following information in its entirety. If you have any questions, contact your Client Service Specialist at the contact information listed at the bottom.

Locations:

- **Pratt Street Level 300:** Bulk & Food Service, Frozen/Refrigerated, Gluten Free, Grocery, Herbs/Medicinals, Kosher, Organic (certified), Other.
- **Charles Street Level 100:** Lifestyle & Vitamin/Supplements.

Product Showcase Unit Sizes:

- **All Categories** (except Bulk and Food Service Category): Half of a Shelf 18”H X 18”W X 11”D
- **Bulk and Food Service Category:** Half of a Shelf 30”H X 18”W X 11”D

Set-Up: Exhibitors will be able to enter the Showcases at the below times only. NO EXCEPTIONS.

	Wednesday, 9/12	Thursday, 9/13	Friday, 9/14	Saturday, 9/15
Set-Up	10:00am - 5:30pm			
Showcases Unlocked for Adjustments		8:30am - 9:30am 12:00pm - 1:00pm 5:30pm - 6:30pm	8:30am – 9:30am 12:00pm – 1:00pm	8:30am – 9:30am
Product Removal				4:00pm – 5:30pm

Guidelines:

- Bring any supplies (tape, scissors, stapler, markers, etc.) you may need to set-up your display. We do not keep supplies in the Product Showcase Office.
- Product displays *cannot exceed 20lbs* in weight, anything above will bend and/or break the shelf.
- Electricity is not provided or allowed in the showcases. Battery operated lights or moving display objects are welcome.
- Showcases are assigned alphabetically within your category based on "EXHIBITING AS" name and **CANNOT** be changed.
- **DO NOT TAMPER WITH OTHER PRODUCTS. Tampering will result in your product showcase being eliminated. This includes moving name tags.**

Security:

We advise that you utilize empty bottles & packages for displays. Although we make every effort to secure the Product Showcase area, New Hope is not liable for any lost or damaged goods while in display area.

Removal:

Remove your products from the showcase between 4:00 pm and 5:30 pm on Saturday, September 15, 2018. **Please plan accordingly.** All products left in the showcase at 5:30 pm will be donated.

To Purchase Onsite Visit:

Product Showcase Office in the Pratt Street Lobby Level 300.

Questions? Contact us!:

Client Service Specialist (p) 303.998.9208 (e) expoeast@newhope.com



Definitions and Guidelines for Last In, First Out (LIFO) Booths

LIFO booths are generally set near loading dock doors or main freight aisles where heavy traffic for show move-in is high. These aisles need to be clear during move-in per fire marshal rules and regulations. These booths are required to setup and dismantle in a short timeframe, these booths are required to be a quick setup and not a structure that takes a lot of time to assemble.

Recommended:

Booth Setup:

- Having a simple booth display and able to set up in 30 minutes or less.
- Order all vendor services in advance.

Freight:

- Shipping your freight advanced or making sure your freight arrives no later than your [setup hours](#).
- Make sure all freight has empty labels and ready to go by 9:30am the morning of the start of the show. This helps ensure that the show floor can open on time.
- Keeping all freight out of the aisles.
- 500lbs or less of freight.
- Deliveries will not be accepted one hour before the show.

LIFO Rules and Regulations:

- Cannot move in before the hours stated in your Booth Agreement.
- No hardware booths or complicated booth displays – no tools needed to assemble, one person can assemble and set up booth within 30 minutes.
- No plumping allowed.
- Keeping freight aisles clear at all times.
- All services must be ordered in advance.
 - GES: Flooring, Electrical, tables, trash cans & chairs.
- Booth Approval from Show Management is required.
- No crates for shipment and teardown allowed.
- Exhibits must be constructed with enough space (1 foot) to allow for utility service at the rear of booth (back drape, rails, power drop).
- Hanging signs are not allowed in In-Line Booths.
- Pop-Up Tents are not allowed.
- [Front of booth](#) – no items over 4ft (1.22m) in height can be within 5ft (1.52m) of aisle (red area of diagram) as it blocks sight line.
- [Rear of booth](#) (maximum of 5ft (1.52m) from the back drape in a 10ft x 10ft (3.05m x 3.05m) booth or maximum of 4ft (1.22m) in an 8ft x 10ft booth (2.43m x 3.05m) cannot exceed 8ft 3in (2.5m) in height.
- Any signage or side wall facing the neighbor cannot have any logo or identification facing the neighboring booth. Any side wall must be finished carpentry.
- Any portion of an exhibit over 8ft 3in (2.5m) is not allowed and will have to be moved or removed.

Targeted Freight Information

****BOTH INBOUND AND OUTBOUND ARE TARGETED****

The information below contains **IMPORTANT** instructions regarding **Targeted Move-In, Installation and Targeted Move-Out at Natural Products Expo East 2018**. Even if you are planning to Hand Carry or use Cartload Service, read this document. ALL scheduled time & date move-in/out information can be found by [CLICKING HERE](#).

Please note that all booths on Level 300 & 400 must ship to the Advance Warehouse

Freight Move-In Options

Ship to the Advance Warehouse:

Advance Warehouse receiving is available between Aug. 5th and Sept. 5th, 2018.

- Ship **non-perishable** booth freight to the GES Advance warehouse. The warehouse address can be found by [CLICKING HERE](#).
- Print **Advance Shipment Labels** by [CLICKING HERE](#). Make sure to remove all old labels from crates and cartons.
- Material handling charges will apply and can be estimated by [CLICKING HERE](#).
- Booth freight will be delivered to booth by GES on assigned **Freight Unloading Target Time & Date** listed on the **Target Floorplan**. Booth setup can begin on the **Installation Start Time & Date** indicated (assigned by color) with corresponding time & date listed on the key.

Ship Direct to Show Site:

Shipping to the Baltimore Convention Center: freight MUST arrive at marshalling yard on assigned Freight Unloading Target Time & Date

- Ship booth materials via a freight carrier directly to show site. **Exhibitors on Levels 300 & 400 are not able to ship direct and must ship to the Advance Warehouse.**
- Print **Direct Shipment Labels** by [CLICKING HERE](#). Remove all old labels from crates and cartons.
- Material handling charges will apply and can be estimated by [CLICKING HERE](#).
- **Freight Unloading Target Time & Date** is located on the **Target Floorplan** indicated by the assigned color with corresponding time & date listed on the key. The Target floorplan can be found by [CLICKING HERE](#).
- Schedule the freight carrier's arrival time to match your **Freight Unloading Target Time & Date**.
Note: Carriers may check in starting at 6am on the assigned target date. Failure to do so may result in refused freight and/or additional material handling charges.
- Location and hours of the Marshaling Yard by [CLICKING HERE](#). Instructions regarding the Marshaling Yard process for carriers are located at the bottom of the page.
- Booth setup can begin on the **Installation Start Time & Date** indicated (assigned by color) with corresponding time & date listed on the key.

Privately Owned Vehicles:

ONLY Privately Owned Vehicles are allowed to order cartload service or use hand carry to unload their vehicles.

- A POV, or privately owned vehicle, is considered to be any vehicle that is primarily designed to transport passengers, not cargo or freight. Please note that these vehicles cannot have any branding and/or company logos on them to be considered a POV.

- **Examples of POVs:** Passenger vehicles under 1 ton: Small pickup trucks, passenger vans, taxis, limos, Uber, Lyft, Cars, etc.



NOT Privately Owned Vehicles (POV):

You are not a POV if you are one of the vehicle types listed below and must go directly to the Marshaling Yard before unloading.

- Company Vehicles of any kind, trailers, moving vans, U-Hauls, Cargo Vans, vehicle with a lift gate, materials on skids/pallets, crates, anything requiring freight moving equipment.

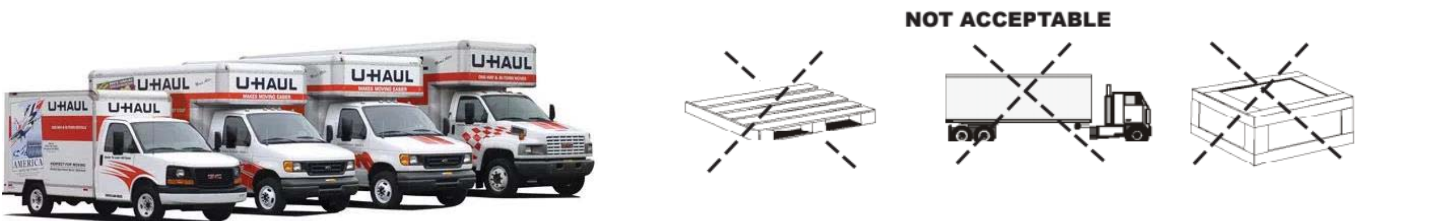

Cartload Service to Move-In & Move-Out:

To use Cartload Service:

- Must have 2 people
- Must have “loose” product (not palletized/crated)
- Total weight of items must be less than 600lbs? (Cartloads that exceed 600lbs will be charged at standard Material Handling rates.)
- Vehicle must be “acceptable” as shown above

If ALL items above apply, you may use Cartload Service! Proceed to the Marshaling Yard.

- GES can help unload a passenger vehicle. Pre-order Cartload Service by [CLICKING HERE](#) for the order form.
- Move-in may happen at/or after the targeted **Installation Start Time & Date.**
- All cartload customers **MUST** go to the GES Cartload Marshaling Yard to check in **FIRST.**
Cartload Lot O – Privately Owned Vehicles (POV) ONLY
 M&T Bank Stadium in Lot O
 701 W Ostend St. (Southwest corner at the intersection of Ostend and Ridgley)
 Baltimore, MD 21224-4629
 United States of America
- Look for “**Cartload Lot O – Privately Owned Vehicles (POV) ONLY**” signs to check in for POV/Cartload.

- Check in with a GES Representative to obtain a dock pass and directions on where to be unloaded.
- Vehicles for Cartload Service will be unloaded first come, first served as dock space is available.
- GES will direct the vehicle toward the cartload area for unloading.
- Cars may not be left unattended at any time. There must be two (2) people with the vehicle; one person to go with the product to the booth space and one person to remove the vehicle from the dock.
- Cartload service has a **20-minute** max time to unload. Privately Owned Vehicles that are left unattended will be towed away at the exhibitor's expense.
- POVs may park at local garages, after unloading at the dock and then return to the BCC for booth set-up. To find parking visit bestparking.com, select "Baltimore" and a map will pop up with garages and parking options.

Hand Carry to Move-In & Move-Out:

ONLY Privately Owned Vehicles may use Hand Carry – 100lbs max.

- Move-in may happen at/or after the targeted **Installation Start Time & Date**.
- An exhibitor can **Hand Carry** materials to the booth, provided material handling equipment is NOT used to assist moving a maximum of **100lbs** of freight. Use of hand carts, two-wheeled dollies, or any four-wheel cart or dolly is **prohibited**. Access to the loading dock or freight areas is not permitted.
- Cars may not be left unattended at any time. There must be two (2) people with the vehicle; one person to go with the product to the booth space and one person to remove the vehicle. Items unloaded curb side **cannot** be left unattended. There will be a maximum **15-minutes** to unload in the designated areas and any unattended vehicles will be towed away at the exhibitor's expense.
- Privately Owned Vehicle must be performed by a full-time employee of the exhibiting company and could be asked by the Union for proof of employment (paystub/benefits documentation).
- The use of hand trucks, pallet jacks, lift gates or any other mechanical equipment is NOT permitted by anyone other than GES employees.
- **Designated Hand Carry locations are:**
 - Sharp St. Entrance
 - Pratt and Howard St. Entrance
 - Pratt and Charles St. Entrance
- **Show Site Work Rules/Union Jurisdiction Regulations** must be abided by and can be found by [CLICKING HERE](#).

Please note that the Baltimore Convention Center is a Union Facility and Members of the Carpenters union claim jurisdiction on the operation of all material handling equipment, all unloading and reloading, and handling of empty containers. **An exhibitor may ONLY move materials that can be carried by hand, by one person in one trip, without the use of dollies, hand trucks, or other mechanical equipment.*

PERISHABLE FREIGHT MOVE-IN

All refrigerated & frozen products must be shipped to the Cold Storage Warehouse between Sept. 10th and Sept. 12th, 2018. See Shipping Labels for delivery times.

- **Instructions for Refrigerated/Frozen Storage, Warehouse, Shipping & Delivery** as well as shipping labels, labor and delivery order forms can be found by [CLICKING HERE](#). Any refrigerated & frozen product shipped to show site will be refused and rerouted at the Exhibitors Expense.
- Certified weights are required for all shipments.
- Complete the **Refrigerated & Frozen Storage** Order Forms for storage and delivery to your booth by [CLICKING HERE](#).

- Print Shipping Labels
- Order Refrigerated & Frozen Storage
- Order Refrigerated & Frozen Storage Labor & Delivery
- Set-Up Refrigerated & Frozen Storage Delivery Schedule
- Cold product will be accessible onsite beginning Wednesday evening.

Contact Mary Barnes at GES with any questions you may have regarding cold storage at mbarnes@ges.com or 650-333-0589.

FREIGHT MOVE-OUT

Expo East 2018 has a **Targeted Move-Out for all areas**. Please reference carrier check-in time & date on the **Target Move-Out Plan** by [CLICKING HERE](#). Please reference the tips below to help make your move-out run smoothly.

Pack freight once the show closes, BUT NOT BEFORE THE OFFICIAL END TIME allowing for return of packing materials. Schedule STAFF DEPARTURE TIMES accordingly:

- After the show closes on the last day of the event, dismantling and packing booth properties can begin. Early move out is not permitted, as it is disrupting for neighboring booths who are trying to do business. It is also a breach of the show contract which may result in loss of privileges for future shows or a penalty fee.
- **Schedule staff departure times to allow enough time to pack the booth.** The return of packing materials may take **over 6 hours** once aisle carpet is removed.
- Make sure to keep all items within the booth space and out of the aisle so that carpet can be rolled up. Security will be ensuring all attendees are off the show floor for safety reasons. Please keep exhibitor badges on.

Prepare freight for outbound shipment from trade show:

- Once the booth properties have been packed, make sure they are labeled for shipping, including the full address of where the shipment is going. It is also recommended to **include a cell phone # and contact name** on the label as well. This can be helpful in the event of a shipping issue.
- **Contact carrier** to verify pickup address and scheduled time. Shipping is not an automatic process. If using a carrier other than GES Logistics, ensure arrangements have been made with the carrier.

Turn in filled out OMHF/BOL to GES Service Center (regardless of carrier) - Please Do Not Leave Bill of Lading (BOL) in the booth:

- Once packed and freight is labeled, leave the freight in the booth space, and take the **Outbound Material Handling form (OMHF / BOL)**, provided by GES, to the GES Service Center. This is a five-page carbon copy form that will serve as the release to give the freight to the selected carrier, whether this is GES Logistics or an outside contracted carrier.
- Please make sure the information placed on the **OMHF/BOL** matches the carrier name and shipping destination used when the driver checks in with GES. If the information doesn't match, there may be a delay in outbound shipment being processed. **PLEASE NOTE: GES will not accept the OMHF/BOL until after the show closes.**
- The **OMHF/BOL** is a multi-page document. Make sure contact name and cell phone number are legible on every page in case any issues arise during shipping.
- **PLEASE NOTE:** Should a small package carrier, i.e. UPS, FedEx, DHL, be selected, please note that they may not pick up within the facility per move out regulations. It is highly recommended that leave these types of shipments not be left in the booth. It is suggested that they be transported to a direct drop off/pickup location, such as the business center or a hotel.

It is recommended that freight not be left unattended.

- However, should freight be left unattended, make sure to verify the pickup address and scheduled time with the carrier, as this may NOT be the address to where freight was originally shipped. All freight must be picked up at the exhibit location to avoid additional fees. Make sure the carrier knows the carrier check in time. Anything that does not have a carrier checked in for the freight will be shipped via GES Logistics or returned to the warehouse, depending on the selection on the **OMHF/BOL**.

Please contact us with additional questions or for clarification:

- **GES Service Center:** Contact GES with questions about order forms, to place an order or receive quotes for material handling or shipping. They can be reached at 1-800-842-6309.
- **Natural Products Expo East 2018 - Exhibitor Assistance:** Contact your Client Services Specialist with questions regarding Target Freight Information, Hand Carry and Cartload processes or any other general questions. To Contact your Client Services Specialist [CLICK HERE](#).

Tips for New Exhibitors

All orders are governed by the GES Payment Policy and GES Terms & Conditions of Contract as specified in this Exhibitor Services Manual.

Natural Products Expo East / All Things Organic™ BioFach America
Baltimore Convention Center
September 13 - 15, 2018

First Time Exhibitors

Exhibiting for the first time can be confusing and stressful. GES is here to make your ordering process as simple and stress free as possible. GES will be on-site at the show to assist you in coordinating any last-minute services, order additional products and answer any questions you may have. Save money by ordering early! Order by the Discount Deadline of August 20, 2018 for best pricing.

For quick and easy ordering, visit the Espresso online ordering site: <http://e.ges.com/083600172/esm>

Details Matter When Shipping

Material Handling is the unloading of your exhibit materials. The service includes delivery to your booth, handling of empty containers to and from storage and removal of your materials from your booth for reloading onto your outbound carrier. This is not to be confused with the cost to transport your exhibit material to and from the event.

- Unloading the freight and delivery to your booth is not included. Avoid unexpected costs at show site and estimate the cost for this service. <http://e.ges.com/083600172/item/200500>
- We understand that your calculation is only an estimate. Invoicing will be done from the actual weight. Adjustments will be made accordingly.
- Save by combining shipments. A minimum charge applies for each shipment under 200 lbs.
- Make sure that a Bill of Lading is filled out completely for each shipment.
- Confirm that your driver has the correct dates and times that your shipment needs to be delivered and picked up.
- Use provided shipping labels to make sure show name, booth number and other vital information is provided.

Shipping, Drayage and Material Handling: <http://e.ges.com/083600172/shippinghandling/esm>

Dot Your I's and Cross Your T's

Please be aware that a valid credit card is required for all forms of payment. We require your credit card charge authorization to be on file with GES even if you are paying by check or wire transfer.

- Make sure your credit card information is complete and correct, including the expiration date.
- Review GES Payment Policy and the Terms and Conditions of Contract.
- Clearly indicate when paying by check. All check payments should be returned to:

GES
Bank of America
P.O. Box 96174
Chicago, IL 60693

Bank ACH/wire transfer payment information

Beneficiary:	GES	If requested, following is the physical address for routing identifiers: Bank of America, Wire Transfer-Customer Services 2000 Clayton Road Concord, CA 94520 USA
c/o Bank of America	Account #: 7188101819	
901 Main Street,	Wire ABA Routing #: 026009593	
TX1-492-07-14	ACH ABA Routing #: 071000039	
Dallas, TX 75202-3714 USA	SWIFT Address: BOFAUS3N	
Telephone # (702) 263-2795 or (702) 914-5112	CHIPS Address: 0959	

For ACH/Wire Transfer send the following information to GES via email to Cash Application Team at cashapplication@ges.com.

- Exhibiting company name, show name, show facility
- Date and amount of wire transfer
- Bank and country where transfer originated

No Tipping

GES work rules prohibit the solicitation or acceptance of tips in cash, products or gifts of any kind by any employee. Our employees are paid appropriate wages denoting professional status; therefore, tipping of any kind is prohibited.

Where Did My Crates Go?

After your exhibit is set-up and your products displayed, you must place "empty" stickers on your empty containers for storage during the show. At show site a kiosk with a floor plan and color coded "empty" stickers will be available. Crews will clear the floor of all "empty" stickered containers to clear room for other freight.

- Simply write your booth number, company and show name on the sticker and place the container in the aisle. It will be stored throughout the exposition and then returned to your booth upon show close.
- Place stickers on all four (4) sides of the crate.
- Please label your empty containers as soon as possible to keep your area clear and make it easier to prepare your booth.

Don't Forget to Take Out the Trash

Exhibitors planning on disposing of booth properties and/or floor covering at the end of the show should pre-order this service. In the event that excessive booth properties and/or floor covering are abandoned/left on the floor at the conclusion of a move-out, a dumpster fee will be billed to the exhibiting company.

Keeping Up Appearances

Pay close attention to your booth size when ordering items based on booth sq. footage or quantity of decorating items. Please do not order more than what will comfortably fit in your space.

- Exhibitors that order two (2) standard pre-cut carpet pieces should keep in mind that there will be a visible seam where the pieces of carpet are placed together. GES cannot guarantee that carpet colors will be an exact match due to dye lot differences.
- Order just enough carpet to fit your standard booth space. A 10' x 10' booth should not order 10' x 20' carpet.
- We custom cut carpet to fit your needs.

It's All About the Padding

Ordering carpet for your booth? Think about the kind of padding you need if you are going to be on your feet all day. That little extra cushion can make all the difference at the end of the day.

Carpet and Padding: <http://e.ges.com/083600172/carpet/esm>

What Goes Up Must Come Down

If labor is needed for your booth space at the time of move-in, you will also need labor for move-out. Remember, what you put up must be taken down.

- See Labor Information form for rules specific to the show. Work rules can vary based on show location.
- Gratuities in any form, including cash, gifts, or labor hours for work not actually performed are prohibited by GES.
- All rates are subject to change if necessitated by increased labor and material costs.
- Pre-order labor to save.

Labor Services: <http://e.ges.com/083600172/LaborandEquipment/esm>



New Hope Network™ Sustainability Program

Natural Products Expo East, in conjunction with the Baltimore Convention Center and GES, will be coordinating donation services at NPEE 2018.

Why donate: By donating your extra exhibit material we can work together to prevent goods from going to waste, or entering landfills. Goods donated will be picked up by various local non-profit organizations.

Guidelines:

Packing: To ensure that all donation-collection companies are able to transport the contributed goods, all items must be packaged and ready for pick up **before you leave the building on September 15, 2018.** All items must be labeled.

Labels: "Donation" stickers are available at the GES ServiCenter on-site. All items left on the exhibit hall floor must be clearly labeled.

Labor: If you require labor to package your donated goods, please complete the Labor Order Form and submit to GES.

Materials: Please ensure all donated items are in good condition. Any damaged or incomplete items will be disposed of at the exhibitor's expense.

The items being collected for donation include, but are not limited to:

Building Materials	Roofing Materials	Hard Flooring	Carpet Rolls/ Carpet Tiles
Fabric	Furniture	Lumber	Glass
Empty Boxes/ Crates	Office Supplies	Books/ Magazines	Decor and Accessories

The following items will **not** be collected for donation:

- Partial items (example: a portion of a flooring display)
- Marketing materials and/or brochures (these will be recycled if possible)
- Damaged or cracked materials

DONATION SUBMISSION FORM

If you have any questions about items intended for donation, please contact us at: sustainability@newhope.com

If your company is interested in participating in this year's Donation Program, please submit this form to sustainability@newhope.com. In the event you have additional materials to donate once at show site, please visit the GES ServiCenter to fill out an updated form and **call Lindsay Arell at 303.681.1768.**

Company Name: _____ Booth Number: _____

OnSite Booth Representative: _____ Contact Number: _____

Materials Anticipated for Donation:

By signing below I hereby agree that the goods I submit for donation fall within the listed guidelines and will be properly packed and labeled by September 15, 2018.

SIGNATURE: _____ PRINT NAME: _____ DATE: _____



Eco-friendly solutions for one all-inclusive price exclusively for Natural Products Expo East / All Things Organic BioFach America

100% Recycled Components

10x10 Rental Solutions

\$5629



\$5836



10x20 Rental Solutions

\$11375



\$12237



Display Options



For more information, contact your GES Account Representative. You may also call 800.801.5180 or email advantage@ges.com.

Payment and Credit Card Charge Authorization

All orders are governed by the GES Payment Policy and GES Terms & Conditions of Contract as specified in this Exhibitor Services Manual.

Natural Products Expo East / All Things Organic™ BioFach America
 Baltimore Convention Center
 September 13 - 15, 2018

Form Deadline Date:
 August 20, 2018

Exhibiting Firm Company Name		Name of Primary Contact	Booth Number
Street Address	City, State, Zip/Country	Primary Contact Phone	Email
Phone	Fax	Name of Secondary Contact (Optional)	
Name of Contact at Booth/Show Site	Phone	Secondary Contact Phone	Email
Please indicate if you will be using a Third Party for billing of services: <input type="checkbox"/> No <input type="checkbox"/> Yes - Please return Third Party Billing Request form		GES invoice Sent to: <input type="checkbox"/> Primary Contact <input type="checkbox"/> Secondary Contact	

Payment Information

- Please complete the information and return payment in full with this form and your orders. You may choose to pay by credit card, check or bank wire transfer, however, we require your credit card charge authorization to be on file with GES.
 Only submitting your Credit Card Authorization? Do it online: <http://e.ges.com/083600172/item/2222>
- All balances must be paid at the conclusion of the event. You agree to late fees up to 1.5% per month on any balance not paid at the conclusion of the event, or balance left without appropriate credit card on file.
- For your convenience, we will use this authorization to charge your credit card for any additional amounts ordered by your representative or services rendered to your company for this event.
- GES will charge a convenience fee for each request to reprocess payment to an alternate credit card in order to cover incremental processing costs. An alternate credit card is a credit card different than the one used to process your initial payment in accordance with GES payment policy. The convenience fee will be quoted at the time your request is made to reprocess payment. The convenience fee will be added to your account balance and settled utilizing the new credit card provided.

GES requires the highest standards of integrity from all employees. Please call our confidential Always Honest Hotline at (866) 225-8230 to report fraudulent or unethical behavior.

Bank ACH/Wire Transfer Payment Information

Beneficiary: c/o Bank of America 901 Main Street, TX1-492-07-14 Dallas, TX 75202-3714 USA Telephone # (702) 263-2795 or (702) 914-5112	GES Account #: 7188101819 Wire ABA Routing #: 026009593 ACH ABA Routing #: 071000039 SWIFT Address: BOFAUS3N CHIPS Address: 0959	If requested, following is the physical address for routing identifiers: Bank of America, Wire Transfer-Customer Services 2000 Clayton Road, Concord, CA 94520 USA
---	---	--

For ACH/Wire Transfer send the following information to GES via email to Cash Application Team at cashapplication@ges.com.

- Exhibiting company name, show name, show facility, and booth number
- Date and amount of wire transfer
- Bank and country where transfer originated

Credit Card Charge Authorization (Required for All Forms of Payment)

All information must be provided. Your order will not be processed if any information is missing. We require your credit card charge authorization to be on file with GES even if you are paying by check or bank wire transfer.

Cardholder Name - Please Print			
Billing Address			
City	State	Zip/Country	
Account Number	Expiration Date	<input type="checkbox"/> MasterCard	<input type="checkbox"/> Corporate Card
		<input type="checkbox"/> VISA	<input type="checkbox"/> Personal Card
		<input type="checkbox"/> American Express	
I agree in placing this order that I have accepted GES Payment Policy and GES Terms & Conditions of Contract, including authorization for GES to retain personal information to better serve my need for GES services at future events.			
Please Sign	X	Check Number	MM/DD/YY
Cardholder Signature	_____	Total Check Payment	Check Dated
Cardholder Name - Please Print	_____	Total Credit Card Payment	\$
	Date		\$

Review and Return

Credit Card Payments Return to Fax: (866) 329-1437 • International Fax: (702) 263-1520
 Check Payments Return to GES • Bank of America P.O. Box 96174, Chicago, IL 60693



083600172

080118 110317

Show Regulations and Guidelines

Americans with Disabilities:

All exhibiting companies are required to be in compliance with the Americans with Disabilities Act (ADA), and are encouraged to be sensitive, and as reasonably accommodating as possible, to attendees with disabilities. Information regarding ADA compliance is available from the U.S. Department of Justice ADA Information Line, (800) 514-0301, and from the ADA Web site at www.ada.gov.

Animals:

Animals are not allowed at the Show except for service animals (dogs).

Announcements:

Announcements are only made for lost children. Lost and found is available at the Show Office. We encourage attendees, if separated from their group, to designate the Show Office as the location to meet.

Badge Access/Age Restrictions:

All exhibitors must have their badges before they will be allowed onto the Show floor. No one under the age of 18 will be allowed on the Show floor during set up and break down hours.

Balloons:

Please refer to applicable convention center policies at <https://ordering.ges.com/083600172/convcenterregs>.

Booth Activity/ Events, Meetings & Seminars:

- Demonstrations are part of the exhibit program involving the interaction of exhibit personnel and their audience through corporate presentations, product demonstrations or sampling. All live demonstrations should be documented and submitted to Show Management.
- Live demonstrations consist of presentations/activities such as live music, dancers, special guest appearances, comedian acts, etc. as well as any type of activity, other than daily product sampling, which may attract a large crowd and higher noise levels. If you plan to have this type of activity in your booth, please complete the Exhibitor Hosted Events Form on our website. You will need to go to Exhibitor Login to complete the form so we can monitor for crowd control and noise levels.
- Booth activity, including sales presentations, product demonstrations, entertainment, celebrity appearances, etc., must be confined within the exhibitor space contracted for so as not to interfere with traffic flow in the aisles or encroach into neighboring exhibits. Sampling or demonstration tables must be placed at a minimum of 3ft (.914m) inside your booth. Exhibitors must contract sufficient space in order to comply with this rule.
- Should spectators or samplers interfere with the normal traffic flow in the aisle or overflow into neighboring exhibits, Show Management will have no alternative but

to request that the presentation or sampling be eliminated. Intent: The aisles are the property of the entire Show, and each exhibitor has the responsibility to ensure proper flow of traffic through the entire Show. Aisles must not be obstructed at any time.

- Exhibitors must regulate their own booths to be sure the noise level from demonstrations or sound systems is kept to a minimum and does not interfere with other exhibitors and attendees conducting business.
- Show Management reserves the right to determine at what point sound constitutes interference with others and must be discontinued. Sound levels may not be higher than 85 decibels measured from a minimum of ten feet away.
- All product demonstrations involving any moving and potentially hazardous machines, displays or parts must have hazard barriers to prevent accidental injury to spectators. Demonstrations must always be supervised by exhibitor personnel who can stop the demonstration in an emergency. All demonstrations involving potentially hazardous by-products, such as dust, fumes, sparks or flames, must be approved in writing by Show Management prior to the Show. Demonstrations must be set back at least 3ft (.914m) from the aisles.
- Events, seminars and meetings must be registered and approved by using the Exhibitor Hosted Events Form, which can be found by going to the Exhibitor Login page. Meetings, events and seminars not designated or organized as a part of the Show are not permitted during Show floor hours. Exhibitors have the option to publish their meeting or events online in the Hosted Events listing or indicate on the form that it is a private event. If it is indicated as a private event, it will not be listed online.

Company promotion, sampling and literature distribution by exhibitors must be done within their contracted exhibit space, with the exception of designated sponsorships and event marketing opportunities for which exhibitors have contracted with Show Management. Violation of this policy can result in expulsion from future shows.

At the close of the Show, exhibitors can donate their remaining product to the local food bank or authorize attendees to take the product with them. If an exhibitor would like to authorize an attendee to take a large quantity of product samples that exceeds more than one sample bag, the exhibitor and attendee must visit the GES Service Center prior to the close of the Show floor. GES will provide further instructions to the attendee on pick-up location and time.

Carpet/Floor Covering Requirements:

- Management provides carpet for the uncarpeted floors to enhance the overall appearance of the show floor.
- The exhibitor is required to provide carpet or floor covering to cover its contracted exhibit space including areas that already have facility carpeting. You may bring your own floor covering or order it through the official show decorator, GES. All booths without floor covering at 5:00 pm on the night before Show open or they will be carpeted by GES at the exhibitor's expense.

Character of Exhibits:

- It is the exhibitor's responsibility to create an attractive display area.
- Show Management reserves the right to approve the character of the display and to prohibit any display which, because of noise or other objectionable features, detracts from the general character of the Show. Exhibits must be in good taste as determined by Show Management.

Competing Events:

Show Management reserves the right to control all suites and meeting rooms in the official hotels, which are participating in housing for the Show. Exhibitors shall not have hospitality suites and/or meeting rooms during Show hours or during a time that conflicts with official functions of the Show and shall not host any event during the Show or official functions. Marketing and sales activities are limited to the Show floor during Show hours.

Compressed Gases:

See fire rules and regulations at <https://ordering.ges.com/083600172/fireregs>.

Cooking Regulations/Product Sampling:

- Dishwashing and food prep cleaning: dishwashing, utensil cleaning and food dumping is not permitted in the restrooms. Dishwashing stations are provided to assist with these needs.
- Each exhibitor that is sampling food or beverages must add the exclusive caterer of the convention center as additionally insured. Fire and health regulations are strictly enforced. The exhibit hall will be regularly inspected by fire marshals and representatives from the health department. Please review the following guidelines for exhibiting. Operation of any cooking appliance, e.g., ovens, stoves, barbecues, hot plates, deep fryers, etc., and all demonstrations using these appliances must be isolated away from the public or be protected on the front and sides with a clear plastic or Plexiglas shield.

The shield must be:

- A minimum of 1/4" thick
- 3-sided
- A minimum of 18" high or at least 6" higher than the cooking appliance

- Exhibitors that manufacture or distribute food and beverages may sample these products to attendees. Exhibitors are prohibited from sampling products they do not manufacture or distribute. For example, if you make or distribute veggie burgers, you may not add condiments or buns to the sample.
- Exhibitors that do not manufacture or distribute food and beverage products, but wish to distribute these items to attendees, must go through the exclusive caterer of the convention center.

General Conditions applicable to Food/Non-Alcoholic Beverage Samples:

- Items dispensed are limited to products manufactured, processed or distributed by exhibiting firm.
- Non-alcoholic beverages are limited to a maximum of 8oz. servings.
- Food items are limited to 4oz servings. Full size products will be permitted if the exhibiting firm is the manufacturer, distributor and/or supplier of the specific product only, and it is given out in its original package. For example: If your product is deli turkey meat or beef product, you may give out a full size sample in its original package, but you will not be permitted to give out a full size sandwich or full size hamburger.
- Any exhibiting firm wishing to give out samples that include additional ingredients not distributed and/or manufactured by it are required to purchase these items through the exclusive caterer of the convention center.
- Food and/or beverage items such as traffic promoters (e.g., popcorn, coffee, bar service) MUST be purchased through the exclusive caterer of the convention center.

General Conditions applicable to Alcohol Samples:

- No alcoholic beverages may be brought onto the premises from an outside source.
- All alcoholic beverages being sampled must be ordered through exclusive venue caterer.
*All alcohol that will be sampled must be purchased by the exclusive caterer of the convention center and then resold to the exhibiting firm that is licensed to sample the alcoholic product (even if the exhibiting firm is the manufacturer or distributor of the product).
- No person under the age of 21 will be served alcoholic beverages. Samples are to only be served to persons 21 years of age or older. Each booth must provide a visible sign, stating: *"Guests must be 21 years of age to participate in sampling of alcoholic beverages. Picture I.D. is required."*
- All alcoholic beverages must be served by an exclusive caterer of the convention center certified bartender(s).
- Show Management reserves the right to refuse alcoholic beverage service to anyone who appears to be intoxicated or underage.
- No alcoholic beverage may be removed from the premises.
- All alcohol items are limited to the manufacturer of the product only.
- Items dispensed are limited to products manufactured, processed or distributed by exhibiting firm and must be directly related to the purpose of the Show.
- Standard fee for storage, handling, delivery, etc. will be charged if applicable.

Tips for Sampling

- For cost-effective sampling, only distribute samples to customers and prospects who have entered your booth to discuss your product.
- Sampling further inside of the booth encourages attendees to stop in and speak with you.
- Sampling at the edge of your booth encourages attendees to taste and keep walking.
- An appropriate sample size is typically a bite or drink. After attendees express interest, offer a larger sample.

How many samples do I need?

- Determine the number of product demos one person can make in an hour
- Multiply that by the number of hours of the Show (e.g., 12 hours)
- Multiply the results by the number of sales staff in the booth
- Review the final numbers with your staff

Dismantling:

Exhibitors will not be permitted to dismantle their exhibits or do any packing prior to Show close. **This policy will be strictly enforced.**

Electrical Equipment :

Please refer to GES and venue policies at

<https://ordering.ges.com/083600172/convcenterregs>.

Exhibitor Appointed Contractors:

Please refer to GES for details at <https://ordering.ges.com/083600172/officalserv>.

Federal Tax ID (Penton will not give out its tax ID):

Please be advised that under no circumstances will **Informa (formerly known as Penton)**, **GES** or the convention center provide their Federal Tax Identification numbers for international shipments entering the United States. It is the responsibility of the exhibitor to engage the services of a freight forwarding company/customs broker that can help facilitate the proper clearance of its exhibit material. This includes shipments entering the United States over the borders using the exhibitor's company-owned or privately owned vehicles.

For your convenience, we have secured the services of **GES Logistics** to assist with clearance of goods through customs. Please contact-GESLogistic_International@ges.com.

Fire Laws:

Please read and understand the *fire regulations* located under Regulations and Guidelines in the online ESK - <https://ordering.ges.com/083600172/fireregs>. All materials used in exhibit construction, decoration or as a temporary cover must be certified flame retardant. A sample must be available for fire marshal testing. Crates, packing material and wooden boxes may not be stored in or behind exhibit booths.

Good Neighbor Policy/Noise & Sound Levels:

- Floor manager desks will be located throughout the Show floor in case you have any immediate issues needing attention. Floor managers and floor manager assistants will be available to supervise and coordinate various exhibitor, facility and contractor activities and to assist in a management capacity on the Show floor as directed by Show Management.
- All audio and video should be appropriate for a general audience. In the event of a complaint from any person on a booth's content, Show Management will investigate and determine if the content is offensive or inappropriate. If content is determined to be offensive or inappropriate, the exhibitor must cease use of such content.
- Island Booth Exhibitors: In the spirit of neighborly cooperation, we ask you to avoid adding any unnecessary walls or drapes that may contribute to obstructed views of exhibitors that surround your booth. Feedback from our attendees indicates that this causes substantial frustration in their ability to navigate the Show floor.
- Please take your exhibiting neighbors into consideration when positioning hanging signs and exhibit structures that could impede or obstruct lines of sight to them. Your thoughtful planning will make the Show a better experience for yourself, attendees navigating around the halls and other exhibitors.
- Sound and noise are permitted up to a maximum of 85 decibels. Show Management reserves the right to require any group whose noise levels disturb another group within the building to reduce their sound to a reasonable level that does not disturb any other group. If you feel that your event will have high noise levels at any time (including bands, loud music for dancing, shouting, singing, or other noise), please make arrangements with your Account Manager and Show Management to ensure that no other group will be in the vicinity of your event.
- Show Management will intervene, if necessary, and reserves the right to shut down exhibits deemed objectionable. Floor managers in each show location will rove through the exhibit areas monitoring the decibel level during Show hours. Measurements will be taken at a distance no greater than 10' from the offending display. After measuring a continuous decibel level of greater than 85 dB, following a complaint being registered by a spectator, a neighboring exhibitor or personal observation by a roving designee, disciplinary action may be taken.

Health Department Regulations:

Food may not be served from a "common bowl" unless tongs are used to distribute the food. We suggest compostable single-serve cups, toothpicks and single napkins.

Even if gloves are used, a hand-washing kit is still required. The sole use of a waterless hand sanitizer is not in compliance with health department regulations.

All perishable foods such as milk, fish, eggs and poultry products must be temperature controlled. Cold foods must be kept at or below 41° F (refrigerated or on ice). Hot foods must be maintained above 135° F.

All vendors who wish to sample their product must provide protection of open food sampling (e.g., unpackaged crackers, chips, dips, drinks, etc.). All unpackaged foods on display must be protected with a sneeze guard shield or plastic covering that is rigid, semi-permanent, and

provides adequate protection that follows the Temporary Food Facility Guidelines. All food samples should display a label with its common name and ingredients.

Tip: Per the health department's advice, you may be asked to cease sampling operation at your booth if you do not meet the above requirements. Sneeze guard protection has been required for the protection of open food sampling. This health code is strictly enforced if violated.

You may contact GES to obtain a sneeze guard at <https://ordering.ges.com/083600172/sneeze-guard>.

Personal Care Product Applications

- Sterilized utensils must be used. A fresh, sterilized cotton ball, spatula, Q-tip or powder puff must be used for each individual application. These utensils may not be reused.
- When applying lip applications of any kind, eye shadows, face blushes, etc., a portion of the product must be scraped off with a utensil and applied to the individual with the utensil. The used utensil may not be returned to the pallet. A new, sterilized utensil must be used for each application.
- When using products that are packaged in a container other than a squeeze-type container, such as a jar, a sterilized utensil must be used to remove the product from the container. Once the product has been applied to the individual, you may not return the used utensil to the product (i.e., no double-dipping).

Insurance/Liability:

Liability insurance, property insurance and worker's compensation insurance must be taken out by each exhibitor at its own expense and must comply with state laws. Insurance can be obtained by the exhibitor's insurance company. A rider to existing policies may be taken out providing complete protection for the period of the Show, from move-in to move-out. If you need assistance acquiring insurance, ExhibitorInsurance is our official Show insurance vendor.

Music Licensing:

It is the responsibility of the exhibitor to pay all royalties, license fees, or other charges due to any person or entity for any music or other entertainment played within the exhibitor's contracted space. Exhibitor must obtain music performance rights licenses through ASCAP and/or BMI (and any other necessary performing rights associations) if exhibitor intends to use copyrighted music in its booth.

Moving Displays/Lighting:

Lighting instruments must be focused so as not to interfere with adjacent exhibits.

Special Effects:

Fog, smoke, pyrotechnics, bubbles/snow/confetti and other special effects, are strictly prohibited on the tradeshow floor or meeting rooms.

Onsite Sales/Charitable Donations:

No direct/retail selling is permitted on the Show floor. Attendees may place orders with exhibitors for products/services at the Show, but the product or service ordered/purchased must be delivered to the attendee after the close of the Show. No soliciting of attendees shall be permitted in the aisles or in other exhibitors' booths. Signs showing the prices of items must not be displayed.

Don't let your leftover product go to waste at the end of the Show. You can use it to help those local residents who are struggling in poverty. Not only are you helping people in the area, but you can also save yourself the shipping expense of sending your leftovers back to the office. Donation labels will be available onsite at the GES service desk and the floor managers' desks located on the Show floor. Collection points will be clearly marked on the Show floor.

Personnel:

Booth must be staffed the entire time. To order additional staff please go to <https://ordering.ges.com/083600172/boothstaff>.

Photography/Videography Restrictions :

Exhibitor may take photos or videos of its displays; however, exhibitor is not permitted to directly take pictures of any other display or instruct others to take such pictures without written permission of Show Management and the exhibitor whose display is being photographed.

Privately Owned Vehicles/Hand Carried Items:

Please refer to GES at <https://ordering.ges.com/083600172/povmarshalingyard>.

Roaming Characters:

Roaming characters are not allowed at the Show. Any character in costume must stay within your contracted exhibit space. If roaming characters are found on the Show floor, they will be sent back to the exhibit space. If the roaming character is spotted again, the individual's badge will be confiscated and the individual will be asked to leave the Show floor.

Security:

Show Management, the building operator, the official exhibit services contractor (GES), and the security company (DTA Security Company) provide a measure of protection, such as providing perimeter security, but only you and your staff are responsible for your valuables. Some exhibitors hire designated booth guards to assist in this process. <https://ordering.ges.com/083600172/security>.

We have found that theft at trade shows is most likely to take place during the set-up and dismantling (move-in and move-out) of exhibits. You are responsible for the safety of your booth and all exhibit and personal items. If you would like to hire additional security, simply fill out the Booth Monitor Form in the ESK.

In order to ensure the best possible protection, we would like your cooperation working within the following guidelines to help safeguard your exhibit and your products.

- Don't identify the product or manufacturer on the outside of cartons, crates, boxes, etc. Mark these numerically to indicate the total being shipped (1 of 6, 2 of 6, etc.).

- Stay with your exhibit until your empty cartons are delivered and your goods are packed, sealed and properly labeled.
- Products or equipment given away should be accompanied by donation stickers available on the last day of the Show.
- Use “empty” containers for display purposes.
- After Show hours, cover your display and products.
- If you observe an attendee taking more samples than normal, please contact your floor manager.
- Move all samples and displays to the rear of your booth. Post signs encouraging attendees to take only one sample.
- Do not leave any items of value in your booth overnight. If you order in advance, GES has security cages available for equipment and larger items. You will need to supply your own lock and key for security cages rented from GES.
- Be sure you make all arrangements for your outbound shipping prior to leaving the Show floor.
- Be sure to turn in your Bill of Lading to the GES service desk after your freight is packed and ready to be picked up. Do not leave it in your booth with your freight.
- Remove all old labels from inbound shipping and apply new labels for outbound shipping.
- At the close of the Show, you may begin to pack up products within your exhibit space. Keep all aisles clear of crates, boxes and cartons until the carpeting has been rolled up in front of your booth.

Subletting booth space:

Please refer to the exhibit space contract.

Suitcasing/Soliciting:

Only exhibitors that have contracted with Show Management are permitted to promote their products, services or company at the Show. Unless a marketing opportunity has been contracted by the exhibitor, all company promotion and product sampling must occur within the contracted booth space. This includes, but is not limited to:

- Approaching exhibitor booths to sell products
- Leaving and/or distributing product information in public spaces and Show floor aisles

Exhibitors violating this policy will be sent back to their booth space and materials left will be recycled. Attendees violating this policy will be asked to leave the Show and forfeit their badges. Any "suitcasers" should be reported to the Show Office. Repeated violations will be reported to Security and may result in loss of priority points.

We make every effort to ensure exhibitors will not be solicited in their booths. However, this does occur at trade shows. Should you be approached in your booth, kindly take down the name and company of the solicitor and provide the information to the Show Office or your floor manager.

Termination Rights:

Show Management reserves the right to terminate at any time the privileges of any exhibitor if Show Management determines, in its sole discretion, that an exhibitor is conducting its exhibit in such a fashion that might reflect unfavorably upon Show Management or the Show. In the event of termination by Show Management, the exhibitor shall promptly remove all equipment and personnel from the exhibit area. No portion of payments paid or owed to Show Management on account of said exhibit shall be refundable.

Union Jurisdictions:

Please make sure you read and understand the *Show Site Work Rules* in the GES section of the ESK at <https://ordering.ges.com/083600172/worlrules>.

Variances:

Any displays not conforming to the exhibit specifications outlined in the exhibit space contract or booth guidelines in the ESK must apply for written approval from Show Management by submitting the Approval Request Form by the date listed in the critical dates and deadlines in the ESK. Non-conforming booth structures set up without pre-approved variances may need to be modified or removed from the exhibit hall.

Vehicles on Show Floor:

Please refer to GES at https://ordering.ges.com/083600172/vehicle_placement.

Violations:

Violations of any of these regulations on the part of the exhibitor or its employees or agents shall, at the option of Show Management, constitute cause for the termination of the exhibitor contract for exhibit space and could cause the exhibitor to be expelled from the Show. In the event this action is taken, the exhibitor will forfeit all fees paid and incur all related costs.

Waste Management:

Trash removal service is provided during Show hours and immediately after daily Show closing in the following areas: exhibit hall aisles (excluding exhibit booths), corridors, public space and areas used for meetings. Janitorial services are provided in restrooms throughout Show hours.

Exhibitors are responsible for cleaning their own booths (including but not limited to trash removal and vacuuming) or ordering service through GES. Show Management and GES are committed to reducing our environmental impact on the earth.

By incorporating environmentally-friendly practices into your trade show presence you will encourage your customers and peers to follow. Green business is good business!

IN ADDITION TO THESE RULES AND REGULATIONS AND ALL OTHER TERMS AND GUIDELINES SET FORTH IN THIS ESK, ALL EXHIBITORS MUST COMPLY WITH THE TERMS AND CONDITIONS APPLICABLE TO THE EXHIBIT SPACE CONTRACT AND ALL POLICIES, DIRECTIVES AND STANDARDS PUBLISHED ON THE SHOW WEBSITE OR OTHERWISE PROVIDED BY SHOW MANAGEMENT RELATING TO THE SHOW.

Booth Regulations and Guidelines

In-Line Booths

In-Line booths have one or two sides exposed to an aisle and are generally arranged in a series along a straight line. (5ft x 10ft, 8ft x 10ft, 10ft x 10ft, 10ft x 20ft, etc.) (1.52m x 3.05m, 2.43. x 3.05m, 3.05m x 3.05m, 3.05m x 6.10m, etc.)

- **In-Line Booth**: Generally arranged in a straight line with neighboring exhibitors on their immediate right and left leaving only one side exposed to the aisle. Individual booths may be combined to form a larger In-Line booth space.
- **Corner Booth**: In-Line booth exposed on two sides with an immediate neighbor on one side (all guidelines for In-Line booths apply).
- **Perimeter Wall Booth**: In-Line booth, backs to an outside wall of the exhibit facility rather than to another exhibit (10ft x 10ft) (3.05m x 3.05m)
- **Booth Block**: Six or more In-Line booths with a purchased aisle in between (contact your account managers for details). Booth blocks are permitted to carpet the entire contracted space, including the aisle if the aisle has been purchased.

Peninsula Booth

Exhibit with two or more standard booths (10ft x 10ft) (3.05m x 3.05m) with aisles on three sides. There are two types of Peninsula Booths.

- **Peninsula Booth**: Backs up to another Peninsula Booth, the two booths share a common back wall drape 8ft 3in (2.5m) high, 20x20 or larger.
- **End-Cap Peninsula Booth**: The booth shares a side wall with two In-Line booths on the exhibitors back wall.

Island Booth

Exhibit space enclosed by aisles on all four sides of the booth space. Island booths do not include drapery. Drapery can be ordered at an additional cost from GES if needed.

Multi-Story Booth

Exhibit spaces that have a 2nd-story.

Enclosed or Covered Area

Exhibit space enclosed by four walls and/or ceiling.

Canopy / Ceiling Regulations

An exhibit component supported over an exhibitor's space for decorative purposes only.

Pop-Up Tent

Pop-Up Tents are collapsible frames with four legs and a canvas cover. **Pop-Up tents are not allowed.**

Hanging Signs and Ceiling Rigging

- **Hanging Signs – See booth space for details.**

- **Lighting/Truss** – Hanging truss or suspending lights from facility ceiling requires approval.
- Exhibitors must also comply with the Show Rules and Regulations in the Exhibitor Service Kit.

Note: Exhibitors will be asked to remove any exhibits not in compliance with these guidelines. Items will be stored at exhibitor's expense.

Additional questions or clarification should be directed to your Client Services Specialist.

<http://www.expoeast.com/ee18/Public/Content.aspx?ID=1068616&sortMenu=109003>

Please remember building fire hoses, extinguishers, and audible or visual devices for fire alarms should be visible and accessible at all times.

Rules and Regulations are subject to change.

5 x 10 Booth Rules & Regulations

RULES

- Exhibits must be constructed with enough space to allow for utility service at the rear of booth (back drape, rails, power drop).
- Hanging signs are not allowed.
- Carpeting will be provided.
- Pop-Up Tents are not allowed.
- Front of booth – no items over 4ft (1.22m) in height can be within 2.5ft (.76m) of aisle (red area of diagram) as it blocks sight line.
- Rear of booth (maximum of 2.5ft (.76m) from the back drape in a 5ft x 10ft (1.52m x 3.05m) booth. Cannot exceed 8ft 3in (2.5m) in height.
- Any signage or side wall facing the neighbor cannot have any logo or identification facing the neighboring booth. Any side wall must be finished carpentry.
- Any portion of an exhibit over 8ft 3in (2.5m) is not allowed and will have to be moved or removed.
- When three or more In-Line booths are used in combination as a single exhibit space, the 4ft (1.22m) height limitation is applied only to that portion of exhibit space which is within 10ft (3.05m) of an adjoining booth.

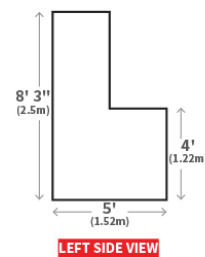
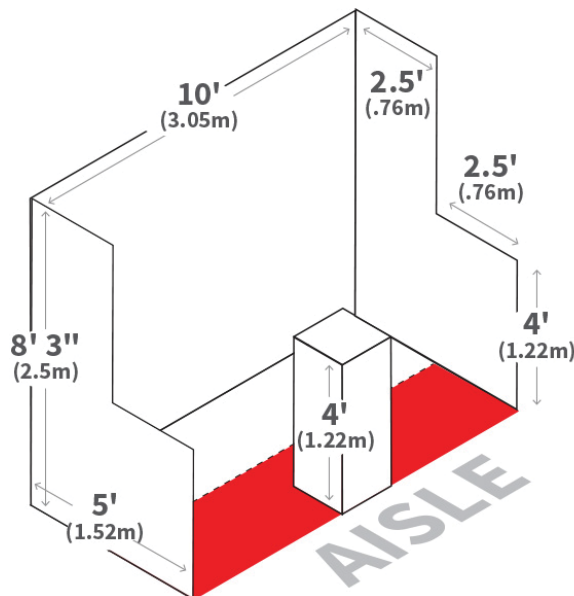

KEY

- 8' 3" (2.5m) Max. Height
- 4' (1.22m) Max. Height

5ft x 10ft (2.43m x 3.05m) In-Line

In-Line Booths

RULES

- Exhibits must be constructed with enough space to allow for utility service at the rear of booth (back drape, rails, power drop).
- Hanging signs are not allowed in In-Line Booths.
- Pop-Up Tents are not allowed.
- Front of booth – no items over 4ft (1.22m) in height can be within 5ft (1.52m) of aisle (red area of diagram) as it blocks sight line.
- Rear of booth (maximum of 5ft (1.52m) from the back drape in a 10ft x 10ft (3.05m x 3.05m) booth or maximum of 4ft (1.22m) in an 8ft x 10ft booth (2.43m x 3.05m) cannot exceed 8ft 3in (2.5m) in height.
- Any signage or side wall facing the neighbor cannot have any logo or identification facing the neighboring booth. Any side wall must be finished carpentry.
- Any portion of an exhibit over 8ft 3in (2.5m) is not allowed and will have to be moved or removed.
- When three or more In-Line booths are used in combination as a single exhibit space, the 4ft (1.22m) height limitation is applied only to that portion of exhibit space which is within 10ft (3.05m) of an adjoining booth.

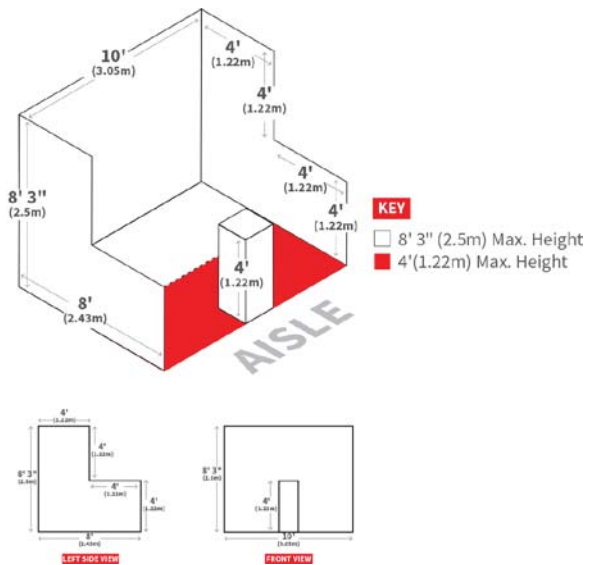

8ft x 10ft (2.43m x 3.05m) In-Line

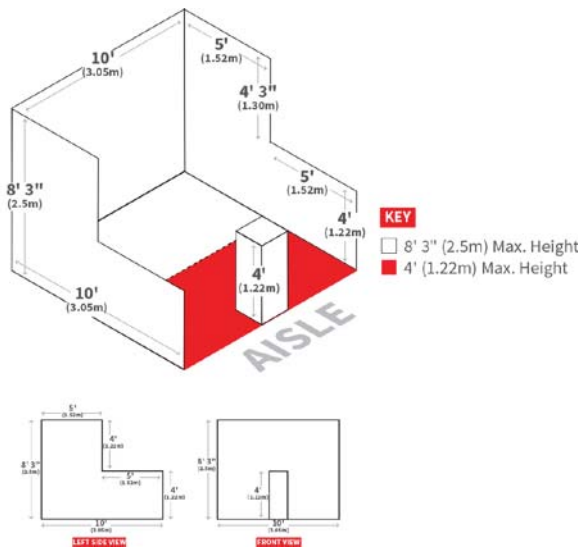

10ft x 10ft (3.05m x 3.05m) In-Line

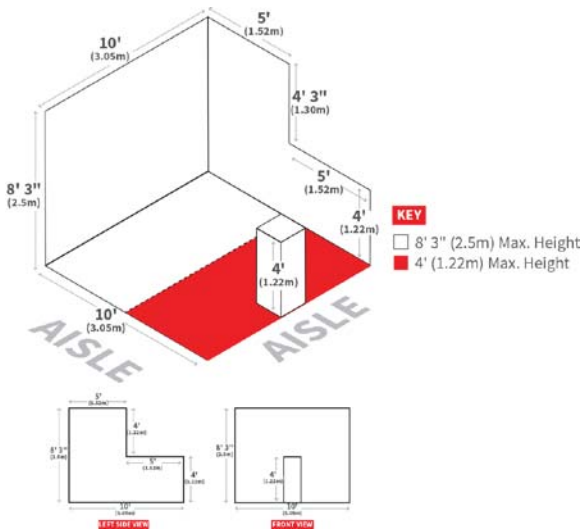

10ft x 10ft (3.05m x 3.05m) Corner

Perimeter Booth

RULES

- Exhibits must be constructed with enough space to allow for utility service at the rear of booth (back drape, rails, power drop).
- Hanging signs are not allowed in In-Line Booths.
- Pop-Up Tents are not allowed.
- Front of booth – No items over 4ft (1.22m) in height can be within 5ft (1.52m) of aisle (red area of diagram) as it blocks sight line.
- Rear of booth (maximum of 5ft (1.52m) from the back drape) cannot exceed 12ft (3.65m) in height.
- Any signage or side wall facing the neighbor cannot have any logo or identification facing the neighboring booth. Any side wall must be finished carpentry.
- Any portion of an exhibit over 12ft (3.65m) is not allowed and will have to be moved or removed.
- When three or more In-Line booths are used in combination as a single exhibit space, the 4ft (1.22m) height limitation is applied only to that portion of exhibit space which is within 10ft (3.05m) of an adjoining booth.
- Design your booth so that it can be used either at the 8ft 3in (2.5m) height or the 12ft (3.65m) height, so that it will not have to be reconstructed if a 12ft (3.65m) perimeter-wall space is not available at a future show.

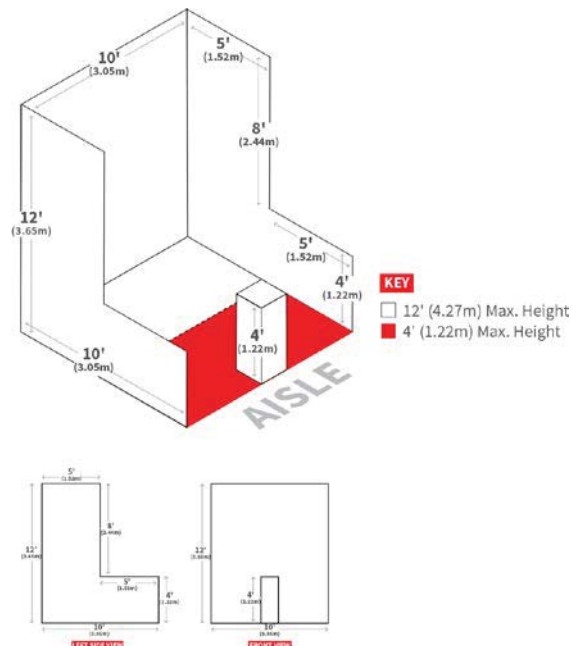

Booth Block

RULES

- Exhibits must be constructed with enough space to allow for utility service at the rear of booth (back drape, rails, power drop).
- Pop-Up Tents are not allowed.
- No items over 4ft (1.22m) in height can be within 5ft (1.52m) of aisle next to the neighboring booth.
- Rear of booth (maximum of 5ft (1.52m) from the back drape) cannot exceed 8ft 3in (2.5m) in height.
- Any signage or side wall facing the neighbor cannot have any logo or identification facing the neighboring booth. Any side wall must be finished carpentry.
- Any portion of an exhibit over 8ft 3in (2.5m) is not allowed and will have to be moved or removed.
- When three or more In-Line booths are used in combination as a single exhibit space, the 4ft (1.22m) height limitation is applied only to that portion of exhibit space which is within 10ft (3.05m) of an adjoining booth.
- Aisle Use: Exhibitors purchasing a booth block are permitted to carpet the aisle with their own logo carpeting. Aisles must remain clear to allow for traffic flow.
- Hanging Signs are allowed with approval.

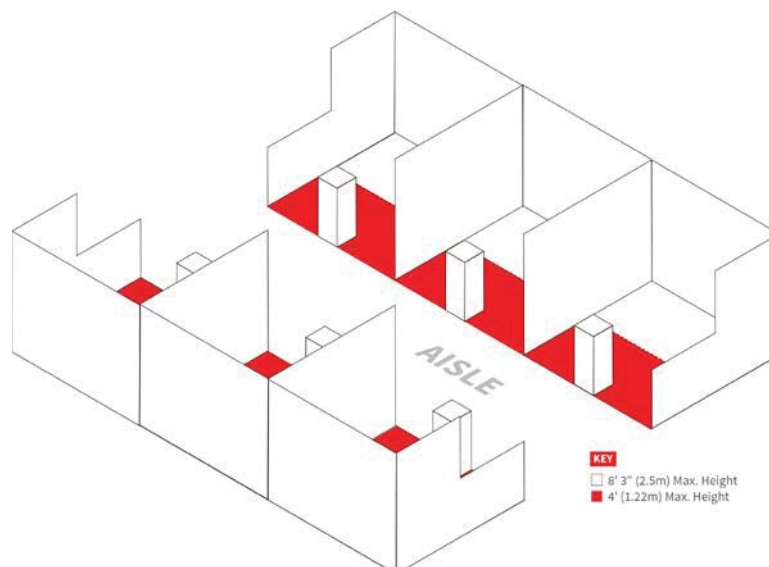

Peninsula Booth

RULES

- Exhibits must be constructed with enough space to allow for utility service at the rear of booth (back drape, rails, power drop).
- Pop-Up Tents are not allowed.
- Hanging signs must be set back 10ft (3.05m) from the adjacent booth and no higher than 20ft (6.10m) from top of sign to the floor. Booth height may not exceed 16ft (4.88m).
- Booths share a back-wall drape of 8ft 3in (2.5m) high.
- Any signage facing the neighbor (behind) cannot have any logo or identification facing the neighboring booth.
- The back wall of any booth must be finished carpentry on the back side facing other booths.
- Hanging Signs are allowed with approval.

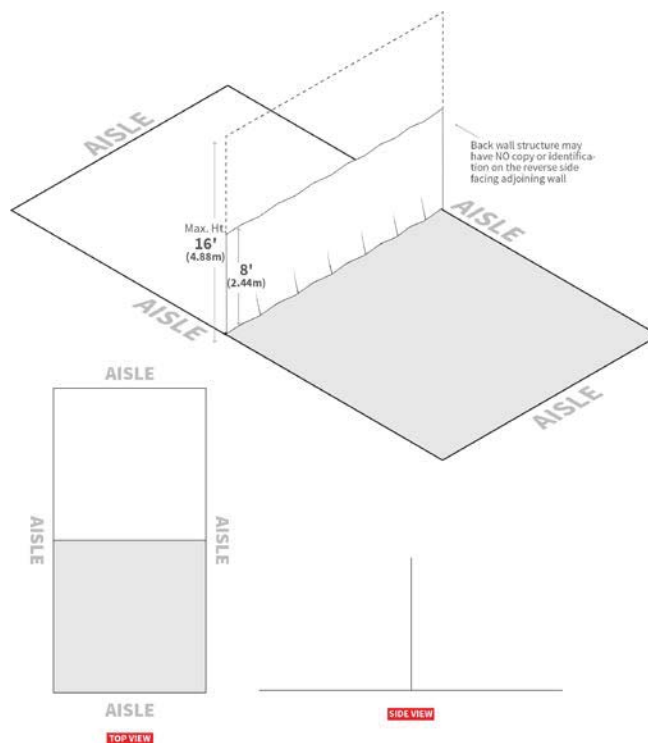

End-Cap Peninsula Booth

RULES

- Exhibits must be constructed with enough space to allow for utility service at the rear of booth (back drape, rails, power drop).
- Pop-Up Tents are not allowed.
- Hanging signs must be set back 10ft (3.05m) from the adjacent booth and no higher than 20ft (6.10m) from top of sign to the floor.
- Sixteen feet (16ft) (4.88m) is the maximum height allowance, including signage for the center portion of the back wall (where ceiling heights permit).
- When an End-Cap Peninsula Booth backs up to two In-Line booths, the back wall is restricted to 4ft (1.22m) high within 5ft (1.52m) of each aisle, permitting adequate line of sight for the adjoining In-Line booths.
- The back wall of any booth must be finished carpentry on the back side facing other booths. Any signage facing the neighbor (behind) cannot have any logo or identification facing the neighboring booth.
- The center portion of the structure may extend from the back of the booth to the aisle.
- Hanging Signs are allowed with approval.

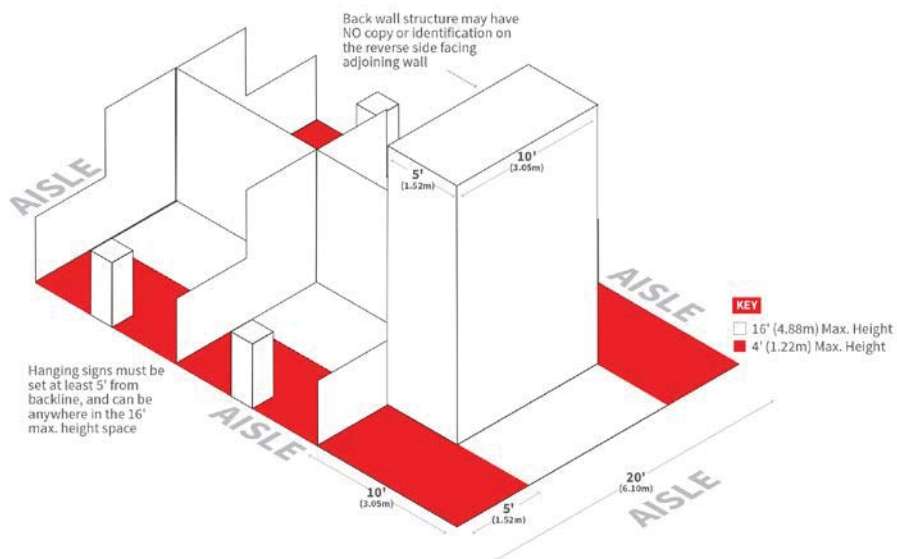

10ft x 20ft (1.05m x 6.10m) End-Cap Peninsula

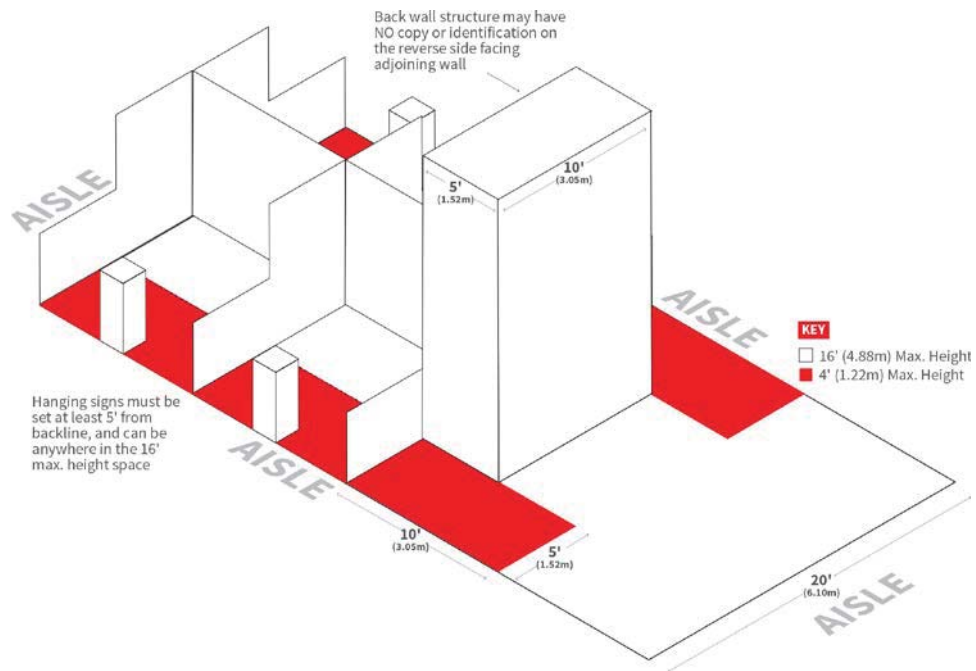

20ft x 20ft (6.10m x 6.10m) End-Cap Peninsula

Island Booth

RULES

- Exhibitors are prohibited from installing roofed or multi-story exhibit booths (double-deck) without advance written approval from Show Management and Fire Marshal.
- Hanging signs are allowed with approval.
- Booth structure cannot exceed 16ft (4.88m) in height.
- Hanging sign cannot exceed 20ft (6.10m) in height from the top of the sign to the floor.

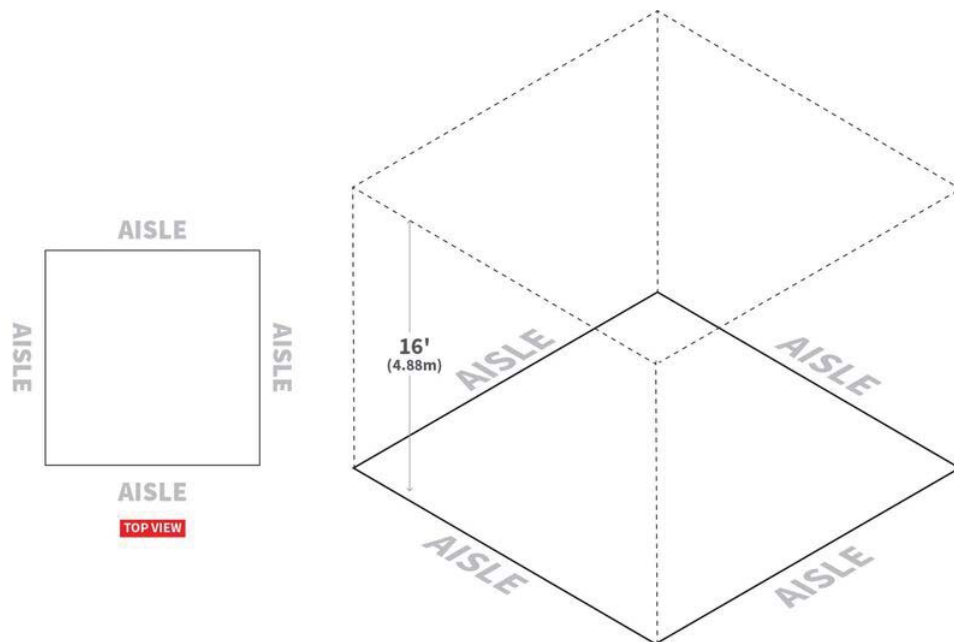

- **Multi-Story Booth:** All multi-Story exhibits, regardless of whether people will occupy the upper area or not, and all exhibit fixtures and components exceeding 16ft (4.88m) in height, must have drawings available for inspection at all times. Please review all facility rules and regulations regarding multi-story booths <https://ordering.ges.com/083600172/convcenterregs>.

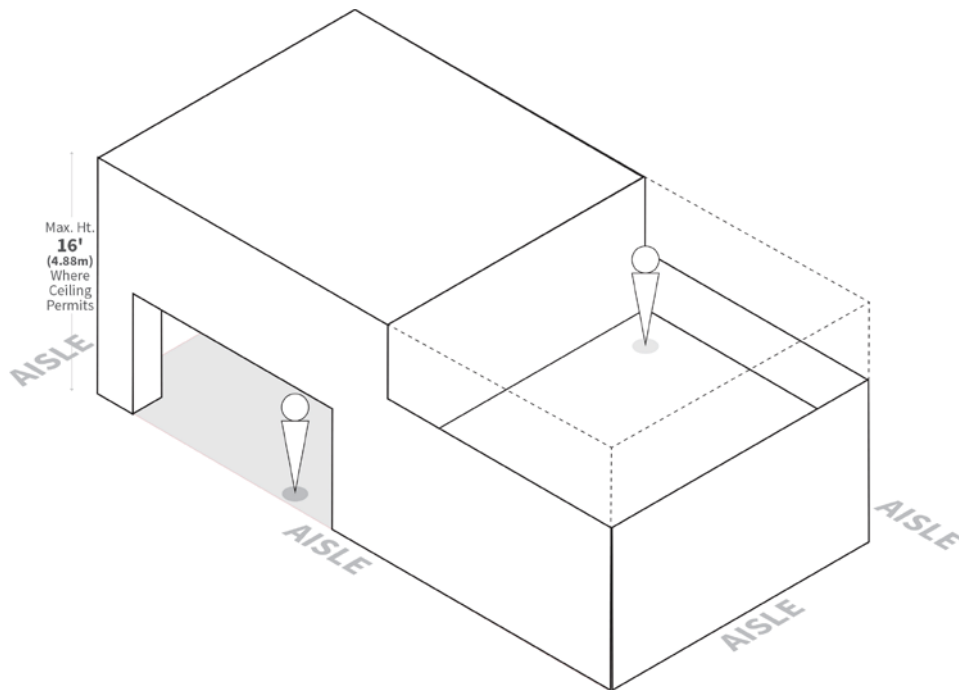

- **Enclosed or Covered Area:** Review the building rules and regulations. <https://ordering.ges.com/083600172/convcenterregs>.

Hanging Signs and Ceiling Rigging

Hanging Sign Regulations:

Hanging signs will only be permitted in Booth Blocks, Island Booths, Peninsula Booths and End-Cap Peninsula Booths (20x20 or larger). Hanging signs are not permitted over In-Line Booths, 10x20 End-cap Peninsula Booths or Tabletops.

Signs hung without approval will be removed at the exhibitor's expense.

Definition: An exhibit component suspended above or displayed on top of an exhibit for the purpose of displaying graphics or identification.

Height: Hanging identification signs and graphics will be permitted to a maximum height of 20ft (6.10m) (where ceiling heights allow) from the top of the sign to the floor. Hanging signs must be set back 10ft (3.05m) from adjacent booths.

Intent: Hanging signs are part of the overall exhibit presentation. All identifying signs, whether suspended from the ceiling (hung) or attached to the exhibit fixture (ground supported), will be permitted to a maximum height of 20ft. Booth structure may not go higher than 16ft unless solely used for supporting an identifying sign in lieu of hanging from the ceiling.

Please contact GES to order rigging and confirm service availability. All Hanging Signs must be shipped to the GES advanced warehouse prior to the event to receive discount pricing – DEADLINE September 5, 2018. Signs shipped direct to show site may not be able to be hung.

<https://ordering.ges.com/083600172/labels>.

Lighting/Truss:

Exhibitors intending to use hanging light systems should include those items when submitting drawings for approval. No overhead lighting is allowed outside the boundaries of the exhibit space.

- All material used in construction and decoration of an exhibit must be flame retardant. Fabrics must be certified as flame retardant or a sample must be available for testing. Materials which cannot be treated to meet the requirements may not be used.
- All exits and exit aisles must be kept clear and unobstructed. No furniture, signs, easels, chairs or displays may protrude into aisles. All aisles must be maintained at a minimum of eight (8) feet in width unless otherwise approved on a floor plan.
- Designated "no freight" aisles must be maintained clear of crates and exhibit materials during move-in and move-out. These aisles are required for emergency access throughout the hall and to expedite freight and empty crate moving.
- All fire hose racks, fire extinguishers and emergency exits must be visible and accessible at all times. This includes fire protection equipment located within exhibits. Exits and exit signs must not be covered by drapes nor obscured from view by exhibit components.
- Vehicles on display must have fuel filler caps locked or sealed to prevent escape of vapors and to avoid tampering. Batteries must be disconnected. Auxiliary batteries not connected to engine starting system may be left connected. External chargers are recommended for demonstration purposes. Fuel in the fuel tank shall not exceed one quarter (1/4) of the tank capacity or five (5) gallons, whichever is less.
- Combustible materials cannot be stored beneath display vehicles. Space beneath vehicles must be clear and visible except for permitted electrical supplies.
- Vehicles in building for unloading must not be left with engine idling. Exhaust gases present extreme hazards to workers on catwalks. If an engine cannot be shut down, the vehicle must be removed from the building as quickly as possible.
- Compressed air cylinders, including LPG, are prohibited unless approved by the fire prevention office. Flammable gases, i.e., butane, propane, natural gas, et al; are subject to prior approval. Nonflammable compressed gas cylinders must be secured in an upright position with gauges and regulator protected against physical damage.
- All 110 volt extension cords shall be three-wire (grounded), #14 or larger AWG, copper wire. Connectors must not be supported by cords. Two wire "Zip Cords" are not permitted other than factory installed appliance connectors, these may not exceed six (6) feet in length and must be UL approved.
- Cube tap adapters are prohibited (Uniform Fire Code 8507). Multi-plug adapters must be UL approved and have built-in overload protection. Connectors must not be used to exceed their listed ampere rating.
- Electrical work under carpets must be done, or supervised, by the electrical contractor. All wiring on the floor must be Type "SO" cord, insulated to qualify for "extra hard usage", must be No. 12AWG or larger, and must be protected against injury or damage.
- All temporary wiring must be accessible and free from debris and storage materials. Hard backed booths must have power supplies dropped within the booth.
- No storage of any kind is allowed behind booths or near electrical service. Materials for handouts must be limited to a one-day supply and stored neatly within the booth. Violators will be notified and if the materials are not removed by show opening, show decorator will remove and store them at the exhibitor's expense, without access until the break of the show.
- Areas enclosed by solid walls and ceilings must be equipped with approved smoke detectors.
- All empty cartons or crates must be labeled and removed for storage or they will be removed as trash. Crates are not to be used as exhibit supports.
- Flammable or combustible liquids are prohibited inside of buildings except as approved by the fire prevention office. Flammable thinners, solvents and paints including aerosol cans are strictly prohibited within the building.
- Cooking and warming devices shall be electric. Sterno may be used for warming trays. Cooking devices shall be approved by a recognized testing laboratory; e.g., U.L., F.M. Cooking, warming devices, and/or heated products shall be isolated from the public by either placing the device a minimum of four (4) feet back from the front of the booth or provide a plexiglass shield 18 inches high, ¼ inch thick across the front, and down both sides of the demonstration area. Decorative candles are not permitted.

- Heat producing equipment is prohibited. Examples of prohibited equipment include, welding, soldering, or any open flame devices.

COI – Certificate of Insurance Instructions

1. **PRODUCER:** Insurance Agent / Broker who issues certificate.
2. **NAME OF INSURED:** Must be the legal name of contracting party/COMPANY NAME (the one who is purchasing the insurance)
3. **TYPES OF INSURANCE:** Must include types required by contract.
4. **FORM OF COVERAGE:** Must be "occurrence" form of coverage.
5. **NAME ADDITIONAL INSUREDS:** Global Experience Specialists, Inc. (GES) (Official Service Provider), (Show Management), Natural Products Expo East, Harvest Festival (Show) and Baltimore Convention Center (Facility) as additional insureds on a primary and non-contributory basis.
6. **CERTIFICATE HOLDER:**
Informa
5541 Central Avenue, Suite 150
Boulder, CO 80301
7. **POLICY EFFECTIVE DATE:** Must be prior to or coincidental with the first day of Exhibitor Move-In.
8. **POLICY EXPIRATION DATE:** Must be on or after the last day of Exhibitor Move-Out.
9. **LIMITS OF INSURANCE:** Must be the same or greater than required by contract.
 - Commercial General Liability with limits of not less than \$1,000,000 each occurrence, \$2,000,000 general aggregate and \$2,000,000 products & completed operations aggregate.
 - Automobile Liability with a limit of not less than \$1,000,000 combined single limit - each accident.
 - Umbrella/Excess Liability with a limit of not less than \$1,000,000 each occurrence and {\$1,000,000} each aggregate.
 - Workers Compensation, as required by law, with Employers Liability Limits of not less than {\$1,000,000} each accident, {\$1,000,000} disease - each employee and {\$1,000,000} disease - policy limit.
10. **AUTHORIZED REPRESENTATIVE:** Must be signed (not stamped) by an authorized representative of Producer.

Please keep a copy of your COI in your booth, we do not collect them.

Thank you!

Fire Regulations

All orders are governed by the GES Payment Policy and GES Terms & Conditions of Contract as specified in this Exhibitor Services Manual.

Natural Products Expo East / All Things Organic™ BioFach America
Baltimore Convention Center
September 13 - 15, 2018

All material used in construction and decoration of an exhibit must be flame retardant. Fabrics must be certified as flame retardant or a sample must be available for testing. Materials which cannot be treated to meet the requirements may not be used.

All exits and exit aisles must be kept clear and unobstructed. No furniture, signs, easels, chairs or displays may protrude into aisles. All aisles must be maintained at a minimum of eight (8) feet in width unless otherwise approved on a floor plan.

Designated "no freight" aisles must be maintained clear of crates and exhibit materials during move-in and move-out. These aisles are required for emergency access throughout the hall and to expedite freight and empty crate moving.

All fire hose racks, fire extinguishers and emergency exits must be visible and accessible at all times. This includes fire protection equipment located within exhibits. Exits and exit signs must not be covered by drapes nor obscured from view by exhibit components.

Vehicles on display must have fuel filler caps locked or sealed to prevent escape of vapors and to avoid tampering. Batteries must be disconnected. Auxiliary batteries not connected to engine starting system may be left connected. External chargers are recommended for demonstration purposes. Fuel in the fuel tank shall not exceed one quarter (1/4) of the tank capacity or five (5) gallons, whichever is less.

Combustible materials cannot be stored beneath display vehicles. Space beneath vehicles must be clear and visible except for permitted electrical supplies.

Vehicles in building for unloading must not be left with engine idling. Exhaust gases present extreme hazards to workers on catwalks. If an engine cannot be shut down, the vehicle must be removed from the building as quickly as possible.

Compressed air cylinders, including LPG, are prohibited unless approved by the fire prevention office. Flammable gases, i.e., butane, propane, natural gas, et al; are subject to prior approval. Nonflammable compressed gas cylinders must be secured in an upright position with gauges and regulator protected against physical damage.

All 110 volt extension cords shall be three-wire (grounded), #14 or larger AWG, copper wire. Connectors must not be supported by cords. Two wire "Zip Cords" are not permitted other than factory installed appliance connectors, these may not exceed six (6) feet in length and must be UL approved.

Cube tap adapters are prohibited (Uniform Fire Code 8507). Multi-plug adapters must be UL approved and have built-in overload protection. Connectors must not be used to exceed their listed ampere rating.

Electrical work under carpets must be done, or supervised, by the electrical contractor. All wiring on the floor must be Type "SO" cord, insulated to qualify for "extra hard usage", must be No. 12AWG or larger, and must be protected against injury or damage.

All temporary wiring must be accessible and free from debris and storage materials. Hard backed booths must have power supplies dropped within the booth.

No storage of any kind is allowed behind booths or near electrical service. Materials for handouts must be limited to one day supply and stored neatly within the booth. Violators will be notified and if the materials are not removed by show opening, show decorator will remove and store them at exhibitors expense, without access until the break of the show.

Areas enclosed by solid walls and ceilings must be equipped with approved smoke detectors.

All empty cartons or crates must be labeled and removed for storage or they will be removed as trash. Crates are not to be used as exhibit supports.

Flammable or combustible liquids are prohibited inside of buildings except as approved by the fire prevention office. Flammable thinners, solvents and paints including aerosol cans are strictly prohibited within the building.

Cooking and warming devices shall be electric. Sterno may be used for warming trays. Cooking devices shall be approved by a recognized testing laboratory; e.g., U.L., F.M. Cooking, warming devices, and/or heated products shall be isolated from the public by either placing the device a minimum of four (4) feet back from the front of the booth or provide a plexiglass shield 18 inches high, ¼ inch thick across the front, and down both sides of the demonstration area. Decorative candles are not permitted.

Heat producing equipment is prohibited. Examples of prohibited equipment include, welding, soldering, or any open flame devices.

083600172

080118

G-8 042718

Show Site Work Rules

All orders are governed by the GES Payment Policy and GES Terms & Conditions of Contract as specified in this Exhibitor Services Manual.

Natural Products Expo East / All Things Organic™ BioFach America
Baltimore Convention Center
September 13 - 15, 2018

Union Information

To assist you in planning your participation in your show, we are certain you will appreciate knowing in advance that union labor will be required for certain aspects of your exhibit handling.

Carpenter Union

The installation and dismantling of prefabricated displays comes under the jurisdiction of the Carpenter's Union. This includes signs and laying of carpet.

Members of this union claim jurisdiction on the operation of all material handling equipment, all unloading and reloading, and handling of empty containers. An exhibitor may move materials that can be carried by hand, by one person in one trip, without the use of dollies, hand trucks, or other mechanical equipment.

The Official Service Contractor shall be responsible for all matters in the Dock area. This shall include but not limited to such items as assignment of dock space and loading or unloading of all materials and equipment.

Trade and Public Shows

Two (2) full-time exhibitor employees may work without Carpenter labor for one (1) hour on the move in and one (1) hour on the move out, for booths that are larger than 10'x10'. Exhibitors may work in booths 10'x10' or smaller without the use of Union labor.

The use of power tools is not permitted. As an exhibitor, you will be pleased to know that there are no restrictions or requirements to use union labor for the unpacking and placement of your merchandise or product and equipment tuning or calibrating, provided exhibitors use full-time permanent employees.

Gratuities

Our work rules prohibit the solicitation or acceptance of tips in cash, product or gifts in kind by any employee (union or non-union). Our employees are paid appropriate wages denoting professional status, therefore tipping of any kind is not allowed.

Work Zone

Customer acknowledges that the show site and surrounding areas are active work zones. Customer, its agents, employees and representatives are present at their own risk.

Always Honest Hotline

GES requires the highest standards of integrity from all employees. Please call our confidential Always Honest Hotline at (866) 225-8230 to report fraudulent or unethical behavior.

083600172

G-6 071718

Stop. Think. Safety.

All orders are governed by the GES Payment Policy and GES Terms & Conditions of Contract as specified in this Exhibitor Services Manual.

Natural Products Expo East / All Things Organic™ BioFach America
Baltimore Convention Center
September 13 - 15, 2018



Safety is very important for everyone working in the Exhibit Hall.

GES values safety throughout our organization and demonstrates it in the work we perform. By following the safety guidelines below you will be doing your part in creating a safe work environment.

Safety Guidelines:

- Only authorized personnel and employees allowed, all others are prohibited.
- This is an active work zone.
- All exhibitors and attendees enter at their own risk. Do not enter the dock/yard areas.
- Stay clear of heavy machinery.
- Never stand on furniture.
- Wear closed toe shoes.
- Clean up or report spills.
- Keep aisles free and clear of any and all debris.
- Practice good housekeeping.
- Check electrical cords for damage.
- Protect valuables at show site.
- Report any fires immediately.

If you notice anything unsafe please contact a GES employee immediately.

No individuals under the age of 18 are permitted on the show floor at any time. Show sites during these times are similar to a construction zone and considered to be hazardous. OSHA regulations prohibit minors from being present in a hazardous work environment.

080118 083600172

G-5 102617

General Information

All orders are governed by the GES Payment Policy and GES Terms & Conditions of Contract as specified in this Exhibitor Services Manual.

Natural Products Expo East / All Things Organic™ BioFach America
Baltimore Convention Center
September 13 - 15, 2018

What is an Official Service Provider?

- GES has been selected as the Official Service Provider by the show organizer to design and produce your show.
- We can save you time and money with our insight and experience of the show process. As the Official Service Provider, GES will assist you in your pre-show planning from start to finish.
- We are at your service for all your exhibiting needs.

GES Show Services

- Carpet
- Booth Furniture and Accessories
- Custom Exhibits and Rental Exhibits
- Graphics
- Installation and Dismantle Services
- Overhead Lighting and Rigging

Work Zone



- Customer acknowledges that the show site and surrounding areas are active work zones. Customer, its agents, employees and representatives are present on the show floor at their own risk.

How Can I Order My Show Services?



Expresso is GES' planning, ordering and management system. Order everything you need for your tradeshow exhibits, view account order history, download the show schedule and more.

- Go to <https://e.ges.com/083600172/esm>
- Log in or sign up with a new account
- Browse products and services and you will be guided through the ordering process



GES National Servicenter® provides consistency and continuity of customer service for exhibitors at shows:

- Phone: (800) 475-2098 / Fax: (866) 329-1437
- International phone: (702) 515-5970 / Fax: (702) 263-1520
- Contact us online: <https://e.ges.com/083600172/contactus/esm>

GES Servicenter® is on-site to place any last-minute orders and provide show information while at show site.

Exhibitor Services

- Our Exhibitor Services team is responsible for answering exhibitor questions, processing your orders and handling any special requests.

083600172

080118

G-11 122016

GES Terms and Conditions of Contract

All orders are governed by the GES Payment Policy and GES Terms & Conditions of Contract as specified in this Exhibitor Services Manual.

Natural Products Expo East / All Things Organic™ BioFach America
Baltimore Convention Center
September 13 - 15, 2018

GES Terms & Conditions are subject to change at GES' sole discretion without notice to any parties.

I. Definitions

GES: GES as referenced hereinafter shall include, but is not limited to the following services: electrical (a/k/a TSE/Trade Show Electrical), rigging, material handling, installation and dismantle, and logistics provided by GES personnel to exhibitor pursuant to any purchase of Services. **Agents:** GES' agents, sub-contractors, carriers and the agents of each; **Customer:** Exhibitor or other party requesting Services from GES; **Goods:** Exhibits, property and commodities of any type for which GES is requested to perform Services; **Carrier:** Motor carrier, van line, air carrier or air or surface freight forwarder; **Shipper:** Party who tenders Goods to Carrier for transportation; **Cold Storage:** Holding of Goods in a climate controlled area; **Accessible Storage:** Holding of Goods in an area from which Goods may be removed during shows; **Services:** Warehousing, transportation, drayage, unsupervised labor, supervised labor and/or related services; **Show Site:** The venue or place where an exposition or event takes place; **Supervised Labor (OK TO PROCEED):** Union labor that is provided to a Customer to install or dismantle a booth or exhibit space, and is supervised and/or directed by GES; **Unsupervised Labor (DO NOT PROCEED):** Union labor that is provided to a Customer to install or dismantle a booth or exhibit space and pursuant to Customer's election is not supervised and/or directed by GES. Customer assumes the responsibility and any liability arising therefrom, for the work of union labor when Customer elects to use unsupervised labor.

II. Scope

These Terms and Conditions shall be binding upon Customer, GES, and their respective Agents and representatives, including but not limited to Customer contracted labor such as Customer Appointed Contractors and Installation and Dismantle Companies, and any other party with an interest in the Goods. Each shall have the benefit of and be bound by all provisions stated herein, including but not limited to time limits and limitations of liability.

III. Customer Obligations

a. **Payment for Services:** Customer shall be liable for all unpaid charges for services performed by GES or agents. Customer authorizes GES to charge its credit card directly for services rendered on Customer's behalf after departure, by placing an order online, via fax, phone or through a work order on site.

b. **Credit Terms:** All charges are due before Services are performed unless other arrangements have been made in advance. GES has the right to require prepayment or guarantee of the charges at the time of request for Services. A failure to pay timely will result in Customer having to pay in cash in advance for future Services. GES retains its right to hold Customers' Goods for non-payment. If a credit card is provided to GES, GES is authorized to bill to such credit card any unpaid charges for Services provided to Customer, including charges for return shipping. Any charges not paid within 30 days of delivery will be subject to interest at 1.5% per month until paid.

IV. Mutual Obligation Indemnification

a. **Customer to GES:** Customer shall defend, hold harmless and indemnify GES from and against any claims, lawsuits, demands, liability, costs and expenses, including reasonable attorneys' fees and court costs, resulting from any injury to or death of persons, or damage to property other than Goods, relating to or arising from performance of Services herein. Customer agrees to indemnify and hold GES harmless for any and all acts of its representatives and agents, including but not limited to Customer Appointed Contractors and Installation and Dismantle Companies, any subtenant or other user of its space or any agents or employees engaged in business on behalf of Customer or present at Customers' invitation, including supervision of labor secured through GES. Customer's obligations under this provision shall not apply to GES' own negligence and/or willful misconduct. **CUSTOMER ACKNOWLEDGES THAT THE SHOW SITE IS AN ACTIVE WORK ZONE AND CUSTOMER, ITS AGENTS, EMPLOYEES AND REPRESENTATIVES ARE PRESENT AT THEIR OWN RISK.**

b. **GES to Customer:** To the extent of GES's own negligence and/or willful misconduct and subject to the limitations of liability below, GES shall defend, hold harmless and indemnify Customer from and against any claims, lawsuits, demands, liability, costs and expenses including reasonable attorneys' fees and court costs, resulting from any injury to or death of persons or damage to property other than Goods. GES' obligations under this provision shall not apply to claims for bodily injury arising a) from Customer's presence in areas which have been marked as "off limits to exhibitors"; and b) when exhibitors are present in the facility prior or subsequent to the effective dates or hours of Exhibitor's space lease with show management.

V. Disclaimer and Limitation of Liability

UNDER NO CIRCUMSTANCES WILL ANY PARTY BE LIABLE FOR SPECIAL, INCIDENTAL, CONSEQUENTIAL INDIRECT OR PUNITIVE DAMAGES, INCLUDING BUT NOT LIMITED TO LOSS OF PROFITS OR INCOME. GES SHALL BE LIABLE, SUBJECT TO THE LIMITATIONS CONTAINED HEREIN, FOR LOSS OR DAMAGE TO GOODS ONLY IF SUCH LOSS OR DAMAGE IS CAUSED BY THE DIRECT NEGLIGENCE OR WILLFUL MISCONDUCT OF GES. CLAIMS PRESENTED FOR LOSS OR DAMAGE ARISING OUT OF INCIDENTS REFERENCED IN SECTION VI HEREIN WILL BE DENIED.

VI. No Liability for Loss or Damage to Goods

- a. **Condition of Goods:** GES shall not be liable for damage, loss, or delay to uncrated freight, freight improperly packed, glass breakage or concealed damage. GES shall not be liable for ordinary wear and tear in handling of Goods or for damage to shrink wrapped Goods. All Goods shall be able to withstand handling by heavy equipment, including but not limited to forklifts, cranes, or dollies. It is the Customer's responsibility to ensure that Goods are packaged correctly prior to shipment or movement on or off the Show floor.
- b. **Receipt of Goods:** GES shall not be liable for Goods received without receipts, freight bills or specified unit counts on receipts or freight bills or for bulk shipments (i.e., UPS, air freight, or van lines). Such Goods shall be delivered to booth without the guarantee of piece count or condition.
- c. **Force Majeure:** GES shall not be liable for loss or damage that results from Acts of God, weather conditions, act or default of Customer, shipper, or the owner of the Goods, inherent nature of the Goods, public enemy, public authority, labor disputes and acts of terrorism or war.
- d. **Cold Storage:** Goods requiring cold storage are stored at Customer's own risk. GES assumes no liability or responsibility for Cold Storage.
- e. **Accessible Storage:** GES assumes no liability for loss or damage to Goods while in Accessible Storage. Storage charges are for the use of space and are not a form of insurance, or a guarantee of security.
- f. **Unattended Goods:** GES assumes no liability for loss or damage to unattended Goods received at Show Site at any time from the point of receipt of inbound Goods until the loading of the outbound Goods, including the entire term of the respective show or exhibition. Customer is responsible for insuring its own Goods for any and all risk of loss.
- g. **Empty Storage:** GES assumes no liability for loss or damage to Goods or crates or the contents therein, while containers are in Empty Storage. It is Customer's sole responsibility to affix the appropriate labels available at the GES Service Desk for empty container storage, and ensures that any pre-existing empty labels are removed.
- h. **Forced Freight:** GES is not liable for Customer Goods left on the show floor after the show closing deadline, with or without a Material Handling Services/Straight Bill of Lading signed by Customer. It is Customer's responsibility to complete accurate paperwork for shipping and to ensure Customer Goods are properly labeled. If Customer Goods remain on the floor after the show closing deadline, GES has the right to remove the Customer Goods. GES is authorized by Customer to proceed in the manner chosen by Customer on the Order for Material Handling Services/Straight Bill of Lading, if one has been completed, or otherwise to ship Customer Goods at the discretion of GES and at Customer's expense. GES shall incur no liability for such shipment. GES retains the right to dispose of Customer Goods without liability if left on the show floor unattended, without labels or not correctly labeled.
- i. **Concealed Damage:** GES shall not be liable for concealed loss or damage including but not limited to; glass, electronic equipment, prototypes, original art, uncrated Goods, or improperly packaged or labeled Goods.
- j. **Unattended Booth:** GES shall not be liable for any loss or damage occurring while the Goods are unattended in Customer's booth at any time including, but not limited to, the time the Goods are delivered to the dock until the time the Goods are received by Customers' chosen carrier. All Material Handling Forms and/or Straight Bills of Lading covering outgoing Goods submitted to GES will be checked at the time of pickup from the booth and corrections to the count or condition will be documented where discrepancies exist.
- k. **Hanging items from Booth:** Customer shall not hang any articles, merchandise, product, advertisements, or other similar items from GES supplied booth materials, (this includes but is not limited to GEM panels or pipe and drape), utilized in Customer's own booth set up or in areas occupied by the show organizer or third parties. If Customer does hang any prohibited items, Customer alone shall be held liable for any damages, costs, actions or injuries resulting from the hanging of such item(s). GES shall have no liability for any damages, costs, actions or injuries arising out of Customer's failure to comply with this provision.

VII. Measure of Damage

- a. **Sole Relief:** If found liable for any loss, GES' sole and exclusive maximum liability for loss or damage to Customer's Goods is limited to \$.50 (USD) per pound with a maximum liability of \$100.00 (USD) per container, or \$1,500.00 (USD) per shipment whichever is less.
- b. **Labor:** GES assumes no liability for loss, damage, or bodily injury arising out of Customer's supervision of GES provided union labor. If GES supervises labor for a fee, GES shall be liable only for actions or claims arising out of its negligent supervision. Such liability shall be limited to the cost to Customer of the supervised labor or the depreciated value of the Goods, whichever is less. If Customer elects to use unsupervised labor, then Customer assumes all liability for the actions or claims that arise out of such work, including but not limited to loss, damage or bodily injury and shall provide GES and show management with an indemnity, including defense costs, for any claims that result from Customers' supervision or failure to supervise assigned labor.

VIII. Miscellaneous

- a. **Insurance:** **GES IS NOT AN INSURANCE COMPANY AND DOES NOT OFFER OR PROVIDE INSURANCE.** It is the obligation of Customer to ensure Goods are insured at all times. Loss or theft of the Goods in storage or in transit to and from the show and or while on the show floor is the sole responsibility of Customer. GES recommends Customer arrange for all Risk Coverage.
- b. **Notice of Loss or Damage:** In order to have a valid claim, notice of loss or damage to Goods must be given to GES or its agent within 24 hours of occurrence (as evidenced in an Incident Report completed at Show Site by GES) or delivery of outbound Goods.
- c. **Filing of Claim:** Any claim for loss or damage to Goods must be in writing, containing facts sufficient to identify the Goods, asserting liability for alleged loss or damage, and making claim for the payment of a specified or determinable amount of money. Such claim must be filed with the appropriate party within the time limits specified herein. Damage reports, incident reports, inspection reports, notations of shortage or damage on freight bills or other documents, do not constitute filing of a claim. Claims for Goods alleged to be lost, stolen or damaged at the Show Site must be received in writing by GES within **thirty (30)** days after the close of the show. Claims for Goods alleged to be lost or damaged **during transit** must be received by the responsible party within nine (9) months of date of delivery of Goods. GES Logistics subcontracts the movement of Goods to third party carriers. Claims for damage in transit should be made directly with your carrier as shown on the Material Handling form/ Bill of Lading. In the event of a dispute with GES, Customer will not withhold payment or any amount due GES for Services as an offset against the amount of the alleged loss or damage. Customer agrees to pay GES prior to the close of the show for all such charges and further agrees that any claim Customer may have against GES shall be pursued independently by Customer as a separate action to be resolved on its own merits. GES retains the right to pursue collection on amounts owed after show close, without regard to any amount alleged to be owed for damage, or loss.
- d. **Filing of Suit:** Any action at law regarding loss or damage to Goods must be filed within one (1) year of the date of declination of any part of a claim (logistics claims excluded).

G-7 052318 080118 083600172

IX. Jurisdiction, Choice of Forum

These Terms and Conditions of Contract shall be governed by and construed in accordance with the applicable laws of the United States or, alternatively, and depending on jurisdiction, the laws of the State of Nevada. The parties hereby submit to jurisdiction and venue in the United States Federal District Court of Nevada, or as applicable depending upon jurisdiction, the County Circuit Court in Clark County, Nevada.

X. Advanced Warehousing/Temporary Storage/Long Term Storage

All terms and conditions relative to Advanced Warehousing/Temporary Storage/Long Term Storage are contained in separate agreements titled "Storage Agreement". In the event that a Storage Agreement is not executed between the parties, the following shall apply with respect to GES' liability for Customer's Goods. The responsibility of GES with respect to Customer's Goods is limited to the exercise of ordinary care and diligence in handling and storing of Customer's Goods. GES shall be liable only for loss or damage to Goods caused by GES' sole negligence. GES' liability is limited to \$.60 (USD) per pound with a maximum liability of \$100.00 (USD) per container, or \$1,500.00 (USD) per shipment whichever is less. In case of partial loss or damage, the maximum liability shall be prorated based on weight. GES is not responsible for any loss or damage to Goods caused by, but not limited to fire, theft, the elements, vandalism, moisture, vermin, mechanical breakdown or failure, freezing or changes in temperature, as well as any other causes beyond GES' immediate control. GES is not responsible for the marring, scratching or breakage of glass or other fragile items. GES is not liable for the mechanical functions of instruments or appliances even if such articles are packed or unpacked by GES. In no event shall GES be liable for special, incidental, indirect or consequential damages, including business loss of any kind, resulting from any damage to or loss of the Goods or from any act or failure to act. Customer pays storage fees or costs for advance warehousing for use of the space only. There is no guarantee of security or representations made by GES as to appropriateness of the conditions for Customer's Goods. The risk of loss remains Customer's alone and GES recommends the Customer carry and maintain insurance in amounts sufficient to cover its risk.

XI. Personal Data

Customer consents to GES' use of personal information ("PI") that GES receives from Customer in any manner in connection with the Show as follows: (a) GES retains PI of Customer's primary contacts (including name and email) on an ongoing basis to better serve Customer's future event needs until either GES' Privacy Policy requires deletion or Customer instructs GES to delete it; (b) GES' payment card processor stores credit card information through its expiration date for Customer's convenience, unless Customer instructs GES to delete it sooner; and (c) other uses set forth in GES' Privacy Policy published at <http://www.ges.com/us/legal/privacy-policy>. GES is Privacy Shield certified and protects PI with technical, organizational and other safeguards in conformity with applicable data protection laws including, without limitation, privacy laws of European Union member states. Customers may opt-out of future electronic communications from GES using the contact information provided in GES' Privacy Policy.

Payment Policy

Payment for Services: GES requires payment in full at the time services are ordered. Further, GES requires that you provide a credit card authorization with your initial order. For your convenience, we will use the credit card authorization information that you enter on the website to charge your account for services, which may include labor, material handling or any applicable fuel or energy surcharge.

Discount Prices: To qualify for discount pricing, orders must be received with payment on or before the discount deadline date.

Method of Payment: GES accepts MasterCard, Visa, American Express via this website.

Third Party Billing: Each exhibiting firm is ultimately responsible for all charges incurred on its behalf. GES reserves the right to institute collection action against the exhibitor if the authorized third party does not pay.

Tax Exempt: If you are tax exempt in the state in which you will be exhibiting, you must provide a Sales Tax Exemption Certificate for that state. Please send the above information to the GES office for this show. Taxes vary by location and will be added to your invoice, if you do not submit your tax exempt certificate prior to the deadline date.

Adjustments and Cancellations: No adjustments to invoices will be made after the close of the show. Please refer to the individual forms for labor, etc. for cancellation fees. All orders cancelled by the Exhibitor or due to the cancellation of an event or their non-participation may be subject to cancellation fees equal to 50% - 100% of the total order based upon the status of move-in, work performed and/or GES set-up costs or expenses. A minimum non-refundable deposit of \$25.00 will be applied toward the invoice, unless there is a cancellation of your order. Additionally, GES retains the right to implement/assess a fuel or energy surcharge on all services as necessary based upon market conditions.

If you have any questions regarding our payment policy, please call GES National Servicer[®] at 800.475.2098 or visit the GES Servicer[®] at the show.

You may choose to pay by credit card, check or bank wire transfer; however, we require your credit card charge authorization to be on file with GES even if you are paying by check or bank wire transfer. You are responsible for any wire transfer bank processing fees.

All balances must be paid upon conclusion of the event. You agree to late fees up to 1.5% per month on any balance not paid at the conclusion of the event, or balance left without appropriate credit card on file.

For your convenience, we will use the credit card authorization to charge your credit card for any additional amounts ordered by your representative or services rendered to your company for this event.

GES will charge a convenience fee for each request to reprocess payment to an alternate credit card in order to cover incremental processing costs. An alternate credit card is a credit card different than the one used to process your initial payment in accordance with GES payment policy. The convenience fee will be quoted at the time your request is made to reprocess payment. The convenience fee will be added to your account balance and settled utilizing the new credit card provided.

GES requires the highest standards of integrity from all its employees. Please call our confidential Always Honest hotline at 866.225.8230 to report fraudulent or unethical behavior.

080118 083600172

G-7 052318

Operation of All Mechanical Lifts

All orders are governed by the GES Payment Policy and GES Terms & Conditions of Contract as specified in this Exhibitor Services Manual.

Natural Products Expo East / All Things Organic™ BioFach America
Baltimore Convention Center
September 13 - 15, 2018

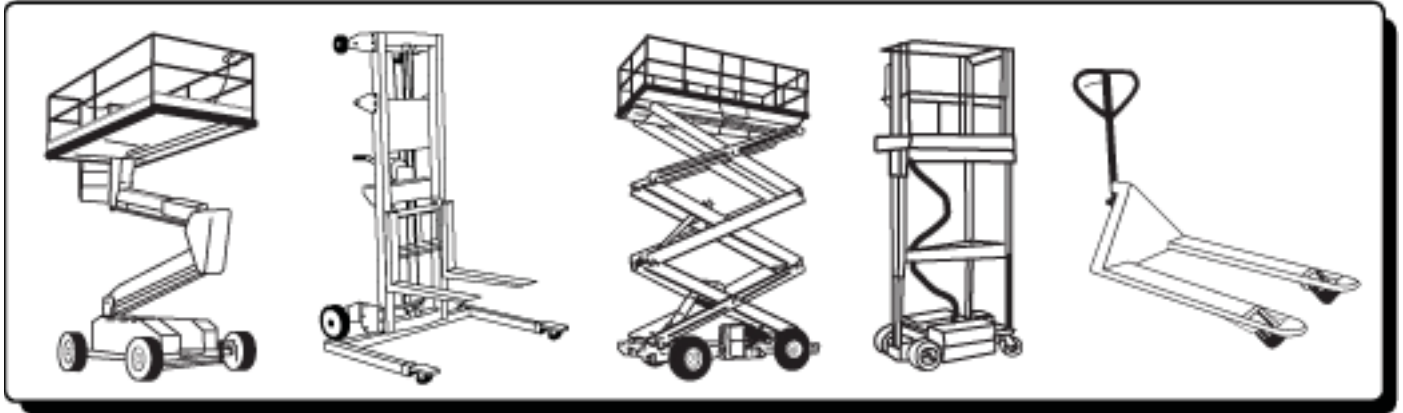

Attention all exhibitors:

- The operation or use of all motorized equipment for installation of booth structures or signs is not permitted by exhibitors or their appointed contractors.
- The operation or use of motorized or mechanical equipment, including mechanical scooters and carts, is not permitted by exhibitors or their appointed contractors for material handling. The use or prohibition of motorized scooters is controlled by and subject to the facility's rules, regulations and guidelines.
- All lifts, scooters, pallet jacks, dollies and manpower must be provided by the official service provider.
- Scooters and carts may only be used by the individuals to whom the scooters and carts are issued. GES equipment is for use by GES employees only. Please do not take it for your use.

Work Zone



- Customer acknowledges that the show site and surrounding areas are active work zones. Customer, its agents, employees and representatives are present on the show floor at their own risk.

Thank you for your complete cooperation.

080118 083600172

G-9 102617

Carpet

Standard

Standard is conventional filament nylon carpet that is re-used for pre-cut sizes and new for custom-cut orders.

Includes:

- Standard 100% recyclable color options include Blue Jay, Pepper, and Black
- Custom Cut includes 4 mil poly covering
- Available in pre-cut sizes
- Installation and pick-up at the close of the show
- Front edge taping



Black (41)



Blue (42)

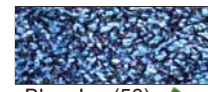

Blue Jay (56)



Gray (40)



Green (45)



Pepper (52)



Red (49)

Plush

Plush premium carpet is 100% recyclable. Same industry tradeshow performance standards as conventional carpet, but helps to reduce the volume of excess materials from entering landfills.

Includes:

- Plush 100% recyclable carpet
- 4 mil poly covering for protection
- Anti-static treatment
- 3M Scotchgard™ protection
- Installation and pick-up at the close of the show
- Front edge taping



Cement (70)



Charcoal (71)



Cobalt (72)

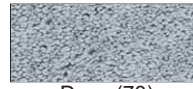

Dove (73)

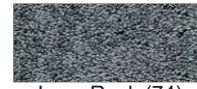

Lava Rock (74)

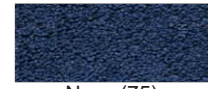

Navy (75)



Onyx (76)



Red (49)

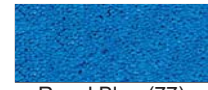

Royal Blue (77)



Silky Beige (78)



Silver (79)



Snow (80)

Ultra Plush

Ultra Plush premium carpet is 100% recyclable. Same industry tradeshow performance standards as conventional carpet, but helps to reduce the volume of excess materials from entering landfills.

Includes:

- Ultra Plush 100% recyclable carpet
- 4 mil poly covering for protection
- Anti-static treatment
- 3M Scotchgard™ protection
- Installation and pick-up at the close of the show
- Front edge taping



Bisque (81)



Black (41)

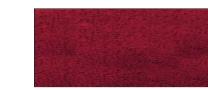

Cabernet (82)



Graphite (83)

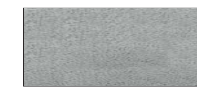

Iceberg (84)

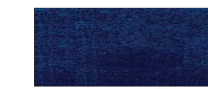

Midnight (85)



Seascape (86)



Sterling (87)



Teal (55)

 The leaf symbol indicates recyclable or eco-friendly materials, per manufacturer's specifications.

Colors may vary due to facility lighting, printing limitations and dye lot differences. Some items may not be available at all locations. See order form for details. Styles of items portrayed on this brochure may vary in some locations.

Carpet Order Form

All orders are governed by the GES Payment Policy and GES Terms & Conditions of Contract as specified in this Exhibitor Services Manual.

Natural Products Expo East / All Things Organic™ BioFach America
 Baltimore Convention Center
 September 13 - 15, 2018

Discount Deadline Date:
 August 20, 2018

Company Name _____ Email _____ Phone Number _____ Booth Number _____



Easy Ordering Tips:

- All prices include delivery, rental, and removal.
- Return your orders three (3) weeks before show move-in to ensure availability. At show site color options and grades may not be available and substitutions might be necessary.
- Do you have a booth larger than 300 sq. ft., an island or peninsula? Order Custom-Cut carpet! (Minimum 100 sq. ft. order required.)
- All Custom-Cut Carpet includes Carpet Plastic Covering.

Carpet

Standard Color Options

(Gray will be provided if no color is indicated below)



Plush Color Options

(Dove will be provided if no color is indicated below)

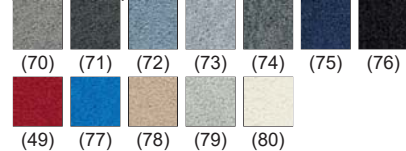

Ultra Plush Color Options

(Iceberg will be provided if no color is indicated below)



Item Code	Description	Color Code	Discount (\$)	Regular (\$)	Qty	Tax %	Total
5001	Pre-Cut Standard Carpet 10'x10'		185.00	237.00		6.0	\$
5002	Pre-Cut Standard Carpet 10'x20'		369.00	473.25		6.0	\$
5003	Pre-Cut Standard Carpet 10'x30'		553.25	709.50		6.0	\$
5004	Pre-Cut Standard Carpet 10'x15'		277.25	355.50		6.0	\$
5015	Pre-Cut Standard Carpet 8'x10'		147.75	189.25		6.0	\$
5018	Pre-Cut Standard Carpet 8'x20'		295.50	378.25		6.0	\$
5019	Pre-Cut Standard Carpet 8'x30'		443.25	567.50		6.0	\$

Calculate Sq. Ft. = Width _____ X Length _____ = _____ Total Sq. Ft.

Item Code	Description	Color Code	Discount (\$)	Regular (\$)	Sq. Ft.	Tax %	Total
5000	Standard Carpet Custom-Cut, Per Sq.Ft.		2.76	3.54		6.0	\$
5006	Plush Carpet Custom-Cut, Per Sq.Ft.		3.38	4.34		6.0	\$
5007	Ultra Plush Carpet Custom-Cut, Per Sq.Ft.		4.05	5.20		6.0	\$
Item Code	Description		Discount (\$)	Regular (\$)	Sq. Ft.	Tax %	Total
500400	Carpet Padding, 1/2" Thick, Per Sq.Ft.		0.70	0.91		6.0	\$
Item Code	Description		Discount (\$)	Regular (\$)	Sq. Ft.	Tax %	Total
500410	Carpet Plastic Covering, Per Sq.Ft.		0.38	0.50		6.0	\$

Electrical or Utilities Under Carpet?

Yes No

Total and Sign: Return to Fax: (866) 329-1437 • International Fax: (702) 263-1520

Please Sign

X

Authorized Signature

Authorized Name - Please Print

Date

I agree in placing this order that I have accepted GES Payment Policy and GES Terms & Conditions of Contract, including authorization for GES to retain personal information to better serve my need for GES services at future events.

Total Payment Enclosed

\$

Cancellation Policy: Custom Size Booth Carpet cancelled after being cut will be charged **100%**. All other carpet cancelled will be charged 50% of original price after move-in begins and **100%** of original price after installation.

Chat with us <http://www.ges.com/chat>



Carpet Package Order Form

All orders are governed by the GES Payment Policy and GES Terms & Conditions of Contract as specified in this Exhibitor Services Manual.

Natural Products Expo East / All Things Organic™ BioFach America
 Baltimore Convention Center
 September 13 - 15, 2018

Discount Deadline Date:
 August 20, 2018

Company Name _____ Email _____ Phone Number _____ Booth Number _____



Easy Ordering Tips:

- All prices include delivery, rental, and removal.
- Return your orders three (3) weeks before show move-in to ensure availability. At show site some colors and grades may not be available and substitutions might be necessary.
- A minimum of 100 sq. ft. is required for all custom-cut carpet package orders.
- All Carpet Packages Include 10% Off: 1/2in. Thick Padding, Visqueen and Cleaning.

Carpet Packages

Standard Color Options

(Gray will be provided if no color is indicated below)

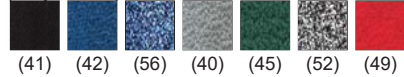

Plush Color Options

(Dove will be provided if no color is indicated below)

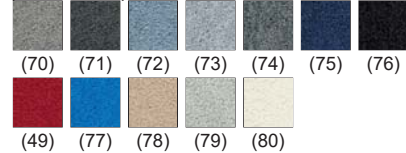

Ultra Plush Color Options

(Iceberg will be provided if no color is indicated below)

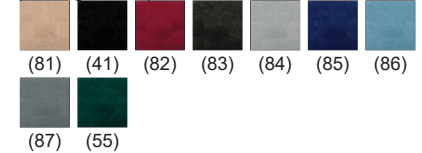

Item Code	Description	Color Code	Discount (\$)	Regular (\$)	Sq. Ft.	Tax %	Total
400021	Standard Carpet Package, Per Sq.Ft.		4.17	5.36		6.0	\$
400022	Plush Carpet Package, Per Sq.Ft.		4.73	6.08		6.0	\$
400023	Ultra Plush Carpet Package, Per Sq.Ft.		5.33	6.85		6.0	\$

Electrical or Utilities Under Carpet?

Yes No



- Save money by pre-ordering labor for installation for stairs, platforms, risers or meeting rooms.
- Return your orders before the discount deadline to receive the best price.

Total and Sign: Return to Fax: (866) 329-1437 • International Fax: (702) 263-1520

Please Sign

X

 Authorized Signature

 Authorized Name - Please Print Date

I agree in placing this order that I have accepted GES Payment Policy and GES Terms & Conditions of Contract, including authorization for GES to retain personal information to better serve my need for GES services at future events.

Total Payment Enclosed \$ _____

Cancellation Policy: Custom Size Booth Carpet cancelled after being cut will be charged **100%**. All other carpet cancelled will be charged **50%** of original price after move-in begins and **100%** of original price after installation.

083600172

080118

C-2 072718



Furniture and Accessories

Chairs



300050 - Chair, Plastic Contour, Black



300052 - Padded Chair



300053 - Padded Stool

Tables



300059 - Table, Starbase, 30" Diameter x 40" High



300058 - Table, Starbase, 40" Diameter x 30" High

Skirted Tables



3004 - Table 4', Skirted 4 Sides, 24" x 30" High



3006 - Table 6', Skirted 3 Sides, 24" x 30" High



3008 - Table 8', Skirted 3 Sides, 24" x 30" High

Table Skirt Colors



Beige (54)

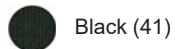

Black (41)



Blue (42)



Gold (46)

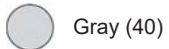

Gray (40)



Green (45)



Red (49)



White (50)

Colors may vary due to facility lighting, printing limitations and dye lot differences. Some items may not be available at all locations. See order form for details. Styles of items portrayed on this brochure may vary in some locations.

Furniture and Accessories

Display Furniture



Full View



Half View



Quarter View



Vertical

Accessories



300124 - Aisle Stanchion Chain, Plastic, Per Foot



300123 - Aisle Stanchion, without Chain



300103 - Aluminum Easel



300111 - Bag Stand



300102 - Coat Rack



300104 - Garment Rack



300106 - Literature Rack



300201 - Pegboard, White, 4'x8'



300107 - Refrigerator



300120 - Sign Holder, Bell Base



300108 - Sign Holder, Chrome, 22"x28"



300211 - Tackboard



300112 - Ticket Tumbler, Small, Table Top



300113 - Wastebasket



300118 - Waterfall Stand

Colors may vary due to facility lighting, printing limitations and dye lot differences. Some items may not be available at all locations. See order form for details. Styles of items portrayed on this brochure may vary in some locations.

Furniture and Accessories Order Form

All orders are governed by the GES Payment Policy and GES Terms & Conditions of Contract as specified in this Exhibitor Services Manual.

Natural Products Expo East / All Things Organic™ BioFach America
 Baltimore Convention Center
 September 13 - 15, 2018

Discount Deadline Date:
 August 20, 2018

Company Name _____ Email _____ Phone Number _____ Booth Number _____



Easy Ordering Tips:

- All prices include delivery, rental, and removal.
- Return your orders three (3) weeks before show move-in to ensure availability. At show site some items may not be available and substitutions might be necessary.
- Enjoy a fast and easy ordering experience online with Espresso:
<http://e.ges.com/083600172/BoothFurnishingsRental/esm>

Furniture and Accessories

Skirt and Drape Color Options

(Gray will be provided if no color is indicated below)



Chairs

Item Code	Description	Discount (\$)	Regular (\$)	Qty	Tax %	Total
300050	Chair, Plastic Contour, Black	59.00	75.50		6.0	\$
300052	Padded Chair	87.50	112.25		6.0	\$
300053	Padded Stool	86.75	111.25		6.0	\$

Tables

Item Code	Description	Discount (\$)	Regular (\$)	Qty	Tax %	Total
300059	Table, Starbase, 30" Diameter x 40" High	260.00	363.50		6.0	\$
300058	Table, Starbase, 40" Diameter x 30" High	260.00	363.50		6.0	\$

Skirted Tables

Item Code	Description	Color Code	Discount (\$)	Regular (\$)	Qty	Tax %	Total
3004	Table 4', Skirted 4 Sides, 24" x 30" High		130.50	167.25		6.0	\$
3006	Table 6', Skirted 3 Sides, 24" x 30" High		157.75	202.50		6.0	\$
3008	Table 8', Skirted 3 Sides, 24" x 30" High		195.75	251.00		6.0	\$
3007	Table, Skirt 4th Side		38.50	49.50		6.0	\$

↳ Select size: 6' Table _____ 8' Table _____

Unskirted Tables

Item Code	Description	Discount (\$)	Regular (\$)	Qty	Tax %	Total
300400	Table 4', Unskirted, 24" x 30" High	104.50	134.00		6.0	\$
300600	Table 6', Unskirted, 24" x 30" High	126.25	162.00		6.0	\$
300800	Table 8', Unskirted, 24" x 30" High	156.50	200.50		6.0	\$

Skirted Counters

Item Code	Description	Color Code	Discount (\$)	Regular (\$)	Qty	Tax %	Total
3014	Counter 4', Skirted 4 Sides, 24" x 42" High		157.75	202.50		6.0	\$
3016	Counter 6', Skirted 3 Sides, 24" x 42" High		192.75	247.00		6.0	\$
3018	Counter 8', Skirted 3 Sides, 24" x 42" High		223.50	286.50		6.0	\$
3017	Counter, Skirt 4th Side		49.00	62.75		6.0	\$

↳ Select size: 6' Counter _____ 8' Counter _____

Unskirted Counter

Item Code	Description	Discount (\$)	Regular (\$)	Qty	Tax %	Total
301400	Counter 4', Unskirted, 24" x 42" High	126.25	162.00		6.0	\$

083600172

080118

A-1 032618

Form Continues on Next Page



Furniture and Accessories Order Form

All orders are governed by the GES Payment Policy and GES Terms & Conditions of Contract as specified in this Exhibitor Services Manual.

Discount Deadline Date:
August 20, 2018

Company Name	Email	Phone Number	Booth Number
301600	Counter 6', Unskirted, 24" x 42" High	154.25 197.75	6.0 \$
301800	Counter 8', Unskirted, 24" x 42" High	178.75 229.25	6.0 \$

Risers

Item Code	Description	Discount (\$)	Regular (\$)	Qty	Tax %	Total
300193	Riser 4', Double Tier, 48"x8"x16" High	63.75	89.25		6.0	\$
300191	Riser 4', Single Tier, 48"x8"x8" High	61.25	78.75		6.0	\$
300194	Riser 6', Double Tier, 72"x8"x16" High	82.50	115.50		6.0	\$
300192	Riser 6', Single Tier, 72"x8"x8" High	81.25	104.00		6.0	\$

Custom Booth Drape

Item Code	Description	Color Code	Discount (\$)	Regular (\$)	Qty	Tax %	Total
3001	Drape, 3' High, Per Foot, 4' Minimum		14.55	18.65		6.0	\$
3002	Drape, 8' High, Per Foot, 4' Minimum		18.60	24.15		6.0	\$
3019	Drape, 12' High, Per Foot		23.25	29.75		6.0	\$

Display Furniture

Item Code	Description	Discount (\$)	Regular (\$)	Qty	Tax %	Total
300073	Display Case 4', Corner View	673.25	941.75		6.0	\$
300074	Display Case 4', Full View	594.75	762.75		6.0	\$
300075	Display Case 4', Half View	575.25	737.50		6.0	\$
300076	Display Case 4', Quarter View	575.25	737.50		6.0	\$
300078	Display Case 5', Full View	654.00	914.50		6.0	\$
300079	Display Case 5', Half View	654.00	914.50		6.0	\$
300080	Display Case 5', Quarter View	654.00	914.50		6.0	\$
300082	Display Case 6', Full View	696.00	892.25		6.0	\$
300083	Display Case 6', Half View	645.50	827.50		6.0	\$
300084	Display Case 6', Quarter View	645.50	827.50		6.0	\$
300088	Display Case 7', Vertical	879.00	1,229.25		6.0	\$

Accessories

Item Code	Description	Discount (\$)	Regular (\$)	Qty	Tax %	Total
300218	4' Table Top Sneeze Guard	526.75	675.25		6.0	\$
300124	Aisle Stanchion Chain, Plastic, Per Foot	5.60	7.80		6.0	\$
300123	Aisle Stanchion, without Chain	54.75	76.75		6.0	\$
300103	Aluminum Easel	55.75	71.25		6.0	\$
300111	Bag Stand	76.25	97.75		6.0	\$
300102	Coat Rack	40.25	51.75		6.0	\$
300104	Garment Rack	101.25	141.75		6.0	\$
300106	Literature Rack	176.75	226.50		6.0	\$
300201	Pegboard, White, 4'x8'	176.75	226.50		6.0	\$
↳ Select alignment: Horizontal <input type="checkbox"/> Vertical <input type="checkbox"/>						
300107	Refrigerator	419.50	538.00		6.0	\$
300131	Security Cage, Large, without Lock	561.50	785.25		6.0	\$
300132	Security Cage, Small, without Lock	373.00	521.75		6.0	\$
300120	Sign Holder, Bell Base	84.50	108.50		6.0	\$
300108	Sign Holder, Chrome, 22"x28"	84.50	108.50		6.0	\$

A-1 032618 080118 083600172



Furniture and Accessories Order Form

All orders are governed by the GES Payment Policy and GES Terms & Conditions of Contract as specified in this Exhibitor Services Manual.

Discount Deadline Date:
August 20, 2018

Company Name _____ Email _____ Phone Number _____ Booth Number _____

Accessories

300211	Tackboard	176.50	226.25		6.0	\$
	Select alignment: Horizontal _____ Vertical _____					
300112	Ticket Tumbler, Small, Table Top	159.00	222.25		6.0	\$
300113	Wastebasket	22.30	28.50		6.0	\$
300118	Waterfall Stand	101.25	141.75		6.0	\$

Electrical Outlets Not Included

Need power for that display case or refrigerator in your booth? Order electrical outlets separately for your booth space through the electrical service provider.

Total and Sign: Return to Fax: (866) 329-1437 • International Fax: (702) 263-1520

Please Sign _____
Authorized Signature

Authorized Name - Please Print

Date

I agree in placing this order that I have accepted GES Payment Policy and GES Terms & Conditions of Contract, including authorization for GES to retain personal information to better serve my need for GES services at future events.

Total Payment Enclosed

Cancellation Policy: Items cancelled will be charged **50%** of original price after move-in begins and **100%** of original price after installation.

080118 083600172

A-1 032618



Furniture Package Order Form

All orders are governed by the GES Payment Policy and GES Terms & Conditions of Contract as specified in this Exhibitor Services Manual.

Natural Products Expo East / All Things Organic™ BioFach America
 Baltimore Convention Center
 September 13 - 15, 2018

Discount Deadline Date:
 August 20, 2018

Company Name _____ Email _____ Phone Number _____ Booth Number _____



Easy Ordering Tips:

- Furniture Packages offer significant savings and convenience.
- All prices include delivery, rental, and removal.
- Return your orders three (3) weeks before show move-in to ensure availability. At show site some items may not be available and substitutions might be necessary.

Furniture Package



Furniture Package 1

Item Code	Description	Color Code	Discount (\$)	Regular (\$)	Qty	Tax %	Total
400015	Furniture Package 1 with 10'x10' Standard Carpet		434.75	557.25		6.0	\$
	↳ Includes: (2) Black Plastic Contour Chairs, (1) 6' Skirted Table 24"X30", (1) Wastebasket, (1) 10' x 10' Booth Carpet.						
400019	Furniture Package 1 with 10'x20' Standard Carpet		600.50	768.75		6.0	\$
	↳ Includes: (4) Black Plastic Contour Chairs, (2) 6' Skirted Table 24"X30", (2) Wastebasket, (1) 10' x 20' Booth Carpet.						
400294	Furniture Package 1 with 8'x10' Standard Carpet		401.25	513.75		6.0	\$
400284	Furniture Package 1 with 8'x20' Standard Carpet		534.25	684.00		6.0	\$

Skirt Color Options

(Gray will be provided if no color is indicated.)



13oz Carpet Color Options

(Gray will be provided if no color is indicated below)

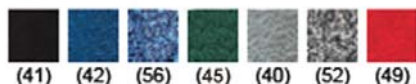

Electrical or Utilities Under Carpet?

Yes No

Total and Sign: Return to Fax: (866) 329-1437 • International Fax: (702) 263-1520

Please Sign

X

Authorized Signature

Authorized Name - Please Print

Date

I agree in placing this order that I have accepted GES Payment Policy and GES Terms & Conditions of Contract, including authorization for GES to retain personal information to better serve my need for GES services at future events.

Total Payment Enclosed

\$

Cancellation Policy: Items cancelled will be charged **50%** of original price after move-in begins and **100%** of original price after installation.

083600172

080118

A-2 081717 cstm



Sneeze Guard Shield Order Form

All orders are governed by the GES Payment Policy and GES Terms & Conditions of Contract as specified in this Exhibitor Services Manual.

Natural Products Expo East / All Things Organic™ BioFach America
 Baltimore Convention Center
 September 13 - 15, 2018

Discount Deadline Date:
 August 20, 2018

Company Name _____ Email _____ Phone Number _____ Booth Number _____



Easy Ordering Tips:

- Want an easier way? Submit your order online: <https://e.ges.com/083600172/accessories/esm>

Item Code	Description	Discount (\$)	Regular (\$)	Qty	Tax %	Total
300218	4' Table Top Sneeze Guard	526.75	675.25		6.0	\$

Total and Sign: Return to Fax: (866) 329-1437 • International Fax: (702) 263-1520

Please Sign

X

Authorized Signature _____

Authorized Name - Please Print _____

Date _____

I agree in placing this order that I have accepted GES Payment Policy and GES Terms & Conditions of Contract, including authorization for GES to retain personal information to better serve my need for GES services at future events.

Total Payment Enclosed

\$ _____

Cancellation Policy: Items cancelled will be charged 50% of original price after move-in begins and 100% of original price after installation.

A-3 050416 Cstm 080118 083600172



Specialty Furniture

Seating - Sofas and Loveseats



305226 - Baja Loveseat, 61"L 30.5"D 28"H



 305312 - Banquette, Full, w/ Electrical Charging Outlet, 72"RND 51"H



305180 - Fairfax Sofa, White Vinyl/ Brushed Metal, 62"L 26"D 30"H



305049 - Hopi Loveseat, Gray Linen, 48"L 25"D 34"H



305321 - Key Largo Loveseat, Black Fabric, 57"L 35"D 34"H



305322 - Key Largo Sofa, Black Fabric, 79"L 35"D 34"H



305262 - Loveseat, Naples, Black Vinyl, 62"L 30"D 28"H



305104 - Munich Armless Loveseat, 45"L 27"D 28.5"H



305106 - Munich Sectional, 3 Pc., 93.5"L 27"D 28.5"H



305364 - Naples Loveseat, Powered Black Vinyl, 62"L 30"D 28"H



305362 - Naples Sofa, Powered Black Vinyl, 87"L 30"D 28"H



305217 - Roma Sofa, Powered White Vinyl, 78"L 31"D 33"H



305120 - Sectional, South Beach, 3 pc., Platinum, 152"L 40"D 33"H



305236 - Sofa, Allegro, Blue Fabric, 73"L 34.5"D 29.5"H



305261 - Sofa, Naples, Black Vinyl, 87"L 30"D 28"H

Colors may vary due to facility lighting, printing limitations and dye lot differences. Some items may not be available at all locations. USB power adapters/charging accessories are not included with any powered furniture. See order form for details. Styles of items portrayed on this brochure may vary in some locations.

Specialty Furniture



305119 - Sofa, South Beach, Platinum Suede, 69"L 29"D 33"H



305268 - Sofa, Tangiers, 78"L 37"D 36"H



305240 - Tangiers Loveseat, 57.5"L 37"D 37"H

Seating - Club Chairs



305225 - Baja Chair, 36"L 30.5"D 28"H



305235 - Chair, Allegro, Blue Fabric, 36"L 34.5"D 29.5"H



305072 - Chair, Barcelona, Black, 30"L 31"D 35"H



305073 - Chair, Barcelona, White, 30"L 30"D 31"H



305263 - Chair, Naples, Black Vinyl, 36"L 30"D 28"H



305269 - Chair, Tangiers, 34"L 37"D 36"H



305070 - Chair, Tub, Key West, Black, 31"L 31"D 31"H



305320 - Key Largo Chair, Black Fabric, 35"L 35"D 34"H



305102 - Munich Corner Chair, 26"L 27"D 28.5"H



305363 - Naples Chair, Powered Black Vinyl, 36"L 30"D 28"H



305222 - Roma Chair, Powered White Vinyl, 37"L 31"D 33"H

Seating - Chairs



305152 - Chair, Alta, Guest, 25"L 20"D 34"H



305041 - Chair, Berlin, Black/White, 18"L 22"D 32"H



305042 - Chair, Berlin, Red/White, 18"L 22"D 32"H



305110 - Chair, Brewer, Black, 20"L 20"D 32"H



305260 - Chair, Christopher, White Vinyl w/Chrome, 17"L 19"D 35"H



305285 - Chair, Duet Stack, Black/Chrome, 23"L 21"D 33"H



305232 - Chair, Fusion, Red/White, 19"L 21"D 32"H



305271 - Chair, La Brea Swivel, Charcoal Gray Fabric, 35"L 27"D 40"D



305270 - Chair, Madden Arm, Lt. Gray Vinyl, 27"L 32"D 33"H



305284 - Chair, Rustique Arm, Gunmetal, 20"L 18"D 31"H



305272 - Chair, Swanson Swivel, White Vinyl, 28"L 25"D 18"H



305250 - Chair, Wendy, Clear Acrylic, 15"L 20"D 36"H



305178 - Fairfax Arm Chair, White Vinyl/Brushed Metal, 27"L 26"D 30"H



305047 - Hopi Chair, Gray Linen, 21"L 25"D 34"H

Colors may vary due to facility lighting, printing limitations and dye lot differences. Some items may not be available at all locations. USB power adapters/charging accessories are not included with any powered furniture. See order form for details. Styles of items portrayed on this brochure may vary in some locations.

Specialty Furniture



305442 - Laguna Chair, 18"L 19"D 34"H



305420 - Malba Chair, Gray, 20"L 20"D 32"H



305421 - Malba Chair, Green, 20"L 20"D 32"H



305103 - Munich Armless Chair, 22.5"L 27"D 28.5"H



305300 - Razor Chair, White, 15.38"L 15.5"D 30.5"H



305441 - Zenith Chair, 19"L 22"D 32"H

Seating - Ottomans



305316 - Banquette, Quarter Curve Ottoman, 53"L 22"D 18"H



305057 - Beverly Bench Ottoman, Black Vinyl, 60"L 20"D 18"H



305058 - Beverly Bench Ottoman, Brown Fabric, 60"L 20"D 18"H



305059 - Beverly Bench Ottoman, Gray Fabric, 60"L 20"D 18"H



305060 - Beverly Bench Ottoman, Linene Fabric, 60"L 20"D 18"H



305061 - Beverly Bench Ottoman, Ocean Blue Fabric, 60"L 20"D 18"H



305063 - Beverly Bench Ottoman, Red Fabric, 60"L 20"D 18"H



305064 - Beverly Bench Ottoman, White Vinyl, 60"L 20"D 18"H



305096 - Endless Curved Ottoman, Black, 60.5"L 37.5"D 15"H



305097 - Endless Curved Ottoman, White, 60.5"L 37.5"D 15"H



305280 - Ottoman, Endless Square, Black, 34"L 34"D 15"H



305279 - Ottoman, Endless Square, White, 34"L 34"D 15"H



305086 - Ottoman, Half Bench, White Vinyl, 39"L 22"D 18"H



305360 - Ottoman, Marche Swivel, Blue Fabric, 17"L 17"D 18"H



305352 - Ottoman, Marche Swivel, Gray Fabric, 17"L 17"D 18"H



305353 - Ottoman, Marche Swivel, Linen Fabric, 17"L 17"D 18"H



305358 - Ottoman, Marche Swivel, Meadow Green, 17"L 17"D 18"H



305359 - Ottoman, Marche Swivel, Pear Yellow Fabric, 17"L 17"D 18"H



305357 - Ottoman, Marche Swivel, Plum Fabric, 17"L 17"D 18"H



305354 - Ottoman, Marche Swivel, Raspberry Fabric, 17"L 17"D 18"H



305355 - Ottoman, Marche Swivel, Red Fabric, 17"L 17"D 18"H



305356 - Ottoman, Marche Swivel, Rose Quartz Fabric, 17"L 17"D 18"H



305351 - Ottoman, Marche Swivel, White Vinyl, 17"L 17"D 18"H



305092 - Ottoman, South Beach, Wedge, Platinum, 25"L 31"D 18"H

Colors may vary due to facility lighting, printing limitations and dye lot differences. Some items may not be available at all locations. USB power adapters/charging accessories are not included with any powered furniture. See order form for details. Styles of items portrayed on this brochure may vary in some locations.

Specialty Furniture



305251 - Ottoman, Vibe Cube, Black Vinyl, 18"L 18"D 18"H



305246 - Ottoman, Vibe Cube, Blue, Vinyl, 18"L 18"D 18"H



305242 - Ottoman, Vibe Cube, Champagne, Vinyl, 18"L 18"D 18"H



305243 - Ottoman, Vibe Cube, Gold/Bronze, Vinyl, 18"L 18"D 18"H



305241 - Ottoman, Vibe Cube, Green, Vinyl, 18"L 18"D 18"H



305248 - Ottoman, Vibe Cube, Orange, Vinyl, 18"L 18"D 18"H



305244 - Ottoman, Vibe Cube, Pink, Vinyl, 18"L 18"D 18"H



305239 - Ottoman, Vibe Cube, Purple Vinyl, 18"L 18"D 18"H



305245 - Ottoman, Vibe Cube, Red, Vinyl, 18"L 18"D 18"H



305238 - Ottoman, Vibe Cube, Silver Vinyl, 18"L 18"D 18"H



305237 - Ottoman, Vibe Cube, Steel Blue Vinyl, 18"L 18"D 18"H



305249 - Ottoman, Vibe Cube, White Vinyl, 18"L 18"D 18"H



305247 - Ottoman, Vibe Cube, Yellow, Vinyl, 18"L 18"D 18"H



305111 - Sally Ottoman/Stool, White 12"L 12"D 17"H

Seating - Office and Utility Seating



305126 - Chair, Altura Task, 25"L 26"D 21"H



305325 - Chair, Executive, Black, 25"L 24"D 48"H



305305 - Chair, Executive, Pro, White, 27.5"L 27.5"D 45.7"H



305068 - Meeting Chair, Espresso Vinyl, 25.5"L 23.5"D 34"H



305069 - Meeting Chair, Taupe Fabric, 25.5"L 23.5"D 34"H



305309 - Meeting Chair, White Vinyl, 25.5"L 23.5"D 34"H



305313 - Pro Executive Guest Chair, Black Vinyl, 24"L 22"D 36"H



305307 - Pro Executive Mid Back Chair, Black Vinyl, 24"L 22"D 40"H



305308 - Pro Executive Mid Back Chair, White, 24"L 22"D 40"H

Colors may vary due to facility lighting, printing limitations and dye lot differences. Some items may not be available at all locations. USB power adapters/charging accessories are not included with any powered furniture. See order form for details. Styles of items portrayed on this brochure may vary in some locations.

Specialty Furniture

Seating - Barstools



305370 - Apex Barstool, Black Vinyl, 21"L 21"D 33"H



305371 - Apex Barstool, Blue Ultra Suede, 21"L 21"D 33"H



305372 - Apex Barstool, Red Vinyl, 21"L 21"D 33"H



305373 - Apex Barstool, White Vinyl, 21"L 21"D 33"H



305012 - Barstool, Banana, Black, 21"L 22"D 30"H



305013 - Barstool, Banana, White, 21"L 22"D 30"H



305289 - Barstool, Lift, Chrome/Black Seat, 15" Round 23-33.5"H



305292 - Barstool, Lift, Chrome/Gray Seat, 15" Round 23-33.5"H



305291 - Barstool, Lift, Chrome/Red Seat, 15" Round 23-33.5"H



305290 - Barstool, Lift, Chrome/White Seat, 15" Round 23-33.5"H



305009 - Barstool, Oslo, Blue, 17"L 20"D 30"H



305008 - Barstool, Oslo, White, 17"L 20"D 30"H



305288 - Barstool, Rustique, Gunmetal, 13"L 13"D 30"D



305206 - Barstool, Shark Swivel, White/Chrome Base, 22"L 19"D 34"-44"H



305207 - Barstool, Zoey Swivel, White/Chrome Base, 15"Lx17"Dx31"-35"H



305259 - Christopher Barstool, 19"L 15"D 41"H



305443 - Laguna Barstool, Maple, Chrome, 18"L 20"D 47"H



305006 - Syntax Barstool, Chrome/Black, 23"L 19"D 43.25"H



305007 - Syntax Chair, Black/Chrome, 23"L 19"D 32.25"H



305440 - Zenith Barstool, 19"L 20"D 44"H



305208 - Zoey Barstool, Black, 15"L 16"D 30-34.75"H

Table Surface Colors



Maple



Graphite Nebula



Brushed Red

Tables - Cafe



305406 - 30" Round Madison Cafe Table w/ Standard Black Base, Gray Acajou



305426 - Cafe Table/Hydraulic Chrome Base, Liquid Steel Blue, 30"RND 29"



305084 - Café Table w/ Standard Black Base, 30"RND 29"H



305428 - Café Table/Black Base, Liquid Steel Blue, 30"RND 29"H



305067 - G30 Cafe Table, Powered White Top, 72"L 26"D 30"H



305429 - Madison Cafe Table/Hydraulic Base, 30"RND 29"H



305085 - Round Café Table w/ Hydraulic Base, 30"RND 29"H



305164 - Round Café Table w/ Standard Black Base, Graphite Nebula Top, 30"RND 29"H

Colors may vary due to facility lighting, printing limitations and dye lot differences. Some items may not be available at all locations. USB power adapters/charging accessories are not included with any powered furniture. See order form for details. Styles of items portrayed on this brochure may vary in some locations.

Specialty Furniture



305153 - Table, Cafe, Brushed Red/Hydraulic Chrome Base, 30" Round 29"H



305167 - Table, Cafe, Graphite/Black, 36" Round 29"H



305156 - Table, Cafe, Graphite/Hydraulic Chrome Base, 30" Round 29"H



305159 - Table, Cafe, Graphite/Hydraulic Chrome Base, 36" Round 29"H



305165 - Table, Cafe, Maple/Black, 30" Round 29"H



305168 - Table, Cafe, Maple/Black, 36" Round 29"H



305157 - Table, Cafe, Maple/Hydraulic Chrome Base, 30" Round 29"H



305160 - Table, Cafe, Maple/Hydraulic Chrome Base, 36" Round 29"H



305161 - Table, Cafe, Red/Black, 30" Round 29"H



305282 - Table, Cafe, Silver Texture/Black Base, 30" Round 29"H



305299 - Table, Cafe, Silver Textured Grain/Chrome Base, 30" Round 29"H



305283 - Table, Cafe, White Laminate/Black Base, 36" Round 29"H



305301 - Table, Cafe, White Laminate/Chrome Base, 36" Round 29"H

Tables - Bar



305315 - 30" Round Madison Bar Table w/ Hydraulic Base, Gray Acajou



305083 - Bar Table w/ Hydraulic Base, 30" RND 45"H



305082 - Bar Table w/ Standard Black Base, 30" RND 42"H



305425 - Bar Table/Hydraulic Chrome Base, Steel Blue, 30" RND 45"H



305405 - Madison Bar Table/Black Base, 30" RND 42"H



305162 - Rustique Square Metal Bar Table, 23.75" L 23.75" D 41.25"H



305139 - Table, Bar, Brushed Red/Hydraulic Chrome Base, 30" Round 45"H



305133 - Table, Bar, Graphite/Black, 30" Round 42"H



305136 - Table, Bar, Graphite/Black, 36" Round 42"H



305142 - Table, Bar, Graphite/Hydraulic Chrome Base, 30" Round 45"H



305145 - Table, Bar, Graphite/Hydraulic Chrome Base, 36" Round 45"H



305134 - Table, Bar, Maple/Black, 30" Round 42"H



305137 - Table, Bar, Maple/Black, 36" Round 42"H



305143 - Table, Bar, Maple/Hydraulic Chrome Base, 30" Round 45"H



305146 - Table, Bar, Maple/Hydraulic Chrome Base, 36" Round 45"H



305130 - Table, Bar, Red/Black, 30" Round 42"H



305286 - Table, Bar, Silver Textured Grain/Black Base, 30" Round 42"H



305302 - Table, Bar, Silver Textured Grain/Chrome Base, 30" Round 45"H



305287 - Table, Bar, White Laminate/Black Base, 36" Round 42"H



305303 - Table, Bar, White Laminate/Chrome Base, 36" Round 45"H



305030 - Ventura Communal Bar Table w/ Grommet Holes, Maple Top, 72.25" L 26.25" D 42"H

Colors may vary due to facility lighting, printing limitations and dye lot differences. Some items may not be available at all locations. USB power adapters/charging accessories are not included with any powered furniture. See order form for details. Styles of items portrayed on this brochure may vary in some locations.

Specialty Furniture



305032 - Ventura Communal Bar Table w/ Grommet Holes, White Top, 72.25"L 26.25"D 42"H

305031 - Ventura Communal Bar Table, Black Top, 72.25"L 26.25"D 42"H

305033 - Ventura Communal Bar Table, Maple Top, 72.25"L 26.25"D 42"H

305034 - Ventura Communal Bar Table, White Top, 72.25"L 26.25"D 42"H

305020 - Ventura Communal Black Bar Table, Powered, 72.25"L 26.25"D 42"H

305022 - Ventura Communal White Bar Table, Powered, 72.25"L 26.25"D 42"H

Tables - Cocktail



305430 - Alondra Cocktail Table, Glass, 47"L 24"D 16"H



305433 - Alondra Cocktail Table, Wood, Chrome, 47"L 24"D 17"H



305435 - Geo Cocktail Table, Wood, 47"L 24"D 17"H



305113 - Regis Table/Bench, 47"L 15.5"D 16"H



305188 - Sydney Powered Cocktail Table, Black, 48"L 26"D 18"H



305187 - Sydney Powered Cocktail Table, White, 48"L 26"D 18"H



305014 - Table, Cocktail, Geo, Chrome, 50"L 22"D 16"H



305210 - Table, Cocktail, Oliver, 47"L 27"D 19"H



305016 - Table, Cocktail, Silverado, 36" Round 17"H



305025 - Table, Cocktail, Sydney Black, 48"L 26"D 18"H



305024 - Table, Cocktail, Sydney White, 48"L 26"D 18"H

Colors may vary due to facility lighting, printing limitations and dye lot differences. Some items may not be available at all locations. USB power adapters/charging accessories are not included with any powered furniture. See order form for details. Styles of items portrayed on this brochure may vary in some locations.

Specialty Furniture

Tables - End Tables



305431 - Alondra End Table, Glass, 20"L 20"D 20"H



305432 - Alondra End Table, Wood, Chrome, 20"L 20"D 21"H



305254 - Edge Table, LED Lighted w/AC Plug, 20"L 20"D 20"H



305436 - Geo End Table, Wood, 20"L 20"D 21"H



305258 - Luna Pedestal, LED Lighted w/AC Plug, 16"L 16"D 20"H



305112 - Regis End Table, 16"L 15.5"D 16.5"H



305273 - Table, Aura, White Metal, 15" Round 22"H



305274 - Table, E, Wood, 21"L 15.5"D 27.5"H



305044 - Table, End, Geo, Chrome, 26"L 26"D 20"H



305211 - Table, End, Oliver, 22" Round 22"H



305046 - Table, End, Silverado, 24" Round 22"H



305050 - Table, End, Sydney, Black, 27"L 23"D 22"H



305048 - Table, End, Sydney, White, 27"L 23"D 22"H



305275 - Table, Timber, Wood, 16" Round 17"H

Conference Tables



305402 - 10' Madison Table, 120"L 48"D 29"H



305231 - 10' Table, Conf., Granite, 120"L 46"D 29"H



305400 - 5' Madison Table, 60"L 48"D 29"H



305230 - 6' Table, Conf., Granite, 72"L 36"D 29"H



305401 - 8' Madison Table, 96"L 60"D 29"H



305026 - 8' Table, Conf., Granite, 96"L 44"D 29"H



305001 - Atomic Table, 36"RND 30"H



305002 - Atomic Table, 42"RND 30"H

Colors may vary due to facility lighting, printing limitations and dye lot differences. Some items may not be available at all locations. USB power adapters/charging accessories are not included with any powered furniture. See order form for details. Styles of items portrayed on this brochure may vary in some locations.

Specialty Furniture



305410 - Madison Conference Table, 42"RND 29"H



305190 - Powered Conference Table Module, Black, 5"L 2.25"D 2"H



305175 - Table, Conf., Geo, Black, 42"L 42"D 29"H



305176 - Table, Conf., Geo, Black, 60"L 36"D 29"H



305173 - Table, Conf., Geo, Chrome, 42"L 42"D 29"H



305174 - Table, Conf., Geo, Chrome, 60"L 36"D 29"H



305027 - Table, Conf., Graphite, 42" Round 29"H



305293 - Table, Conf., Merlin, Gray Laminate/Black, 46"L 29"D 30"H



305281 - Table, Conf., White Laminate, 42" Round 29"H

Tables - Martini Bar



305004 - Table, Bar, Martini 3 pc., 100"L 100"D 47"H



305003 - Table, Bar, Martini, 50"L 50"D 47"H

Colors may vary due to facility lighting, printing limitations and dye lot differences. Some items may not be available at all locations. USB power adapters/charging accessories are not included with any powered furniture. See order form for details. Styles of items portrayed on this brochure may vary in some locations.

Specialty Furniture

Product Display



305415 - Madison Bookcase, 36"L 12"D 72"H



305297 - Pedestal, Powered Locking, Black, 24"L 24"D 36"H



305295 - Pedestal, Powered Locking, Black, 24"L 24"D 42"H



305298 - Pedestal, Powered Locking, White, 24"L 24"D 36"H



305296 - Pedestal, Powered Locking, White, 24"L 24"D 42"H



305045 - Posh Shelving, 36"L 18"D 72"H

Office and Utility Furniture



305294 - Desk, Writing/Work Table, White Laminate/White, 48"L 24"D 30"H



305416 - Madison Credenza, 60"L 20"D 29"H



305417 - Madison Executive Desk, 60"L 30"D 29"H



305129 - Tech 3 Drawer File Cabinet on Castors, Black, 16"L 20"D 28"H



 305128 - Tech Desk, Powered w/ 3 Drawer File Cabinet, Black Metal, 60"L 30"D 30"H



 305127 - Tech Desk, Powered, Black Metal, 60"L 30"D 30"H

Colors may vary due to facility lighting, printing limitations and dye lot differences. Some items may not be available at all locations. USB power adapters/charging accessories are not included with any powered furniture. See order form for details. Styles of items portrayed on this brochure may vary in some locations.

Specialty Furniture

Lamps



305204 - Lamp, Floor,
Mason, Silver, 18" Round
55"H



305205 - Lamp, Table,
Mason, Silver, 16" Round
26"H

Colors may vary due to facility lighting, printing limitations and dye lot differences. Some items may not be available at all locations. USB power adapters/charging accessories are not included with any powered furniture. See order form for details. Styles of items portrayed on this brochure may vary in some locations.

Specialty Furniture Order Form

All orders are governed by the GES Payment Policy and GES Terms & Conditions of Contract as specified in this Exhibitor Services Manual.

Natural Products Expo East / All Things Organic™ BioFach America
 Baltimore Convention Center
 September 13 - 15, 2018

Discount Deadline Date:
 August 20, 2018

Company Name _____ Email _____ Phone Number _____ Booth Number _____



Easy Ordering Tips:

- All prices include delivery, rental, and removal.
- Return your orders three (3) weeks before show move-in to ensure availability. At show site some items may not be available and substitutions might be necessary.
- USB power adapters/charging accessories are not included with any powered furniture. The adapters will not be available for separate rental. Please note: you are responsible for providing your own adapters/charging accessories. Electrical outlet is not included in price; please order separately. One 110V power source is required for each charging panel. Two charging units can be daisy chained together depending on booth layout. 10 AMP max per charging panel.
- Enjoy a fast and easy ordering experience online with Espresso:
<http://e.ges.com/083600172/BoothFurnishingsRental/esm>

Specialty Furniture

Seating - Sofas and Loveseats

Item Code	Description	Discount (\$)	Regular (\$)	Qty	Tax %	Total
305226	Baja Loveseat, 61"L 30.5"D 28"H	817.25	1,135.25		6.0	\$
305312	Banquette, Full, w/ Electrical Charging Outlet, 72"RND 51"H	2,218.75	3,075.25		6.0	\$
305180	Fairfax Sofa, White Vinyl/Brushed Metal, 62"L 26"D 30"H	780.25	1,083.50		6.0	\$
305049	Hopi Loveseat, Gray Linen, 48"L 25"D 34"H	304.50	423.00		6.0	\$
305321	Key Largo Loveseat, Black Fabric, 57"L 35"D 34"H	657.00	918.75		6.0	\$
305322	Key Largo Sofa, Black Fabric, 79"L 35"D 34"H	711.00	994.50		6.0	\$
305262	Loveseat, Naples, Black Vinyl, 62"L 30"D 28"H	468.75	655.75		6.0	\$
305104	Munich Armless Loveseat, 45"L 27"D 28.5"H	724.50	1,006.25		6.0	\$
305106	Munich Sectional, 3 Pc., 93.5"L 27"D 28.5"H	1,857.50	2,580.00		6.0	\$
305364	Naples Loveseat, Powered Black Vinyl, 62"L 30"D 28"H	1,184.75	1,657.00		6.0	\$
305362	Naples Sofa, Powered Black Vinyl, 87"L 30"D 28"H	1,355.25	1,895.50		6.0	\$
305217	Roma Sofa, Powered White Vinyl, 78"L 31"D 33"H	1,355.25	1,895.50		6.0	\$
305120	Sectional, South Beach, 3 pc., Platinum, 152"L 40"D 33"H	1,657.50	2,318.25		6.0	\$
305236	Sofa, Allegro, Blue Fabric, 73"L 34.5"D 29.5"H	797.25	1,115.00		6.0	\$
305261	Sofa, Naples, Black Vinyl, 87"L 30"D 28"H	589.75	824.75		6.0	\$
305119	Sofa, South Beach, Platinum Suede, 69"L 29"D 33"H	752.25	1,052.00		6.0	\$
305268	Sofa, Tangiers, 78"L 37"D 36"H	504.00	704.75		6.0	\$
305240	Tangiers Loveseat, 57.5"L 37"D 37"H	724.50	1,006.25		6.0	\$

Seating - Club Chairs

Item Code	Description	Discount (\$)	Regular (\$)	Qty	Tax %	Total
305225	Baja Chair, 36"L 30.5"D 28"H	668.75	928.75		6.0	\$
305235	Chair, Allegro, Blue Fabric, 36"L 34.5"D 29.5"H	630.75	882.00		6.0	\$
305072	Chair, Barcelona, Black, 30"L 31"D 35"H	915.25	1,280.00		6.0	\$
305073	Chair, Barcelona, White, 30"L 30"D 31"H	984.75	1,377.25		6.0	\$
305263	Chair, Naples, Black Vinyl, 36"L 30"D 28"H	392.75	549.50		6.0	\$
305269	Chair, Tangiers, 34"L 37"D 36"H	353.75	494.75		6.0	\$
305070	Chair, Tub, Key West, Black, 31"L 31"D 31"H	443.00	619.50		6.0	\$
305320	Key Largo Chair, Black Fabric, 35"L 35"D 34"H	569.75	796.75		6.0	\$

B-1 122217 080118 083600172



Specialty Furniture Order Form

All orders are governed by the GES Payment Policy and GES Terms & Conditions of Contract as specified in this Exhibitor Services Manual.

Discount Deadline Date:
August 20, 2018

Company Name _____ Email _____ Phone Number _____ Booth Number _____

Seating - Club Chairs

305102	Munich Corner Chair, 26"L 27"D 28.5"H	571.75	794.75		6.0	\$
305363	Naples Chair, Powered Black Vinyl, 36"L 30"D 28"H	874.75	1,223.25		6.0	\$
305222	Roma Chair, Powered White Vinyl, 37"L 31"D 33"H	874.75	1,223.25		6.0	\$

Seating - Chairs

Item Code	Description	Discount (\$)	Regular (\$)	Qty	Tax %	Total
305152	Chair, Altura, Guest, 25"L 20"D 34"H	124.00	159.00		6.0	\$
305041	Chair, Berlin, Black/White, 18"L 22"D 32"H	138.75	194.00		6.0	\$
305042	Chair, Berlin, Red/White, 18"L 22"D 32"H	138.75	194.00		6.0	\$
305110	Chair, Brewer, Black, 20"L 20"D 32"H	81.25	104.00		6.0	\$
305260	Chair, Christopher, White Vinyl w/Chrome, 17"L 19"D 35"H	121.25	169.75		6.0	\$
305285	Chair, Duet Stack, Black/Chrome, 23"L 21"D 33"H	80.75	113.00		6.0	\$
305232	Chair, Fusion, Red/White, 19"L 21"D 32"H	173.25	242.25		6.0	\$
305271	Chair, La Brea Swivel, Charcoal Gray Fabric, 35"L 27"D 40"D	398.75	557.75		6.0	\$
305270	Chair, Madden Arm, Lt. Gray Vinyl, 27"L 32"D 33"H	411.00	574.75		6.0	\$
305284	Chair, Rustique Arm, Gunmetal, 20"L 18"D 31"H	168.75	236.00		6.0	\$
305272	Chair, Swanson Swivel, White Vinyl, 28"L 25"D 18"H	253.25	354.25		6.0	\$
305250	Chair, Wendy, Clear Acrylic, 15"L 20"D 36"H	121.25	169.75		6.0	\$
305178	Fairfax Arm Chair, White Vinyl/ Brushed Metal, 27"L 26"D 30"H	575.75	799.75		6.0	\$
305047	Hopi Chair, Gray Linen, 21"L 25"D 34"H	230.25	320.00		6.0	\$
305442	Laguna Chair, 18"L 19"D 34"H	304.50	423.00		6.0	\$
305420	Malba Chair, Gray, 20"L 20"D 32"H	234.25	325.00		6.0	\$
305421	Malba Chair, Green, 20"L 20"D 32"H	234.25	325.00		6.0	\$
305103	Munich Armless Chair, 22.5"L 27"D 28.5"H	571.75	794.75		6.0	\$
305300	Razor Chair, White, 15.38"L 15.5"D 30.5"H	114.50	159.00		6.0	\$
305441	Zenith Chair, 19"L 22"D 32"H	296.25	411.75		6.0	\$

Seating - Ottomans

Item Code	Description	Discount (\$)	Regular (\$)	Qty	Tax %	Total
305316	Banquette, Quarter Curve Ottoman, 53"L 22"D 18"H	516.00	717.25		6.0	\$
305057	Beverly Bench Ottoman, Black Vinyl, 60"L 20"D 18"H	516.00	717.25		6.0	\$
305058	Beverly Bench Ottoman, Brown Fabric, 60"L 20"D 18"H	516.00	717.25		6.0	\$
305059	Beverly Bench Ottoman, Gray Fabric, 60"L 20"D 18"H	516.00	717.25		6.0	\$
305060	Beverly Bench Ottoman, Linene Fabric, 60"L 20"D 18"H	516.00	717.25		6.0	\$
305061	Beverly Bench Ottoman, Ocean Blue Fabric, 60"L 20"D 18"H	516.00	717.25		6.0	\$
305063	Beverly Bench Ottoman, Red Fabric, 60"L 20"D 18"H	516.00	717.25		6.0	\$
305064	Beverly Bench Ottoman, White Vinyl, 60"L 20"D 18"H	516.00	717.25		6.0	\$
305096	Endless Curved Ottoman, Black, 60.5"L 37.5"D 15"H	480.00	671.50		6.0	\$
305097	Endless Curved Ottoman, White, 60.5"L 37.5"D 15"H	480.00	671.50		6.0	\$
305280	Ottoman, Endless Square, Black, 34"L 34"D 15"H	102.75	143.75		6.0	\$
305279	Ottoman, Endless Square, White, 34"L 34"D 15"H	102.75	143.75		6.0	\$
305086	Ottoman, Half Bench, White Vinyl, 39"L 22"D 18"H	371.50	516.00		6.0	\$
305360	Ottoman, Marche Swivel, Blue Fabric, 17"L 17"D 18"H	223.00	309.50		6.0	\$

B-1 122217 080118 083600172



Specialty Furniture Order Form

All orders are governed by the GES Payment Policy and GES Terms & Conditions of Contract as specified in this Exhibitor Services Manual.

Discount Deadline Date:
August 20, 2018

Company Name	Email	Phone Number	Booth Number
--------------	-------	--------------	--------------

Seating - Ottomans

305352	Ottoman, Marche Swivel, Gray Fabric, 17"L 17"D 18"H	223.00	309.50		6.0	\$
305353	Ottoman, Marche Swivel, Linen Fabric, 17"L 17"D 18"H	223.00	309.50		6.0	\$
305358	Ottoman, Marche Swivel, Meadow Green, 17"L 17"D 18"H	223.00	309.50		6.0	\$
305359	Ottoman, Marche Swivel, Pear Yellow Fabric, 17"L 17"D 18"H	223.00	309.50		6.0	\$
305357	Ottoman, Marche Swivel, Plum Fabric, 17"L 17"D 18"H	223.00	309.50		6.0	\$
305354	Ottoman, Marche Swivel, Raspberry Fabric, 17"L 17"D 18"H	223.00	309.50		6.0	\$
305355	Ottoman, Marche Swivel, Red Fabric, 17"L 17"D 18"H	223.00	309.50		6.0	\$
305356	Ottoman, Marche Swivel, Rose Quartz Fabric, 17"L 17"D 18"H	223.00	309.50		6.0	\$
305351	Ottoman, Marche Swivel, White Vinyl, 17"L 17"D 18"H	223.00	309.50		6.0	\$
305092	Ottoman, South Beach, Wedge, Platinum, 25"L 31"D 18"H	288.00	402.75		6.0	\$
305251	Ottoman, Vibe Cube, Black Vinyl, 18"L 18"D 18"H	160.00	223.00		6.0	\$
305246	Ottoman, Vibe Cube, Blue, Vinyl, 18"L 18"D 18"H	142.75	199.75		6.0	\$
305242	Ottoman, Vibe Cube, Champagne, Vinyl, 18"L 18"D 18"H	142.75	199.75		6.0	\$
305243	Ottoman, Vibe Cube, Gold/Bronze, Vinyl, 18"L 18"D 18"H	142.75	199.75		6.0	\$
305241	Ottoman, Vibe Cube, Green, Vinyl, 18"L 18"D 18"H	142.75	199.75		6.0	\$
305248	Ottoman, Vibe Cube, Orange, Vinyl, 18"L 18"D 18"H	155.75	216.75		6.0	\$
305244	Ottoman, Vibe Cube, Pink, Vinyl, 18"L 18"D 18"H	142.75	199.75		6.0	\$
305239	Ottoman, Vibe Cube, Purple Vinyl, 18"L 18"D 18"H	155.75	216.75		6.0	\$
305245	Ottoman, Vibe Cube, Red, Vinyl, 18"L 18"D 18"H	142.75	199.75		6.0	\$
305238	Ottoman, Vibe Cube, Silver Vinyl, 18"L 18"D 18"H	155.75	216.75		6.0	\$
305237	Ottoman, Vibe Cube, Steel Blue Vinyl, 18"L 18"D 18"H	155.75	216.75		6.0	\$
305249	Ottoman, Vibe Cube, White Vinyl, 18"L 18"D 18"H	155.75	216.75		6.0	\$
305247	Ottoman, Vibe Cube, Yellow, Vinyl, 18"L 18"D 18"H	142.75	199.75		6.0	\$
305111	Sally Ottoman/Stool, White 12"L 12"D 17"H	155.75	216.75		6.0	\$

Seating - Office and Utility Seating

Item Code	Description	Discount (\$)	Regular (\$)	Qty	Tax %	Total
305126	Chair, Altura Task, 25"L 26"D 21"H	171.25	239.50		6.0	\$
305325	Chair, Executive, Black, 25"L 24"D 48"H	483.00	670.75		6.0	\$
305305	Chair, Executive, Pro, White, 27.5"L 27.5"D 45.7"H	275.50	385.25		6.0	\$
305068	Meeting Chair, Espresso Vinyl, 25.5"L 23.5"D 34"H	364.25	505.75		6.0	\$
305069	Meeting Chair, Taupe Fabric, 25.5"L 23.5"D 34"H	364.25	505.75		6.0	\$
305309	Meeting Chair, White Vinyl, 25.5"L 23.5"D 34"H	328.50	459.50		6.0	\$
305313	Pro Executive Guest Chair, Black Vinyl, 24"L 22"D 36"H	360.25	500.50		6.0	\$
305307	Pro Executive Mid Back Chair, Black Vinyl, 24"L 22"D 40"H	638.50	893.00		6.0	\$
305308	Pro Executive Mid Back Chair, White, 24"L 22"D 40"H	474.50	663.75		6.0	\$

Seating - Barstools

Item Code	Description	Discount (\$)	Regular (\$)	Qty	Tax %	Total
305370	Apex Barstool, Black Vinyl, 21"L 21"D 33"H	344.50	482.00		6.0	\$
305371	Apex Barstool, Blue Ultra Suede, 21"L 21"D 33"H	344.50	482.00		6.0	\$
305372	Apex Barstool, Red Vinyl, 21"L 21"D 33"H	344.50	482.00		6.0	\$
305373	Apex Barstool, White Vinyl, 21"L 21"D 33"H	344.50	482.00		6.0	\$

080118 083600172

B-1 122217



Specialty Furniture Order Form

All orders are governed by the GES Payment Policy and GES Terms & Conditions of Contract as specified in this Exhibitor Services Manual.

Discount Deadline Date:
August 20, 2018

Company Name _____ Email _____ Phone Number _____ Booth Number _____

Tables - Bar

Item Code	Description	Discount (\$)	Regular (\$)	Qty	Tax %	Total
305315	30" Round Madison Bar Table w/ Hydraulic Base, Gray Acajou	371.50	516.00		6.0	\$
305083	Bar Table w/ Hydraulic Base, 30"RND 45"H	371.50	516.00		6.0	\$
305082	Bar Table w/ Standard Black Base, 30"RND 42"H	323.00	449.00		6.0	\$
305425	Bar Table/Hydraulic Chrome Base, Steel Blue, 30"RND 45"H	481.00	668.75		6.0	\$
305405	Madison Bar Table/Black Base, 30"RND 42"H	561.50	780.25		6.0	\$
305162	Rustique Square Metal Bar Table, 23.75"L 23.75"D 41.25"H	371.50	516.00		6.0	\$
305139	Table, Bar, Brushed Red/Hydraulic Chrome Base, 30" Round 45"H	356.75	498.75		6.0	\$
305133	Table, Bar, Graphite/Black, 30" Round 42"H	273.50	382.50		6.0	\$
305136	Table, Bar, Graphite/Black, 36" Round 42"H	335.25	468.75		6.0	\$
305142	Table, Bar, Graphite/Hydraulic Chrome Base, 30" Round 45"H	356.75	498.75		6.0	\$
305145	Table, Bar, Graphite/Hydraulic Chrome Base, 36" Round 45"H	418.75	585.75		6.0	\$
305134	Table, Bar, Maple/Black, 30" Round 42"H	273.50	382.50		6.0	\$
305137	Table, Bar, Maple/Black, 36" Round 42"H	335.25	468.75		6.0	\$
305143	Table, Bar, Maple/Hydraulic Chrome Base, 30" Round 45"H	356.75	498.75		6.0	\$
305146	Table, Bar, Maple/Hydraulic Chrome Base, 36" Round 45"H	418.75	585.75		6.0	\$
305130	Table, Bar, Red/Black, 30" Round 42"H	273.50	382.50		6.0	\$
305286	Table, Bar, Silver Textured Grain/Black Base, 30" Round 42"H	197.25	275.75		6.0	\$
305302	Table, Bar, Silver Textured Grain/Hydraulic Chrome Base, 30" Round 45"H	241.25	337.25		6.0	\$
305287	Table, Bar, White Laminate/Black Base, 36" Round 42"H	183.50	256.75		6.0	\$
305303	Table, Bar, White Laminate/Hydraulic Chrome Base, 36" Round 45"H	232.25	325.00		6.0	\$
305030	Ventura Communal Bar Table w/ Grommet Holes, Maple Top, 72.25"L 26.25"D 42"H	1,042.25	1,444.75		6.0	\$
305032	Ventura Communal Bar Table w/ Grommet Holes, White Top, 72.25"L 26.25"D 42"H	1,042.25	1,444.75		6.0	\$
305031	Ventura Communal Bar Table, Black Top, 72.25"L 26.25"D 42"H	1,042.25	1,444.75		6.0	\$
305033	Ventura Communal Bar Table, Maple Top, 72.25"L 26.25"D 42"H	1,042.25	1,444.75		6.0	\$
305034	Ventura Communal Bar Table, White Top, 72.25"L 26.25"D 42"H	1,042.25	1,444.75		6.0	\$
305020	Ventura Communal Black Bar Table, Powered, 72.25"L 26.25"D 42"H	1,393.25	1,935.00		6.0	\$
305022	Ventura Communal White Bar Table, Powered, 72.25"L 26.25"D 42"H	1,393.25	1,935.00		6.0	\$

Tables - Cocktail

Item Code	Description	Discount (\$)	Regular (\$)	Qty	Tax %	Total
305430	Alondra Cocktail Table, Glass, 47"L 24"D 16"H	517.00	719.25		6.0	\$
305433	Alondra Cocktail Table, Wood, Chrome, 47"L 24"D 17"H	408.75	567.50		6.0	\$
305435	Geo Cocktail Table, Wood, 47"L 24"D 17"H	406.50	564.50		6.0	\$
305113	Regis Table/Bench, 47"L 15.5"D 16"H	427.25	593.50		6.0	\$
305188	Sydney Powered Cocktail Table, Black, 48"L 26"D 18"H	530.50	742.00		6.0	\$
305187	Sydney Powered Cocktail Table, White, 48"L 26"D 18"H	530.50	742.00		6.0	\$
305014	Table, Cocktail, Geo, Chrome, 50"L 22"D 16"H	285.50	399.25		6.0	\$
305210	Table, Cocktail, Oliver, 47"L 27"D 19"H	283.50	396.50		6.0	\$
305016	Table, Cocktail, Silverado, 36" Round 17"H	329.75	461.25		6.0	\$
305025	Table, Cocktail, Sydney Black, 48"L 26"D 18"H	379.50	530.75		6.0	\$
305024	Table, Cocktail, Sydney White, 48"L 26"D 18"H	379.50	530.75		6.0	\$

B-1 122217 080118 083600172



Specialty Furniture Order Form

All orders are governed by the GES Payment Policy and GES Terms & Conditions of Contract as specified in this Exhibitor Services Manual.

Discount Deadline Date:
August 20, 2018

Company Name _____ Email _____ Phone Number _____ Booth Number _____

Tables - End Tables

Item Code	Description	Discount (\$)	Regular (\$)	Qty	Tax %	Total
305431	Alondra End Table, Glass, 20"L 20"D 20"H	486.00	675.00		6.0	\$
305432	Alondra End Table, Wood, Chrome, 20"L 20"D 21"H	334.25	464.50		6.0	\$
305254	Edge Table, LED Lighted w/AC Plug, 20"L 20"D 20"H	327.25	454.00		6.0	\$
305436	Geo End Table, Wood, 20"L 20"D 21"H	344.75	478.75		6.0	\$
305258	Luna Pedestal, LED Lighted w/AC Plug, 16"L 16"D 20"H	297.25	412.75		6.0	\$
305112	Regis End Table, 16"L 15.5"D 16.5"H	421.75	589.75		6.0	\$
305273	Table, Aura, White Metal, 15" Round 22"H	132.00	184.75		6.0	\$
305274	Table, E, Wood, 21"L 15.5"D 27.5"H	126.25	176.50		6.0	\$
305044	Table, End, Geo, Chrome, 26"L 26"D 20"H	258.50	361.50		6.0	\$
305211	Table, End, Oliver, 22" Round 22"H	248.50	347.50		6.0	\$
305046	Table, End, Silverado, 24" Round 22"H	309.25	432.75		6.0	\$
305050	Table, End, Sydney, Black, 27"L 23"D 22"H	279.75	391.50		6.0	\$
305048	Table, End, Sydney, White, 27"L 23"D 22"H	279.75	391.50		6.0	\$
305275	Table, Timber, Wood, 16" Round 17"H	155.50	217.50		6.0	\$

Tables - Conference

Item Code	Description	Discount (\$)	Regular (\$)	Qty	Tax %	Total
305402	10' Madison Table, 120"L 48"D 29"H	1,073.25	1,496.50		6.0	\$
305231	10' Table, Conf., Granite 120"L 46"D 29"H	817.25	1,135.25		6.0	\$
305400	5' Madison Table, 60"L 48"D 29"H	725.50	1,008.25		6.0	\$
305230	6' Table, Conf., Granite, 72"L 36"D 29"H	609.00	846.25		6.0	\$
305401	8' Madison Table, 96"L 60"D 29"H	883.50	1,228.00		6.0	\$
305026	8' Table, Conf., Granite, 96"L 44"D 29"H	780.25	1,083.50		6.0	\$
305001	Atomic Table, 36"RND 30"H	401.50	557.25		6.0	\$
305002	Atomic Table, 42"RND 30"H	401.50	557.25		6.0	\$
305410	Madison Conference Table, 42"RND 29"H	659.50	916.50		6.0	\$
305190	Powered Conference Table Module, Black, 5'L 2.25"D 2"H	111.50	156.00		6.0	\$
305175	Table, Conf., Geo, Black, 42"L 42"D 29"H	315.00	440.50		6.0	\$
305176	Table, Conf., Geo, Black, 60"L 36"D 29"H	508.50	711.25		6.0	\$
305173	Table, Conf., Geo, Chrome, 42"L 42"D 29"H	333.75	466.75		6.0	\$
305174	Table, Conf., Geo, Chrome, 60"L 36"D 29"H	508.50	711.25		6.0	\$
305027	Table, Conf., Graphite, 42" Round 29"H	418.75	585.75		6.0	\$
305293	Table, Conf., Merlin, Gray Laminate/Black, 46"L 29"D 30"H	331.75	464.00		6.0	\$
305281	Table, Conf., White Laminate, 42" Round 29"H	268.00	374.75		6.0	\$

Tables - Martini Bar

Item Code	Description	Discount (\$)	Regular (\$)	Qty	Tax %	Total
305004	Table, Bar, Martini 3 pc., 100"L 100"D 47"H	3,649.25	5,103.75		6.0	\$
305003	Table, Bar, Martini, 50"L 50"D 47"H	1,372.50	1,919.75		6.0	\$

Product Display

Item Code	Description	Discount (\$)	Regular (\$)	Qty	Tax %	Total
305415	Madison Bookcase, 36"L 12"D 72"H	513.00	713.00		6.0	\$

083600172
080118
B-1 122217



Specialty Furniture Order Form

All orders are governed by the GES Payment Policy and GES Terms & Conditions of Contract as specified in this Exhibitor Services Manual.

Discount Deadline Date:
August 20, 2018

Company Name _____ Email _____ Phone Number _____ Booth Number _____

Product Display						
Item Code	Description	Discount (\$)	Regular (\$)	Qty	Tax %	Total
305297	Pedestal, Powered Locking, Black, 24"L 24"D 36"H	432.00	604.25		6.0	\$
305295	Pedestal, Powered Locking, Black, 24"L 24"D 42"H	516.25	722.00		6.0	\$
305298	Pedestal, Powered Locking, White, 24"L 24"D 36"H	432.00	604.25		6.0	\$
305296	Pedestal, Powered Locking, White, 24"L 24"D 42"H	516.25	722.00		6.0	\$
305045	Posh Shelving, 36"L 18"D 72"H	490.25	681.00		6.0	\$

Office and Utility Furniture						
Item Code	Description	Discount (\$)	Regular (\$)	Qty	Tax %	Total
305294	Desk, Writing/Work Table, White Laminate/White, 48"L 24"D 30"H	312.25	436.75		6.0	\$
305416	Madison Credenza, 60"L 20"D 29"H	898.75	1,248.75		6.0	\$
305417	Madison Executive Desk, 60"L 30"D 29"H	816.25	1,135.25		6.0	\$
305129	Tech 3 Drawer File Cabinet on Castors, Black, 16"L 20"D 28"H	687.25	954.50		6.0	\$
305128	Tech Desk, Powered w/ 3 Drawer File Cabinet, Black Metal, 60"L 30"D 30"H	650.25	903.00		6.0	\$
305127	Tech Desk, Powered, Black Metal, 60"L 30"D 30"H	200.25	278.75		6.0	\$

Lamps						
Item Code	Description	Discount (\$)	Regular (\$)	Qty	Tax %	Total
305204	Lamp, Floor, Mason, Silver, 18" Round 55"H	248.50	347.50		6.0	\$
305205	Lamp, Table, Mason, Silver, 16" Round 26"H	337.75	472.50		6.0	\$

Electrical Outlets Not Included



Need power for that lamp or powered pedestal in your booth? Order electrical outlets separately for your booth space through the electrical service provider.

Reminder

Total and Sign: Return to Fax: (866) 329-1437 • International Fax: (702) 263-1520

Please Sign _____
Authorized Signature

_____ Date
Authorized Name - Please Print

I agree in placing this order that I have accepted GES Payment Policy and GES Terms & Conditions of Contract, including authorization for GES to retain personal information to better serve my need for GES services at future events.

Total Payment Enclosed

Cancellation Policy: Items cancelled will be charged **100%** of original price after move-in begins.

080118 083600172
B-1 122217



Convenience Package Order Form

All orders are governed by the GES Payment Policy and GES Terms & Conditions of Contract as specified in this Exhibitor Services Manual.

Natural Products Expo East / All Things Organic™ BioFach America
 Baltimore Convention Center
 September 13 - 15, 2018

Discount Deadline Date:
 August 20, 2018

Company Name _____ Email _____ Phone Number _____ Booth Number _____



Easy Ordering Tips:

- All prices include delivery, rental, and removal.
- Return your orders three (3) weeks before show move-in to ensure availability. At show site some items may not be available and substitutions might be necessary.
- Enjoy a fast and easy ordering experience online with Expresso:
<http://e.ges.com/083600172/packages/esm>



Stool Package A



Chair Package A

Standard Furniture Package

Item Code	Description	Discount (\$)	Regular (\$)	Qty	Tax %	Total
404301	Chair Package A	457.30	616.50		6.0	\$
	↳ Includes: (2) Padded Chairs, (1) Starbase Table 40"X30", (1) Wastebasket.					
404323	Display Case Package A	1,079.00	1,413.50		6.0	\$
	↳ Includes: (2) Padded Stools, (1) Starbase Table 30"X40", (1) 6' Half View Display Case.					
404324	Display Case Package B	1,080.50	1,415.50		6.0	\$
	↳ Includes: (2) Padded Chairs, (1) Starbase Table 40"X30", (1) 6' Half View Display Case.					
404311	Stool Package A	455.80	614.50		6.0	\$
	↳ Includes: (2) Padded Stools, (1) Starbase Table 30"X40", (1) Wastebasket.					

Standard Skirted Furniture Package

Item Code	Description	Color Code	Discount (\$)	Regular (\$)	Qty	Tax %	Total
4046	Chair Package B		355.05	455.50		6.0	\$
	↳ Includes: (2) Padded Chairs, (1) 6' Skirted Table 24"X30", (1) Wastebasket.						
4146	Stool Package B		388.55	498.00		6.0	\$
	↳ Includes: (2) Padded Stools, (1) 6' Skirted Counter 24"X42", (1) Wastebasket.						

Skirt Color Options

(Gray will be provided if no color is indicated.)



083600172

080118

P-1 040418

Form Continues on Next Page



Convenience Package Order Form

All orders are governed by the GES Payment Policy and GES Terms & Conditions of Contract as specified in this Exhibitor Services Manual.

Company Name _____ Email _____ Phone Number _____

Specialty Furniture Package

Item Code	Description	Discount (\$)	Regular (\$)	Qty	Tax %	Total
404504	Bar Package	2,053.50	2,872.25		6.0	\$
	↳ Includes: (2) White Oslo Barstools, (1) Martini Bar.					
404506	Premium Stool Package	731.25	1,022.25		6.0	\$
	↳ Includes: (2) White Banana Barstools, (1) Bar Table 30"X42".					

Total and Sign: Return to Fax: (866) 329-1437 • International Fax: (702) 263-1520

Please Sign _____
 Authorized Signature

 Authorized Name - Please Print

 Date

I agree in placing this order that I have accepted GES Payment Policy and GES Terms & Conditions of Contract, including authorization for GES to retain personal information to better serve my need for GES services at future events.

Total Payment Enclosed \$

Cancellation Policy: Package items cancelled will be charged **50%** of original price after move-in begins and **100%** of original price after installation.

080118 083600172

P-1 122217



Standard Exhibit Systems

With the following GES® standard exhibits to choose from, selecting the size and configuration that meets your tradeshow needs is easy. Our modular exhibits are hassle-free because you pay no design fees, no shipping fees, and no repair or refurbishing fees. Plus, you may customize the trim and panels, and choose from a wide variety of accessories to create a unique exhibit that reinforces your brand and marketing efforts.

All packages include rental, delivery, installation, and dismantling. For other custom furnishings, hanging signs, or graphics, chat with your GES National Servicenter® representative at www.ges.com/chat.

10x20 Exhibits



600004 - Exhibit System GEM #4, 10'x20' Inline Includes:

- one 117" x 12" digitally printed sign
- one 57-7/8" x 12" digitally printed sign
- one 2m counter
- six arm lights
- five shelves
- one standard 10' x 20' carpet
- no padding

10x10 Exhibits



600002 - Exhibit System GEM #2, 10'x10'

Inline Includes:

- one custom ID sign
- two arm lights
- one standard 10' x 10' carpet
- no padding



600003 - Exhibit System GEM #3, 10'x10'

Inline Includes:

- one custom ID sign
- three arm lights
- five shelves
- one 1m counter
- one standard 10' x 10' carpet
- no padding

Please note that although arm lights may be included in your package, electrical power must be ordered separately through the electrical services provider in your exhibitor service manual. Colors may vary due to facility lighting, printing limitations and dye lot differences.

Standard Exhibit Systems

Accessories



600410 - Exhibit, Ad Board, 1M x 8'



600110 - Exhibit, Armlight Black



600103 - Exhibit, Counter, 1M Curved



600101 - Exhibit, Counter, 1M x 1/2M x 40"H



600102 - Exhibit, Counter, 2M x 1/2M x 40"H



600221 - Exhibit, Light Box, Large 37"x85"



600222 - Exhibit, Light Box, Medium 37"x56"



600223 - Exhibit, Light Box, Small 37"x28"



661931 - Exhibit, Panel, Slatwall, 1M x 8'

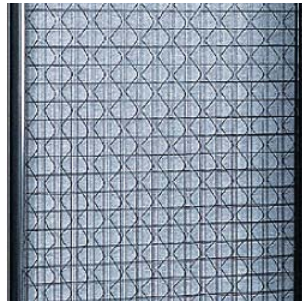

600291 - Exhibit, Panel, Wirewall, 1M



600243 - Exhibit, Shelf, 1M x 10" Deep

Trim and Panel Choices

Panel Type & Color



Coated: Black (C41)



Coated: Oxford White (C50)



Coated: Silver Gray (C79)



Fabric: Black (F41)



Fabric: Gray (F40)

Trim Color



Black (41)



Silver (79)

Please note that although arm lights may be included in your package, electrical power must be ordered separately through the electrical services provider in your exhibitor service manual. Colors may vary due to facility lighting, printing limitations and dye lot differences.

Standard Exhibits Graphics

Exhibit #2, 10 x 10 (600002)

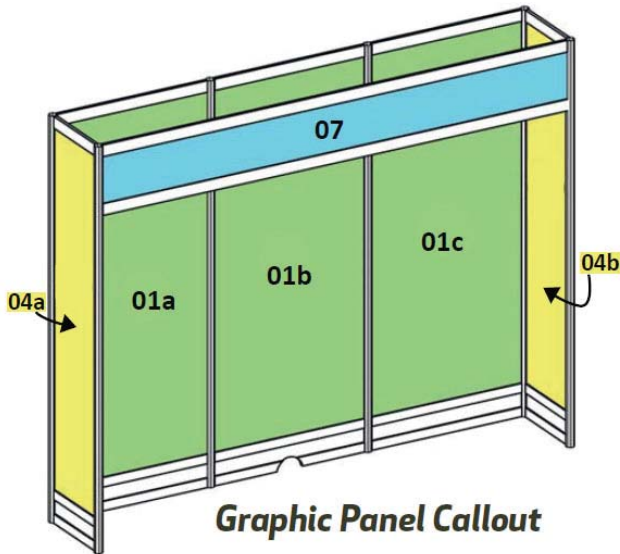

- 01 608301 38 1/8" wide x 86 1/4" tall
 Discount Price - \$474.75 /Regular Price - \$664.25
 Produced on 3/16" Thick White Foamcore
- 04 608304 18 7/16" wide x 86 1/4" tall
 Discount Price - \$238.25 /Regular Price - \$333.00
 Produced on 3/16" Thick White Foamcore
- 07 608307 117" wide x 12" tall
 Discount Price - \$203.00 /Regular Price - \$283.75
 Produced on 3/16" Thick White Foamcore

Order Standard Exhibit Graphics online by August 20, 2018 for best pricing. All orders placed after this date will receive the regular price.

All prices listed above are per panel.

Please note pricing listed is for graphic panels only. GEM units are rented separately.

GES requires a form of payment for booth graphics in order to produce signage. Please see Payment and Credit Card Authorization (G-2) for required information.

Please contact GES National Service Center at (800) 475-2098 or (702) 515-5970 with any questions or concerns.

Link: <https://e.ges.com/083600172/exhibit2/esm>



Booth Rendering

Please note that although arm lights may be included in your package, electrical power must be ordered separately through the electrical services provider in your exhibitor service manual. Colors may vary due to facility lighting, printing limitations and dye lot differences.

Standard Exhibits Graphics

Exhibit #3, 10 x 10 (600003)

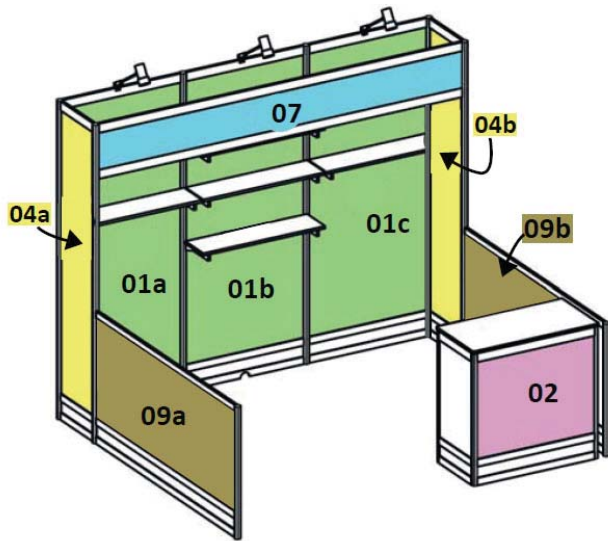

Graphic Panel Callout

- 01** 608301 38 1/8" wide x 86 1/4" tall
 Discount Price - \$474.75 /Regular Price - \$664.25
 Produced on 3/16" Thick White Foamcore
- 04** 608304 18 7/16" wide x 86 1/4" tall
 Discount Price - \$238.25 /Regular Price - \$333.00
 Produced on 3/16" Thick White Foamcore
- 07** 608307 117" wide x 12" tall
 Discount Price - \$203.00 /Regular Price - \$283.75
 Produced on 3/16" Thick White Foamcore
- 02** 608302 38 1/8" wide x 30 1/4" tall
 Discount Price - \$166.25 /Regular Price - \$232.50
 Produced on 3/16" Thick White Foamcore
- 09** 608309 77 1/2" wide x 30 1/4" tall
 Online Discount - \$337.75 /Regular Price - \$472.50
 Produced on 3/16" Thick White Foamcore

Order Standard Exhibit Graphics online by August 20, 2018 for best pricing. All orders placed after this date will receive the regular price.

All prices listed above are per panel.

Please note pricing listed is for graphic panels only. GEM units are rented separately.

GES requires a form of payment for booth graphics in order to produce signage. Please see Payment and Credit Card Authorization (G-2) for required information.

Please contact GES National Service Center at (800) 475-2098 or (702) 515-5970 with any questions or concerns.

Link: <https://e.ges.com/083600172/exhibit3/esm>



Booth Rendering

Please note that although arm lights may be included in your package, electrical power must be ordered separately through the electrical services provider in your exhibitor service manual. Colors may vary due to facility lighting, printing limitations and dye lot differences.

Standard Exhibits Graphics

Exhibit #4, 10 x 20 (600004)

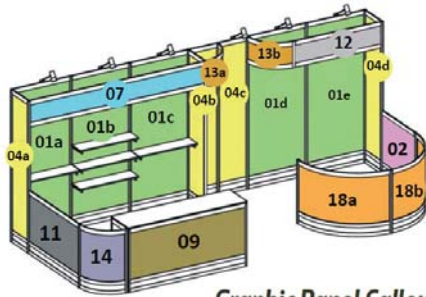

Graphic Panel Callout

- 12** 608312 57 7/8" wide x 12" tall
Discount Price - \$104.00 /Regular Price - \$145.50
Produced on 3/16" Thick White Foamcore
- 13** 608313 29 3/4" wide x 12" tall
Discount Price - \$52.00 /Regular Price - \$72.50
Produced on 1/8" Thick White Foamacell
- 18** 608318 60 3/4" wide x 30 1/4" tall
Discount Price - \$265.25 /Regular Price - \$371.00
Produced on 1/8" Thick White Foamacell
- 09** 608309 77 1/2" wide x 30 1/4" tall
Discount Price - \$337.75 /Regular Price - \$472.50
Produced on 3/16" Thick White Foamcore
- 14** 608314 29 3/4" wide x 30 1/4" tall
Discount Price - \$130.00 /Regular Price - \$181.75
Produced on 1/8" Thick White Foamacell

Order Standard Exhibit Graphics online by August 20, 2018 for best pricing. All orders placed after this date will receive the regular price.

All prices listed above are per panel.

Please note pricing listed is for graphic panels only. GEM units are rented separately.

GES requires a form of payment for booth graphics in order to produce signage. Please see Payment and Credit Card Authorization (G-2) for required information.

Please contact GES National Service Center at (800) 475-2098 or (702) 515-5970 with any questions or concerns.

Link: <https://e.ges.com/083600172/exhibit4/esm>

- 01** 608301 38 1/8" wide x 86 1/4" tall
Discount Price - \$474.75 /Regular Price - \$664.25
Produced on 3/16" Thick White Foamcore
- 04** 608304 18 7/16" wide x 86 1/4" tall
Discount Price - \$238.25 /Regular Price - \$333.00
Produced on 3/16" Thick White Foamcore
- 11** 608311 57 7/8" wide x 30 1/4" tall
Discount Price - \$100.25 /Regular Price - \$140.25
Produced on 3/16" Thick White Foamcore
- 02** 608302 38 1/8" wide x 30 1/4" tall
Discount Price - \$166.25 /Regular Price - \$232.50
Produced on 3/16" Thick White Foamcore
- 07** 608307 117" wide x 12" tall
Discount Price - \$203.00 /Regular Price - \$283.75
Produced on 3/16" Thick White Foamcore



Booth Rendering

Please note that although arm lights may be included in your package, electrical power must be ordered separately through the electrical services provider in your exhibitor service manual. Colors may vary due to facility lighting, printing limitations and dye lot differences.

Exhibit Systems Order Form

All orders are governed by the GES Payment Policy and GES Terms & Conditions of Contract as specified in this Exhibitor Services Manual.

Natural Products Expo East / All Things Organic™ BioFach America
 Baltimore Convention Center
 September 13 - 15, 2018

Discount Deadline Date:
 August 20, 2018

Company Name _____ Email _____ Phone Number _____ Booth Number _____



Easy Ordering Tips:

- All prices include delivery, rental, and removal.
- Return your orders three (3) weeks before show move-in to ensure availability. At show site some items may not be available and substitutions might be necessary.
- Arm lights and shelves cannot be placed on pipe and drape.

13 oz. Carpet Color Options

(Gray will be provided if no color is indicated below)



Exhibit Panel Color Options

(Gray Fabric Panel will be provided if no color is indicated below)



C Color Codes are Coated Panels
 F Color Codes are Fabric

Trim Color Options

(Silver will be provided if no color is indicated below)

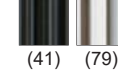

Standard Exhibits

10x10 Exhibits

Item Code	Description	Discount (\$)	Regular (\$)	Qty	Tax %	Total
600002	Exhibit System GEM #2, 10'x10' Inline	1,980.50	2,770.00		6.0	\$
	↳ Carpet Color Code: _____ Trim Color: _____ Panel Color: _____					
600003	Exhibit System GEM #3, 10'x10' Inline	3,730.00	5,216.75		6.0	\$
	↳ Carpet Color Code: _____ Trim Color: _____ Panel Color: _____					

10x20 Exhibits

Item Code	Description	Discount (\$)	Regular (\$)	Qty	Tax %	Total
600004	Exhibit System GEM #4, 10'x20' Inline	8,197.50	11,465.25		6.0	\$
	↳ Carpet Color Code: _____ Trim Color: _____ Panel Color: _____					

Accessories

Item Code	Description	Discount (\$)	Regular (\$)	Qty	Tax %	Total
600410	Exhibit, Ad Board, 1M x 8'	646.00	903.75		6.0	\$
600110	Exhibit, Armlight Black	96.00	134.25		6.0	\$
600103	Exhibit, Counter, 1M Curved	499.00	698.00		6.0	\$
	↳ Trim Color: _____ Panel Color: _____					
600101	Exhibit, Counter, 1M x 1/2M x 40"H	418.50	536.50		6.0	\$
	↳ Trim Color: _____ Panel Color: _____					
600102	Exhibit, Counter, 2M x 1/2M x 40"H	607.50	778.75		6.0	\$
	↳ Trim Color: _____ Panel Color: _____					
600221	Exhibit, Light Box, Large 37"x85"	820.00	1,146.75		6.0	\$
600222	Exhibit, Light Box, Medium 37"x56"	647.75	906.00		6.0	\$
600223	Exhibit, Light Box, Small 37"x28"	398.50	557.25		6.0	\$
661931	Exhibit, Panel, Slatwall, 1M x 8'	564.00	789.00		6.0	\$
600291	Exhibit, Panel, Wirewall, 1M	551.75	771.75		6.0	\$
600243	Exhibit, Shelf, 1M x 10" Deep	75.25	105.00		6.0	\$

Electrical or Utilities Under Carpet?

Yes No

080118 083600172 D-1 122217



Exhibit Systems Order Form

All orders are governed by the GES Payment Policy and GES Terms & Conditions of Contract as specified in this Exhibitor Services Manual.

Discount Deadline Date:
August 20, 2018

Company Name _____ Email _____ Phone Number _____ Booth Number _____

Total and Sign: Return to Fax: (866) 329-1437 • International Fax: (702) 263-1520

Please Sign 

X

Authorized Signature _____

Authorized Name - Please Print _____

Date _____

I agree in placing this order that I have accepted GES Payment Policy and GES Terms & Conditions of Contract, including authorization for GES to retain personal information to better serve my need for GES services at future events.

Total Payment Enclosed 

\$

Cancellation Policy: Items cancelled will be charged **50%** of original price after move-in begins and **100%** of original price after installation.

080118 083600172

D-1 122217



Booth ID Sign Order Form

All orders are governed by the GES Payment Policy and GES Terms & Conditions of Contract as specified in this Exhibitor Services Manual.

Natural Products Expo East / All Things Organic™ BioFach America
Baltimore Convention Center
September 13 - 15, 2018

Discount Deadline Date:
August 20, 2018

Company Name _____ Email _____ Phone Number _____ Booth Number _____



Easy Ordering Tips:

- Want an easier way? Submit your order online: <https://e.ges.com/083600172/boothIDsign/esm>

The standard 11" x 17" ID sign typically pinned to the top portion of your booth drape will not be automatically provided, unless you order it by the pre-show deadline of Monday, August 20, 2018. Please provide the following information to order a 11" x 17" booth ID sign: Booth number and company name.

ID sign pricing: There is No Charge for orders received after the deadline date. Orders received after Monday, August 20, 2018, are subject to availability.

Company Name as will appear on ID Sign:

Booth Number: _____

Item Code	Description	Price
600553	Booth ID Sign	No Charge

Review and Return: Return to Fax: (866) 329-1437 • International Fax: (702) 263-1520

Please Sign

X

Authorized Signature

Authorized Name - Please Print

Date

All orders are governed by the GES Payment Policy and GES Terms & Conditions of Contract as specified in this Exhibitor Services Manual.

Natural Products Expo East / All Things Organic™ BioFach America
Baltimore Convention Center
September 13 - 15, 2018

We are committed to partnering with you to provide comprehensive and effective graphic solutions for your event. The graphics print and production industry continuously evolves, and we want your graphics and images to look their absolute best. To ensure the highest quality output from your digital files, and to make file transfers as seamless as possible, please review and follow these guidelines when submitting artwork to GES. We also offer layout and design services for a fee. Please contact GES for details.



- Save money by providing your artwork/graphic files in the recommended formats.
- Send your graphics early with client name, show name, and booth number to avoid costly delays.
- Do not copy graphics from web pages as they will be low resolution and not suitable for your exhibit/sign.

Graphics

- Avoid setting type in Photoshop - instead use a vector-based program (such as Adobe Illustrator) for your type. If you do use vector smart objects, save the file as an .eps or .psd to retain vector properties.
- If you plan to add effects to your type (such as drop shadows or glows), follow these steps:
 - a. Import the Illustrator type into Photoshop
 - b. Add effects to the type
 - c. Separate the effects onto a layer
 - d. Delete the type layer
 - e. Assemble the type and photo in a vector program
- Always provide logos in a vector format.
- If you have critical PMS colors to match, provide us with a layered Photoshop file to allow for color editing.
- Use gradients carefully and sparingly. Gradients often “band,” and little can be done to correct the problem. Look at your high res file at 100% if you can see the banding, it WILL appear in the print. Adding 1 pt. of noise to the file may resolve the problem.

Suitable programs for images or logos:

- Adobe Illustrator CC 2018 - .ai, .pdf, .eps
- Adobe InDesign CC 2018 - .indd, .pdf
- Adobe Photoshop CC 2018 - .pdf, .tiff, .jpeg
- Adobe Acrobat

Color

If your Vector artwork needs to be color specific, please set up your files using the Pantone color pallet. Some Pantone colors are more likely to be achieved than others, we will match all Pantone colors to the best possible interpretation. We do our best to match any physical print sample, however, the colors may deviate slightly due to the limitations within the print process.



If providing colors as CMYK, please set colors as spot. Spot Colors are colors that have been specifically labeled within design software so that RIP Stations can recognize them. Setting colors to "Spot" it enables the RIP Station to adjust the colors independently of the design software to maximize work flow.



Vector Artwork

For the best quality, create graphics in vector format (AI, EPS). Logos taken from websites are generally GIF files, and those are not acceptable as they will not print clearly. Artwork produced for contour cut decals, such as solid company logos or text, must be supplied in a vector format (AI or vector EPS). Artwork created in a pixel format (TIF, JPG) is not compatible with equipment.

preferred* AI/EPS (vector)



GIF, TIFF, JPEG (raster)



Bitmap/Raster Artwork

TIF, JPEG, PDF and PSD - These are the preferred file formats for raster images. Files should be supplied at 100dpi at full size, or they should scale to those dimensions. If the resolution is lower than 100dpi, images can look blurry or pixelated when printed. If there is a lot of small text in the raster image, the file can be provided at higher resolutions to ensure print quality. Files obtained from the internet (JPG, GIF, PNG) or artwork created in MS Office applications (Word, Excel, PowerPoint, etc.) are often not suitable for high quality output for large/grand sized graphics or signage.

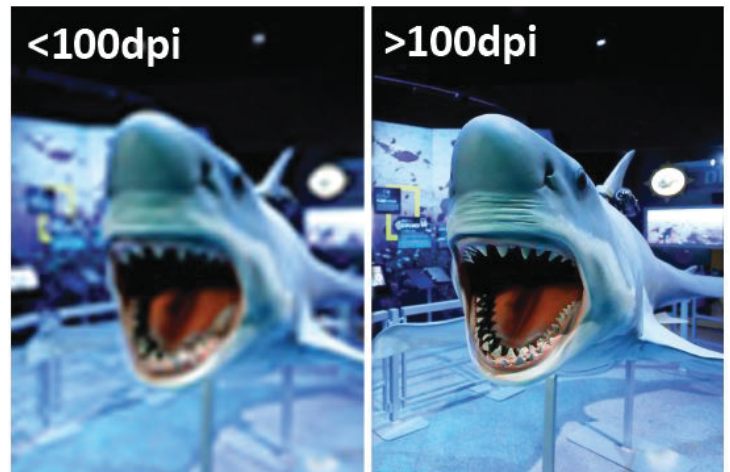

Order graphics and **upload artwork files** directly online: <https://e.ges.com/083600172/signs/esm>

Make sure your file(s) are labeled with the exhibiting company's name, the show name and the booth number (e.g. ABC Company_SHOW_Booth 1234.zip)

Digital File Preparation

All orders are governed by the GES Payment Policy and GES Terms & Conditions of Contract as specified in this Exhibitor Services Manual.

Natural Products Expo East / All Things Organic™ BioFach America
 Baltimore Convention Center
 September 13 - 15, 2018

Text

Turn all fonts to outlines or convert to paths before sending the files. If you are using a program where this is not an option, YOU MUST INCLUDE ALL FONTS with your files. OTF (open type fonts) are preferred.

Editable Text



Outlined Text - preferred*



Final Print package should contain:

- Consistent color pallets in all files (if providing colors as CMYK, please set colors as spot)
- All fonts converted to outlines and/or the fonts used
- Embedded images and/or linked images
- Final art at 100ppi at 100% scale (or an accurate aspect ratio with supporting resolution) Mandatory ZIP or SIT compression

Allow for Frames & Finishing

Some graphics are held in frames. Place all type and critical images at least 1" from all edges to avoid being covered by frames.

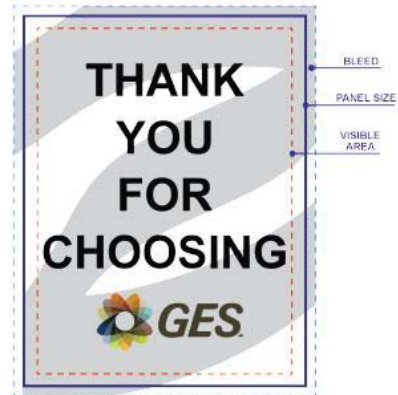

For graphics that are held in railroad bases, please place all type and critical images at least 6" from the base to avoid being covered.

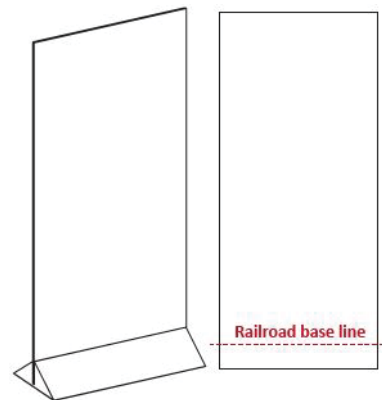

080118 083600172

080118

I-2 053118

Graphics and Signage Order Form

All orders are governed by the GES Payment Policy and GES Terms & Conditions of Contract as specified in this Exhibitor Services Manual.

Natural Products Expo East / All Things Organic™ BioFach America
 Baltimore Convention Center
 September 13 - 15, 2018

Discount Deadline Date:
 August 20, 2018

Company Name _____ Email _____ Phone Number _____ Booth Number _____

Order graphics and **upload artwork files** directly online: <https://e.ges.com/083600172/signs/esm>

Graphics and Signage

Item Code	Description	Discount (\$)	Regular (\$)	Qty	Tax %	Total
600534	22"W x 28"H Vertical Sign w/ Sign Holder, Double Sided	286.50	379.50		6.0	\$
600533	22"W x 28"H Vertical Sign w/ Sign Holder, Single Sided	216.50	303.00		6.0	\$
600535	72"W x 36"H Vinyl Banner (horizontal or vertical) w/ Silver Grommets, Single Sided	236.75	333.25		6.0	\$
600852	Freestanding 24"W x 84"H Vertical Ad Board w/ Cardboard Base, Double Sided	409.75	525.25		6.0	\$
600850	Freestanding 24"W x 84"H Vertical Ad Board w/ White Cardboard Base, Single Sided	260.75	334.25		6.0	\$
600853	Freestanding 38"W x 84"H Vertical Ad Board w/ White Cardboard Base, Double Sided	529.00	678.25		6.0	\$
600851	Freestanding 38"W x 84"H Vertical Ad Board w/ White Cardboard Base, Single Sided	380.00	487.25		6.0	\$
601099	Printed Cardboard Base for Freestanding Boards	23.30	29.75		6.0	\$

Total and Sign: Return to Fax: (866) 329-1437 • International Fax: (702) 263-1520

Please Sign _____
 Authorized Signature

 Authorized Name - Please Print

 Date

I agree in placing this order that I have accepted GES Payment Policy and GES Terms & Conditions of Contract, including authorization for GES to retain personal information to better serve my need for GES services at future events.

Total Payment Enclosed \$ _____

080118 083600172

I-1 102617



Standard Graphics

38" Ad Board

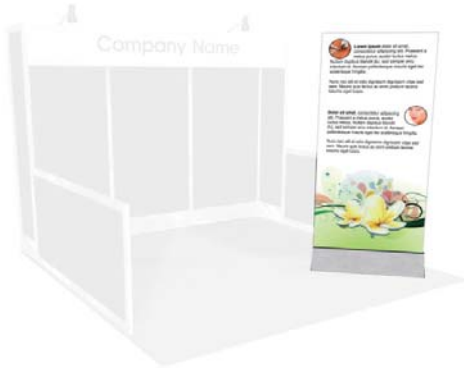

600851 Freestanding 38"W x 84"H Vertical Ad Board w/ White Cardboard Base, Single Sided (includes cardboard base, graphic & delivery)

600853 Freestanding 38"W x 84"H Vertical Ad Board w/ White Cardboard Base, Double Sided

*Includes cardboard base, graphic and delivery.
Printed base available at additional cost.*

24" Ad Board



600850 Freestanding 24"W x 84"H Vertical Ad Board w/ White Cardboard Base, Single Sided (includes cardboard base, graphic & delivery)

600852 Freestanding 24"W x 84"H Vertical Ad Board w/ Cardboard Base, Double Sided

*Includes cardboard base, graphic and delivery.
Printed base available at additional cost.*

22" x 28" with Sign Holder



600533 22"W x 28"H Vertical Sign w/ Sign Holder, Single Sided

600534 22"W x 28"H Vertical Sign w/ Sign Holder, Double Sided

Includes sign holder rental, graphic and delivery.

6' x 3' Banner



600535 72"W x 36"H Vinyl Banner (horizontal or vertical) w/ Silver Grommets, Single Sided

*Banner is available horizontal or vertical.
Includes silver grommets.*

Move-In Options for Privately Owned Vehicles:

Privately Owned Vehicle (POV)

What is a Privately Owned Vehicle? A POV, or privately owned vehicle, is considered to be any vehicle that is primarily designed to transport passengers, not cargo or freight. Please note that these vehicles cannot have any branding and/or company logos on them to be considered a POV.

Examples of POVs: Passenger vehicles under 1 ton: Small pickup trucks, passenger vans, taxis, limos, Uber, Lyft, Cars, etc.

What is not a POV: Company Vehicles of any kind, trailers, moving vans, U-Hauls, Cargo Vans, vehicle with a lift gate, materials on skids/pallets, crates, anything requiring freight moving equipment.

Privately Owned Vehicles



NOT Privately Owned Vehicles



NOT ACCEPTABLE



Cartload Service: (600 lbs. max.) GES can help you unload your passenger vehicle. Ordering Cartload Service is available under the Hand Carry/Cartload & Privately Owned Vehicles tab or by [CLICKING HERE](#).

Cartload Service to Move-In & Move-Out

To Use Cartload Service

- Must have 2 people
- Must have “loose” product (not palletized/crated)
- Total weight of items must be less than 600lbs. (Cartloads that exceed 600lbs will be charged at standard Material Handling rates.)

- Vehicle must be “acceptable” as shown above

If ALL items above apply, you may use Cartload Service! Proceed to the Marshalling Yard.

- GES can help unload a passenger vehicle. Pre-order Cartload Service by [CLICKING HERE](#) for the order form.
- Move-In may happen at/or after the targeted **Installation Start Time & Date**.
- All Cartload customers **MUST** go to the GES Cartload Marshaling Yard to check in **FIRST**.

Cartload Lot O – Privately Owned Vehicles (POV) ONLY

M&T Bank Stadium in Lot O

701 W Ostend St. (Southwest corner at the intersection of Ostend and Ridgley)

Baltimore, MD 21224-4629

United States of America

- Look for “**Cartload Lot O – Privately Owned Vehicles (POV) ONLY**” signs to check in for POV/Cartload.
- Check in with a GES Representative to obtain a dock pass and directions on where to be unloaded.
- Vehicles for Cartload Service will be unloaded first come, first served as dock space is available.
- GES will direct the vehicle toward the cartload area for unloading.
- Cars may not be left unattended at any time. There must be two (2) people with the vehicle; one person to go with the product to the booth space and one person to remove the vehicle from the dock.
- Cartload service has a **20-minute** max time to unload. Privately Owned Vehicles that are left unattended will be towed away at the exhibitor’s expense.
- POVs may park at local garages, after unloading at the dock and then return to the BCC for booth set-up. To find parking visit bestparking.com, select "Baltimore" and a map will pop up with garages and parking options.

Hand Carry: (100 lbs. max.) An exhibitor can **Hand Carry** your own materials to your booth, provided you **do not** use material handling equipment to assist you and you are moving 100lbs max of freight. Use of hand carts, two-wheeled dollies, or any four-wheel cart or dolly is **prohibited**. You will not be permitted access to the loading dock or freight areas.

- Cars may not be left unattended at any time. There must be two (2) people with the vehicle; one person to go with the product to the booth space and one person to remove the vehicle. Items unloaded curb side **cannot** be left unattended. There will be a maximum **15-minutes** to unload in the designated areas and any unattended vehicles will be towed away at the exhibitor’s expense.
- Privately Owned Vehicle must be performed by a full-time employee of the exhibiting company and could be asked by the Union for proof of employment (paystub/benefits documentation).
- The use of hand trucks, pallet jacks, lift gates or any other mechanical equipment is NOT permitted by anyone other than GES employees.
- Move-in may happen at/or after the targeted **Installation Start Time & Date**.
- More detailed Targeted Move-In and Move-Out instructions can be found by [CLICKING HERE](#).
- **Show Site Work Rules/Union Jurisdiction Regulations** must be abided by and can be found by [CLICKING HERE](#).

Please note that the Baltimore Convention Center is a Union Facility and Members of the Carpenters union claim jurisdiction on the operation of all material handling equipment, all unloading and reloading, and handling of empty containers. **An exhibitor may ONLY move materials that can be carried by hand, by one person in one trip, without the use of dollies, hand trucks, or other mechanical equipment.*

Designated Hand Carry locations are:

- Sharp St. Entrance
- Pratt and Howard St. Entrance
- Pratt and Charles St. Entrance

Hand Carry, Cartload Service (Curbside Cartload) Unloading Hours & Dates:

Monday, September 10	8:00am – 4:30pm
Tuesday, September 11	8:00am – 4:30pm
Wednesday, September 12	8:00am – 4:30pm

Make sure to check your Targeted Inbound Move-In and Installation Date & Time to make sure your booth will be ready.

Still have Questions?

If you still have questions about move-in be sure to use the contact information below to answer any questions you may have.

- **GES Service Center:** Contact GES if you have questions about order forms, need to place an order or need quotes for material handling or shipping. They can be reached at 1-800-842-6309.
- **Natural Products Expo East 2018 Exhibitor Services Specialist:** Contact your Exhibitor Services Specialist if you have questions regarding Target Move-In dates, Hand Carry and Cartload processes or any other general questions you may have. To Contact your Exhibitor Services Specialist [CLICK HERE](#).

INSERT THE CARTLOAD SERVICE ORDER FORM LINK HERE AT END OF DOCUMENT ALONG WITH THE GES INFORMATION.

Material Handling/Drayage Information

All orders are governed by the GES Payment Policy and GES Terms & Conditions of Contract as specified in this Exhibitor Services Manual.

Natural Products Expo East / All Things Organic™ BioFach America
Baltimore Convention Center
September 13 - 15, 2018

Benefits of Advance Shipping to the GES Warehouse

- Storage of materials for up to 30 days prior to your show.
- Delivery of shipments to your booth by your published set-up time.
- Some convention centers and hotels do not have facilities for receiving or storing freight.
- Saves valuable set-up time.

How to Ship in Advance to the GES Warehouse

- Remove all old shipping and empty storage labels.
- Fill out and attach enclosed Advance Shipping labels.
- Complete the enclosed Material Handling/Drayage Order Form.
- Remember to confirm receipt of your shipment prior to leaving for the show.
- All shipments must have a Bill of Lading or delivery slip showing the number of pieces, weight, and type of merchandise.
- Certified weight tickets must accompany all shipments.
- Take the time to ensure that your display and products are packed neatly and securely.
- Do not ship uncrated materials to warehouse.

How to Ship to Exhibit Site

- Consign all domestic shipments c/o GES.
- Remove all old shipping and empty storage labels.
- Fill out and attach enclosed Direct Shipping labels.
- Complete the enclosed Material Handling Information Sheet.
- All shipments must have a bill of lading or delivery slip showing the number of pieces, weight, and type of merchandise.
- Certified weight tickets must accompany all shipments.
- Take the time to ensure that your display and products are packed neatly and securely.
- If you are shipping your carpet and/or lighting truss, make sure it is loaded last so it can be unloaded first.

Freight Carriers

Select a carrier with experience in handling exhibition materials. Make sure to give your carrier explicit information as to where and when to check in. Delivery and pick up times are often out of the range of normal delivery hours; make sure your carrier is committed to meeting your target dates and times. While making shipping plans to the show, also plan for the return shipment.

Tracking Shipments

Confirm your delivery date and time with your carrier, and have all pertinent shipping information in the hands of your representative at show site. You may also want to review the return of your goods at the end of the show. GES Logistics domestic shipments can be tracked online by going to:

www.ges.com/us/services/exhibition-transportation-tools.

Get an instant quote today at https://e.ges.com/083600172/logistics_Quote

Chat with us <http://www.ges.com/chat>



Estimating Material Handling Charges

Handling charges are based on the weight of the freight. Shipments are billed by the hundred weight and rounded up to the nearest hundred. Minimum per shipment may apply, see enclosed Material Handling/Drayage Order Form for details. Please prepay all shipping charges - GES cannot accept or be responsible for collect shipments. Crated and uncrated shipments must be separated and clearly identified on separate bills of lading with separate weight tickets; otherwise, GES will invoice the entire load at the uncrated rate.

- Crated - Material that is skidded, or is in any type of shipping container that can be unloaded at the dock with no additional handling required.
- Uncrated - Material that is shipped loose or pad-wrapped, and/or unskidded machinery without proper lifting bars or hooks.
- Special Handling - Defined as shipments that are loaded by cubic space and/or packed in such a manner as to require special handling, such as ground loading, side door loading, constricted space loading and designated piece loading or stacked shipments. Also included are mixed shipments and shipments without proper delivery receipts.
- Overtime Surcharges - Shows that move-in or move-out on weekends or after 4:30 PM during the weekday, may be subject to additional overtime surcharges. See enclosed Material Handling/Drayage Order Form for details.

Late Surcharges - May be charged an additional overtime surcharge

- If advance freight is received before or after the published deadline date for shipments to arrive at the warehouse. See enclosed Material Handling/Drayage Order Form for details.
- Freight shipments sent to the show after it has opened.
- Freight shipments that are received at show site that do not meet their published date and time.
- Shipment Surcharges - A surcharge will be incurred per shipment for those that are received with incomplete information on shipping labels identifying company name and booth number and/or shipments that are left on the show floor at the end of the show with no labels and no bill of lading turned in.

Machinery Labor and Equipment

Labor and equipment for uncrating, unskidding, positioning, leveling, dismantling, re-crating, and reskidding machinery and/or equipment must be ordered separately. Place your order for this labor using the Forklift Labor Order Form. If your material requires specialized rigging equipment, please notify us promptly so that we can make arrangements. When possible, supply your own rigging equipment with shipments and pre-rig your material.

Storing Empty Containers

Properly labeled empty shipping cartons will be picked up, stored, and returned after the show. Labels are available at the GES Servicenter® or from your GES Service Executive and are for empty storage only. Depending on the size of the show, it can take from two to twelve hours to return empty crates. Do not store any items in crates marked "empty." GES has no liability for damage to crates or items sent to empty storage in crates.

Outgoing Shipments

An OMHF (Outbound Material Handling Form / Bill of Lading) must accompany all outgoing shipments. Shipping information, outbound forms and labels will be available at the GES Servicenter®. Exhibitors selecting non-official carriers will need to make their own arrangements for pickup. Make sure that someone from your company will be on-site to oversee the outbound shipment of your display and product.

080118 083600172

R-1 012417

Measure of Damage

- Liability - GES is liable for loss or damage to your goods only if the loss or damage is caused by GES negligence.
- Sole Relief - If found liable for any loss, GES' sole and exclusive maximum liability for loss or damage to Customer's goods is limited to \$.50 (USD) per pound with a maximum liability of \$100 (USD) per container, or \$1,500.00 (USD) per shipment, whichever is less.

Insurance

All of your goods should be insured by your own insurance policy. Although we do our best to handle your goods as our own, there are many variables in shipping and handling that can affect your exhibit and products. GES has published GES Terms and Conditions of Contract that are in this exhibitor service manual. Please read them carefully. It is recommended that your goods be insured.

Work Zone

Customer acknowledges that the show site and surrounding areas are active work zones. Customer, its agents, employees and representatives are present at their own risk.

080118 083600172





R-1 012417



Save 10% on Material Handling with GES Transportation Plus.

GES is your one stop shop for event and trade show transportation. As the Official Services Provider, we can offer you competitive pricing and a seamless shipping experience along with these Transportation Plus benefits:



-  10% off material handling
-  GES on-site support professionals
-  24/7 online shipment tracking: <http://www.ges.com/us/logistics/tools>
-  Consolidated show invoice
-  Fully integrated storage and shipping solutions



Order your round-trip shipping today to qualify for 10% off material handling fees.

Get an instant quote today at: https://e.ges.com/083600172/logistics_quote

Discount does not apply to shipments that are considered small packages, local, truckloads, or shipments over 5,000 lbs.

Material Handling/Drayage Order Form

All orders are governed by the GES Payment Policy and GES Terms & Conditions of Contract as specified in this Exhibitor Services Manual.

Natural Products Expo East / All Things Organic™ BioFach America
Baltimore Convention Center
September 13 - 15, 2018

Discount Deadline Date:
August 20, 2018

Company Name _____ Email _____ Phone Number _____ Booth Number _____



Easy Ordering Tips:

- Material Handling is the unloading and delivery of exhibit freight to the exhibitor's booth on the show floor. Material handling charges will be invoiced to you at show site for any freight unloaded and delivered. Use this form to plan, estimate costs and pre-order this service.
- Crated Material is skidded, or is in any type of shipping container that can be unloaded at the dock with no additional handling required.
- Special Handling is defined as shipments that are loaded by cubic space and/or packed in such a manner as to require special handling, such as ground loading, side door loading, constricted space loading and designated piece loading or stacked shipments. Also included are mixed shipments and shipments without proper delivery receipts.
- Uncrated Material is shipped loose or pad-wrapped, and/or unskidded machinery without proper lifting bars or hooks. The advance receiving warehouse cannot receive uncrated shipments.

Step 1. Review Freight Material Handling Rates and Information

Advance Shipment to Warehouse (200 lbs. minimum per shipment)

	Crated	Special Handling
Rate	\$123.75 cwt	\$161.37 cwt

Advance Shipments to Warehouse Dates:

Tue, Aug 7, 2018: Advance shipments may begin arriving at warehouse.

Wed, Sep 5, 2018: Last day for shipments to arrive at warehouse. **The GES Advance Warehouse will be closed Monday, September 3, 2018, in observance of the Labor Day holiday.**

For Exhibitor set up date and times, please refer to the "Exhibitor Set Up Date & Time" on the Target Move-In Floor Plan:
<https://e.ges.com/083600172/targetmovein/esm>

Direct Shipment to Show Site (200 lbs. minimum per shipment)

	Crated	Special Handling	Uncrated
Rate	\$123.75 cwt	\$161.37 cwt	\$203.45 cwt

Direct Shipments to Show site Dates:

Shipments should arrive on:
**Reference Targeted Floorplan for Dates & Times.

PLEASE NOTE:

Anything arriving off target may be turned away or charged an off target surcharge, please check the target freight floorplan.
Carriers Must Check-In at the Marshaling Yard.

Cold Storage Shipments: No cold storage shipments will be accepted at the direct to show site address. ALL Cold/Frozen shipments must be shipped to the Halethorpe, MD warehouse. Please see https://e.ges.com/083600172/cold_storage_shipping_process/esm for more instructions regarding shipping. Cold/Frozen shipments will be refused if shipped to the show site and will be rerouted at the Exhibitors Expense.

Small Package

Cartons and envelopes received without documentation will be delivered without guarantee of piece count or condition. Maximum weight is 50 lbs. for the first shipment, per delivery. This includes UPS and Federal Express shipments. All shipments received via air carrier that do not fall under the small package category may be subject to special handling charges. First shipment of small packages will be charged \$45.25. Each additional package will be charged \$12.05.

CWT

083600172

080118

R-2 053118 Cstm



Material Handling/Drayage Order Form

All orders are governed by the GES Payment Policy and GES Terms & Conditions of Contract as specified in this Exhibitor Services Manual.

Company Name _____ Email _____ Phone Number _____ Booth Number _____

Step 2. Estimate Order

Small Packages

 1 1st Small Package Shipment x \$45.25 = _____ Total

 # of additional packages (each) x \$12.05 = _____ Total

Material Handling/Drayage

Calculate Total CWT (Enter in increments of 100's only; round up to the next 100 mark if your weight is more than 8 lbs. over the previous 100 mark. 200 pound minimum per shipment.). We understand that your calculation is only an estimate. Invoicing will be done from the actual weight. Adjustments will be made accordingly.

 pounds of freight ÷ 100 = Total CWT x Rate = Total

On Date: _____

By Carrier: _____

Total Number of Pieces: _____

Shipment Will Be Sent To:

Exhibit Site Warehouse

Total and Sign: Return to Fax: (866) 329-1437 • International Fax: (702) 263-1520

Please Sign _____
 Authorized Signature

_____ Date
 Authorized Name - Please Print

I agree in placing this order that I have accepted GES Payment Policy and GES Terms & Conditions of Contract, including authorization for GES to retain personal information to better serve my need for GES services at future events.

Total Payment Enclosed \$

Surcharges

Late/Early to Warehouse Shipment Surcharges:

30% (\$50 minimum) surcharge will apply to all shipments received after the published timeline. Monthly storage fee of _____ per cwt will apply before published timeline.

Off Target - Late/Early to Show Site Surcharge:

A 25% surcharge will apply to all inbound shipments arriving OFF TARGET.

Special Handling/Mixed Shipments:

A 30.4% surcharge will apply to items requiring special handling or mixed shipments.

Uncrated Shipments:

A 64.4% surcharge will apply to loose or pad-wrapped, and/or unskidded machinery without proper lifting bars or hooks.

Measure of Damage:

If found liable for any loss, GES' sole and exclusive maximum liability for loss or damage to Customer's goods is limited to \$.50 (USD) per pound with a maximum liability of \$100 (USD) per container, or \$1,500.00 (USD) per shipment, whichever is less.

Certified Weight Tickets Are Required For All Shipments:

Drivers with inbound shipments must check in at the GES warehouse or exhibit site by 2:00 PM to be guaranteed same day unloading. Warehouse receiving hours are Monday - Friday, 8:00 AM - 4:30 PM; Closed 12:00 PM - 1:00 PM and Holidays.

CWT

083600172

080118 083600172 R-2 053118 Cstm



What is "Special" Handling?

Special Handling applies to shipments that are loaded in such a manner as to require additional labor and handling to unload or load out. An additional fee beyond the standard crated rate will apply.

Special Handling Includes:

Ground Loading

- Vehicles that are not dock height, preventing the use of loading docks.
- When docks are not readily available.
- When convention facility has no dock space

Side Door Loading

- Shipments tendered for delivery in such a manner as to prevent access from the rear of the trailer.

Constricted Space Loading

- Freight loaded "high and tight" or down one side as to make shipments not readily available.

Designated Piece Loading

- When a trailer must be loaded in a particular sequence to ensure fit.

Stacked, Cubed-out, or Loose Shipments

- Shipments loaded in such a manner requiring items to be removed to ground level for delivery to booth.
- Items that would need to be unstacked/stacked, unstrapped/strapped, or loadbars to be removed/installed during the unload or load out process.

Multiple Shipments

- Shipments that are loaded mixed on the truck, failing to maintain shipment integrity and/or have multiple delivery areas.

Mixed Shipments

- Pieces for separate shipments that are loaded mixed throughout the delivery vehicle, or shipments of crated and uncrated goods where the percentage of uncrated is minimal and does not warrant full uncrated rate for shipment.

Improper Delivery Receipts

- Shipments that arrive without individual Bill of Lading. Possible examples might include: UPS, FedEx, company trucks, privately-owned vehicles.

Uncrated Shipments

- Material that is shipped loose or pad-wrapped, and/or unskidded machinery without proper lifting bars or hooks.

Special Handling Examples:



Side Door Loading

Constricted Space Loading



Stacked Shipments

Uncrated Shipment



Multiple Shipments

Use these shipping labels as they will expedite handling. Copies of these labels are acceptable if additional labels are needed.



FROM:



TO:

Full Exhibiting Company Name at Show

Natural Products Expo East / All Things Organic™ BioFach America

Name of Exhibition 083600172

BOOTH NUMBER

C/O GES
UPS Freight
6571 Washington Blvd.
Elkridge, MD 21075 USA

Shipment Should Arrive on or Between:
Tuesday, Aug 7, 2018 - Wednesday, Sep 5, 2018

The GES Advance Warehouse will be closed Monday, September 3, 2018, in observance of the Labor Day holiday.

Certified Weight Tickets are required for all Shipments. Drivers must check in by 2:00 PM to be guaranteed same day unloading. Warehouse receiving hours are Monday - Friday, 8:00 AM - 4:30 PM; Closed 12:00 PM - 1:00 PM & Holidays.

Carrier _____ of _____ pieces GES logo



FROM:



TO:

Full Exhibiting Company Name at Show

Natural Products Expo East / All Things Organic™ BioFach America

Name of Exhibition 083600172

BOOTH NUMBER

C/O GES
UPS Freight
6571 Washington Blvd.
Elkridge, MD 21075 USA

Shipment Should Arrive on or Between:
Tuesday, Aug 7, 2018 - Wednesday, Sep 5, 2018

The GES Advance Warehouse will be closed Monday, September 3, 2018, in observance of the Labor Day holiday.

Certified Weight Tickets are required for all Shipments. Drivers must check in by 2:00 PM to be guaranteed same day unloading. Warehouse receiving hours are Monday - Friday, 8:00 AM - 4:30 PM; Closed 12:00 PM - 1:00 PM & Holidays.

Carrier _____ of _____ pieces GES logo

Please print this label on a color printer if possible

Please print this label on a color printer if possible

Use these shipping labels as they will expedite handling. Copies of these labels are acceptable if additional labels are needed.



FROM:



FROM:

Please print this label on a color printer if possible



TO:

Full Exhibiting Company Name at Show

Natural Products Expo East / All Things Organic™ BioFach America

Name of Exhibition 083600172

BOOTH NUMBER

C/O GES Baltimore Convention Center One West Pratt Street Baltimore, MD 21201 USA

Shipment Should Arrive on or Between:

Saturday, Sep 8, 2018 after 8:00 AM - Thursday, Sep 13, 2018 by 9:00 AM

**Reference Targeted Floorplan for Dates & Times.

Please Note: Anything arriving off target may be turned away or charged an off target surcharge, please check the target freight floorplan.

*Carriers Must Check-In at the Marshaling Yard.

*No cold storage shipments will be accepted at the direct to show site address. Please refer to the Instructions for Cold Storage Warehouse Shipping and Delivery for details. Shipments will be refused if shipped to show site.

Certified Weight Tickets are Required for all shipments. Drivers must check in by 2:00 PM to be guaranteed same day unloading.

Carrier _____ of _____ pieces



TO:

Full Exhibiting Company Name at Show

Natural Products Expo East / All Things Organic™ BioFach America

Name of Exhibition 083600172

BOOTH NUMBER

C/O GES Baltimore Convention Center One West Pratt Street Baltimore, MD 21201 USA

Shipment Should Arrive on or Between:

Saturday, Sep 8, 2018 after 8:00 AM - Thursday, Sep 13, 2018 by 9:00 AM

**Reference Targeted Floorplan for Dates & Times.

Please Note: Anything arriving off target may be turned away or charged an off target surcharge, please check the target freight floorplan.

*Carriers Must Check-In at the Marshaling Yard.

*No cold storage shipments will be accepted at the direct to show site address. Please refer to the Instructions for Cold Storage Warehouse Shipping and Delivery for details. Shipments will be refused if shipped to show site.

Certified Weight Tickets are Required for all shipments. Drivers must check in by 2:00 PM to be guaranteed same day unloading.

Carrier _____ of _____ pieces



Please print this label on a color printer if possible

Target Move-In and Freight Information

All orders are governed by the GES Payment Policy and GES Terms & Conditions of Contract as specified in this Exhibitor Services Manual.

Natural Products Expo East / All Things Organic™ BioFach America
Baltimore Convention Center
September 13 - 15, 2018



Form Tips:

- A targeted move-in is a designated day and time for arrival of a particular exhibitor or exhibit area depending on their location within the facility, according to a target map/floor plan.
- Your assigned target is the date and time that your truck must check into the marshalling yard. Once the marshalling yard sends your truck to the building to start unloading your company's truck, your exhibit/samples are taken directly to your booth space.
- As long as your truck arrives on or before your target time on your targeted date, there is no additional off-target charge.
- Find your targeted/scheduled time for move-in by reviewing the Targeted Floor Plan provided by the show organizer for target move-in times. This is for the move-in of your exhibit only. Your product can arrive at a later date.



Attention

Attention:

- All inbound exhibit material and equipment is specifically targeted by booth number.
- Please refer to target assignments contained in this section.
- Do not allow your carrier to block your on-target freight with off-target freight as the entire load may be rescheduled.
- Every attempt will be made to accommodate all inbound deliveries within their targeted day. However, there can be no guarantees with respect to absolute delivery dates and times.
- We recommend scheduling installation labor to begin the day after your inbound target assignment.
- It remains the exhibitors' responsibility to ensure that their freight is loaded to accommodate the inbound target assignments. Please plan carefully.
- Off-target freight and equipment may be refused and/or rescheduled. Off Target Surcharge: 25% (\$30 minimum) will apply to all inbound shipments arriving off-target. Please refer to Target Schedule.

Important Reminders



Reminder

- A target assignment is the point at which direct deliveries may begin checking in. It is not the point at which set-up should be scheduled.
- Freight shipped through our warehouse will be delivered prior to the beginning of your assigned target date and time.
- Route your shipments carefully. Utilize only carriers who provide Bills of Lading and can be contacted at any point in time.
- Insure your material from the time it leaves your facility until it is returned.
- Do not allow your carrier to block your on-target freight with off-target freight as the entire load may be rescheduled.

Correct:



Incorrect:



Questions?



Contact

- Chat with us <http://www.ges.com/chat>
- Contact us online: <https://e.ges.com/083600172/contactus/esm>

R-21/R-22 012118 080118 083600172

Target Maps

All orders are governed by the GES Payment Policy and GES Terms & Conditions of Contract as specified in this Exhibitor Services Manual.

Natural Products Expo East / All Things Organic™ BioFach America
Baltimore Convention Center
September 13 - 15, 2018

Click the link below for target maps:

Target Maps:

<http://e.ges.com/083600172/targetmaps>

Clean Floor Policy

All orders are governed by the GES Payment Policy and GES Terms & Conditions of Contract as specified in this Exhibitor Services Manual.

Natural Products Expo East / All Things Organic™ BioFach America
Baltimore Convention Center
September 13 - 15, 2018

Clean Floor Policy Information

Attention Natural Products Expo East / All Things Organic™ BioFach America Exhibitors!

Due to the volume of crates, limited space for set up and to facilitate the installation and cleaning of aisle carpet, a Clean Floor Policy will be enforced.

Tuesday, September 11, 2018

5:00 PM Crates for booths 400 square feet and larger must be empty and labeled for removal.

Wednesday, September 12, 2018

12:00 PM Crates for booths 300 square feet and smaller must be empty and labeled for removal.

2:00 PM Cartons, fiber cases and packing materials must be labeled for removal.

5:00 PM Visqueen on booth carpet should be rolled up by the exhibitor or exhibitor appointed contractor and placed in the aisle. Please do not wait until the morning of show open to remove visqueen or you may incur additional janitorial costs.

All aisles must be 100 percent clear of product and any other items that may impede with the installation of aisle carpet.

Please be advised that if your crates are removed on clean floor night and then requested to be brought back from empty storage to your booth before show opening, there will be a \$ 349.50 charge per hour for a forklift and driver to bring your crate back to your booth.

Thank you for your help in making Natural Products Expo East / All Things Organic™ BioFach America a successful event!

Request for Pre-Printed Outbound Material Handling Release/Labels

All orders are governed by the GES Payment Policy and GES Terms & Conditions of Contract as specified in this Exhibitor Services Manual.

Natural Products Expo East / All Things Organic™ BioFach America
Baltimore Convention Center
September 13 - 15, 2018

Form Deadline Date:
August 20, 2018



Form Tips:

- This form is used to gather your shipping information for the destination of your freight after the show closes. This document is not a Bill of Lading (BOL).
- Save time checking out by completing this form for pre-printed outbound Material Handling documents and outbound address labels.
- In order to provide this service, please submit this form by August 20, 2018.
- Want an easier way? Fill out this information online and submit:
<https://e.ges.com/083600172/prePrint/esm>

Step 1. Tell us the location of materials for pickup (show site address).

Company/Consignee	Attention			
One West Pratt Street	Baltimore	MD	21201	USA
Street Address	City	State	Zip/Postal Code	Country
Phone	Fax		Booth Number	

Step 2. Tell us the location where freight should be sent.

Shipping Destination 1:

Number of Labels Needed:

Company/Consignee	Attention			
Street Address	City	State	Zip/Postal Code	Country
Phone	Fax		Booth Number	

Shipping Destination 2:

Number of Labels Needed:

Company/Consignee	Attention			
Street Address	City	State	Zip/Postal Code	Country
Phone	Fax		Booth Number	

Show site Instructions: Once your shipment is packed and ready to be picked up, please return the outbound material handling release form to the GES Servicer®. Verify the piece count, weight, and that the signature is on the outbound material handling release form prior to shipping out. Shipments without paperwork turned in will be returned to GES Warehouse or forced onto another carrier at Exhibitor's expense.

GES does not accept responsibility for any exhibitor property left on the show floor unattended at any time for any reason.

Measure of Damage: If found liable for any loss, GES' sole and exclusive maximum liability for loss or damage to Customer's Goods is limited to \$.50 (USD) per pound with a maximum liability of \$100.00 (USD) per container, or \$1,500.00 (USD) per shipment, whichever is less.

Review and Return: Return to Fax: (866) 329-1437 • International Fax: (702) 263-1520

Chat with us <http://www.ges.com/chat>



Freight Service Questionnaire

All orders are governed by the GES Payment Policy and GES Terms & Conditions of Contract as specified in this Exhibitor Services Manual.

Natural Products Expo East / All Things Organic™ BioFach America
Baltimore Convention Center
September 13 - 15, 2018

Form Deadline Date:
August 20, 2018

Company Name _____ Email _____ Phone Number _____ Booth Number _____



Attention

Required Information For Exhibitors with Freight Shipments:

- This form should be returned by all exhibitors shipping freight.
- By returning this form we can better plan and prepare for incoming freight.
- Want an easier way? Fill out this information online and submit:
<http://e.ges.com/083600172/freightQuestionnaire/esm>

1. Estimate total number of pieces being shipped:

_____ Crated
_____ Uncrated
_____ Machinery
_____ Total

2. Indicate total number of trucks in each category that you will use:

_____ Van Line
_____ Common Carrier
_____ Flatbed
_____ Co. Truck
_____ Overseas Container

3 List carrier name(s):

4. If using a Customs Broker, please print name:

Phone Number:

5. Print the name of person in charge of your move-in:

Phone Number:

6. What is the minimum number of days to set your display?

7. What is the weight of the single heaviest piece that must be lifted?

_____ lbs.

8. What is the total weight of your exhibit or equipment being shipped?

_____ lbs.

9. Is there any special handling equipment required to unload your exhibit materials, i.e. extended forklift blades, special slings, lifting bars, etc.?

It is the responsibility of the exhibitor to provide proper special handling instructions, and to ensure goods are packaged appropriately for shipment and movement by heavy equipment. Failure to provide special handling instructions will result in the elimination of any liability for loss or damage by GES.

Direct Shipments Only

1. What date and time are you scheduling your shipment(s) to arrive on-site?

080118 083600172

R-7 032316

Review and Return: Return to Fax: (866) 329-1437 • International Fax: (702) 263-1520

Chat with us <http://www.ges.com/chat>

Marshaling Yard and POV (Privately Owned Vehicles)

All orders are governed by the GES Payment Policy and GES Terms & Conditions of Contract as specified in this Exhibitor Services Manual.

Natural Products Expo East / All Things Organic™ BioFach America
Baltimore Convention Center
September 13 - 15, 2018

Tips For New Exhibitors



Tips

What is a marshaling yard? The Marshaling Yard is an offsite location where trucks are checked in and held until dock space for unloading becomes available onsite.

Why is a marshaling yard used? Large shows use a marshaling yard to ease vehicle congestion and to ensure the unloading process runs smoothly.

Savings



Save

- There is no charge for this Marshaling Yard service.
- Avoid late charges by checking the Show Schedule for arrival dates and times.

Marshaling Yard Site Address for all trucks and vehicles other than POVs (privately owned vehicles):

c/o GES
Natural Products Expo East / All Things Organic™
BioFach America
(Your Company Name & Booth Number)
TA Plaza
5501 O'Donnell Street
Baltimore, MD 21224
USA

Marshaling Yard Shipments should arrive on or between:

September 8 - 13, 2018
Check in hours are 6:00 AM - 2:00 PM

Shipments should arrive on:
**Reference Targeted Floorplan for Dates & Times:
<https://e.ges.com/083600172/targetmovein/esm>

Address for all POVs (privately owned vehicles):

M&T Bank Stadium in Lot O
701 W Ostend St.
(Southwest corner at the intersection of Ostend and Ridgley)
Baltimore, MD 21224-4629
United States of America

POV Shipments should arrive on or between:

September 10 - 12, 2018
Reference Targeted Floor Plan for POV unloading times

If you have Hand Carry/Cartload or POV (Privately Owned Vehicles), please see <https://e.ges.com/083600172/povmarshalingyard/esm> for more instructions regarding loading and unloading.

Marshaling Yard Process

It is important that you advise your carrier of this Marshaling Yard information to better facilitate your direct shipment to showsite.

- All delivering carriers must check in at the Marshaling Yard prior to show site deliveries. All inbound shipments will be weighed at the Marshaling Yard to obtain the gross or heavy weight.
- All inbound shipments must be accompanied by a certified weight certificate and Bill of Lading.
- At the Marshaling Yard, drivers will be assigned a number and will be dispatched to the appropriate dock at Baltimore Convention Center as space is available. Waiting time at the Marshaling Yard should be anticipated by your carrier. Every effort is made to keep this waiting time at a minimum. However, the waiting time depends on many factors, including the number of vehicles arriving to unload/load, the type of loads being unloaded at the Baltimore Convention Center, the number of booths on a truck, etc.
- All drivers are expected to adhere to GES' policies and procedures with respect to the loading and unloading of trailers.
- All POVs needing to unload at the receiving dock must check in at the POV lot. If "self-unloading" please see Marshaling Yard and Hand Carry Instructions for details: <https://ordering.ges.com/083600172/povmarshalingyard/esm>
- POV (privately owned vehicles) needing Cartload Service must check into the Marshaling Yard Lot (M&T Bank Stadium in Lot O) prior to coming into the receiving dock or you will be turned away.

Contact us for Assistance with your Inbound Freight Arrangements

R-9 041918 Cstmhc 080118 083600172



Contact

- Chat with us <http://www.ges.com/chat>
- Contact us online: <https://e.ges.com/083600172/contactus/esm>

Cartload Service Order Form

All orders are governed by the GES Payment Policy and GES Terms & Conditions of Contract as specified in this Exhibitor Services Manual.

Natural Products Expo East / All Things Organic™ BioFach America
 Baltimore Convention Center
 September 13 - 15, 2018

Form Deadline Date:
 August 20, 2018

Company Name _____ Email _____ Phone Number _____ Booth Number _____

POV (privately owned vehicles) needing Cartload Service must check into the Marshalling Yard Lot (M&T Bank Stadium in Lot O) prior to coming into the receiving dock or you will be turned away.

Vehicles That Qualify for Cartload - Under One (1) Ton



Sedan



Van



SUV



Small Pickup

Important Reminders

-  Maximum Weight 600 lbs to qualify for this service.
- Freight that is too large or heavy will be charged Material Handling rates
- Two (2) round trips allowed per booth.

Cartload Freight Services for Unloading Small Passenger Vehicles

- To facilitate the move-in and move-out of Exhibitors with small exhibit material shipments, cartload service is available for one (1) laborer with one (1) pushcart, for two (2) trips.
- This service is for those who have small hand carry items all of which must fit on a 4' x 4' skid. If you arrive with a truck, trailer, or truck with trailer filled with exhibit material you will not qualify for this service and will be redirected.
- A cartload is ten (10) pieces or less per cart, weighing less 600 lbs. total between two cartloads. There are two cartloads allowed per exhibitor.

Your vehicle must unload on the receiving dock of the exhibit hall. GES personnel will direct vehicles. The cart is not authorized to enter or go to any parking structure. There must be two (2) people with the vehicle; one person to go with your product to the booth space and one person to remove your vehicle from the unloading area to the parking area.

Freight that is too large or heavy will be charged Material Handling/Drayage rates. No personal trucks (one 1-ton and over), no rental trucks, trailers or bobtails will be unloaded through cartload service.

You may also order this service at the GES Servicenter at show site.

Exhibitors may not use carts without authorization by a GES manager.

Cartload Services

Item Code	Description	Rate (\$)	# of Trips	Total
200506	Cartload Service, Straight Time	81.75	1	\$
200506	Cartload Service, Over Time	81.75	1	\$

Total and Sign: Return to Fax: (866) 329-1437 • International Fax: (702) 263-1520

Please Sign _____
 Authorized Signature

 Authorized Name - Please Print

 Date

I agree in placing this order that I have accepted GES Payment Policy and GES Terms & Conditions of Contract, including authorization for GES to retain personal information to better serve my need for GES services at future events.

Total Payment Enclosed

R-14 050516 Cstm 080118 083600172



Vehicle Placement Order Form

All orders are governed by the GES Payment Policy and GES Terms & Conditions of Contract as specified in this Exhibitor Services Manual.

Natural Products Expo East / All Things Organic™ BioFach America
 Baltimore Convention Center
 September 13 - 15, 2018

Form Deadline Date:
 August 20, 2018

Company Name _____ Email _____ Phone Number _____ Booth Number _____

Order Deadline is 8/20/18



Easy Ordering Tips:

- Displaying a vehicle at the show? Please be as detailed as possible with the information you provide.
- GES charges a round-trip fee, per vehicle, to place a vehicle on the trade show floor. This will apply to rolling stock, self-propelled, towed and/or pushed vehicles/machinery. GES will receive equipment at show site and deliver to the Exhibitor booth. We will also handle the outbound as an inclusive service
- For dual axle vehicles measure the distance from the front wheel to between the back wheels.



Important Rules and Regulations

- The City Fire Marshal requires that battery cables must be disconnected, place a protective covering under the vehicle, gas tank must either be taped shut or have a lockable gas cap and may contain no more than a quarter (1/4) tank of fuel or 5 gallons, whichever is less fuel. Exhibitor is responsible for checking local Fire Marshal rules and regulations for additional requirements.
- Your presence is Required! Vehicle Placement must be Exhibitor supervised. GES assumes no liability for loss, damage or bodily injury arising out of the placement of Exhibitor's vehicle. Exhibitor assumes the responsibility and an liability arising therefrom, for the work performed by union labor under Exhibitor's supervision.
- Watch your toes! Exhibitor(s) must stay clear during movement of vehicle.

Step 1. Provide Vehicle Information

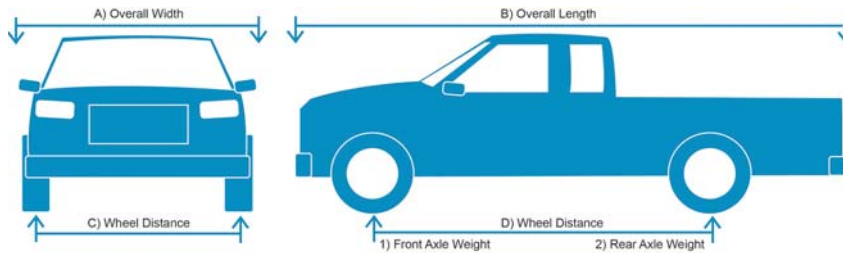

Vehicle Description*	A) Overall Width	B) Overall Length	Total Sq. Ft.	C) Wheel Distance	D) Wheel Distance	1) Front Axle Weight	2) Rear Axle Weight	Total Weight
1.								
2.								
3.								

Exhibitor will be at show site on _____, 20____, between _____ and _____ AM/PM to assist in the movement of the vehicle.

* Please attach separate sheet for more than 3 vehicles.

Step 2. Vehicle Placement Services (Round Trip)

Item Code	Description	Rate (\$)	# of vehicles	Total
200507	Vehicle Placement Round-Trip, per vehicle	256.00		\$

Total and Sign: Return to Fax: (866) 329-1437 • International Fax: (702) 263-1520

Please Sign

X

Authorized Signature

Authorized Name - Please Print

Date

I agree in placing this order that I have accepted GES Payment Policy and GES Terms & Conditions of Contract, including authorization for GES to retain personal information to better serve my need for GES services at future events.

Total Payment Enclosed

\$

R-15 071417 Cstm 080118 083600172



Show Site Storage Order Form

All orders are governed by the GES Payment Policy and GES Terms & Conditions of Contract as specified in this Exhibitor Services Manual.

Natural Products Expo East / All Things Organic™ BioFach America
 Baltimore Convention Center
 September 13 - 15, 2018

Discount Deadline Date:
 August 20, 2018

Company Name _____ Email _____ Phone Number _____ Booth Number _____



Easy Ordering Tips:

- An authorized company representative must be present at the time of delivery to your booth to inventory the items and to sign for receipt of items. Delivery hours may be restricted, check with the representatives in the GES Servicenter. An advance deposit is required to guarantee storage reservations.
- Straight Time: Monday through Friday from 8:00 AM to 4:30 PM.
- Overtime: All other times Monday through Friday. All day Saturday.
- Double Time: All day Sunday & holidays.

Step 1. Order Access Storage

Trailer Access Storage

- Access Storage – Locked storage will be available for materials not requiring refrigeration. Materials will not be accepted for storage unless the Exhibitor has an exact count of the units to be placed into storage. Access Storage is not secured storage. All items are stored at Exhibitor's sole risk.
- Storage Rate – Charges for space is per Exhibitor (per one-quarter of a trailer) one-quarter trailer minimum. This charge does not include labor.
- Shipments to Storage – Shipments should be consigned to your booth. After the materials are inventoried, please place your order for delivery of the materials into accessible storage at the GES Servicenter. GES representatives will give you special labels that you must place on the items you want placed into accessible storage. Only the items marked with these special labels will be placed in accessible storage. Do not use "Empty" labels.
- Notice of Delivery – Arrangements, in the form of a work order, must be made by 2:00 PM the day prior to delivery. The work order must be placed at the GES Servicenter. All remaining materials in accessible storage will be returned to the booth after show close (delivery charges will apply).
- Refer to Labor Information and Regulations form for additional requirements.

Item Code	Description	Rate (\$)	Qty	Total
200513	Access Storage, 1/4 Trailer	366.00		\$
200513	Access Storage, 1/2 Trailer	658.50		\$
200513	Access Storage, Full Trailer	1,170.50		\$

Skid Access Storage

- A storage area will be available for Exhibitor's literature and samples not requiring refrigeration.
- The charge for storage as described will be per skid, one skid minimum. This charge includes one-time delivery to storage area and delivery from storage to booth after the close of the show. Maximum size per single item is not to exceed 48" x 48" x 72."
- When ready for delivery of material to or from storage, please notify the GES Servicenter.
- Standard labor rates apply for each delivery to the booth or return of material to storage. Access storage is not secured storage. All items are stored at Exhibitor's sole risk.
- Refer to Labor Information and Regulations form for additional requirements.

Item Code	Description	Rate (\$)	X # Skids	Total
200513	Access Storage, Per Skid	65.50		\$

Additional Delivery Rates

Item Code	Description	Discount (\$)	Regular (\$)	Show Site (\$)	X # of Workers	X # Hours	Total
705044	Storage, ST	96.00	120.25	144.50			\$
705044	Storage, OT	147.75	184.75	221.50			\$
705044	Storage, DT	170.00	212.50	254.75			\$

Hate math? Let Espresso calculate your rates: <https://e.ges.com/083600172/labor/esm>

R-11/R-12 060518 080118 083600172

Chat with us <http://www.ges.com/chat>

Form Continues on Next Page



Show Site Storage Order Form

All orders are governed by the GES Payment Policy and GES Terms & Conditions of Contract as specified in this Exhibitor Services Manual.

Discount Deadline Date:
August 20, 2018

Company Name _____ Email _____ Phone Number _____ Booth Number _____

Step 2. Schedule Additional Deliveries

Invoice will be calculated according to actual hours worked. Additional labor required will be calculated and invoiced at the show site rate.

Schedule Dates	Schedule Start Time	Schedule End Time	Schedule Dates	Schedule Start Time	Schedule End Time	Schedule Dates	Schedule Start Time	Schedule End Time
MM/DD/YR	AM PM	AM PM	MM/DD/YR	AM PM	AM PM	MM/DD/YR	AM PM	AM PM
MM/DD/YR	AM PM	AM PM	MM/DD/YR	AM PM	AM PM	MM/DD/YR	AM PM	AM PM

Rates and Information for Storage Deliveries Requiring Equipment

- Order forklifts for heavy items or skids/pallets of materials from storage.
- Notice of Delivery – Arrangements, in the form of a work order, must be made by 2:00 PM the day prior to delivery. The work order must be placed at the GES Servicenter. All remaining materials in accessible storage will be returned to the booth after show close (delivery charges will apply).
- Refer to Labor Information and Regulations form for additional requirements.
- Straight Time: Monday through Friday from 8:00 AM to 4:30 PM.
- Overtime: All other times Monday through Friday. Saturday from 12:00 PM to 4:30 PM.
- Double Time: All other times Saturday. All day Sunday & Holidays.

Item Code	Description	Discount (\$)	Regular (\$)	Show Site (\$)	X # Crews	X # Hours	= Total
705200	5,000#, ST	279.75	349.50	419.50			\$
705200	5,000#, OT	327.25	408.75	490.75			\$
705200	5,000#, DT	392.50	491.00	588.75			\$

Hate math? Let Espresso calculate your rates: <https://e.ges.com/083600172/labor/esm>

Step 3. Schedule Forklift for Storage Deliveries

Invoice will be calculated according to actual hours worked. Additional labor required will be calculated and invoiced at the show site rate.

Schedule Dates	Schedule Start Time	Schedule End Time	Schedule Dates	Schedule Start Time	Schedule End Time	Schedule Dates	Schedule Start Time	Schedule End Time
MM/DD/YR	AM PM	AM PM	MM/DD/YR	AM PM	AM PM	MM/DD/YR	AM PM	AM PM
MM/DD/YR	AM PM	AM PM	MM/DD/YR	AM PM	AM PM	MM/DD/YR	AM PM	AM PM

Total and Sign: Return to Fax: (866) 329-1437 • International Fax: (702) 263-1520

Please Sign X _____
Authorized Signature

Authorized Name - Please Print

Date

I agree in placing this order that I have accepted GES Payment Policy and GES Terms & Conditions of Contract, including authorization for GES to retain personal information to better serve my need for GES services at future events.

Total Payment Enclosed \$ _____

R-11/R-12 060518 080118 083600172



Refrigerated & Frozen Storage Warehouse Move-In Process

ALL refrigerated and frozen products must be shipped to the offsite Cold Storage Warehouse to arrive between Monday, September 10, 2018 and Wednesday, September 12, 2018. Cold product will ONLY be accepted on these dates. Any cold/frozen freight shipped to the onsite address will be re-directed to the offsite warehouse at exhibitor's expense from the marshaling yard.

When organizing your cold/frozen shipment, make sure that you also complete the following forms:

- [Refrigerated/Frozen Storage Order Form](#) – order the storage area you will need by cubic feet.
- [Cold Storage Labor/Delivery Order Form](#) – order the labor for deliveries from storage to booth as well as from booth to storage. Include forklift/cart labor.
- [Cold Storage Delivery Schedule](#) – schedule the dates, times and product to be delivered to your booth.

Refrigerated/frozen shipping labels can be found at:

<https://ordering.ges.com/083600170/refrigfrozenlabels>.

Cold Storage Advance Shipment Address

GES
Natural Products Expo East / All Things Organic™ BioFach America
Exhibiting Company Name, Booth #
4801 Hollins Ferry Rd.
Suite B
Halethorpe, MD 21227
United States of America

Hours for cold storage receiving are:

- Monday - Tuesday, 8:00 AM to 4:00 PM through Wednesday, 8:00 AM - 12:00 PM Noon
- Closed 12:00 PM to 1:00 PM & Holidays
- NOTE: Deliver to loading dock located at rear of building

Exhibitors will be able to access their cold/frozen products starting at 6:00 PM on Wednesday evening, September 12, 2018. For questions or more information please contact Mary Barnes at 650-333-0589 or mbarnes@ges.com.

Refrigerated and Frozen Storage Order Form

All orders are governed by the GES Payment Policy and GES Terms & Conditions of Contract as specified in this Exhibitor Services Manual.

Natural Products Expo East / All Things Organic™ BioFach America
 Baltimore Convention Center
 September 13 - 15, 2018

Discount Deadline Date:
 August 20, 2018

Company Name _____ Email _____ Phone Number _____ Booth Number _____



Easy Ordering Tips:

- An authorized company representative must be present at the time of delivery to your booth to inventory the items and to sign for receipt of items. Delivery hours may be restricted, check with the representatives at the cold storage desk. An advance deposit is required to guarantee storage reservations.
- Containers must be marked either refrigerated or frozen. The facility booth numbers and company name must be also prominently displayed on each container. It is very important to use the Specially Coded Label that is provided in this manual. This ensures perishable items are delivered to the trailers for cold storage when they arrive.
- Exhibitors are not permitted direct access to the cold storage area. A work order must be placed with Centerplate or GES, if food prep is needed, at the GES Servicenter each time material is moved to or from storage. The work order must be signed when delivery is made.
- Shipments will be accepted beginning at 8:00 AM, Monday, September 10, 2018 at the Cold Storage Warehouse - DO NOT ship cold/frozen product direct to show site. Refer to instructions for Cold Storage Warehouse Shipping and Delivery: https://e.ges.com/083600172/cold_storage_shipping_process/esm
- Exhibitors will be able to access product onsite beginning at 12:30 PM on Wednesday, September 12.
- Target dates do not apply to Refrigerated & Frozen Storage.
- Straight Time: Monday through Friday from 8:00 AM to 4:30 PM. - 1 worker per 1 hour at Straight Time Rates
- Overtime: All other times Monday through Friday. All day Saturday. - 1 worker per 1 hour at Straight Time Rates
- Double Time: All day Sunday & Holidays. - 1 worker per 1 hour at Straight Time Rates

Step 1. Order Storage

- 1 Skid or 30 cubic feet per day. Storage charges begin on the day the shipment is received. Labor for delivery is not included. You will be billed for each delivery.
- Please confirm delivery arrangements the day before delivery of stored material is required at the storage control center at the loading docks.
- A work order must be placed at the storage control center each time material is moved to or from storage. The work order must be signed by a representative of the Exhibitor when delivery is made.
- During Show days, with the massive congestion in the aisles, it will take an additional amount of time for deliveries and it will be necessary to use a minimum of two laborers.

Storage is billed per Cubic foot

Cubic footage is determined as follows: Determine measurements of each piece in inches and multiply the width times the length times the height. Divide this figure by 1,728. Example: 10 cartons 24" x 16" x 13.5" = 5,184 (5,184 ÷ 1,728 = 3 cubic feet each x 10 cartons = 30 cubic feet). Storage required would be 1 Skid or 30 cubic feet.

Calculate Cubic Footage: $\frac{\text{Width} \times \text{Length} \times \text{Height}}{1728} = \text{Cubic Footage}$

Item Code	Description	Rate (\$)	X # of Cubic Ft.	Total
Refrigerated Storage				
200515	1 - 30 cu ft	13.60		\$
200515	31 - 120 cu ft	12.80		\$
200515	121 - 240 cu ft	12.25		\$
200515	241 cu ft and Greater	11.45		\$
Frozen Storage				
200514	1 - 30 cu ft	13.60		\$
200514	31 - 120 cu ft	12.80		\$
200514	121 - 240 cu ft	12.25		\$
200514	241 cu ft and Greater	11.45		\$

We understand that your calculation is only an estimate. Invoicing will be done from actual size. Adjustments will be made accordingly.

R-16 041918 Cstmhc 080118 083600172



Step 2. Storage Details

The items to be stored will be arriving on:

Date: _____ Time: _____ (am)(pm)

Please describe your product: _____

Total and Sign: Return to Fax: (866) 329-1437 • International Fax: (702) 263-1520

Please Sign

X

Authorized Signature

Authorized Name - Please Print Date

I agree in placing this order that I have accepted GES Payment Policy and GES Terms & Conditions of Contract, including authorization for GES to retain personal information to better serve my need for GES services at future events.

Total Payment Enclosed

\$

Notices

Due to temporary storage conditions, temperature regulations may vary 10-20°. GES will make every attempt to store your product according to specifications. GES assumes no liability for losses due to these conditions. Please note the following temperature regulations for storage:

Frozen Storageapproximately 25° below 0° F

Refrigerated Storageapproximately 35° - 40° F

You MUST have an authorized company representative present at the time of delivery to your booth to inventory the items and to sign for them. Storage is in trailers.

Check for correct consignment instructions and advise GES of booth delivery needs before the deadline date above.

Advance Storage Reservation

Your credit card must be on file with GES to make an advance storage reservation. See "Payment & Credit Card Charge Authorization" for credit card authorization.

Storage space is limited. Space will be guaranteed on a first come, first serve basis. Make your reservation early by completing this form, enclosing your deposit and mailing it to the address above before the deadline date. No refrigerated freight will be received at the advanced warehouse.

An advance deposit is required to guarantee all storage reservations.

R-16 041918 Cstmhc 080118 083600172



Cold Storage Labor/Delivery Information

All orders are governed by the GES Payment Policy and GES Terms & Conditions of Contract as specified in this Exhibitor Services Manual.

Natural Products Expo East / All Things Organic™ BioFach America
 Baltimore Convention Center
 September 13 - 15, 2018

Discount Deadline Date:
 August 20, 2018

Company Name Email Phone Number Booth Number



Easy Ordering Tips:

- Please complete this form for all cold storage labor needed. This includes deliveries from storage to booth as well as pick-ups from booth to storage. To determine if you need this labor, read this form carefully.
- Cold Storage labor will be required to move your product from the GES refrigerated and freezer trailers to your booth. Cold Storage labor will be required to move your product from your booth to the GES refrigerated and freezer trailers.
- If you require Cold Storage labor, a crew will be assigned consisting of (1) one forklift or cart with operator and (1) additional laborer.
- You will be billed for each delivery scheduled.
- Straight Time: Monday through Friday from 8:00 AM to 4:30 PM.
- Overtime: All other times Monday through Friday. All day Saturday.
- Double Time: All day Sunday & Holidays.

Important Information

Exhibitors are highly encouraged to schedule cold storage deliveries (to and from the booth) in advance of the show to ensure delivery time availability and avoid excessive costs. There are a finite number of deliveries made per hour "window" -- orders will be processed in the order received.

Cold storage deliveries (from storage to the booth) will be available beginning at 6:00 PM on Wednesday, September 12, 2018. Delivery time on show days begin 6:00 AM. Please confirm cold storage labor by 2:30 PM the day before the date requested. Please have an authorized company representative present at the time of delivery to your booth to inventory the items. Exhibitors wanting product delivered to their booth on Wednesday, September 12, must have their cold/frozen product arriving at the Cold Storage Warehouse no later than Tuesday, September 11.

Any product left in cold storage after 7:00 PM on Saturday, September 15 will be donated to the food bank. Please be sure to make arrangements for your carrier/shipper to arrive by 10:00 AM on Saturday, September 15, to pick up any product stored on the refrigerated/freezer trucks.

Note: Label your product so you know what product is for a specific day. Create a coding system to minimize access fees and help you get the product you need correctly, the first time. Deliveries will be suspended between 9:00 AM - 10:00 AM on show days.

The minimum charge for storage labor is one (1) hour per man per delivery and it is inclusive of delivery equipment. Gratuities in any form, including cash, gifts, or labor hours for work not actually performed are prohibited by GES. New orders placed onsite are subject to schedule availability.

Order Labor for Deliveries

Item Code	Description	Discount (\$)	Regular (\$)	Show Site (\$)	X # Workers	X # Hours	= Total
715044	Freezer Delivery, ST	96.00	120.25	144.50			\$
715044	Freezer Delivery, OT	147.75	184.75	221.50			\$
715044	Freezer Delivery, DT	170.00	212.50	254.75			\$
715045	Dry Storage Delivery, ST	96.00	120.25	144.50			\$
715045	Dry Storage Delivery, OT	147.75	184.75	221.50			\$
715045	Dry Storage Delivery, DT	170.00	212.50	254.75			\$
715046	Refrigerated Delivery, ST	96.00	120.25	144.50			\$
715046	Refrigerated Delivery, OT	147.75	184.75	221.50			\$
715046	Refrigerated Delivery, DT	170.00	212.50	254.75			\$

Hate math? Let Espresso calculate your rates: <https://e.ges.com/083600172/labor/esm>

Total and Sign: Return to Fax: (866) 329-1437 • International Fax: (702) 263-1520

Please Sign

X

Authorized Signature

Authorized Name - Please Print

Date

I agree in placing this order that I have accepted GES Payment Policy and GES Terms & Conditions of Contract, including authorization for GES to retain personal information to better serve my need for GES services at future events.

Total Payment Enclosed

\$

Please complete in detail, the schedule on the next page for all deliveries to booth as well as pick-ups from booth.



Cold Storage Delivery Schedule

All orders are governed by the GES Payment Policy and GES Terms & Conditions of Contract as specified in this Exhibitor Services Manual.

Natural Products Expo East / All Things Organic™ BioFach America
 Baltimore Convention Center
 September 13 - 15, 2018

Discount Deadline Date:
 August 20, 2018

Company Name _____ Email _____ Phone Number _____ Booth Number _____



Easy Ordering Tips:

- Please complete in detail, the schedule below for all deliveries to booth as well as pick-ups from booth.
- Please circle "Deliver to Booth" or "Pick up from Booth" and "Refrigerated" or "Frozen" accordingly.
- Reminder: Confirm storage deliveries the previous day prior to 2:30 PM at the GES Servicer labor desk.
- 8:00 AM is the latest request time in order to ensure timely delivery.
- New orders placed onsite are subject to schedule.
- You will be billed for each delivery scheduled.

Date(s)	Estimated Time of Delivery or Pick-Up	(Circle One)	(Circle One)	Please Describe Items to be Delivered to Booth or Picked up from Booth	# of Workers X	# of Hours X	Rate =	Total
	AM / PM	Delivered to Booth or Picked up from Booth	Refrigerated or Frozen					
	AM / PM	Delivered to Booth or Picked up from Booth	Refrigerated or Frozen					
	AM / PM	Delivered to Booth or Picked up from Booth	Refrigerated or Frozen					
	AM / PM	Delivered to Booth or Picked up from Booth	Refrigerated or Frozen					
	AM / PM	Delivered to Booth or Picked up from Booth	Refrigerated or Frozen					
	AM / PM	Delivered to Booth or Picked up from Booth	Refrigerated or Frozen					
	AM / PM	Delivered to Booth or Picked up from Booth	Refrigerated or Frozen					
	AM / PM	Delivered to Booth or Picked up from Booth	Refrigerated or Frozen					
	AM / PM	Delivered to Booth or Picked up from Booth	Refrigerated or Frozen					
	AM / PM	Delivered to Booth or Picked up from Booth	Refrigerated or Frozen					
	AM / PM	Delivered to Booth or Picked up from Booth	Refrigerated or Frozen					
	AM / PM	Delivered to Booth or Picked up from Booth	Refrigerated or Frozen					
	AM / PM	Delivered to Booth or Picked up from Booth	Refrigerated or Frozen					
	AM / PM	Delivered to Booth or Picked up from Booth	Refrigerated or Frozen					

Total and Sign: Return to Fax: (866) 329-1437 • International Fax: (702) 263-1520

Please Sign _____
 Authorized Signature

 Authorized Name - Please Print

 Date

I agree in placing this order that I have accepted GES Payment Policy and GES Terms & Conditions of Contract, including authorization for GES to retain personal information to better serve my need for GES services at future events.

Total Payment Enclosed \$ _____



R-16c 060716 Cstm 080118 083600172

USE THESE SHIPPING LABELS AS THEY WILL EXPEDITE HANDLING. Copies of these labels are acceptable if additional labels are needed.



Please select day(s) for delivery to your booth:

Wednesday Friday
Thursday Saturday

*A delivery order will need to be placed

Cold Storage receiving for Natural Products Expo East / All Things Organic™ BioFach America

0830600172

For better service, complete the following:

SHIP

TO:

Full Exhibiting Company Name at Show

BOOTH NUMBER On-site Exhibit Contact Phone #

C/O **GES**
4801 Hollins Ferry Rd.
Suite B
Halethorpe, MD 21227

For arrival starting:

Monday, Sept 10, 2018 Tuesday, Sept 11, 2018 8:00 AM - 4:00 PM
Wednesday, Sept 12, 2018 8:00 AM - 12:00 PM

Certified weight tickets are required for all shipments.

Carrier _____ of _____ Total boxes 



Please select day(s) for delivery to your booth:

Wednesday Friday
Thursday Saturday

*A delivery order will need to be placed

Cold Storage receiving for Natural Products Expo East / All Things Organic™ BioFach America

0830600172

For better service, complete the following:

SHIP

TO:

Full Exhibiting Company Name at Show

BOOTH NUMBER On-site Exhibit Contact Phone #

C/O **GES**
4801 Hollins Ferry Rd.
Suite B
Halethorpe, MD 21227

For arrival starting:

Monday, Sept 10, 2018 Tuesday, Sept 11, 2018 8:00 AM - 4:00 PM
Wednesday, Sept 12, 2018 8:00 AM - 12:00 PM

Certified weight tickets are required for all shipments.

Carrier _____ of _____ Total boxes 

Please print this label on a color printer if possible

Please print this label on a color printer if possible

USE THESE SHIPPING LABELS AS THEY WILL EXPEDITE HANDLING. Copies of these labels are acceptable if additional labels are needed.



Please select day(s) for delivery to your booth:

Wednesday Friday
Thursday Saturday

*A delivery order will need to be placed

Cold Storage receiving for Natural Products Expo East / All Things Organic™ BioFach America

0830600172

For better service, complete the following:

SHIP

TO: _____
Full Exhibiting Company Name at Show

BOOTH NUMBER _____ On-site Exhibit Contact Phone # _____

C/O **GES**
4801 Hollins Ferry Rd.
Suite B
Halethorpe, MD 21227

For arrival starting:

Monday, Sept 10, 2018 Tuesday, Sept 11, 2018 8:00 AM - 4:00 PM

Wednesday, Sept 12, 2018 8:00 AM - 12:00 PM

Certified weight tickets are required for all shipments

Carrier _____
Box number _____ of _____ Total boxes **GES** Global Experience Specialists



Please select day(s) for delivery to your booth:

Wednesday Friday
Thursday Saturday

*A delivery order will need to be placed

Cold Storage receiving for Natural Products Expo East / All Things Organic™ BioFach America

0830600172

For better service, complete the following:

SHIP

TO: _____
Full Exhibiting Company Name at Show

BOOTH NUMBER _____ On-site Exhibit Contact Phone # _____

C/O **GES**
4801 Hollins Ferry Rd.
Suite B
Halethorpe, MD 21227

For arrival starting:

Monday, Sept 10, 2018 Tuesday, Sept 11 - 2018 8:00 AM - 4:00 PM

Wednesday, Sept 12, 2018 8:00 AM - 12:00 PM

Certified weight tickets are required for all shipments

Carrier _____
Box number _____ of _____ Total boxes **GES** Global Experience Specialists

Please print this label on a color printer if possible

Please print this label on a color printer if possible

USE THESE SHIPPING LABELS AS THEY WILL EXPEDITE HANDLING. *Copies of these labels are acceptable if additional labels are needed.*



Perishable Food Products that will NOT be refrigerated upon delivery to the Convention Center

Direct to booth delivery for Natural Products Expo East / All Things Organic™ BioFach America

0830600172

For better service, complete the following:

SHIP TO:

Full Exhibiting Company Name at Show

BOOTH NUMBER On-site Exhibit Contact Phone #

C/O **GES**
Baltimore Convention Center
One West Pratt Street
Baltimore, MD 21201
USA

For arrival at show site:

Refer to target plan.

Certified weight tickets are required for all shipments.

Carrier _____
Box number _____ of _____ Total boxes 



Perishable Food Products that will NOT be refrigerated upon delivery to the Convention Center

Direct to booth delivery for Natural Products Expo East / All Things Organic™ BioFach America

0830600172

For better service, complete the following:

SHIP TO:

Full Exhibiting Company Name at Show

BOOTH NUMBER On-site Exhibit Contact Phone #

C/O **GES**
Baltimore Convention Center
One West Pratt Street
Baltimore, MD 21201
USA

For arrival at show site:

Refer to target plan.

Certified weight tickets are required for all shipments.

Carrier _____
Box number _____ of _____ Total boxes 

Please print this label on a color printer if possible

Please print this label on a color printer if possible

DO NOT

REFRIGERATE

Deliver to Booth

DO NOT

REFRIGERATE

Deliver to Booth

Cleaning and Porter Service Order Form

All orders are governed by the GES Payment Policy and GES Terms & Conditions of Contract as specified in this Exhibitor Services Manual.

Natural Products Expo East / All Things Organic(TM) BioFach America
 Baltimore Convention Center
 September 13 - 15, 2018

Discount Deadline Date:
 August 20, 2018

Company Name _____ Email _____ Phone Number _____ Booth Number _____

Exhibitors may order Recycle Porter Service and Compost Porter Service. GES will remove your recyclables and/or compost from your booth space at two-hour intervals, sort and place in appropriate waste conversion containers. Show hours only



Easy Ordering Tips:

- Vacuuming includes emptying your wastebasket nightly.
- If ordering Porter Service, GES will empty wastebaskets and wipe down counters at two hour intervals during show hours only. (Vacuuming is not included. Calculate by your booth size.)
- Cost of services will be invoiced based on the total area of your booth.

Step 1. Calculate Booth Square Footage

Width 10 X Length 10 = 100 Total Sq. Ft.

Step 2. Order Labor

Item Code	Description	Discount (\$)	Regular (\$)	Show Site (\$)	X # Workers	X # Hours	= Total
705010	Porter Service, ST	60.75	75.25	90.50			\$
705010	Porter Service, OT	105.75	132.25	159.00			\$

Use for booth wipedown, ice removal, etc. Hourly rates are listed above. The minimum charge for labor is four (4) hours per worker per day.

Hate math? Let Espresso calculate your rates: <https://e.ges.com/083600172/labor/esm>

Step 3. Order Cleaning Services

Vacuuming

Item Code	Description	Discount (\$)	Regular (\$)	Sq. Ft.	# of Days / Qty	Total
500601	Before Show Open Only (per sq. ft.)	0.40	0.57		1	\$
500600	Duration of Show (per sq. ft. per day)	0.39	0.50		3	\$
500602	Per Day (per sq. ft. per day)	0.66	0.92			\$

Shampooing

Item Code	Description	Discount (\$)	Regular (\$)	Sq. Ft.	Total
501004	Cleaning, Carpet Shampoo Before Show Open	0.70	0.91		\$

Mopping and Waxing

Item Code	Description	Discount (\$)	Regular (\$)	Sq. Ft.	# of Days / Qty	Total
501002	Cleaning, Damp Mop & Wax	1.23	1.71			\$

Porter Service - Emptying Wastebaskets

Item Code	Description	Discount (\$)	Regular (\$)	Sq. Ft.	# of Days / Qty	Total
501010	Porter Service, 0-500 sq.ft., Per Day	72.75	91.25			\$
501010	Porter Service, 501-1500 sq.ft., Per Day	97.75	122.75			\$
501010	Porter Service, 1501-3000 sq.ft., Per Day	114.50	144.50			\$
501010	Porter Service, 3,001 Sq.Ft. and Greater	251.75	378.75			\$

Recycle Porter Service

Item Code	Description	Discount (\$)	Regular (\$)	Sq. Ft.	# of Days / Qty	Total
501011	Recycle Service, 0-500 sq.ft., Per Day	72.25	91.25			\$
501011	Recycle Service, 501-1500 sq.ft., Per Day	97.75	122.75			\$
501011	Recycle Service, 1501-3000 sq.ft., Per Day	114.50	144.50			\$
501011	Recycle Service, 3001 sq.ft. & Up, Per Day	251.75	378.75			\$

J-1 053018 Cstm hr cd 080118 083600172



Cleaning and Porter Service Order Form

All orders are governed by the GES Payment Policy and GES Terms & Conditions of Contract as specified in this Exhibitor Services Manual.

Discount Deadline Date:
August 20, 2018

Company Name _____ Email _____ Phone Number _____ Booth Number _____

Compost Porter Service

Item Code	Description	Discount (\$)	Regular (\$)	Sq. Ft.	# of Days / Qty	Total
501012	Compost Service, 0-500 sq.ft., Per Day	72.25	91.25			\$
501012	Compost Service, 501-1500 sq.ft., Per Day	97.75	122.75			\$
501012	Compost Service, 1501-3000 sq.ft., Per Day	114.50	144.50			\$
501012	Compost Service, 3001 sq.ft. & Up, Per Day	251.75	378.75			\$

Recycle and Compost Porter Service

Item Code	Description	Discount (\$)	Regular (\$)	Sq. Ft.	# of Days / Qty	Total
501013	Recycle and Compost Service, 0-500 sq.ft., Per Day	72.25	91.25			\$
501013	Recycle and Compost Service, 501-1500 sq.ft., Per Day	97.75	122.75			\$
501013	Recycle and Compost Service, 1501-3000 sq.ft., Per Day	114.50	144.50			\$
501013	Recycle and Compost Service, 3001 sq.ft. & Up, Per Day	251.75	378.75			\$

Step 4. List dates and times Vacuuming Per Day/Periodic Porter service is needed:

Schedule Dates	Schedule Start Time	Schedule End Time	Schedule Dates	Schedule Start Time	Schedule End Time	Schedule Dates	Schedule Start Time	Schedule End Time
MM/DD/YR	AM PM	AM PM	MM/DD/YR	AM PM	AM PM	MM/DD/YR	AM PM	AM PM
MM/DD/YR	AM PM	AM PM	MM/DD/YR	AM PM	AM PM	MM/DD/YR	AM PM	AM PM

Total and Sign: Return to Fax: (866) 329-1437 • International Fax: (702) 263-1520

Please Sign _____
Authorized Signature

Authorized Name - Please Print

Date

I agree in placing this order that I have accepted GES Payment Policy and GES Terms & Conditions of Contract, including authorization for GES to retain personal information to better serve my need for GES services at future events.

Total Payment Enclosed \$ _____

Cancellation Policy: Due to material and labor costs, orders cancelled before move-in begins will be charged 50% of original price. Similarly, orders cancelled after move-in will be charged 100%.

J-1 053018 Cstm hrcd 080118 083600172



Installation and Dismantling Order Form

All orders are governed by the GES Payment Policy and GES Terms & Conditions of Contract as specified in this Exhibitor Services Manual.

Natural Products Expo East / All Things Organic™ BioFach America
Baltimore Convention Center
September 13 - 15, 2018

Discount Deadline Date:
August 20, 2018

Company Name	Email	Phone Number	Booth Number
Show Site Contact	Show Site Email	Show Site Phone Number	



Easy Ordering Tips:

- Please complete this form for all display labor needed. To determine if you need display labor, please read the show site work rules carefully.
- Exhibitor may unpack and place merchandise.
- Don't forget to order labor for Move In and Move Out.
- Straight Time (ST): Monday through Friday from 8:00 AM to 4:30 PM.
- Overtime (OT): Monday through Friday from 4:30 PM to 8:00 AM. All day Saturday and Sunday.
- Double Time (DT): Holidays.

Step 1. Order Labor

Item Code	Description	Discount (\$)	Regular (\$)	Show Site (\$)	# Workers	X # Hours	= Total
705000	Install & Dismantle, ST Move In	96.00	120.25	144.50			\$
705000	Install & Dismantle, ST Move Out	96.00	120.25	144.50			\$
705000	Install & Dismantle, OT Move In	147.75	184.75	221.50			\$
705000	Install & Dismantle, OT Move Out	147.75	184.75	221.50			\$

Hate math? Let Espresso calculate your rates: <https://e.ges.com/083600172/labor/esm>

Step 2. Please Indicate Service



What is GES Supervision? An exhibitor chooses GES Supervised when they do not want to be present when the work is completed. On most shows and services, there is a minimum surcharge for the professional supervision. Remember, when an exhibitor chooses this option, they do not need to schedule a date and time for services to be completed.

Option 1 (A 25% (\$ 50.00 minimum) surcharge will be added)

- GES Supervised (OK to proceed without exhibitor.)

Please complete Key Information form:

<https://e.ges.com/083600172/laborchecklist/esm>

GES will supervise labor to:

- Unpack and install display before Exhibitor arrival at show site.
- Dismantle and pack the display after show closing.

- Subject to terms and conditions of all GES policies, including terms and conditions of contract, including but not limited to sub-paragraph VII, b., Labor.
- A 25% (\$ 50.00 minimum) surcharge will be added to the labor rates above for this professional supervision.

Location of Booth/Dimension of Booth: Use the Booth Layout Form to represent your booth, indicate from each boundary how you would like your booth placed.

080118 083600172

L-1 071718

Form Continues on Next Page

Installation and Dismantling Order Form

All orders are governed by the GES Payment Policy and GES Terms & Conditions of Contract as specified in this Exhibitor Services Manual.

Company Name _____ Email _____ Phone Number _____ Booth Number _____



What is Exhibitor Supervision? An exhibitor chooses Exhibitor Supervised so they are able to instruct the laborer. The exhibitor is required to be in the booth and there are no supervision fees. Scheduling a date and time is necessary for this choice.

Option 2

- Exhibitor Supervised
 - Indicate workers needed for installation and dismantling.
 - GES assumes no liability for loss, damage or bodily injury arising out of the installation and/or dismantling of Exhibitor's property by GES provided union labor. Exhibitor assumes the responsibility and any liability arising therefrom, for the work performed by union labor under Exhibitor's supervision. Exhibitors must stay clear during movement of freight.

GES is responsible for the following type of booth:

- Pop-Up Two Story Custom
- Other: _____

Please estimate the number of workers and hours per worker needed for installation. Invoice will be calculated according to actual hours worked, relative to the original estimate and based upon the date received. Additional labor required will be calculated and invoiced at the show site rate.

Move In

Schedule Dates	Schedule Start Time	Schedule End Time	Number of Workers
MM/DD/YR	AM PM	AM PM	
MM/DD/YR	AM PM	AM PM	
MM/DD/YR	AM PM	AM PM	

Move Out

Schedule Dates	Schedule Start Time	Schedule End Time	Number of Workers
MM/DD/YR	AM PM	AM PM	
MM/DD/YR	AM PM	AM PM	
MM/DD/YR	AM PM	AM PM	

Important Information

Starting time can be guaranteed only when labor is requested for the start of the working day. All exhibit labor scheduled at the start of the working day will be dispatched to booth space. For all other starting times, check in at the labor desk one-half (½) hour before time requested. Labor cancelled without a 24 hour notice shall be charged a one (1) hour cancellation fee per worker. If Exhibitor fails to use the workers at the time confirmed, a one (1) hour "No-Show" charge per worker will apply.

The minimum charge for labor is one (1) hour per worker. Labor thereafter is charged in half (½) hour increments. Gratuities in any form, including cash, gifts, or labor hours for work not actually performed are prohibited by GES. GES requires the highest standards of integrity from all employees. Please call our confidential Always Honest hotline at (866) 225-8230 to report fraudulent or unethical behavior. All rates are subject to change if necessitated by increased labor and material costs.

Total and Sign: Return to Fax: (866) 329-1437 • International Fax: (702) 263-1520

Please Sign

X _____
Authorized Signature

Authorized Name - Please Print Date

I agree in placing this order that I have accepted GES Payment Policy and GES Terms & Conditions of Contract, including authorization for GES to retain personal information to better serve my need for GES services at future events.

Total Payment Enclosed

\$

L-1 071718 080118 083600172



Forklift Order Form

All orders are governed by the GES Payment Policy and GES Terms & Conditions of Contract as specified in this Exhibitor Services Manual.

Natural Products Expo East / All Things Organic™ BioFach America
 Baltimore Convention Center
 September 13 - 15, 2018

Discount Deadline Date:
 August 20, 2018

Company Name	Email	Phone Number	Booth Number
Show Site Contact	Show Site Email	Show Site Phone Number	



Easy Ordering Tips:

- In-booth forklift and labor may be required to assemble displays or when uncrating, positioning, and reskidding equipment and machinery.
- A forklift is required for moving equipment and materials weighing 200 pounds or more.
- If you require a forklift, a crew will be assigned consisting of a forklift with an operator.
- Don't forget to order labor for Move In and Move Out.
- Straight Time (ST): Monday through Friday from 8:00 AM to 4:30 PM.
- Overtime (OT): Monday through Friday from 4:30 PM to 8:00 AM. All day Saturday and Sunday.
- Double Time (DT): Holidays.

Step 1. Order Labor

Forklift with Operator, Per Hour

Item Code	Description	Discount (\$)	Regular (\$)	Show Site (\$)	# Crews	X # Hours	= Total
705200	5,000#, ST Move In	279.75	349.50	419.50			\$
705200	5,000#, ST Move Out	279.75	349.50	419.50			\$
705200	5,000#, OT Move In	327.25	408.75	490.75			\$
705200	5,000#, OT Move Out	327.25	408.75	490.75			\$
705200	5,000#, DT Move In	392.50	491.00	588.75			\$
705200	5,000#, DT Move Out	392.50	491.00	588.75			\$

Additional Worker, Freight, Per Hour

Item Code	Description	Discount (\$)	Regular (\$)	Show Site (\$)	# Crews	X # Hours	= Total
705030	Freight, ST Move In	96.00	120.25	144.50			\$
705030	Freight, ST Move Out	96.00	120.25	144.50			\$
705030	Freight, OT Move In	147.75	184.75	221.50			\$
705030	Freight, OT Move Out	147.75	184.75	221.50			\$
705030	Freight, DT Move In	170.00	212.50	254.75			\$
705030	Freight, DT Move Out	170.00	212.50	254.75			\$

Hate math? Let Espresso calculate your rates: <https://e.ges.com/083600172/labor/esm>

Step 2. Labor Information



What is Exhibitor Supervision? An exhibitor chooses Exhibitor Supervised so they are able to instruct the laborer. The exhibitor is required to be in the booth and there are no supervision fees. Scheduling a date and time is necessary for this choice.

Exhibitor Supervised (Do Not Proceed)

Exhibitor will supervise.

- Indicate workers needed for installation and dismantling.
- GES assumes no liability for loss, damage or bodily injury arising out of the installation and/or dismantling of Exhibitor's property by GES provided union labor. Exhibitor assumes the responsibility and any liability arising therefrom, for the work performed by union labor under Exhibitor's supervision. Exhibitors must stay clear during movement of freight.

GES is responsible for the following type(s) of work:

- Uncrating
- Leveling
- Reskidding
- Unskidding
- Dismantling
- Positioning
- Re-crating

Additional labor will be assigned if necessary.

080118 083600172 T-1 071718



All orders are governed by the GES Payment Policy and GES Terms & Conditions of Contract as specified in this Exhibitor Services Manual.

Company Name _____ Email _____ Phone Number _____ Booth Number _____

Step 3. Schedule In Booth Forklift Labor

Starting time can be guaranteed only when labor is requested for the start of the working day. All exhibit labor scheduled at the start of the working day will be dispatched to booth space. Confirm labor and forklifts by 2:30 PM the day before date requested. Please have a representative pick up the crew at the labor desk and supervise the work to be done. Upon completion, the Exhibitor's representative will return the crew to the labor desk and approve the work order. Equipment and labor cancelled without a 24 hour notice shall be charged a one (1) hour cancellation fee per worker and forklift. If Exhibitor fails to use the workers and equipment at the time confirmed, a one (1) hour cancellation fee per worker and forklift will apply.

The minimum charge for labor is one (1) hour per worker and equipment. Labor thereafter is charged in half (1/2) hour increments per worker and equipment. Gratuities in any form, including cash, gifts, or labor hours for work not actually performed are prohibited by GES. GES requires the highest standards of integrity from all employees. Please call our confidential Always Honest hotline at 866.225.8230 to report fraudulent or unethical behavior. All rates are subject to change if necessitated by increased labor and material costs.

Please estimate the number of workers and hours per worker needed for installation. Invoice will be calculated according to actual hours worked, relative to the original estimate and based upon the date received. Additional labor required will be calculated and invoiced at the show site rate.

Move In

Schedule Dates	Schedule Start Time	Schedule End Time	Number of Lifts/Workers
MM/DD/YR	AM PM	AM PM	
MM/DD/YR	AM PM	AM PM	

Schedule Dates	Schedule Start Time	Schedule End Time	Number of Lifts/Workers
MM/DD/YR	AM PM	AM PM	
MM/DD/YR	AM PM	AM PM	

Move Out

Schedule Dates	Schedule Start Time	Schedule End Time	Number of Lifts/Workers
MM/DD/YR	AM PM	AM PM	
MM/DD/YR	AM PM	AM PM	

Schedule Dates	Schedule Start Time	Schedule End Time	Number of Lifts/Workers
MM/DD/YR	AM PM	AM PM	
MM/DD/YR	AM PM	AM PM	

Total and Sign: Return to Fax: (866) 329-1437 • International Fax: (702) 263-1520

Please Sign _____
 Authorized Signature

 Authorized Name - Please Print

 Date

I agree in placing this order that I have accepted GES Payment Policy and GES Terms & Conditions of Contract, including authorization for GES to retain personal information to better serve my need for GES services at future events.

Total Payment Enclosed \$ _____

080118 083600172 T-1 071718



Hanging Sign / Truss Labor Information

All orders are governed by the GES Payment Policy and GES Terms & Conditions of Contract as specified in this Exhibitor Services Manual.

Natural Products Expo East / All Things Organic™ BioFach America
Baltimore Convention Center
September 13 - 15, 2018

See the Booth Regulations and Guidelines to determine if your booth type is allowed to have a hanging sign. If it is allowed, you must also receive approval from Show Management. Please complete the Booth Approval Form: https://e.ges.com/083600172/booth_approval/esm

Please complete and return the Hanging Sign / Truss Labor Order Form by August 20, 2018.

By sending us this information in advance you will help us assure your sign is properly assembled and installed.

Hanging Signs:

GES is responsible for assembly, installation, and removal of all hanging signs.

- All signs must be designed to comply with Show Organizer rules and regulations and facility limitations.
- Make sure all signs, with the exception of cloth banners and signs under 100 lbs., have structurally engineered rigging points as well as blueprints displaying a current structural engineer's stamp.
- If your sign requires electricity, make sure it is in working order and in accordance with the National Electric Code.
- Include Showsite Exhibitor contact information with the order.
- Include engineer-stamped drawings with hanging instructions as well as a set of assembly instructions (placement/orientation) with the order. GES accepts no liability for any work completed without such instructions, when required. Work is done at Exhibitor's risk and Exhibitor shall indemnify and defend GES and Show Organizer from any claims arising out of or related to the installation or dismantle of any sign without approved drawings.

Truss and Hoists:

GES is responsible for assembly, installation, and removal of all truss.

- All truss must be designed to comply with Show Organizer rules and regulations as well as facility limitations.
- All truss must be from a recognized manufacturer. Manufacturer load specifications for your truss must be at show site prior to rigging.
- Climbing on truss is strictly prohibited.
- All lamps and fixtures to be attached to truss must be in good working order and in compliance with the National Electric Code.
- All hoists must be from a recognized manufacturer and must be in good working order.
- Hoist maintenance records should be available for inspection by GES.

Hanging Sign Labor Order Form

All orders are governed by the GES Payment Policy and GES Terms & Conditions of Contract as specified in this Exhibitor Services Manual.

Natural Products Expo East / All Things Organic™ BioFach America
 Baltimore Convention Center
 September 13 - 15, 2018

Discount Deadline Date:
 August 20, 2018

Company Name	Email	Phone Number	Booth Number
Show Site Contact	Show Site Email	Show Site Phone Number	

All Hanging Signs must be approved by Show Management by July 31, 2018



Easy Ordering Tips:

- A crew will be assigned consisting of a lift with two riggers for aerial work.
- Don't forget to order labor for Move In and Move Out.
- Straight Time (ST): Monday through Friday from 8:00 AM to 4:30 PM.
- Overtime (OT): Monday through Friday from 4:30 PM to 8:00 AM. All day Saturday and Sunday.
- Double Time (DT): Holidays.

Step 1. Order Labor

Lift with Operator, Per Hour

Item Code	Description	Discount (\$)	Regular (\$)	Show Site (\$)	# Crews	# Hours	Total
705300	High Lift, ST Move In	614.75	768.50	922.00			\$
705300	High Lift, ST Move Out	614.75	768.50	922.00			\$
705300	High Lift, OT Move In	758.00	947.75	1,137.50			\$
705300	High Lift, OT Move Out	758.00	947.75	1,137.50			\$

Sign Assembly (Non-Electrical)

Item Code	Description	Discount (\$)	Regular (\$)	Show Site (\$)	# Workers	# Hours	Total
705020	Sign Assembly, ST Move In Only	96.00	120.25	144.50			\$
705020	Sign Assembly, OT Move In Only	147.75	184.75	221.50			\$

Hate math? Let Expresso calculate your rates: <https://e.ges.com/083600172/labor/esm>



What is Exhibitor Supervision? An exhibitor chooses Exhibitor Supervised so they are able to instruct the laborer. The exhibitor is required to be in the booth and there are no supervision fees. Scheduling a date and time is necessary for this choice.

What is GES Supervision? An exhibitor chooses GES Supervised when they do not want to be present when the work is completed. On most shows and services, there is a minimum surcharge for the professional supervision. Remember, when an exhibitor chooses this option, they do not need to schedule a date and time for services to be completed.

080118 083600172 H-2 073018



All orders are governed by the GES Payment Policy and GES Terms & Conditions of Contract as specified in this Exhibitor Services Manual.

Discount Deadline Date:
August 20, 2018

Company Name _____ Email _____ Phone Number _____ Booth Number _____

Show Site Contact _____ Show Site Email _____ Show Site Phone Number _____

Step 2. Please Indicate Service Hanging Sign Options

How many signs will be hung in your booth?

(if there are multiple signs, please complete an order form for each sign and label 1 of 3, etc)

Type of Sign

- Banner Structural Signage
 Systems Moss

Dimensions and Weight of Sign

Width _____ Height _____
Length _____ Total Weight _____ lbs

Height

Number of feet from floor to top of sign:
_____ Feet
Must be compliant with Show Rules and Regulations.

Electrical

(Not provided by GES. These services must be ordered through the electrical service provider)

Is your sign electrical?
 Yes No

Shape of Sign

- Square Rectangle
 Triangle Circle
 Serpentine Other _____

Pick Points

Number of structural pick points _____
Weight at each pick point _____
Have you submitted your structurally engineered rigging points? _____
Dates Submitted _____

Assembly

Does your sign require assembly?
 Yes No
If yes, GES must assemble your sign prior to hanging. See Hanging Sign / Truss Labor Rate and Information.

Hoists

(Not provided by GES. These services must be ordered through the facility)

Are hoists required?
 Yes No
if yes, how many? _____
 Exhibitor Owned GES Rental

Supervision

Do you want to supervise the hanging of your sign?
 Yes No
If yes, schedule the date you would like the sign to be hung in Step 3 of this form.
Please provide GES with a contact name and number to discuss _____

If no, GES will supervise without exhibitor present.
• A 25% (\$50.00 minimum) surcharge will be added to the labor rates above for this professional supervision.
• Date and time not required. No need to complete Step 3. Proceed to Total and Sign.

Your hanging sign received in the Advanced Warehouse could possibly be hung prior to your arrival only if GES has all of the required information.

Location of Sign

Use the Booth Layout Form provided in the kit to represent your booth and indicate placement of your sign. Sign orientation must be given by providing surrounding booth numbers.

080118 083600172

H-2 073018



All orders are governed by the GES Payment Policy and GES Terms & Conditions of Contract as specified in this Exhibitor Services Manual.

Discount Deadline Date:
August 20, 2018

Company Name _____ Email _____ Phone Number _____ Booth Number _____

Show Site Contact _____ Show Site Email _____ Show Site Phone Number _____

Step 3. Schedule Hanging Sign Labor for Exhibitor Supervised Work

Starting time can be guaranteed only when labor is requested for the start of the working day. All exhibit labor scheduled at the start of the working day will be dispatched to booth space. Confirm labor and equipment by 2:30 PM the day before date requested. If labor is not requested for the start of the working day, please have a representative pick up the crew at the labor desk and supervise the work to be done. Upon completion, the Exhibitor's representative will return the crew to the labor desk and approve the work order. Equipment and labor cancelled without a 24 hour notice shall be charged a one (1) hour cancellation fee per worker and equipment. If Exhibitor fails to use the workers and equipment at the time confirmed, a one (1) hour "Not Ready" charge per worker and equipment will apply.

The minimum charge for labor is one (1) hour per worker and equipment. Labor thereafter is charged in half (1/2) hour increments per worker and equipment. Gratuities in any form, including cash, gifts, or labor hours for work not actually performed are prohibited by GES. GES requires the highest standards of integrity from all employees. Please call our confidential Always Honest hotline at 866.225.8230 to report fraudulent or unethical behavior. All rates are subject to change if necessitated by increased labor and material costs.

Please estimate the number of workers and hours per worker needed for installation. Invoice will be calculated according to actual hours worked, relative to the original estimate and based upon the date received. Additional labor required will be calculated and invoiced at the show site rate.

Move In

Schedule Dates	Schedule Start Time	Schedule End Time	Number of Lifts/Workers
MM/DD/YR	AM PM	AM PM	
MM/DD/YR	AM PM	AM PM	

Schedule Dates	Schedule Start Time	Schedule End Time	Number of Lifts/Workers
MM/DD/YR	AM PM	AM PM	
MM/DD/YR	AM PM	AM PM	

Move Out

Schedule Dates	Schedule Start Time	Schedule End Time	Number of Lifts/Workers
MM/DD/YR	AM PM	AM PM	
MM/DD/YR	AM PM	AM PM	

Schedule Dates	Schedule Start Time	Schedule End Time	Number of Lifts/Workers
MM/DD/YR	AM PM	AM PM	
MM/DD/YR	AM PM	AM PM	

Total and Sign: Return to Fax: (866) 329-1437 • International Fax: (702) 263-1520

Please Sign

X

Authorized Signature

Authorized Name - Please Print

Date

I agree in placing this order that I have accepted GES Payment Policy and GES Terms & Conditions of Contract, including authorization for GES to retain personal information to better serve my need for GES services at future events.

Total Payment Enclosed

\$

080118 083600172

H-2 073018



Booth Layout - Hanging Signs

All orders are governed by the GES Payment Policy and GES Terms & Conditions of Contract as specified in this Exhibitor Services Manual.

Natural Products Expo East / All Things Organic™ BioFach America
Baltimore Convention Center
September 13 - 15, 2018

Form Deadline Date:
August 20, 2018

Company Name _____ Email _____ Phone Number _____ Booth Number _____

Show Site Contact _____ Show Site Email _____ Show Site Phone Number _____



Form Tips:

- Use bold lines to indicate the outline of your exhibit space.
- If this grid scale is too small for easy drawing return a separate sheet indicating booth layout.
- Return multiple booth layouts if necessary.

Step 1. Booth Information

Each square is _____ feet square since my booth is _____ feet wide by _____ feet long.

Back Adjacent Booth or Aisle Number: _____

Right Side Adjacent Booth or Aisle Number: _____

Left Side Adjacent Booth or Aisle Number: _____

Front Adjacent Booth or Aisle Number: _____

Step 2. Draw Your Booth Layout

Front of Booth

Review and Return: Return to Fax: (866) 329-1437 • International Fax: (702) 263-1520

080118 083600172

H-3 102615

Chat with us <http://www.ges.com/chat>



Use these shipping labels as they will expedite handling. Copies of these labels are acceptable if additional labels are needed.



FROM:



FROM:

ADVANCE SHIPMENT

TO:

Full Exhibiting Company Name at Show

Natural Products Expo East / All Things Organic™ BioFach America

Name of Exhibition

0830600172

Booth Number

C/O GES
UPS Freight
6571 Washington Blvd.
Elkridge, MD 21075 USA

Shipment Should Arrive on or Between:
Tuesday, Aug 7, 2018 - Wednesday, Sep 5, 2018

The GES Advance Warehouse will be closed Monday, September 3, 2018, in observance of the Labor Day holiday.

Certified Weight Tickets are required for all Shipments. Drivers must check in by 2:00 PM to be guaranteed same day unloading. Warehouse receiving hours are Monday - Friday, 8:00 AM - 4:30 PM; Closed 12:00 PM - 1:00 PM & Holidays.

Carrier _____ of _____ pieces GES

ADVANCE SHIPMENT

TO:

Full Exhibiting Company Name at Show

Natural Products Expo East / All Things Organic™ BioFach America

Name of Exhibition

0830600172

Booth Number

C/O GES
UPS Freight
6571 Washington Blvd.
Elkridge, MD 21075 USA

Shipment Should Arrive on or Between:
Tuesday, Aug 7, 2018 - Wednesday, Sep 5, 2018

The GES Advance Warehouse will be closed Monday, September 3, 2018, in observance of the Labor Day holiday.

Certified Weight Tickets are required for all Shipments. Drivers must check in by 2:00 PM to be guaranteed same day unloading. Warehouse receiving hours are Monday - Friday, 8:00 AM - 4:30 PM; Closed 12:00 PM - 1:00 PM & Holidays.

Carrier _____ of _____ pieces GES

Please print this label on a color printer if possible

Please print this label on a color printer if possible

Truss, Chain Hoist and Floodlight Order Form

All orders are governed by the GES Payment Policy and GES Terms & Conditions of Contract as specified in this Exhibitor Services Manual.

Natural Products Expo East / All Things Organic™ BioFach America
 Baltimore Convention Center
 September 13 - 15, 2018

Discount Deadline Date:
 August 20, 2018

Company Name _____ Email _____ Phone Number _____ Booth Number _____



Easy Ordering Tips:

- **Sign and/or truss points exceeding 300 lbs. will require a hoist .**
- GES is responsible for assembling and hanging all truss. However, your company may have a representative available at the time of installation. If no one is present at the pre-arranged time, GES will install your truss on your behalf with GES supervision. GES will operate all lifts.
- Delivery and rental is included in price. Motor outlets are not included with hoists or rotators.

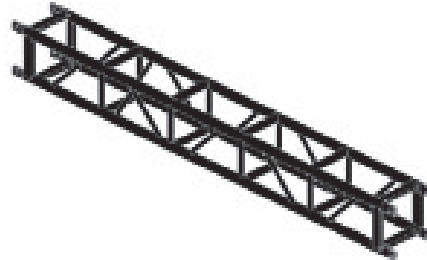

Order Chain Hoists, Motors, Truss and Lighting

CM Lodestar Chain Hoists

Item Code	Description	Discount (\$)	Regular (\$)	Qty	Tax %	Total
702133	Hoist, Electric Chain, 1 TON	624.25	800.50		6.0	\$
702132	Hoist, Electric Chain, 1/2 TON	530.50	680.25		6.0	\$

Rotating Motors

Item Code	Description	Discount (\$)	Regular (\$)	Qty	Tax %	Total
609107	Rotating Motor 100#	217.50	304.00		6.0	\$
609106	Rotating Motor 250#	289.25	404.50		6.0	\$

Tomcat Aluminum Truss

Item Code	Description	Discount (\$)	Regular (\$)	Qty	Tax %	Total
608132	Truss, 12" Box, Silver, Per Foot	24.35	31.25		6.0	\$
608136	Truss, 12" Corner Block, Silver	181.00	232.25		6.0	\$

Lights

Item Code	Description	Discount (\$)	Regular (\$)	Qty	Tax %	Total
700361	Floodlight, 1000 Watt Overhead*	568.25	728.50		6.0	\$
↳	*Please include Booth Layout form (H-3) for placement of overhead light.					
700350	Floodlight, 120 Watt	128.50	128.50		6.0	\$
↳						
700352	Floodlight, 120 Watt Double	222.00	222.00		6.0	\$
↳						

083600172

080118

H-5 050616 Cstm

Total and Sign: Return to Fax: (866) 329-1437 • International Fax: (702) 263-1520

Please Sign

X

Authorized Signature

Authorized Name - Please Print

Date

I agree in placing this order that I have accepted GES Payment Policy and GES Terms & Conditions of Contract, including authorization for GES to retain personal information to better serve my need for GES services at future events.

Total Payment Enclosed

\$

Cancellation Policy: Items cancelled will be charged **50%** of original price after move-in begins and **100%** of original price after installation

H-5 050616 Cstm 080118 083600172



Notice of Intent to Use EAC and Policies and Procedures

All orders are governed by the GES Payment Policy and GES Terms & Conditions of Contract as specified in this Exhibitor Services Manual.

Natural Products Expo East / All Things Organic™ BioFach America
Baltimore Convention Center
September 13 - 15, 2018

Form Deadline Date:
August 10, 2018

Company Name _____ Email _____ Phone Number _____ Booth Number _____



Attention:

- **This form must be completed by the Exhibitor only. An EAC cannot complete this form on behalf of the exhibitor.**

An Exhibitor Appointed Contractor (EAC) is a company other than the "general or official" service provider on the show that requires access to your booth during installation and dismantling. The EAC may only provide services in the facility that are not designated by the facility as "exclusive" to a designated provider, or by the show organizer in a contract as an exclusive service for the "general or official" service provider or other third party.

No EAC will be allowed to work in an exhibitor's booth if this Notice of Intent to Use EAC and Policies and Procedures form, a valid Certificate of Insurance and the Agreement, and Rules and Regulations between GES and the EAC form is not completed by an authorized representative and received by GES by the deadline indicated above. This Notice of Intent to Use EAC and Policies and Procedures form must be completed for every third party (as well as any other third party ordering or requesting services from GES on behalf of exhibitor) at the above show. Multiple booths are not to be listed on one form.

Exhibitor Appointed Contractor: _____

Contact Name: _____ Cell Phone: _____

Street Address: _____ Email: _____

City: _____ State: _____ Zip/Postal Code: _____

Office Phone: (area code) _____ Fax: (area code) _____

Description of proposed service for Exhibitor: _____

This form will only be accepted if it is executed by an authorized representative of the exhibiting company, and must include:

- An executed Agreement and Rules and Regulations between GES and EAC.
- A valid certificate of insurance prepared by the EAC's insurance agent with the minimum coverages as set forth in the Agreement and Rules and Regulations between GES and EAC.
- PLEASE NOTE: All Certificates of Insurance must be uploaded through CertFocus here: <https://beta.certfocus.com/expresso>
*There is a \$21.00 service fee per upload, this fee also applies if the certificate is mailed to GES

Please
Sign

X

Authorized Exhibitor Signature

Authorized Exhibitor Name - Please Print

Date

Review and Return Return to Fax: (866) 329-1437 • International Fax: (702) 263-1520

GES shall have no liability to any party for damage or injuries caused by exhibitor or its third party agents. It is the Exhibitor's responsibility to provide its EACs with all show rules and regulations as set forth in the exhibitor space lease and the Exhibitor Services Manual. Exhibitor agrees to indemnify and defend GES for the actions of its agents and exhibitor appointed contractors. The Exhibitor agrees that it is ultimately responsible for all services in connection with the exhibit, including freight, rentals and labor. Exhibitor agrees to be responsible for any losses, damages or injuries that are caused by or attributed to EACs that are not covered or provided by EAC's insurance.

080118 083600172

L-3 041918

Agreement and Rules and Regulations between GES and EAC

All orders are governed by the GES Payment Policy and GES Terms & Conditions of Contract as specified in this Exhibitor Services Manual.

Natural Products Expo East / All Things Organic™ BioFach America
Baltimore Convention Center
September 13 - 15, 2018

Form Deadline Date:
August 10, 2018

Company Name	Email	Phone Number	Booth Number
--------------	-------	--------------	--------------



Attention:

- **This form must be completed by the EAC.**

The undersigned Exhibitor Appointed Contractor (EAC) has been designated by an exhibitor to perform certain services for the exhibitor at the above referenced show. In consideration of the show organizer and GES permitting the EAC to perform such services at the show, the EAC and GES hereby agree as follows:

Rules and Regulations

1. EAC agrees to comply with all rules and regulations of the show as outlined in this agreement, the Exhibitor Services Manual, including all union rules and regulations, and accept liability for any negligent actions.
2. EAC agrees that it must ascertain and comply with all rules and regulations of the venue, Show Management, and/or the Official Service Provider in order to create a safe work environment. A failure to do so can result in a delay or termination of your right to continue work if the condition cannot be corrected.
3. EAC agrees that the show site, dock and surrounding areas are active work zones and the EAC, its agents, employees and representatives are present at their own risk. Entry into the dock area is prohibited.
4. EAC must have all business licenses and permits required by the State and City governments and the convention facility management prior to commencing work. A certificate of insurance naming GES as an additional insured with appropriate insurance limits prepared by the EAC's insurance agent must be submitted to GES at least 30 days prior to the first date of move-in.
5. This Agreement and Rules and Regulations between GES and EAC must be completed by an authorized representative of EAC and returned to GES before the deadline noted above.
6. If the EAC fails to provide the documentation required in paragraphs 4 and 5 above, the exhibitor will be required to use GES for such services at the prevailing rates set forth in the Exhibitor Services Manual.
7. EAC shall provide, if requested, evidence to GES that it possesses applicable and current labor contracts and must comply with all labor agreements and practices. The EAC must not commit or allow to be committed by persons in its employment any acts that could lead to work stoppages, strikes or labor problems.
8. EAC will be responsible for all reasonable costs related to its operation, including overtime pay for stewards, restoration of exhibit space to its initial condition, etc. Where applicable a one hour minimum labor charge will be charged at the appropriate steward rate of pay per day/per union to either the EAC/exhibitor depending upon the billing arrangement set up with GES (based upon EAC not number of booths).
9. The show aisles and public spaces are not part of the exhibitor's booth. Therefore, EAC is required to confine all activities to the exhibit space of the exhibitor who has given a valid order for services. Exhibitors may be charged for costs related to movement of its property if the EAC does not contain its operations within the confines of the booth. No service desks, storage areas or other work facilities will be located anywhere in the building. The show aisles and public space are not a part of the exhibitor's booth space and must be kept clear at all times.
10. During show hours, only EACs with exhibit badges will be permitted on the exhibit floor. No EAC will be permitted on the exhibit floor during show hours without the proper Convention name badge supplied by the exhibiting company. EAC must furnish Show Management and GES with the names of all on-site employees who will be working on the show floor and ensure that they have and wear identification badges at all times necessary as determined by Show Management.
11. EAC has uploaded certificates of insurance through CertFocus, confirming the following required insurance:
 - Commercial General Liability, including contractual liability, with limits of not less than \$1,000,000 each occurrence, \$2,000,000 general aggregate and \$2,000,000 products & completed operations aggregate.
 - Automobile Liability with a limit of not less than \$1,000,000 combined single limit - each accident. All owned, hired and non-owned boxes marked.
 - Workers Compensation, as required by law, with Employers Liability Limits of not less than \$1,000,000 each accident, \$1,000,000 disease - each employee and \$1,000,000 disease - policy limit.
 - Umbrella/Excess Liability with a limit of not less than \$1,000,000 each occurrence/aggregate.
 - All Policies (except Worker's Compensation) shall name GES (Official Service Provider), Informa (Show Management), Natural Products Expo East / All Things Organic™ BioFach America (Show) and Baltimore Convention Center (Facility) as additional insureds on a primary and non-contributory basis per the attached sample certificate of insurance. Umbrella follows form.
12. EAC agrees to indemnify, defend and hold the Show Management, the Facility and GES harmless from and against any and all claims, lawsuits, demands, liability, costs and expenses, including reasonable attorney's fees and court costs, arising out of EAC's operations, including supervision of GES provided labor. EAC also agrees to reimburse GES for all attorney's fees and costs incurred in connection with any and all claims, lawsuits and counterclaims that should arise out of EAC's failure to adhere to the terms of this agreement.
13. Solicitation of business on the show floor is strictly prohibited. If EAC attempts to provide services designated to another party as "exclusive" or is discovered soliciting on the show floor including the distribution of official company literature, or otherwise does not comply with the rules, the company may be removed from the show floor, and the exhibitor will not be able to use that company for the remainder of the event.
14. EAC/ exhibitor may not move freight from one booth to another booth, or to meeting rooms. GES must provide labor.
15. EAC must coordinate all of its activities with GES.
16. The exhibitor or its EAC should order services required from GES and the Exhibit Hall in advance. Ordering labor or services onsite (which contractors may not be prepared to provide immediately) may delay the set-up of your booth or force your set-up into overtime.

L-4 041918 080118 083600172

Agreement and Rules and Regulations between GES and EAC

All orders are governed by the GES Payment Policy and GES Terms & Conditions of Contract as specified in this Exhibitor Services Manual.

Natural Products Expo East / All Things Organic™ BioFach America
 Baltimore Convention Center
 September 13 - 15, 2018

Form Deadline Date:
 August 10, 2018

Company Name	Email	Phone Number	Booth Number
--------------	-------	--------------	--------------

Rules and Regulations (continued)

17. The exhibitor or its EAC should take steps to protect the exhibitor and the EAC's product in the booth by arranging for booth security and/or cages. GES is not responsible for items left unattended on the show floor.
18. EAC agrees GES is not responsible for any items stored in empty containers. Do not store empty cartons inside of empty crates. Cartons are returned from storage before crates so exhibitors may begin packing their product.
19. EAC/exhibitor agrees to keep "No Freight Aisles" clear at all times. If GES is required to rearrange any material situated in a clearly identified "No Freight Aisle," the exhibitor or the EAC depending upon the billing arrangements with GES will be charged a one hour minimum for forklift rental and labor.
20. EAC/exhibitor agrees that all outbound freight bills should be turned into the service desk on a timely basis. Holding freight bills until late in the day or turning in large amounts of freight bills to the GES Servicerenter at one time may delay outbound truck scheduling and subsequently force your loading out into overtime.
21. During tear down, pull all manageable structures back from aisle carpet lines. Electronics, mannequins, etc. should be placed in the center of the booth.
22. Be aware of vehicle traffic inside and outside of the facility. All attendees should be aware of their surroundings and all individuals are solely responsible for their own safety in parking lots, driveways, access roads and non-exhibit hall areas.
23. Label empty cartons and crates for storage as soon as they are ready. Holding back on "empties" only adds congestion to the aisles.
24. For services such as electrical, plumbing, telephone, cleaning and drayage, no service provider other than the Official Service Provider will be approved. This regulation is necessary due to licensing, insurance and work done on equipment and facilities owned by parties other than the exhibitor. Exhibitors shall provide only the material and equipment they own and those materials are to be used only in their exhibit space.
25. Smoking is prohibited in most facilities. Smoking shall only be allowed in designated areas.
26. This agreement is to be interpreted under the laws of the State of Nevada.
27. A faxed signature will serve as an original signature and will stand as a fully executed agreement once faxed to and received by GES.

Authorized Signature of EAC:

Please Sign _____
 Authorized EAC's Signature

_____ Date

Authorized EAC's Name - Please Print

Review and Return Return to: GES, 7000 Lindell Road, Las Vegas, NV 89118

Printed Name: _____

Title: _____

Company: _____

Address: _____ City: _____ State: _____ Zip/Postal Code: _____

Contact Name at Show Site: _____

Office Phone: _____ Cell Phone at Show Site: _____

Official Use Only	
Accepted by GES Authorized Representative:	
X	
Authorized Signature	_____
Authorized Name - Please Print	_____ Date

080118 083600172

L-4 041918



ACORD 1. **CERTIFICATE OF LIABILITY INSURANCE** DATE (MM/DD/YY)
01/01/18

PRODUCER ABC Insurance Agency Fax: (212) 555-6100 1234 Broker Lane New York, NY 10895 Attn: Joe Agent (212) 555-6102 ext. 1234	THIS CERTIFICATE IS ISSUED AS A MATTER OF INFORMATION ONLY AND CONFERS NO RIGHTS UPON THE CERTIFICATE HOLDER, THIS CERTIFICATE DOES NOT AMEND, EXTEND OR ALTER THE COVERAGE AFFORDED BY THE POLICIES BELOW. INSUREERS AFFORDING COVERAGE
---	---

INSURED 2. Big Boom Company, Inc. 1234 Corporate Lane New York, NY 10895 Attn: Joe Smith Phone: (212) 555-5349 Fax: (212) 555-9819	INSURER A: Hartford Insurance Company of Illinois INSURER B: Aetna Casualty & Surety Company INSURER C: Travelers Insurance Company INSURER D: Royal Insurance Company INSURER E:
---	---

3. THE POLICIES OF INSURANCE LISTED BELOW HAVE BEEN ISSUED TO THE INSURED NAMED ABOVE FOR THE POLICY PERIOD INDICATED, NOTWITHSTANDING ANY REQUIREMENT, TERM OF CONDITION OF ANY CONTRACT OR OTHER DOCUMENT WITH RESPECT TO WHICH THIS CERTIFICATE MAY BE ISSUED OR MAY PERTAIN, THE INSURANCE AFFORDED BY THE POLICIES DESCRIBED HEREIN IS SUBJECT TO ALL THE TERMS, EXCLUSIONS AND CONDITIONS OF SUCH POLICIES. LIMITS SHOWN MAY HAVE BEEN REDUCED BY PAID CLAIMS.

INSR LTR	4. TYPE OF INSURANCE	POLICY NUMBER	7. POLICY EFFECTIVE DATE (MM/DD/YY)	8. POLICY EXPIRATION DATE (MM/DD/YY)	9. LIMITS
A	GENERAL LIABILITY <input checked="" type="checkbox"/> COMMERCIAL GENERAL LIABILITY <input type="checkbox"/> CLAIMS MADE <input checked="" type="checkbox"/> OCCUR <input type="checkbox"/> _____ <input type="checkbox"/> _____ GENERAL AGGREGATE LIMIT APPLIES PER <input type="checkbox"/> POLICY <input type="checkbox"/> PROJECT <input type="checkbox"/> LOC	000P98298-A11	01/01/18	01/01/19	EACH OCCURRENCE \$1,000,000
	FIRE DAMAGE (Any one fire) \$ 50,000				
	MED EXP (Any one person) \$ 5,000				
	PERSONAL & ADV INJURY \$1,000,000				
	GENERAL AGGRREGATE \$2,000,000				
	PRODUCTS-COMP/OP AGG \$2,000,000				
B	AUTOMOBILE LIABILITY <input checked="" type="checkbox"/> ANY AUTO <input type="checkbox"/> ALL OWNED AUTOS <input type="checkbox"/> SCHEDULED AUTOS <input type="checkbox"/> HIRED AUTOS <input checked="" type="checkbox"/> NON-OWNED AUTOS <input type="checkbox"/> _____ <input type="checkbox"/> _____	SKLS-029499S	01/01/18	01/01/19	COMBINED SINGLE LIMIT \$1,000,000 (Ea accident)
	BODILY INJURY \$				
	(Per person)				
	BODILY INJURY \$				
	(Per accident)				
	PROPERTY DAMAGE \$ (Per accident)				
A	GARAGE LIABILITY <input type="checkbox"/> ANY AUTO <input type="checkbox"/> _____	XL1234567	01/01/18	01/01/19	AUTO ONLY-EA ACCIDENT
	OTHER THAN AUTO ONLY: \$ \$				
	AUTO ONLY: \$ \$				
A	UMBRELLA/EXCESS LIABILITY <input checked="" type="checkbox"/> OCCUR <input type="checkbox"/> CLAIMS MADE <input type="checkbox"/> DEDUCTIBLE <input type="checkbox"/> RETENTION \$	A4145-SS-PJ37	01/01/18	01/01/19	EACH OCCURRENCE \$1,000,000
	AGGREGATE \$1,000,000				
	\$				
	\$				
	\$				
C	WORKERS COMPENSATION AND EMPLOYERS' LIABILITY	A4145-SS-PJ37	01/01/18	01/01/19	<input checked="" type="checkbox"/> WC STATU-ORY LIMITS OTHER
	E.L. EACH ACCIDENT \$1,000,000				
	E.L. DISEASE-EA EMPLOYEE \$1,000,000				
	E.L. DISEASE -POLICY LIMIT \$1,000,000				
D	OTHER				Each Occurrence & Aggregate

5. **DESCRIPTION OF OPERATIONS/LOCATIONS/VEHICLES/EXCLUSIONS ADDED BY ENDORSEMENT/SPECIAL PROVISIONS**
 GES (Official Service Provider), Informa (Show Management), Baltimore Convention Center (Facility), and Natural Products Expo East / All Things Organic™ BioFach America (Show) are hereby named as additional insured, except for Workers' Compensation. GES and/or the consignor are included as Loss Payee. The insurance provided for the benefit of GES, shall be primary insurance as respects any claim, loss, or liability, arising out of the Named Insured's operations for which the Named Insured is liable. Any other insurance maintained by GES shall be excess and non-contributory. Show date(s) are: September 13 - 15, 2018 at city of Baltimore.

CERTIFICATE HOLDER	<input checked="" type="checkbox"/>	ADDITIONAL INSURED; INSURER LETTER: <input checked="" type="checkbox"/>	CANCELLATION
6. GES c/o CertFocus (web portal) National Service Center 7000 Lindell Road Las Vegas, NV 89118			SHOULD ANY OF THE ABOVE DESCRIBED POLICIES BE CANCELLED BEFORE THE EXPIRATION DATE THEREOF, THE ISSUING COMPANY WILL ENDEAVOR TO MAIL 30 DAYS WRITTEN NOTICE TO THE CERTIFICATE HOLDER NAMED TO THE LEFT, BUT FAILURE TO DO SO SHALL IMPOSE NO OBLIGATION OR LIABILITY OF ANY KIND UPON THE INSURER, ITS AGENTS OF REPRESENTATIONS AUTHORIZED REPRESENTATIVE <div style="text-align: right; margin-top: 10px;"> 10. </div>

1. **Producer:** Insurance Agent / Broker who issues certificate.
2. **Name of Insured:** Must be the legal name of contracting party.
3. **Types of Insurance:** Must include types required by contract. See General Information form in this Exhibitor Services Manual.
4. **Form of Coverage:** Must be "occurrence" form of coverage.
5. **Name of Additional Insureds:** GES (Official Service Provider), Informa (Show Management), Natural Products Expo East / All Things Organic™ BioFach America (Show) and Baltimore Convention Center (Facility) as additional insureds on a primary and non-contributory basis.
6. **Certificate Holder:** Must be GES
7. **Policy Effective Date:** Must be prior to or coincidental with the first day of Exhibitor Move-In.
8. **Policy Expiration Date:** Must be on or after the last day of Exhibitor Move-Out.
9. **Limits of Insurance:** Must be the same or greater than required by contract. See #11 on Agreement and Rules and Regulations between GES and EAC.
10. **Authorized Representative:** Must be signed (not stamped) by an authorized representative of Producer.

Submit Certificate of Insurance for EAC here: <https://beta.certfocus.com/expresso>
 *There is a \$21.00 service fee per upload, this fee also applies if this form is mailed to GES



080118 083600172 L-4 041918

GES Payment Policy

All orders are governed by the GES Payment Policy and GES Terms & Conditions of Contract as specified in this Exhibitor Services Manual.

Natural Products Expo East / All Things Organic™ BioFach America
Baltimore Convention Center
September 13 - 15, 2018

Payment for Services

GES requires payment in full at the time services are ordered. Further, GES requires that you provide a credit card authorization with your initial order. For your convenience, we will use this authorization to charge your account for services, which may include labor, material handling, or any applicable fuel or energy surcharges.

Discount Prices

To qualify for discount pricing, orders must be received with payment on or before the discount price deadline(s).

Method of Payment

GES accepts MasterCard, Visa, American Express, check and bank ACH/Wire transfer.

Purchase orders are not considered payment. All payments must be made in U.S. funds drawn on a U.S. Bank. Exhibitors will be charged a \$50.00 fee for returned NSF checks.

Third Party Billing

Each exhibiting firm is ultimately responsible for all charges incurred on its behalf. GES reserves the right to institute collection action against the exhibitor if the authorized third party does not pay. See Third Party Billing Request form.

Tax Exempt

If you are tax exempt in the state in which you will be exhibiting, you must provide a Sales Tax Exemption Certificate for that state. Please send the above information to the GES office for this show.

Taxes vary by location and will be added to your invoice if you do not submit your tax exempt certificate prior to the deadline.

Adjustments and Cancellations

No adjustments to invoices will be made after the close of the show.

Please refer to the individual forms for labor and furnishings for cancellation fees. All orders cancelled by the Exhibitor or due to the cancellation of an event or their non-participation may be subject to cancellation fees equal to 50% - 100% of the total order, based upon the status of move-in, work performed and/or GES set-up costs or expenses.

A minimum non-refundable deposit of \$25.00 will be applied towards the invoice, unless there is a cancellation of your order. Additionally, GES retains the right to implement/assess a fuel or energy surcharge on all services as necessary based upon market conditions.

083600172

080118

G-2p 100517

ORDER INSTRUCTIONS

Advance Payment Deadline Date: 08/20/18



The Power People

ELECTRICAL EXHIBITION SERVICES

One West Pratt Street, Baltimore, MD 21201
Phone: (410) 649-7321 Fax: (410) 649-7327
Baltimore@edlen.com

EXHIBITOR:		BTH #	
EVENT:	Natural Product—Expo East		
FACILITY:	BALTIMORE CONVENTION CENTER		
DATES:	September 13-15, 2018	EVENT #	098003BA

FOR YOUR CONVENIENCE PLACE YOUR ORDER ONLINE AT WWW.EDLEN.COM

COMPLETE THE STEPS BELOW TO PLACE UTILITY ORDERS

Step 1 Complete the Method of Payment

This form must be completed and returned with the order forms below.

Step 2 Complete Utility Order Forms as Required

- A. Electrical Order
- B. Plumbing Order

Step 3 Review Electrical Labor Instructions

This form will help you determine if you require electrical labor in your booth.

- A. What electrical work in your booth space needs to be performed by Edlen Electricians.
- B. How power is delivered to your booth in the facility (from the floor or ceiling).
- C. What other forms are required in order to schedule and pre-pay your estimated labor cost.

Step 4 Complete Additional Labor Forms as Required

Forms include the following:

A. Electrical Distribution

This form is used for the distribution of power on the floor in your booth space. The form should be completed by all island booths. Inline and peninsula booths need to provide this information only if power is required at any location other than the rear of the booth space.

B. Plumbing Distribution

This form is used for the distribution of air/water & drain services in your booth space. The form should be completed by all island booths. Inline and peninsula booths need to provide this information only if plumbing is required at any location other than the rear of the booth space.

Step 5 Complete the Electrical & Plumbing Layout Forms (if applicable)

All island booths must return an electrical layout and plumbing layout indicating a main distribution point as well as any other locations requiring power or plumbing services. Inline and peninsula booths need to return an electrical layout only if power is needed at any other location than the rear of the booth.

METHOD OF PAYMENT

Advance Payment Deadline Date: 08/20/18



The Power People

ELECTRICAL EXHIBITION SERVICES
 One West Pratt Street, Baltimore, MD 21201
 Phone: (410) 649-7321 Fax: (410) 649-7327
 Baltimore@edlen.com

EXHIBITOR:		BTH #	
EVENT:	Natural Product—Expo East		
FACILITY:	BALTIMORE CONVENTION CENTER		
DATES:	September 13-15, 2018	EVENT #	098003BA

FINANCIALLY RESPONSIBLE COMPANY

COMPANY NAME:		PHONE:
ADDRESS:		FAX:
CITY:	ST:	ZIP:
COUNTRY:	CELL #:	
EMAIL:		

METHOD OF PAYMENT

All transactions require a credit card on file with proper authorization. In addition to checks, Edlen also accepts American Express, Mastercard, Visa, Discover, ACH and Wire Transfers. Indicate form of payment below.

ACH ELECTRONIC PAYMENT TRANSFER

Wells Fargo ABA# 121000248 Acct: 4122636046
 3800 Howard Hughes Parkway, Las Vegas, NV 89169
 Phone: 800.289.3557

Please note the financial institution MUST be based in the US. In order to avoid a transfer fee, you must notify the financial institution that you wish to make an ACH electronic payment transfer.

BANK WIRE TRANSFER INFORMATION *

Bank transfer to Wells Fargo
Wire Transfer:
 ABA#: 121000248 Acct: 4122636046
International Wire Transfer:
 Swift Code: WFBIUS6S Acct: 4122636046

* Please reference the Event # listed above and your Booth # on all electronic payments.

* \$50 processing fee MUST be included with transfer.

CREDIT CARD

For your convenience, we will use this authorization to charge any remaining balances on your account prior to event closing. A copy of final charges will be sent to the email address provided in the payment information section.

VISA MASTERCARD AMEX DISCOVER

COMPANY CHECK

Make check payable to: Edlen Electrical. All foreign checks must be drawn on U.S. Banks only. Check must be received before the deadline date and you must include a credit card as a guarantee. Please reference the Event # listed above on your remittance.

CHECK AND CREDIT CARD INFORMATION

COMPANY NAME:															
CHECK #:															
CREDIT CARD NUMBER:												EXP DATE:			
CARD HOLDER SIGN:								PRINT NAME:							
EMAIL:															
THIRD PARTY PAYMENT? YES or NO															

CREDIT CARD ADDRESS INFORMATION IF DIFFERENT THAN INFORMATION ABOVE

ADDRESS:	CITY:	ST:	ZIP:
----------	-------	-----	------

SERVICE TOTALS

1. BANK WIRE TRANSFER PROCESSING FEE	
2. ELECTRICAL ORDER	
3. ESTIMATED LABOR	
4. LIGHTING ORDER	
5. PLUMBING ORDER	
TOTAL DUE	

AUTHORIZATION

AUTHORIZED SIGNATURE ABOVE	
PRINT NAME ABOVE	TODAY'S DATE ABOVE

By signing and placing this order, I accept all payment policies and the terms and conditions outlined on all completed service order forms.

ELECTRICAL ORDER



The Power People

ELECTRICAL EXHIBITION SERVICES

One West Pratt Street, Baltimore, MD 21201
Phone: (410) 649-7321 Fax: (410) 649-7327
Baltimore@edlen.com

E M

Advance Payment Deadline Date: 08/20/18

EXHIBITOR:		BTH #	
EVENT:	Natural Product—Expo East		
FACILITY:	BALTIMORE CONVENTION CENTER		
DATES:	September 13-15, 2018	EVENT #	098003BA

FOR YOUR CONVENIENCE PLACE YOUR ORDER ONLINE AT WWW.EDLEN.COM

ORDER INSTRUCTIONS

INLINE AND PENINSULA DELIVERY

The cost of 120-Volt outlets includes delivery to one location at the rear of inline or peninsula booths. If you require the outlet(s) to be distributed to any other location(s), material and labor charges apply. There is a minimum charge of (1) hour for installation and (1/2) hour for removal. Complete and return the Electrical Distribution Form along with a floor plan layout of your booth space indicating outlet location(s).

ISLAND BOOTH DELIVERY ONE LOCATION

Island booths that only need power delivered to one location incur (1) hour labor charge for installation and (1/2) hour removal charge. Return a floor plan layout of your booth space indicating the outlet location with measurements and orientation.

ISLAND BOOTH DELIVERY MULTIPLE LOCATIONS

Island booths that require power to be delivered to multiple locations within their booth space incur a minimum (1) hour labor charge for installation. The removal of this work will be charged a minimum (1/2) hour or (1/2) the total time of installation. Material charges will apply. Return a floor plan layout of your booth space indicating a main distribution point and all outlet locations with measurements and orientation. If a main distribution point is not provided, Edlen will deliver to the most convenient location.

208/480V POWER DELIVERY AND CONNECTIONS

Edlen electricians must make all high voltage connections and disconnections on a time and material basis. Complete the Electrical Booth Work Form to schedule your estimated connection time and labor. Return form with your order.

24 HOUR SERVICES

Electricity will be turned on within 30 minutes of show opening and off within 30 minutes of show closing, show days only. If you require power at any other time order 24 hour power at double the outlet rate.

CANCELLATIONS

Credits will not be issued for services delivered and not used. See #13, 19 & 20 on back of form for additional details.

TERMS & CONDITIONS

I agree in placing this order that I have accepted Edlen's payment policy and the terms and conditions of the contract.

ELECTRICAL OUTLETS Approximately 120V/208V A.C. 60 Cycle - Prices are for Entire Event

120 VOLT Exhibit Halls A-B & Ballroom	QTY Show Hours Only	QTY 24hrs/day Double rate	ADVANCE PAYMENT PRICE	REGULAR PAYMENT PRICE	TOTAL COST
500 WATTS (5 AMPS)	_____	_____	95.00	125.00	_____
1000 WATTS (10 AMPS)	_____	_____	120.00	150.00	_____
1500 WATTS (15 AMPS)	_____	_____	140.00	200.00	_____
2000 WATTS (20 AMPS)	_____	_____	170.00	220.00	_____
120 VOLT OTHER AREAS					
500 WATTS (5 AMPS)	_____	_____	99.00	150.00	_____
1000 WATTS (10 AMPS)	_____	_____	125.00	200.00	_____
1500 WATTS (15 AMPS)	_____	_____	145.00	230.00	_____
2000 WATTS (20 AMPS)	_____	_____	175.00	275.00	_____
208 VOLT SINGLE PHASE					
30 AMPS	_____	_____	355.00	490.00	_____
60 AMPS	_____	_____	550.00	700.00	_____
100 AMPS	_____	_____	900.00	1200.00	_____
200 AMPS	_____	_____	2,000.00	2,300.00	_____
208 VOLT THREE PHASE					
60 AMPS	_____	_____	725.00	950.00	_____
100 AMPS	_____	_____	1,250.00	1,580.00	_____
200 AMPS	_____	_____	2,300.00	2,900.00	_____

TRANSFORMER(S) Boost 208 Volt to 230 Volt ,

Transformer (20 amp minimum charge) Total Amps: _____ x 5.00 = _____

Please call for information on any services you require that are not listed here.

480V CONNECTIONS Approximately 480V A.C. 60 Cycle - Prices are for Entire Event

480 VOLT THREE PHASE			
30 AMPS	_____	1,160.00	1,740.00
60 AMPS	_____	1,518.00	2,277.00

120V RENTAL MATERIAL (Must Pick up Items at Onsite Exhibitor Service Center)

15' EXTENSION CORD	_____	26.00	_____
POWER STRIP	_____	26.00	_____

TRANSFER TOTAL TO BOX #2 ON METHOD OF PAYMENT FORM	TOTAL	_____
---	--------------	-------

PRINT NAME: _____

EMAIL: _____ PHONE: _____

TERMS & CONDITIONS

1. Order with payment & floor plan (for island booths or any booth requiring distribution of electrical services) must be received no later than the deadline date on the front of this form for advance payment rates to apply. Orders faxed or mailed without payment and required floor plan will not be guaranteed advance rates. Orders received after the deadline date will be charged at the regular rate. A purchase order or photocopy of a check are not considered valid forms of payment for securing advanced rate.
2. In the event order totals are calculated incorrectly, Edlen reserves the right to make the necessary corrections and charge the corrected amount. Exhibitors will be notified by email or fax of any such corrections.
3. Outlet rates listed include bringing services to one location at the rear of inline and peninsula booths.
4. Outlet rates listed **do not** include the connection of any equipment, special wiring, or distribution of the outlets, to other than the standard locations within the booth space. Distribution to all other locations *regardless of booth type* require labor and is performed on a time and material basis. Exhibitors are invited to contact the local Edlen office to discuss any additional costs that may be incurred.
5. A separate outlet must be ordered for each location where an electrical service is required. 5 amps or 500 watts is the minimum amount of power that can be ordered for any one location. Power must be ordered according to peak amperage ratings.
6. Island Booths - Booths that require power to be delivered to multiple locations within their booth space incur a minimum (1) hour labor charge for installation. The removal of this work will be charged a minimum (1/2) hour or (1/2) the total time of installation. Material charges will apply. Return a floor plan layout of your booth space indicating a main distribution point and all outlet locations with measurements and orientation. If a main distribution point is not provided, Edlen will deliver to the most convenient location.
7. There is a total (1) hour or (1/2) hour installation and (1/2) hour removal charge for Island Booths that require delivery to one location.
8. Labor rates are based on current wage scales and are subject to change in the event of a wage increase after rates have been published. A minimum charge of (1/2) hour labor will apply for all installation work. The removal of this work will be charged a minimum of 1/2 hour or 1/2 the total time of installation, plus material.
9. For a dedicated outlet, order a 20 amp outlet.
10. In the event 1000 watt overhead quartz lights cannot be mounted to existing catwalks in the convention hall, lift and labor charges will apply. Please contact our local office to discuss any additional charges.
11. Edlen employees are authorized to cut floor coverings when essential for installation of services unless otherwise directed.
12. Edlen is the exclusive provider of all material and equipment used in the distribution of temporary electrical services throughout the exhibit hall including the exhibitor booth space. This material is provided on a rental basis ONLY and remains the property of Edlen. It shall be removed only by Edlen employees.
13. Any extension cords or power strips ordered on the front of this form should be picked up at the Exhibitor Service Center. Credit will not be issued for unused items.
14. Standard wall and other permanent building utility outlets or sockets are not part of a booth space and may not be used by exhibitors unless electrical services have been ordered through Edlen.
15. All equipment regardless of source of power, must comply with federal, state and local codes. Edlen reserves the right to inspect all electrical devices and connections to ensure compliance with all codes, for which labor charges can be incurred. Edlen is required to refuse connections where the Exhibitor wiring or equipment is not in accordance with electrical codes.
16. All electrical equipment must be properly tagged and wired with complete information as to the type of current, voltage, phase, cycle, horsepower, etc., required for operation.
17. All Exhibitors' cords must be a minimum of 14 gauge, 3 wire and grounded. Two (2) wire extension cords are not allowed. All exposed, non-current carrying metal parts of fixed equipment which are liable to be energized, shall be grounded.
18. Payment in full must be rendered during the event. Exhibitors ARE NOT billed for services provided. Services may be interrupted if payment is not received.
19. Credit will not be given for services installed and not used. All orders are subject to a 25% cancellation fee if cancelled in writing & received by Edlen within 14 calendar days prior to show opening. Except sales tax, Edlen will not refund overpayment in amounts less than \$50.00 unless specifically requested in writing.
20. Claims will not be considered or adjustments made unless filed in writing by Exhibitor prior to the close of the event.
21. Exhibitor holds Edlen harmless for any and all losses of power beyond Edlen's control, including, but not limited to, losses due to utility company failure, permanent power distribution failure, power failure caused by vandalism, faulty Exhibitor equipment or overloads caused by Exhibitor.
22. It is agreed that in the event it becomes necessary to turn this matter over to an attorney for collection, or to file a lien, or foreclosure, or otherwise, Exhibitor will pay Edlen its attorney fees or applicable agency fees.
23. A service charge of 1.5% per month on any unpaid balances will be assessed starting 10 days after date of invoice. A \$25.00 service charge will be assessed for all returned checks and credit cards. Exhibitor agrees to reimburse Edlen for all applicable rental taxes.
24. By signing this and/or the Method of Payment form, exhibitor hereby agrees to all terms and conditions on this order form.

COMMONLY ASKED QUESTIONS - WHERE WILL MY OUTLET BE LOCATED?

Outlets are located as depicted below for inline & peninsula booths. All other locations require labor on a time & material basis. Exhibitors with hard wall booths must make arrangements with Edlen to bring power inside the booth on a time and material basis.

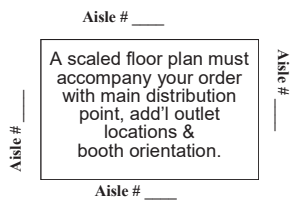
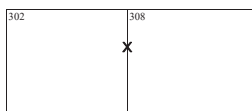
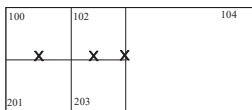

ISLAND BOOTHS

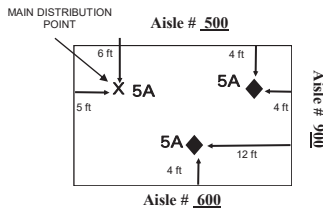

EXAMPLE-FLOOR POWER

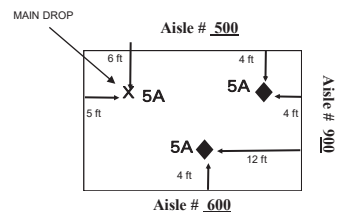

EXAMPLE-CEILING POWER

**FOR OTHER COMMONLY ASKED QUESTIONS VISIT OUR WEBSITE @ WWW.EDLEN.COM
OR CALL THE NUMBER ON THE FRONT OF THIS FORM**

ELECTRICAL LABOR INSTRUCTIONS

Advance Payment Deadline Date: 08/20/18



The Power People

ELECTRICAL EXHIBITION SERVICES
One West Pratt Street, Baltimore, MD 21201
Phone: (410) 649-7321 Fax: (410) 649-7327
Baltimore@edlen.com

EXHIBITOR:		BTH #	
EVENT:	Natural Product—Expo East		
FACILITY:	BALTIMORE CONVENTION CENTER		
DATES:	September 13-15, 2018	EVENT #	098003BA

LABOR ORDERING INSTRUCTIONS

Step 1 Review Jurisdiction Information Below

The work outlined under Electrical Jurisdiction below must be performed by Edlen Electricians and cannot be performed by any other union or I&D House. Determine the type of work required in your booth space and complete the corresponding labor forms. The Power Delivery section indicates if power typically comes from the ceiling or the floor which may impact your booth layout.

Step 2 Complete the Appropriate Form

There is a different form utilized to schedule labor in your booth space. This allows exhibitors to pre-pay the estimated labor cost. This is only an estimate. Final labor and/or lift cost may be greater or less depending on time required and minimum labor charges.

A. Electrical Distribution

This form is used for the distribution of power on the floor in your booth space. This form should be completed for all island booths. Inline and peninsula booths need to provide this information only if power is required at any other location than the rear of the booth space.

Step 3 Return the following forms to Edlen

Electrical Order, Method of Payment, applicable Labor Forms and Electrical Layout.

ELECTRICAL JURISDICTION

WORK REQUIRING EDLEN ELECTRICIANS

1. Delivery of main power line to Island Booths only
2. Electrical distribution under carpet or overhead
3. Connection of all high voltage services
4. Hardwiring of any electrical apparatus
5. Installation of lighting hung from ceiling
6. Assembly & installation of lighting hung from truss
7. Motor, truss, rigging installation and cabling

POWER DELIVERY

Power is typically delivered from the floor in this facility and is brought to one main distribution point. From this point it is distributed to all other locations in the booth space. Depending on the total power requirements an electrical panel may be placed at the main distribution point. Electrical panels utilize a minimum of 1'x1'6" floor space. Please call if you have any concerns.



The Power People

ELECTRICAL EXHIBITION SERVICES

One West Pratt Street, Baltimore, MD 21201
 Phone: (410) 649-7321 Fax: (410) 649-7327
 Baltimore@edlen.com

EXHIBITOR:		BTH #	
EVENT:	Natural Product—Expo East		
FACILITY:	BALTIMORE CONVENTION CENTER		
DATES:	September 13-15, 2018	EVENT #	098003BA

ELECTRICAL DISTRIBUTION UNDER CARPET

ALL Island booths MUST provide the information below. Inline and peninsula booths need to provide this information ONLY if power is required at any location other than the rear of the booth space. This information allows Edlen the opportunity to expedite move-in by having your power distribution complete prior to your scheduled move-in time. Complete all of the fields below including the "Labor Estimate" Section. Edlen will make every attempt to complete the work prior to your arrival, but it can not be guaranteed.

- Provide an Electrical Layout Form:
 - The electrical layout must indicate each power outlet and its location with exact measurements.
 - The electrical layout must reflect booth orientation. Use surrounding booth or aisle numbers.
 - Identify a main distribution point. Power is delivered to that point and then distributed to other locations. Inline or peninsula booths do not need to provide a main distribution point. Power will be located at the rear of the booth.
 - If power is only required in one location in Island booths, indicate that location with measurements on your electrical layout.
- What date will you begin building your booth?
 - Date: _____ Time: _____
- Will you be utilizing any specialty floor covering other than carpet, such as vinyl or wood?
 - Describe flooring: _____
 - Estimated date and time flooring installation will begin. Date: _____ Time: _____
- Show site supervisor:

Name _____ Cell # _____

Email _____ Company _____
- The exhibitor acknowledges there is a minimum 1 hour labor charge for the distribution of services and 1/2 hour for the removal of services. Island booths that only require power delivered to one location incur a 1 hour installation and removal charge.
- In the event a lift is required to deliver power from the ceiling, or if the exhibitor requests power be delivered from above when it's available on the floor, lift charges will apply for installation and removal. There is a minimum 1 hour installation and 1 hour removal cost for both lift and labor. For safety reasons lifts require a 2 man crew.

LABOR RATES AND HOURS		DISTRIBUTION LABOR ESTIMATE		
Labor Minimums	Enter a minimum of 1 hour for installation and 1/2 hour for removal. For installation labor greater than 1 hour, dismantle is 1/2 the total installation time.	MAN HRS	RATE	TOTAL
Straight Time	Monday - Friday, 8:00 AM - 4:30 PM, except Holidays.	ST	\$90.00	_____
Overtime	Monday - Friday 4:30 PM - 8:00 AM, all day Saturday, Sunday & Holidays.	OT	\$135.00	_____
		LIFT RENTAL		
		HOURS	RATE	TOTAL
		_____	\$250.00	_____

TRANSFER ESTIMATED TOTAL TO BOX #3 ON METHOD OF PAYMENT FORM	ESTIMATED TOTAL	_____
---	------------------------	-------

AUTHORIZATION

PRINT NAME: _____ DATE: _____

ELECTRICAL BOOTH WORK

Advance Payment Deadline Date: 08/20/18



The Power People

ELECTRICAL EXHIBITION SERVICES
 One West Pratt Street, Baltimore, MD 21201
 Phone: (410) 649-7321 Fax: (410) 649-7327
 Baltimore@edlen.com

EXHIBITOR:		BTH #	
EVENT:	Natural Product—Expo East		
FACILITY:	BALTIMORE CONVENTION CENTER		
DATES:	September 13-15, 2018	EVENT #	098003BA

BOOTH LABOR REQUIREMENTS

The date and times completed below assist Edlen in scheduling electrical manpower. These times and number of men are not guaranteed. Otherwise, all requests are performed on a first come first serve basis. A representative must come to Edlen's service desk prior to each individual labor request time in order to confirm the booth is ready for labor. If labor is dispatched at the requested time and no "exhibitor supervision" is available, a minimum 1/2 hour labor charge per electrician applies.

Hardwiring of any Device or Apparatus (Any electrical device that does not come with a plug attached)

Day _____ Date _____ Time _____ # Elec _____ Hrs. Each _____ Total _____

Connection of High Voltage Services (208V - 480V)

Day _____ Date _____ Time _____ # Elec _____ Hrs. Each _____ Total _____

Installation of Booth Lighting

Day _____ Date _____ Time _____ # Elec _____ Hrs. Each _____ Total _____

LIFT RENTAL

In the event a lift is required lift charges will apply for installation and removal. There is a minimum 1 hour installation and 1 hour removal cost for both lift and labor. For safety reasons lifts require a 2 man crew.

LABOR RATES AND HOURS		BOOTH LABOR ESTIMATE		
Labor Minimums	Enter a minimum of 1 hour for installation and 1/2 hour for removal. For installation labor greater than 1 hour, dismantle is 1/2 the total installation time.	MAN HRS	RATE	TOTAL
Straight Time	Monday - Friday, 8:00 AM - 4:30 PM, except Holidays.	ST	\$90.00	_____
Overtime	Monday - Friday 4:30 PM - 8:00 AM, all day Saturday, Sunday & Holidays.	OT	\$135.00	_____
		LIFT RENTAL		
		HOURS	RATE	TOTAL
		_____	\$250.00	_____

TRANSFER ESTIMATED TOTAL TO BOX #3 ON THE METHOD OF PAYMENT FORM	ESTIMATED TOTAL	_____
---	------------------------	-------

AUTHORIZATION

PRINT NAME: _____ DATE: _____

PLUMBING ORDER



The Power People

ELECTRICAL EXHIBITION SERVICES

One West Pratt Street, Baltimore, MD 21201
 Phone: (410) 649-7321 Fax: (410) 649-7327
 Baltimore@edlen.com

E M

Advance Payment Deadline Date: 08/20/18

EXHIBITOR:		BTH #	
EVENT:	Natural Product—Expo East		
FACILITY:	BALTIMORE CONVENTION CENTER		
DATES:	September 13-15, 2018	EVENT #	098003BA

FOR YOUR CONVENIENCE PLACE YOUR ORDER ONLINE AT WWW.EDLEN.COM

IMPORTANT NOTES

ADDITIONAL CONNECTIONS

If you have more than one machine or multiple connections on a machine, you must order an additional connection for each machine or connection within 20 feet of the outlet ordered. Otherwise you must order another outlet.

AIR LINE RESPONSIBILITIES

Edlen is not responsible for moisture, oil, or water in air lines, loss of flow, or increase in pressure in line to equipment. Exhibitor should supply their own filters, driers, or other equipment as needed. No compressors are permitted other than those supplied by Edlen unless they are a fixed part of your machine.

WATER PRESSURE

Pressure may vary. No guarantee can be made to minimum or maximum pressures. If pressure is critical, the Exhibitor should arrange to have a pressure regulator valve or pump installed. Edlen is not responsible for sediment, color or taste of water.

LABOR NOTES

OUTLET DELIVERY

There is a minimum labor charge of 1 hour to deliver and 1/2 hour to remove each air, water, and drain outlet. Outlets are delivered to the rear of inline and peninsula booths, and to one location in island booths. If a lift is required to drop the outlets from the ceiling, a 1 hour lift charge for installation and 1 hour for removal will apply.

OUTLET DISTRIBUTION

Once outlets have been delivered, the raming and/or distribution of services on the floor will be done on a time and material basis. A minimum 1 hour labor charge for installation and 1/2 hour for removal will apply.

OUTLET CONNECTIONS

Connection to exhibitor equipment is included in the cost of the service. Special equipment requiring company engineering or technicians for assembly, servicing, preparatory work and operation may be executed without Edlen plumbers.

TERMS & CONDITIONS

I agree in placing this order that I have accepted Edlen's payment policy and the terms and conditions of contract.

UTILITY SERVICES

ADVANCE REGULAR TOTAL

COMPRESSED AIR: 90-100 LBS. PSI

_____ Air Outlet (call for a quote for 24-hour Air)	225.00	315.00	_____
_____ Additional Connections within 20' of Outlet	184.00	276.00	_____

CFM REQUIREMENTS

Must order CFM with air services. Refer to # 9 on Plumbing Terms, Conditions & Regulations.

CFM (There is a 5 CFM minimum charge per outlet/connection)	Total CFM = _____
Total CFM _____ x ADVANCE Rate 7.00	= _____
Total CFM _____ x REGULAR Rate 9.00	= _____

WATER LINES (Edlen is not responsible for sediment or the color or taste of water.)

_____ Water Outlet	300.00	435.00	_____
_____ Additional Connections within 20' of Outlet	184.00	276.00	_____
# of connections required: _____ Size of connection: _____			
PSI required: _____ GPM Required: _____			

DRAIN LINES (If waste water contains hazardous materials, chemicals, or metals, Edlen cannot drain it.)

_____ Drain Outlet	130.00	275.00	_____
_____ Additional Connections within 20' of Outlet	184.00	276.00	_____
Number of connections required: _____ Size of connection required: _____			

FILL & DRAIN LABOR (Edlen is not responsible for sediment or the color of water)

_____ 1 – 50 Gallons	145.00	185.00	_____
_____ 51 – 200 Gallons	195.00	275.00	_____
_____ 201 – 500 Gallons	310.00	435.00	_____
_____ Each additional 100 Gallons up to 1,000 Gallons	50.00	70.00	_____

LABOR

Labor is required for all air, water, & drain lines, as well as distribution of services in your booth space or overhead. Complete the Plumbing Distribution form and include it with your order.

MISCELLANEOUS REQUIREMENTS (Call for a Quote)

TRANSFER TOTAL TO BOX #5 ON METHOD OF PAYMENT FORM	TOTAL	
---	--------------	--

PRINT NAME:

EMAIL:

PHONE:



The Power People

ELECTRICAL EXHIBITION SERVICES

One West Pratt Street, Baltimore, MD 21201
 Phone: (410) 649-7321 Fax: (410) 649-7327
 Baltimore@edlen.com

EXHIBITOR:		BTH #	
EVENT:	Natural Product—Expo East		
FACILITY:	BALTIMORE CONVENTION CENTER		
DATES:	September 13-15, 2018	EVENT #	098003BA

PLUMBING JURISDICTION

The work described below falls within the jurisdiction of Edlen Plumbers and cannot be performed by any other union, I&D house or exhibitor. Contact our office for clarification regarding scope of work.

- Delivery of Air, Water and Fill & Drain lines
- Installation of lines delivered from overhead
- Distribution of Air, Water & Drain lines under carpet

1. REVIEW EACH SECTION AND COMPLETE LABOR ESTIMATE

A. Outlet Delivery & Removal

There is a minimum 1 hour labor charge for the delivery and 1/2 hour for the removal of each air, water and drain service. If a lift is required to drop services from overhead, a minimum 1 hour for installation and 1 hour for removal will apply.

B. Outlet Distribution Throughout Booth Space

Air, Water and Drain lines are brought to one location at the rear of inline, peninsula and island booths. There is a minimum 1 hour labor charge for distribution and 1/2 hour for removal, or 1/2 the total time of installation, whichever is greater.

C. Outlet Connections

Connection to exhibitor equipment is included in the cost of the service.

2. DISTRIBUTION OF SERVICES IN BOOTH SPACE

A. Island Booths need to provide the following information:

1. The plumbing layout must indicate each outlet and its location with exact measurements.
2. Each location should indicate the type of service. All air locations must include CFM requirements.
3. The plumbing layout must reflect booth orientation. Use surrounding booth or aisle numbers.
4. Identify a main distribution point. Services are delivered to that point and then distributed to other locations.

B. Inline or Peninsula booths must provide the same information with the exception of the main distribution point. The main distribution point will be located at the rear of the booth space.

C. Date you will begin building your booth: _____ **Estimated time:** _____

D. Will you be utilizing any specialty floor covering other than carpet, such as vinyl or wood?

1. Describe flooring: _____

E. What time do you estimate needing the physical connection to your equipment? Date: _____ **Time:** _____

F. Show site supervisor: _____ **Company:** _____

Cell #: _____ **Email:** _____

G. This information allows Edlen the opportunity to expedite move-in by having your plumbing distribution complete prior to your scheduled move-in time. Complete the "Labor Estimate" Section below. Edlen will make every attempt to complete the work prior to your arrival.

LABOR ESTIMATE		
MAN HOURS	RATE	TOTAL
_____ ST	\$90.00	_____
_____ OT	\$135.00	_____
_____		_____

ESTIMATED TOTAL	_____
------------------------	-------

TRANSFER ESTIMATED TOTAL TO BOX #3 ON THE METHOD OF PAYMENT FORM

WORK RATE SCHEDULE	
ST	Monday - Friday, 8:00 AM - 4:30 PM, except Holidays.
OT	Monday - Friday 4:30 PM - 8:00 AM & all day Saturday, Sunday and Holidays.

AUTHORIZATION

PRINT NAME: _____

DATE: _____

PLUMBING TERMS, CONDITIONS & REGULATIONS

1. Order (with payment) must be received a minimum of 21 days prior to the scheduled event opening for advanced payment rates. Orders received without payment will not guarantee advance rates. Orders received less than 21 days prior to scheduled event opening will be charged the regular rate.
2. In the event that totals are calculated incorrectly, Edlen reserves the right to make the necessary corrections. Exhibitors will be notified by email or fax of any corrections made. This includes adding the required minimum CFM charges when applicable and labor charges.
3. All outlets will be installed on the floor at the back wall of inline and peninsula booths. All services ordered for island booths will be dropped to one location in the booth. Edlen will make every attempt to deliver these services to a location convenient to the exhibitor.
4. Distribution of services throughout the booth space, whether under the carpet, above the carpet or overhead is done on a time and material basis. Lift charges may also apply for overhead distribution.
5. Labor charges apply when an exhibitor requires services to be dropped from overhead when services originate on the floor or columns.
6. The CFM requirements (Cubic Feet per Minute) determine the volume of air required to properly operate exhibitors equipment. CFM is a labor charge for sizing and installation of the service infrastructure.
7. In some instances a pump is required to drain services out of an exhibitor's booth. When this occurs, time & material charges apply. Exhibitors are encouraged to contact Edlen to discuss any potential additional costs.
8. Connection to exhibitor equipment is included in the cost of the service. Special equipment requiring company engineering or technicians for assembly, servicing, preparatory work and operation may be executed without Edlen plumbers.
9. Service outlet size is determined by the volume required. Air line size is dictated by the CFM requirements and air line terminations vary.
10. Compressed Air is supplied during show hours only. If compressed air is required for non-show hours call for a quote.
11. Wall, column and permanent building utility outlets are not part of booth space and are not to be used by exhibitors.
12. Unless otherwise directed, Edlen personnel are authorized to cut floor coverings to permit installing service(s) ordered.
13. Pressure for Water Services may vary. No guarantee can be made of minimum or maximum pressure. If pressure is critical, the exhibitor should arrange to have a pressure regulator valve installed.
14. Natural Gas "when available" is not regulated by Edlen and is at the facility pressure. Call for price quote when available.
15. Gas & Cylinders "when available" 1025 - 1030 BTU per cubic foot at 7' water column pressure. Credit will not be provided on unused cylinders.
16. All equipment using water must have inlet and outlet properly tagged.
17. All equipment must comply with state and local codes.
18. Edlen will not be responsible for moisture or water in air lines. Exhibitors should supply their own filter or other equipment to handle moisture or water.
19. For gas cylinders or any other special requirements call Edlen for a quote at the number on the front of the form. Delivery charges will apply to any specialty equipment delivered and removed from the exhibitor booths.
20. Edlen must have 30 days notice in order to supply special regulators, strainers, traps, etc..
21. Claims will not be considered or adjustments made unless filed by the exhibitor in writing prior to close of the event; no exceptions.
22. Credit will not be given for outlets installed or connections made and not used.
23. Payment in full for all plumbing services provided must be made in full prior to close of the event.
24. It is agreed that in the event it becomes necessary to turn this matter over to an attorney for collection, or to file a lien, or foreclosure, or otherwise, exhibitor will pay Edlen its attorney fees or applicable agency fees.
25. A service charge of \$25.00 will be assessed for all returned checks or declined credit cards.
26. A service charge of 1.5% per month on any unpaid balances will be made starting 10 days after date of invoice.

**POWER TO OPERATE ANY PLUMBING APPARATUS IS NOT INCLUDED.
ALL ELECTRICAL REQUIREMENTS MUST BE ORDERED ON THE ELECTRICAL FORM.**

For further information please visit our web site at www.edlen.com
or call the number on the Plumbing Order form

INTERNET-TELECOM SERVICE AGREEMENT

SHOW NAME:	SHOW DATES: ____ / ____ / ____ TO ____ / ____ / ____	MOVE IN DATE: ____ / ____ / ____
EXHIBITOR NAME:	ONSITE CONTACT/CELL#:	BOOTH/ROOM:
COMPANY BILLING NAME	BILLING ADDRESS:	
CONTACT:	EMAIL ADDRESS:	PHONE:

** Advance rates are applied to orders received WITH PAYMENT 15 days prior to the first show move-in date

SERVICES	QTY	ADVANCE*	STANDART	TOTAL
Internet - Network Services (10/100 Base T) - Shared				
1. Basic Shared Internet Service (up to 2 Mbps + 1 Private IP address)		\$995	\$1,325	
2. Additional Private IP Address per Device		\$135	\$165	
3. Wireless Internet Access per First Device (Up to 2Mb)		\$835	\$895	
4. Wireless Internet Access per Each Additional Device (Up to 2Mb)		\$135	\$165	
5. Wireless Internet Buyout	<i>Call (410) 649-7097 for quote</i>			
Internet - Network Services (10/100 Base T) - Dedicated				
1. Dedicated 3 Mbps + 5 IP addresses/No addl IP's available		\$3,395	\$4,225	
2. Dedicated 6 Mbps Line + 13 public IP addresses/No addl IP's available		\$6,595	\$8,295	
3. Dedicated 10 Mbps Line + 29 public IP addresses/No addl IP's available		\$8,945	\$10,995	
4. Dedicated 15 Mbps Line + 29 public IP addresses/No addl IP's available		\$12,550	\$15,650	
6. Dedicated over 15 Mbps line + 29 public IP addresses	<i>Call (410) 649-7097 for quote</i>			
Other Internet - Network Services				
1. Switch Rental - unmanaged 8 Port 16 Port 24 Port		\$220	\$260	
2. Patch Cable (25-50' Cat 5)		\$45	\$60	
3. VLAN/Point-to-Point Connection		\$500	\$500	
4. Cable TV - Comcast (per connection)		\$315	\$470	
5. Technical Support (per hour with min 1 hour charge)		\$80	\$80	
Telephone Services				
1. Single Analog Line with Unlimited Local Services (PBX service dial "2" for outside line)		\$315	\$415	
2. Polycom Conference Phone		\$110	\$160	
3. Dedicated Analog Line (best for Credit Cards&Modem Services)		\$325	\$425	
4. Multi Line/Digital Line with Unlimited Local Services (PBX service dial "2" for outside line)		\$395	\$475	
5. Long Distance Capability? Yes No (indicate Qty of lines with LD)		<i>\$0.28 per minute</i>		
6. Telephone Handsets Required? Yes No		<i>free of charge</i>		
7. Voice Mail (per line)		\$20	\$20	
8. Call Forwarding (per line)		\$5	\$5	
9. Call Waiting (per line)		\$10	\$10	
10. ISDN BRI Line		\$645	\$795	
<ul style="list-style-type: none"> Credit-card users may fax their orders at 1-877-819-4023 or email to BCC_support@mcdean.com 3.5% fee will be applied for all credit card payment processing Checks must be made payable to M.C. Dean, Inc. and mailed to PO Box 532232, Atlanta, GA 30353 2232, Attention: Martin Husbands For online orders please use bcc.mcdean.com For service and order inquiries please call at 410-649-7097 	SUBTOTAL			
	6% TAX			
	3.5% FEE (applied to subtotal)			
	GRAND TOTAL			

All credit card charges will appear under the name "Openband". Payment in full is required prior to the event.

CREDIT CARD NUMBER:	EXP DATE: ____ / ____ / ____	SECURITY CODE:
CREDIT CARD HOLDER NAME:	CREDIT CARD HOLDER SIGNATURE AND ACCEPTING OF TERMS AND CONDITIONS:	DATE: ____ / ____ / ____

With execution of this document the Customer hereby authorizes M.C. Dean, Inc. to provide services as requested herein, is authorized to request such services and acknowledges full and complete understanding of Terms & Conditions. In case of using wireless services the Customer hereby attests to his or her understanding of limitations and vulnerabilities of the wireless services provided by M.C. Dean, Inc. as well as admits that in case of using this service for any reason including, but not limited to, demonstrating, showcasing or presenting own product(s), M.C. Dean will not be held liable for the possibility of interference.

<http://www.bccenter.org/downloads/files/MCDeanTerms.pdf>

■ **Order Audiovisual Online**

<https://psav.boomerecommerce.com> 

■ **See our Price List**



Products in our Online Store

23"-90" Monitors (wall-mount and floor stand installation available), SMART monitors, Touchscreen monitors, PC laptops, MacBook Pro, Mac Mini, iMac, 27" all-in-one touchscreens, iPad, Microsoft Surface, Wired Microphones, Wireless Microphones, Input Boxes, Audio Mixers, Personal Speakers

Place your order before **August 20th**, for 20% off

■ **Your Natural Products Expo East® Audiovisual Experts**

Online Product Recommendations: Carl Anderson | exhibits@psav.com | 800.966.4498

Custom Exhibit AV Needs: Jim Stuckeman | jstuckeman@psav.com | 214.210.8111

**ENGAGING
AV THAT
LEAVES A
LASTING
IMPRESSION**

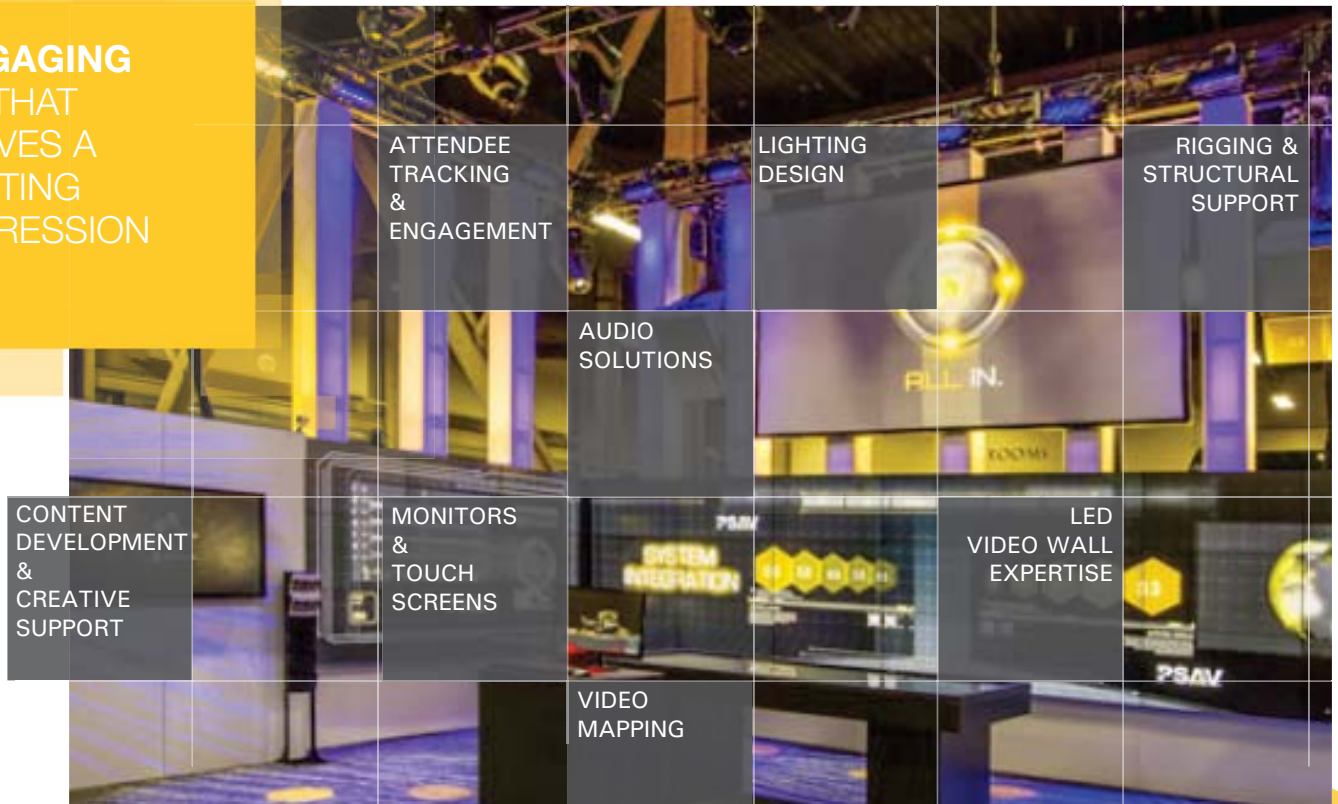

CONTENT DEVELOPMENT & CREATIVE SUPPORT

MONITORS & TOUCH SCREENS

AUDIO SOLUTIONS

VIDEO MAPPING

LIGHTING DESIGN

LED VIDEO WALL EXPERTISE

RIGGING & STRUCTURAL SUPPORT

Price List



Advanced Price Deadline: August 20th

Price Matching + No Drayage: With PSAV as the official AV provider for Natural Products Expo East®, you will never pay drayage on your audiovisual equipment. If you have preferred pricing with another vendor but would like to waive your drayage fees for AV, send us your quote and we'll price match your equipment costs.

AUDIO	Advanced Price / Standard Price	MONITORS / VIDEO	Advanced Price / Standard Price
Wired Microphone	75 / 95	32" Monitor & Floor Stand Combo	450 / 570
Wireless Microphone Kit	300 / 375	40"/42" Monitor & Floor Stand Combo	675 / 845
Countryman E6i Microphone Headset	125 / 155	55" Monitor & Floor Stand Combo	1000 / 1250
PC Direct Input Box	40 / 50	Laptop	343 / 490
10 Channel Audio Mixer	200 / 250	MacBook Pro	390 / 450
Individual Self Powered Speaker	225 / 280	MAC Mini Dual Core	350 / 435
Small Sound System	560 / 700	21.5" iMAC Dual Core	510 / 640
Large Sound System	745 / 930	Blu Ray / DVD Player	50 / 60
Computer Speakers	35 / 45	23"/24" LED/LCD Monitor	200 / 250
		32" LED/LCD Monitor	450 / 570
		40"-43" LED/LCD Monitor	600 / 750
		46"/48" LED/LCD Monitor	675 / 875
		55" LED/LCD Monitor	1000 / 1250
		65" LED/LCD Monitor	1300 / 1625
		70" LED/LCD Monitor	1650 / 2060
		27" All-In-One Touchscreen	600 / 750
		Distribution Amplifier	145 / 180
		Other:	
OTHER SOLUTIONS	Advanced Price / Standard Price		
Media Player	100 / 125		
Chrome Floor Stand	150 / 190		
Keyboard and Mouse - Wired	20 / 25		
Keyboard and Mouse - Wireless	50 / 65		
iPad	200 / 250		
iPad Desktop Stand	88 / 110		
iPad Floor Stand	88 / 110		
Microsoft Surface	270 / 340		
HP 400DW B&W Laser Printer	250 / 315		
15-Device WiFi Kit	1944 / 2430		
Showcase XD Digital Product Catalog	n/a / 1200		

3 Options for Placing your Order:

- Build a shopping cart at psav.boomerecommerce.com
- Save this locally and then email: exhibits@psav.com
- Call 800.966.4498 to speak to one of our helpful experts

* **Labor Disclaimer:** Listed prices do not include labor. Labor is calculated based on the total price of equipment (before tax) for each individual order. For orders of \$150+, there is a 30% labor fee (based on labor rates in Baltimore).



Natural Products Expo East Sampling, Shipping/Storage, Staffing and Food Prep

SAMPLING

Following the sampling guidelines set forth by NPEE, exhibitors may sample **non**-alcoholic food or beverage samples of products manufactured by the contracted company only (for alcoholic food or beverages – see guidelines listed below). **No cash sales are permitted.**

Exhibitors/Vendors sampling non-alcoholic food or beverage edible products do not need to send Centerplate any documentation (sampling form or certificate of liability insurance).

Exhibitors/Vendors sampling alcoholic food or beverage need to review the guidelines on page 2 and complete and submit all required paperwork.

Per current FDA regulations and New Hope Network exhibitor standards, no isolated or added Cannabidiol (CBD) is allowed in any dietary supplements or foods/beverages for consumption.

Centerplate and the Baltimore Convention Center do not assume any liability that may result from such consumption of these food and beverage products. The Exhibitor/Vendor sampling have sole responsibility for use and servicing by or other disposition of such times, in compliance with all applicable laws. Accordingly, the Exhibitor/Vendor agree to identify and forever hold harmless Centerplate and the Baltimore Convention Center from all liabilities, damages, losses, costs or expenses resulting directly from said sampling.

INDEX:

ALCOHOL SAMPLING GUIDELINES – see page 2-3

ALCOHOL SAMPLING FORM – see page 4

ALCOHOL ORDERING FORM – see page 5

FOOD PREP, SHIPPING AND STORAGE – see page 6 - 7

MISCELLANEOUS INFORMATION – see page 8

SUPPLY ORDER FORM – see page 9



Centerplate

Making It Better To Be There Since 1929.™

ALCOHOLIC FOOD & BEVERAGES SAMPLING GUIDELINES AND FORMS

Centerplate has exclusive food and beverage distribution rights within the Baltimore Convention Center to provide, control and retain all food and beverages services throughout the facilities for events including concessions, the service and sale of alcohol and non-alcoholic beverages, and to provide, control and retain any revenues therefore.

To avoid any misunderstanding, exact descriptions of alcoholic sample and portion size must be submitted to the Centerplate Catering Sales Office, along with necessary documentation, a minimum of 30 days prior to the event. **It is the Exhibitors responsibility to follow-up and ensure that all documentation has been received by Centerplate.**

Proper proof of insurance and signed Release & Indemnity Agreement that releases Centerplate and the Baltimore Convention Center from any liability related to this food and/or beverage must be provided by the customer, prior to arrival at the center. The firm named on the sampling form acknowledges they have sole responsibility for use, sale and servicing by or other disposition of such times, in compliance with all applicable laws. Accordingly, the firm agrees to identify and forever hold harmless Centerplate and the Baltimore Convention Center from all liabilities, damages, losses, costs or expenses resulting directly from said sampling. No cash sales are permitted by any exhibitors or conference.

SERVICE/SAMPLING OF ALCOHOLIC PRODUCT:

Per Maryland State Law, any alcohol to be sampled must be purchased by Centerplate thru a licensed Maryland Distributor and then resold to the exhibiting firm, even if you are the manufacturer or distributor of the product. The following policy resale charges applies:

- ☉ Liquor: \$5.00⁺ per bottle + distributor's invoice charge
- ☉ Wine: \$2.00⁺ per (760 ml) bottle + distributor's invoice charge
- ☉ Beer: \$1.50⁺ per (12oz) bottle/can + distributor's invoice charge

These charges cover the ordering, storage, cooling (if applicable) and one initial delivery to the booth (a re-stocking fee of \$60.00 per delivery will be assessed thereafter).

PLEASE RETURN THE COMPLETED ALCOHOL ORDER FORM (pg 5) WITH YOUR SAMPLING FORM (pg 4)

Any company/distributor that samples alcoholic beverages is **required** to use a TIPS certified Centerplate bartender for dispensing the product.

- ☉ A TIPS certified Bartender: fee of \$175.00⁺ plus tax for up to four (4) hours. Minimum of four (4) hours per Bartender. \$50.00 plus tax for each additional hour after initial four (4) hour period.

Please note that Maryland Alcoholic Beverage Commission regulates alcoholic beverages and services. Centerplate, as licensee, is responsible for the administration of these regulations.

- ⦿ No alcoholic beverages may be brought onto the premises from an outside source.
- ⦿ All alcoholic beverages being sampled must be ordered through Centerplate*.
- ⦿ No person under the age of 21 will be served alcoholic beverages. Samples are to only be served to persons 21 years of age or older. Each booth must provide a visible sign, stating: ***“Guests must be 21 years of age to participate in sampling of alcoholic beverages. Picture I.D is required”***
- ⦿ All alcoholic beverages must be dispensed by Centerplate bartender(s).
- ⦿ We reserve the right to refuse alcoholic beverage service to anyone who appears to be intoxicated or underage.
- ⦿ No alcoholic beverage may be removed from the premises.

ALCOHOLIC ITEM SAMPLING GUIDELINES:

- ⦿ ALL ITEMS LIMITED TO MANUFACTURER OF PRODUCT ONLY
 - **Alcoholic Beverages**
 - **Beer:** 4 oz
 - **Wine:** 2 oz
 - **Liquor:** ½ oz.
- ⦿ Items dispensed are limited to products manufactured, processed or distributed by exhibiting firm and must be directly related to the purpose of the show.
- ⦿ The firm named on the sampling form acknowledges they have sole responsibility for use, sale and servicing by or other disposition of such times, in compliance with all applicable laws. Accordingly, the firm agrees to identify and forever hold harmless Centerplate and the Baltimore Convention Center from all liabilities, damages, losses, costs or expenses resulting directly from said sampling. No cash sales are permitted by any exhibitors or conference.
- ⦿ Any food and/or beverage items, not manufactured by the exhibitor, **MUST BE PURCHASED FROM CENTERPLATE AT THE BALTIMORE CONVENTION CENTER.**
- ⦿ A Certificate of Liability Insurance, naming Centerplate and Baltimore Convention Center must be issued a minimum of seven (7) days prior to NPEE show open. Exhibitor shall obtain and maintain insurance for the entire period of providing samples in the amounts set forth in this section and shall provide to Centerplate a certificate of the following:
 - Liquor Liability: Not less than \$2,000,000 per person
 - Comprehensive General Liability: Not less than \$1,000,000
 - Workers' Compensation: As required by law.
 - Excess Liability: \$5,000,000.
- ⦿ Fees determined by Centerplate are applicable to all sampling distribution, selling and giving away of all items at the Baltimore Convention Center.



Centerplate

Making It Better To Be There Since 1929.™

ALCOHOLIC BEVERAGE SAMPLING FORM

PLEASE SEND THIS COMPLETED FORM WITH CERTIFICATE OF LIABILITY INSURANCE & ORDER FORM

Name of the Event: NATURAL PRODUCTS EXPO EAST

Sampling Date of Event: _____

Company Name: _____

Address: _____

City: _____ State _____ Zip _____

Telephone #: _____

E-mail Address: _____

Booth No: _____ Sampling Portion Size: _____

Contact _____ Title _____ Date _____

On-site Contact's Name: _____

On-site Contact's Cell Phone #: _____

Product(s) you wish to dispense (including descriptor):

I have read the Centerplate Sampling Policies and agreed to follow accordingly as an Exhibitor/Conference manager for the contracted dates of conference.

Signature _____

Centerplate General Manager Approval to Sample _____

Please complete the attached order form and either fax to (410) 649-7043 or email to:

main show exhibit hall: angela.kelly@centerplate.com

third and fourth level booths: katie.randall@centerplate.com

*°All prices above are subject to 6% Maryland State Tax & 9% Maryland State Alcohol Tax
+A 22% service fee and 6% state tax will be applied to all food & beverage orders.*

PLEASE SEND THIS COMPLETED FORM WITH CERTIFICATE OF LIABILITY INSURANCE & ORDER FORM

NPEE ALCOHOL SAMPLING ORDER FORM

All alcoholic beverages must be purchased and delivered to your booth by Centerplate

**Fees will be assessed per bottle depending on type of alcohol, plus the invoice price from the distributor*

Booth Name & #: _____

Order Item Brand/Type/Description	Quantity	Price*	Delivery Date	Delivery Times: drop-off, beginning & end		
Beer:		\$1.50 per bottle				
Beer:		\$1.50 per bottle				
Beer:		\$1.50 per bottle				
Beer:		\$1.50 per bottle				
Wine:		\$2.00 per bottle				
Wine:		\$2.00 per bottle				
Wine:		\$2.00 per bottle				
Wine:		\$2.00 per bottle				
Liquor:		\$5.00 per bottle				
Liquor:		\$5.00 per bottle				
Liquor:		\$5.00 per bottle				
Liquor:		\$5.00 per bottle				
Misc:						
Misc:						

BOOTH ORDERS MUST BE RECEIVED FOUR WEEKS PRIOR TO EVENT DATE*

Please complete the attached order form and either fax to (410) 649-7043 or email to:

main show exhibit hall: angela.kelly@centerplate.com

third and fourth level booths: katie.randall@centerplate.com

**All prices above are subject to 6% Maryland State Tax & 9% Maryland State Alcohol Tax
+A 22% service fee and 6% state tax will be applied to all food & beverage orders.*

PLEASE CALL TO CONFIRM RECEIPT

PLEASE SEND THIS COMPLETED FORM WITH CERTIFICATE OF LIABILITY INSURANCE & SAMPLING FORM

FOOD PREP, SHIPPING & STORAGE

FOOD PREP GUIDELINES

Please include the following information for your Centerplate food prep needs:

1. Company Name, Full Address, Phone and Fax Number.
2. What is the recipe for your product?
 - a. How much does 1 recipe make/serve?
3. What are the cooking instructions to prepare your product?
4. Ingredients
 - a. What ingredients are you providing for your product(s).
 - b. Will Centerplate need to provide any additional ingredients for your product?
5. Do you need to rent any basic equipment from Centerplate for your product or will you provide the pans for your product to go in?
6. Booth Information:
 - a. What is your booth number?
 - b. On-Site Contact's name and cell phone number?
 - c. Is this person authorized to order additional onsite food & beverage?
7. What are the dates and times for your product to be delivered to your booth?
8. How much of your product do you want delivered to your booth at each scheduled date/time?

SHIPPING & STORAGE

Exhibitors must arrange with Centerplate a minimum of 30 days prior to the event date to ensure space availability

- ☛ **Storage:** Centerplate will not receive any product for show sampling unless Centerplate will prep the food product. Please contact show management for product storage information. Centerplate will not assume responsibility for any product or items left in storage after the event date.
- ☛ **Shipping Dates:** FOOD PREP PRODUCT ONLY:
 - Product cannot be shipped to Centerplate before Wednesday September 6, 2017
 - Product must be shipped to Centerplate by Wednesday September 13, 2017.
 - A \$75.00+ per day storage fee will applied starting the day product is received.
 - It is the Company/Exhibitor's responsibility to follow-up that product has been received by Centerplate.
- ☛ **Shipping Hours:** Monday – Friday; 6:30am – 2:30pm
- ☛ **Shipping Address:**

Centerplate Receiving
c/o Baltimore Convention Center,
Loading Dock #15 or 16,
1 W. Pratt Street, Baltimore, MD 21201

☉ Shipping Information Required:

- Product must have your Company Name and Booth Number on the package as well as your booth number.
- Your product must be labeled properly with the correct storage instructions (refrigerator, freezer or dry storage) or Centerplate will not be liable for ruined product.
- Please provide a tracking number and estimated delivery date to Centerplate.

ADDITIONAL INFORMATION

- ☉ It will take Centerplate approximately 60 minutes to refresh additional onsite services.
- ☉ The Exhibitor must provide a table for catering services, as well as all equipment and/or serving utensils needed. All catering needs MUST fit within the booth space, aisle space is not available for use during a catered event for any reason.
- ☉ There will be designated dishwashing stations marked on the floorplan to clean your equipment. The main kitchen is not available to exhibitors.
- ☉ There will be a Centerplate service desk set-up onsite for any additional catering services that may come up onsite

DON'T FORGET

If you are sampling in your booth or on the show floor, you are responsible for providing:

- ☉ Electricity
- ☉ All equipment, including tables, heating equipment, serving utensils, cups, napkins, etc.
- ☉ Please call for rental equipment or to purchase supplies, order form included here.

FEES

- ☉ Staffing (all staffing needs, excluding Chefs, must be provided by Centerplate)
 - TIPS certified Bartender: fee of \$175.00⁺ plus tax for up to four (4) hours. Minimum of four (4) hours per Bartender. \$50.00 plus tax for each additional hour after initial four (4) hour period.
 - Banquet Server/Attendant: fee of \$150.00⁺ plus tax for up to four (4) hours. Minimum of four (4) hours per Attendant/Server. \$45.00 plus tax per Attendant/Server each additional hour after initial four (4) hour period.
- ☉ A delivery fee of \$60.00 is applicable for ALL deliveries to your booth. There will be a redelivery fee of \$60.00 for all deliveries not needed at the time of scheduled deliveries or if no one is at the booth to receive the delivery.
 - **Centerplate will not deliver products unless someone is in the booth to sign and receive it. It may take centerplate approximately 60 minutes to redeliver items.**
- ☉ Culinary labor fees will be assessed and calculated by the food prep that will need to be done, based on the recipe(s) and amount(s) needed.
- ☉ Labor fees and equipment rentals are subject to a 6% Maryland sales tax.
- ☉ All orders are subject to 22% Service Charge and 6% Sales Tax (unless otherwise noted).
- ☉ Orders made within seventy-two (72) business hours of the event or on-site orders are subject to a 20% surcharge

PAYMENT POLICY

Any unique or specialty orders can be accommodated, provided all arrangements and contracts are finalized four (4) weeks prior to the event date. All advance food and beverage orders must be accompanied by full payment either by credit card or company check (with a credit card on file for onsite additional items). PAYMENT MUST BE MADE IN FULL TO GUARANTEE SERVICES.

There is no credit/refund for unused product.

CANCELLATION

Cancellations made within seventy-two (72) business hours of the event will be assessed a charge of up to one hundred (100%) of the total order value, including fees and taxes. Cancellation of alcoholic beverages is subject to the distributors return policy.

CONTACT

We look forward to assisting you. Please contact your Centerplate Sales Coordinator with any questions or concerns you may have:

main show exhibit hall: angela.kelly@centerplate.com OR 410.649.7072

third and fourth level booths: katie.randall@centerplate.com OR 410.647.7075



Centerplate

Making It Better To Be There Since 1929.™

NPEE SUPPLY ORDER FORM

Our experienced Sales Department will gladly assist you with special requests.
Please call Angela Kelly at 410.649.7072 or Katie Randall at 410.649.7075 with any inquiries.

Company Name _____

Address _____ City: _____ State _____ Zip _____

Tel: _____ E-mail Address: _____

Booth No: _____ Contact _____

Order Item	Quantity	Charge	Delivery Date	Delivery Times*:		
				drop-off,	beginning &	end
20lb Bag of Ice (each)		\$ 40.00 ^a				
5 Gallon Water Bottle (each)		\$ 38.50 ^a				
Vinyl Disposable Gloves (100/box)		\$ 20.00 ⁺				
2oz Soufflé Cups (250/sleeve)		\$ 20.00 ⁺				
8oz Biodegradable Cold Cup (100/sleeve)		\$ 20.00 ⁺				
Biodegradable Spoons (50/pack)		\$ 20.00 ⁺				
Biodegradable Forks (50/pack)		\$ 20.00 ⁺				
White Cocktail Napkins (250/pack)		\$20.00 ⁺				
6" Biodegradable Plates (125/sleeve)		\$30.00 ⁺				
10.5" Disposable Tray (each)		\$20.00 ⁺				
Frill Picks (1000 count box)		\$15.00 ⁺				
Disposable Serving Utensil: (circle one) Spoon OR Fork		\$15.00 ⁺				
Disposable Chafers		\$25.00 ⁺				
Sterno (each)		\$60.00 ⁺				

BOOTH ORDERS MUST BE RECEIVED FOUR WEEKS PRIOR TO EVENT DATE

*A \$60.00 delivery fee will be applied to supply drop-off to each booth delivery

Please complete the attached order form and either fax to (410) 649-7043 or email to:

main show exhibit hall: angela.kelly@centerplate.com

third and fourth level booths: katie.randall@centerplate.com

^aAbove prices are subject to A 22% service fee and 6% Maryland State Tax

PLEASE CALL TO CONFIRM RECEIPT

Booth Monitor Order Form



Advance Order Deadline: August 20th, 2018

Show Management will provide reasonable security in the exhibit area during installation, show days, and dismantling, however many exhibitors elect to use Special Booth Monitoring Services. These services are available at the rate of \$30.00 per hour when this form and payment for ordered services are received on or before the above Order Deadline Date, and \$40.00 per hour for all orders after the above order deadline date. A six-hour minimum per shift per security monitor is in effect.

Payment in full must accompany order

Please indicate the dates and hours that you will require Special Booth Monitoring Services

Date & Time Start	Date & Time Finish	Total Hours	Date & Time Start	Date & Time Finish	Total hours
_____	_____	_____	_____	_____	_____
_____	_____	_____	_____	_____	_____
_____	_____	_____	_____	_____	_____
_____	_____	_____	_____	_____	_____
_____	_____	_____	_____	_____	_____

Total Number of Hours _____ @ \$ _____ Per Hours = \$ _____

Plus 3.5% Processing fee = _____ Grand Total = \$ _____

Security Personnel should remain in booth until released Yes No Exhibitor is responsible for additional charges

If not checked our personnel will leave your booth at the designated time

Please use the area on next page to list representatives who are authorized to release our personnel

Credit Card Number _____ Expiration Date _____ Visa

Cardholders Name _____

3 Digit Security Code on back of card: _____ 4 digit code if AMEX from front of card _____ MasterCard

Cardholders Billing Address _____ Amex

City/State _____ Zip Code _____ Corporate Card

Cardholders Signature: _____ Personal Card

Booth No _____ Company Name _____

Address _____

City _____ State _____ Zip _____

Telephone _____ / _____ / _____ Ext _____ Fax _____ / _____ / _____

Authorized Company Representative _____ Date _____

Email Address _____

****PLEASE COMPLETE THE NEXT PAGE****

As requested on the front side of this order form, the **contract security company** will provide special booth monitoring services and is authorized to enter said booth at all times necessary to perform their duties.

LIABILITY

It is understood that neither the **contract security company**, nor **show management**, or their **agents** is an insurer of persons and/or property. The CLIENT, if desired, shall obtain such insurance. Sums paid to the **contract security company** by the CLIENT are not related to the value of the CLIENT's property or to other property located on the CLIENT's premises. The sole intent of the **contract security company** is to provide a visible deterrent. The contract security company is being paid for services designed to deter certain risks or losses and all amounts being charged are not sufficient to guarantee that the service supplied will avert or prevent occurrences, or losses there from, for which the service is designed to deter or avert. The **contract security company** and its **subcontractors** shall not be liable to any extent whatsoever for any actual, potential or assumed loss of profits or revenues or for any collateral costs that may result from any loss or damage to CLIENT's material, which make it impossible or impractical to exhibit same. The CLIENT, as a result of this Agreement, does not seek indemnification from the **contract security company**, nor **show management**, or their **agents**, against any damages or losses caused by hazards to the CLIENT's property, or to the property or person of any third party while the **contract security company** is engaged in the execution of this Agreement. The signature on the other side of this form of the authorizing party requesting booth monitoring services also indicates acceptance of the conditions of this Agreement as stated above.

AUTHORIZED TO RELEASE SECURITY OFFICER / ON-SITE CONTACT

In the event of an emergency, it is requested that the following persons be notified on behalf of the CLIENT.

1. _____ Telephone _____ / _____ / _____
2. _____ Telephone _____ / _____ / _____
3. _____ Telephone _____ / _____ / _____
4. _____ Telephone _____ / _____ / _____
5. _____ Telephone _____ / _____ / _____
6. _____ Telephone _____ / _____ / _____



Please send order and payment to:

DTA Security Services, LLC
6362 McLeod Drive, Suite 5
Las Vegas NV 89120
Phone: 702-650-2298
Fax: 702-920-8340
order@dtasecurityservices.com
Nevada PILB 1067



FLORAL EXPOSITIONS

1264 La Quinta Drive, Suite D Orlando, FL 32809
Email: orders@floralexpo.net Phone: 407-855-0339 Fax: 407-855-0242

PROFESSIONAL FLORAL (A TO Z): ORDER ON PAGE 4

<p>A1 4" square 4" round \$30</p>	<p>A2 4" round \$30</p>	<p>A3 \$30</p>	<p>B 5" w x 5" h \$50</p>	<p>C 5" w x 6" h \$75</p>	<p>D 6" w x 6" h \$50</p>	<p>E 5" w x 5" h \$45</p>
<p>F 8" w x 10" h \$75</p>	<p>G 5" w x 12" h \$45</p>	<p>H 8" w x 8" h \$75</p>	<p>I 8" w x 8" h \$95</p>	<p>J 8" w x 8" h \$50</p>	<p>K 12" w x 12" h \$95</p>	
<p>L 10" w x 14" h \$95</p>	<p>M 14" w x 12" h \$75</p>	<p>N 8" w x 18" h \$95</p>	<p>O 14" w x 12" h \$75</p>	<p>P 14" w x 14" h \$135</p>		
<p>Q 12" w x 18" h \$85</p>	<p>R 14" w x 10" h \$55</p>	<p>S 9" w x 6" h \$75</p>	<p>T 14" w x 12" h \$95</p>	<p>U 12" w x 18" h \$85</p>		
<p>V 20" w x 10" h \$150</p>	<p>X 6" w x 24" h \$120</p>	<p>Y 20" w x 30" h \$200</p>	<p>Z 36" w x 48" h \$250</p>	<p>W 18" w x 10" h \$150</p>		

Please call to create a custom design!

GREEN PLANTS 3FT – 8FT: ORDER ON PAGE 4

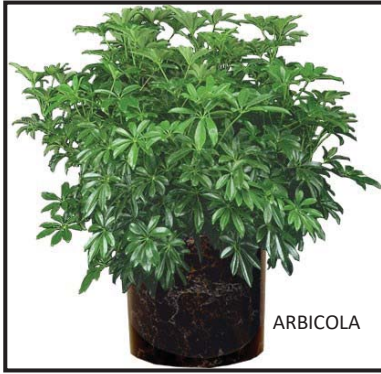

UPGRADED CONTAINER SELECTION: ORDER ON PAGE 4

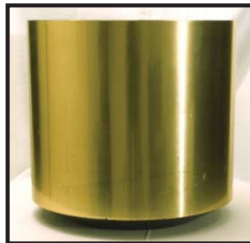

BLOOMING, FERNS, IVY & POTHOS: ORDER ON PAGE 4



CUSTOME OPTIONS: CALL FOR PRICING



FLORAL EXPOSITIONS

PROFESSIONAL FLORAL	Option (A to Z)	Cost	Quantity	Total
Fresh Floral (A thru Z)				
Fresh Floral (A thru Z)				
Customized Fresh Floral Arrangement	Color: Height: Width:			
Clear Bubble Bowl	8" For Business Cards	\$30.00		

Customized floral arrangements for hospitality suites, luncheons and banquets available.

GREEN PLANTS	Cost	Quantity	Total
3 Foot Green Plant	\$45.00		
4 Foot Green Plant	\$55.00		
5 Foot Green Plant	\$65.00		
6 Foot Green Plant	\$75.00		
7 - 8 Foot	\$16.00/ft		

Standard containers come with all plant orders. Indicate preference: **Black** _____ **White** _____
Please Call for Specialty Requirements on Topiaries, Exterior Plants, Large Trees, Andonidia Palms and More

UPGRADED CONTAINER SELECTION

TOTAL:

Dark Wicker _____ Green Marble _____ Mahogany Marble _____ Black Marble _____
White Marble _____ Brushed Brass _____ Brushed Chrome _____

*Small - \$5 _____ (Blooming Plants) *Medium - \$15 _____ (3 to 4 Ft. Plants) *Large - \$25 _____ (5 to 6 Ft. Plants)
Please call for specialty requirements such as Urns and Pedestal

BLOOMING, FERNS,	Color/Type	Cost	Quantity	Total
IVY & POTHOS	Fern _____ Ivy _____ Pothos _____	\$35.00		
Azaleas	Red _____ White _____ Pink _____	\$35.00		
Bromeliads	Red _____ Orange _____ Yellow _____	\$35.00		
Mums	Yellow _____ White _____ Lavender _____ Bronze _____	\$25.00		
Seasonal Blooming	Available Upon Request	Please Call		

DELIVERY/MAINTENANCE	\$15.00
SUB TOTAL	
6% SALES TAX:	
GRAND TOTAL:	

RETURN THIS ORDER FORM WITH YOUR PAYMENT TO FLORAL EXPOSITIONS INC.

SHOW NAME: NATURAL PRODUCTS EXPO EAST 2018 LOCATION: BALTIMORE CONVENTION CENTER
 SHOW DATES: SEPTEMBER 13-15, 2018 BOOTH#: _____ BOOTH REPRESENTATIVE: _____
 COMPANY: _____ ONSITE PHONE#: () _____ - _____
 CC BILLING ADDRESS: _____ CITY: _____ STATE: _____
 ZIP CODE#: _____ AUTHORIZED SIGNATURE: _____
 PAYMENT ENCLOSED: Check: _____ CC: _____ EMAIL ADDRESS: _____
 Credit Card#: _____ Expiration Date: _____
 Name of Credit Card Holder: _____ Security Code (CVV)#: _____

*If tax exempt, you must include your tax-exempt form for the state in which the show is being held.

EXHIBITOR - PLEASE RETAIN A PHOTOCOPY FOR YOUR FILES
CALL US 407-855-0339 or FAX US 407-855-0242 or EMAIL US orders@floralexpo.net

RENTAL POLICIES

- All materials and plants available on a rental basis only.
- Items missing from booth upon dismantling are the responsibility of the exhibitor and an additional charge will be applied.
- All prices include: servicing and removal at end of show.
- The availability of some items is subject to season and geography.
- Some specialty items must be ordered in advance to assure availability.

PAYMENT POLICIES

- Checks need to be drawn from a U.S. bank.
- All orders must be paid in full in U.S. currency prior to show date.
- Adjustments cannot be made after the close of the show.
- All orders are final 30 days prior to the show.

We will happily discuss and price your ideas or offer suggestions for unique, distinctive decorating.

_____ Enclosed is a photo or layout of our booth. Please have a designer contact me.
 _____ Please have a designer see us at our booth.

Date/Time _____ Representative _____ 190 _____

EXHIBITOR INSURANCE APPLICATION, USA

APPLICATION INFORMATION		Applicant Phone:	Applicant Fax:
Name of Business:			
Mailing address:	City	Province/State	Postal Zip Code
Email address - REQUIRED TO RECEIVE INVOICE AND CERTIFICATE OF INSURANCE:			
Describe in detail all products/services to be sold/offered by you at event:			

EVENT INFORMATION	
Name of Event Organizer (to be shown on certificate of insurance):	Event Name:
Address Of Event Organizer:	Event Location and Address:
City Province/State Postal/Zip Code	City Province/State Postal/Zip Code

EVENT DATES (Including Move In and Move Out):	FROM	dd mm yyyy	TO	dd mm yyyy
--	-------------	------------	-----------	------------

SCHEDULE OF COVERAGES

\$1,000,000 per occurrence, \$2,000,000 aggregate Limits: General Liability, Products and Completed Operations, Personal and Advertising Injury, Fire Damage Limit - \$300,000 and \$500,000 non-owned automobile liability coverage. Medical Expense not included. Subject to \$1,000 BI, PD and Expenses Deductible.

\$10,000 Inland Marine limit – covers your property while in transit to and from the Event Location (three days before and three days after the Event), and while on the Event premises. Subject to \$1,000 deductible.

Coverage is subject to underwriting review. Ineligible Risks: Food & Beverages, Alcohol, Amusement Devices, Athletic performances and stunts, Body piercing and permanent tattooing on site, Chemicals, E-Commerce selling on site, Fertilizers, Firearms, Fireworks Sales & Displays, Pyrotechnics, Games, Installation, Services or Repairs of products on Site, Live Animals, Medical Testing, On-site Equipment Sales/Rentals, Oxygen/Aromatherapy Bars, Pesticides, Pharmaceuticals, Nutraceuticals, Vitamins, Health or Dietary Supplements, Skin Care Products/Cosmetics, Time Share Sales, Tobacco Products, Licensed or Unlicensed Motorized Vehicles, Watercraft exhibits in water. **Note: There is no Liability coverage for Vehicles in Motion. Property excluded:** EDP (Electronic Data Processing), audio & video equipment, watches, jewellery made of precious or semi precious stones and/or precious metals, money, bullion, securities, stamps, antiques, furs, and fine arts.



I hereby appoint Brokers Trust Insurance Group Inc. as my authorized representative for this program. I am applying for insurance based on the information provided above. I hereby declare that all of the above is true and correct. With respect to this application or any change in coverages, I authorize you to collect, use and disclose information as permitted by law for the purposes necessary to assess the risk, investigate and settle claims, and detect and prevent fraud, and analyzing business results.

Please Print Your Name:	Signature:	DD	MM	YYYY
-------------------------	------------	----	----	------

The above insurance program will only be offered if the application form is signed and completed in full, and the payment and the application form are received in our offices prior to the opening show date. Completion of this application does not automatically bind coverage. We reserve the right to review all risks following online binding for underwriting compliance. **Premium and fee are minimum, retained and fully earned.** No refunds. Coverage is void if payment is returned N.S.F. NSF fee of \$50 will apply. A full copy of this policy is available upon request or online at www.exhibitorinsurance.com. A copy of the certificate is available to your Show Organizer upon their request.

PAYMENT INFORMATION: In US Funds ***Please indicate if you will be sampling food items to obtain correct coverage

▼ Please Select ►	No food sampling	With food sampling
\$1,000,000, per occurrence with \$2,000,000 aggregate, Liability Only	Premium + Fee = \$185	Premium + Fee = \$185
Liability same as above + \$10,000 Property Coverage	Premium + Fee = \$195	Premium + Fee = \$195
TOTAL ►	\$US	\$US

Payment type:	 	Card# _____	Exp Date: _____ mm/yy
If mailing a cheque, please remit payment to:	(The payment due on the Credit Card statement will be in the name of www.ExhibitorInsurance.com)		
Brokers Trust Insurance Group Inc. 2780 Hwy 7, Unit 103. Concord, ON L4K 3R9 Phone: 905-695-2971 Fax: 905-760-2260	Name of the Credit Card Holder: _____ Fill in your credit card billing address if it is different from mailing address above, to process your payment: _____		
Date: ____/____/____	Cardholder Signature _____ <i>I agree to pay above total according to my card issuer agreement.</i>		

The smart way to collect leads



App works with all iPhone, iPad and Android devices with this year's and the previous year's operating system.

CompuLEAD App

Download the app and activate it via a unique activation code on your own smart device

- Transfer activations between your staff's devices
- Custom qualifiers and survey questions
- Edit lead information and add notes
- Scan badges on and off the show floor even when cellular/Wi-Fi connection is lost
- Send your own marketing materials to your leads from the app
- Get personal in-booth training *Additional charges apply*
- Wireless printer *Additional charges apply*



CompuLEAD Tablet



Wireless Printer

CompuLEAD Tablet

A rental LG tablet equipped with the CompuLEAD app

- Custom qualifiers and survey questions
- Edit lead information and add notes
- Scan badges on and off the show floor even when cellular/Wi-Fi connection is lost
- In-booth delivery, setup and training *Additional charges apply*
- Wireless printer *Additional charges apply*



Program runs in iOS & Android Smartphones and Tablets

atEvent—Sync your leads to Marketing Automation and CRM systems

The atEvent event lead capture solution gives you the tools and insights you need to maximize sales conversions from events.

- Get event leads transferred into your Marketing Automation and CRM systems automatically
- Drive prospect nurturing and near real-time follow-up of sales-ready leads
- NO MORE SPREADSHEETS
- Add Scan badges and business cards
- Capture topics of interests and qualified follow up actions

compusystems.com/order

Packages	EARLY BIRD thru 8/20/18	STANDARD begins 8/21/18	QTY	TOTAL
CompuLEAD App 3 User Activations (115) • Custom qualifiers and surveys • 15 pieces of literature (15 PDFs, up to 5 MB each) • 5 links to videos	\$575	\$670	_____	\$ _____
+ Additional User Activations (173B)	\$130	\$130	_____	\$ _____
CompuLEAD Tablet (114) • Custom qualifiers and surveys • Wireless printer* • Delivery, setup and in-booth training • 15 pieces of literature (15 PDFs, up to 5 MB each) • 5 links to videos	\$715	\$880	_____	\$ _____
atEvent 3 User Activations (194) • Capture detailed prospect information • Marketing automation (Eloqua, Marketo, Hubspot, Pardot) or CRM (Salesforce.com) integration • Event intelligence and sales insights • More information at compusystems.com/atEvent.pdf	\$895	\$995		To order the atEvent option please call 708.786.5565
+ Additional User Activations (294)	\$130	\$130		
A-la-Carte				
CompuLEAD App 3 User Activations (173A)	\$455	\$555	_____	\$ _____
+ Additional User Activations (173B)	\$130	\$130	_____	\$ _____
CompuLEAD Tablet (174A)	\$455	\$555	_____	\$ _____
Add-ons				
Wireless Printer For App (287A) - Only pairs to 1 device/app at a time	+\$115	+\$150	_____	\$ _____
Wireless Printer For Tablet (187A) - Only pairs to 1 device/app at a time	+\$115	+\$150	_____	\$ _____
Setup and In-Booth Training For App (108)	+\$105	+\$140	<input type="checkbox"/>	\$ _____
Delivery, Setup and In-Booth Training For Tablet (08)	+\$105	+\$140	<input type="checkbox"/>	\$ _____
Payment				Subtotal \$ _____
				Processing Fee \$ 15.00
				TOTAL \$ _____
Contact Name/Title	Company Name	Booth # (Required)		
Address				
City	State	Zip Code	Country	
Phone	Onsite Cell	Fax		
Email	Alternate Email (to receive leads post-show)			
<p>Credit card deposit required for all rentals. Order will appear as LEAD RETRIEVAL on credit card statement. By signing this order form, I declare that I have fully read, understand and agree to abide by the Terms and Conditions listed below.</p> <p><input type="checkbox"/> Visa <input type="checkbox"/> MC <input type="checkbox"/> Amex</p>				
Card Number	Expiration Date			
Cardholder Name	Cardholder Signature			

All applicable taxes will be added
All prices in U.S. dollars.
All orders subject to a \$100 cancellation fee
No refunds after 8/14/18
No refunds on the CompuLEAD App
**Printer can only be paired to 1 device/app at a time.*

Order
compusystems.com/order
 Fax: +1 708.344.4444

For assistance
 Inside the U.S. (Toll-free): 866.600.LEAD (5323)
 Outside the U.S.: +1 708.786.5565





Attention Exhibitors

Using Your Own Badge Scanning Device?

CompuSystems, Inc. is the only company that has lead retrieval devices that provide exhibitors with real-time access to an attendee's full contact information that is stored in the barcodes on the attendee badges. The full contact information is encrypted in the barcode for security purposes and to ensure data integrity. CompuSystems has also made this full contact information available to exhibitors who are using their own lead retrieval devices.

If you plan on using your own hardware and/or software to capture sales leads at the event please be aware that the badges will have multiple barcodes.

QR Code

If you have your own device, make sure you read the QR Code on the badge. The QR Code contains the registrant's First Name, Last Name and Registration ID number. This data can be captured using your own device and using our online, self-service lead converter tool you can convert the data in your file to the full contact information that we have on file.



How do exhibitors using their own Lead Retrieval Devices get full registration contact information?

- If you have your own device and you want to receive full lead information via batch mode (not in real-time) you can convert the data in your file to the full contact information that we have on file using the new, self-service Lead Converter tool. The Lead Converter tool can be found on your Exhibitor Registration Dashboard or at www.compusystems.com/order.
- CSI also offers a lead converter Application Programming Interface (API) that will allow you to capture full contact information in real-time using your own devices.

Pricing for these services is available upon request. If you have any questions, please contact our Exhibitor Services Group at +1 708.786.5565.



LOWE

WORLDWIDE RENTAL SPECIALISTS



Worldwide
Rental Specialists In
Refrigerated, Frozen
& Hot Equipment

ABOUT US

Lowe Refrigeration, Inc opened in 1990 as an extension of our European Company for support of the trade show/convention industry in the United States. We have since provided our services beyond our Contracted Shows to include Non-Contracted Shows and Special Events. Lowe Refrigeration's equipment is housed in our Fayetteville, GA facility located approximately 20 miles south of Atlanta's Hartsfield Jackson International Airport. All orders are processed through this facility along with any required maintenance and repairs to our fleet of equipment. We have a complete inventory of spare parts and components which allows us to maintain the technical condition and cosmetic appearance of our equipment to the very high standards expected by our clients. With over 30 years of experience in refrigerations sales, exhibition, event, and corporate refrigeration rental, you can be certain that we will have the answers to all of your refrigeration requirements.

SERVICES

Contracted Shows:

Since 1990, Lowe Refrigeration, Inc. has been the show appointed "refrigeration contractor" shipping refrigerated display cases to the major food tradeshow across the United States. Lowe Refrigeration's staff are always onsite to offer the technical support and service necessary to ensure the success of your display. Order forms and color brochures are included in the tradeshow kits and can also be found on the show website as well as the Lowe Refrigeration website under "Trade Show Order Forms".

Non-Contracted Shows:

For any size show, expo, convention, or meeting Lowe Refrigeration, Inc. can offer a complete selection of equipment. Non-contracted shows differ from contracted shows, hence in order for Lowe Refrigeration to offer our range for these types of events, we ask that the client cover 50% of the round trip freight. Equipment in small quantity is usually shipped crated to ensure safe arrival to the show as well as the return to Lowe Refrigeration without damage. This allows our clients to have access to our entire range in any quantity, anywhere in the United States. Equipment orders of a larger quantity will usually be shipped as a full truckload, and a staff member from Lowe Refrigeration will be onsite in order to assist in the unload and reload of the equipment. Therefore, if you have a need for equipment in relation to a non-contracted show, keep us in mind. Forms for these events can be faxed or emailed by request.

Special Events:

Following the popularity and success of the Modular Cold Rooms that have been utilized by our locations in Europe and Asia, we decided to introduce the very same to the sporting event/hospitality world in the United States. Modular Cold Rooms (Refrigerators or Freezers) are available, 8ft by 8ft size and multiples thereof, for short-term and long-term rentals. Clean, quiet, electric powered units ensure your equipment will be free of loud engine noise and diesel fumes. Perfect for any indoor or outdoor occasion - sporting events, catered events, carnivals, private gatherings, emergency refrigeration needs, and so much more. Our rental division (trade shows/conventions) compliments our support of the event industry by making available copious amounts of refrigerated display equipment found throughout this brochure.

Call with your request and we will provide the rental package to suit your needs. Lowe Refrigeration, Inc. will work with you to provide what you want, where you want, when you want it!

Refrigerated 2 – 20

B Series 2	C Series..... 9	K Chillers 16
B - LG 3	Genova10	K3T Chiller 17
B Corner 4	Sara.....11	K Wood Chillers 18
Jinny 5	Mandy.....12	H1 19
P360° 6	Memphis13	G223 19
Oasis 7	Isola14	Starlet 19
F2 Chiller 8	G4T / G6T Chillers15	Prep 20

Bakery 21 – 25

B1P21	Victoria.....23	L Harmony..... 25
Kubo 500R 22	L Symphony.....24	

Wine Display 26

Bodega.....26

Frozen 27 – 41

K1T27	E230	DC8..... 37
K4TF27	E331	SS2P 38
VV17.....28	E432	SS2P 39
K4T28	D1C33	200GBT 40
G1T29	Kubo 500F34	H4IB 40
G6FT29	B2F.....35	Penguin..... 41
E130	F236	H2 41

Hot 42 – 48

Isola 4H42	MCTM.....45	DW 47
B1H43	CO25.....46	200 Hot..... 48
BR13H44	MW46	HSD2 48
MCT.....45	Top2.....47	

Non Refrigerated 49 – 52

I1.....49	MSU50	SSB3 52
I3.....49	HWS.....50	SSB1 52
MS12.....49	PTS51	
200 Dry49	PT51	

Cold Rooms 53 – 57

Ready Built Cold Room53	Modular Cold Room.....55	Modular Cold Room..... 57
Modular Cold Room54	Modular Cold Room.....56	

B Series



B - Back View

Features

- Automatic defrost
- Heater pan evaporation (no plumbing required)
- Built in preparation counter
- Castors supplied with case
- Easy to clean surfaces
- Forced air cooling
- Fully self contained unit
- Illuminated stainless steel display deck
- Rear access to display deck for server
- Refrigerated under-storage (accessed through rear doors with magnetic gaskets)
- Simple plug in operation
- Top hinged glass with hydraulic arm support for curved glass unit
- ABS foamed end walls
- Ice insert for fish display available upon request

* Display shelf available upon request (NOT refrigerated)

Specifications

Model Numbers

	B1	B2	B3
Width (inches)	52 ³ / ₈	77	101 ⁵ / ₈
Depth (inches)	43	43	43
Height (inches)	52 ¹ / ₂	52 ¹ / ₂	52 ¹ / ₂
Width without end walls (inches)	47	70 ¹ / ₄	94
Display area (square feet)	11	16 ¹ / ₂	22
Storage capacity (cubic feet)	5 ¹ / ₂	8 ¹ / ₄	10 ³ / ₄
Storage area width (inches)	47	70 ¹ / ₄	94
Storage area depth (inches)	20	20	20
Storage area height (inches)	10	10	10
Condensing unit size (HP)	1/3	1/3	1/2
Refrigerant	R404	R404	R404
Power supply v/Hz/Ph	120/60/1	120/60/1	120/60/1
Amps	20	20	20
Watts	2000	2000	2000
Deck fans	1	2	3
Temp Range	34/42°F or 1/6°C	34/42°F or 1/6°C	34/42°F or 1/6°C

Plug - each unit requires a single dedicated power supply; 24 hour power if keeping product in unit overnight.

B - LG
Low Glass Option
Self Service



B - LG Back View

Features

- Automatic defrost
- Heater pan evaporation (no plumbing required)
- Built in preparation counter
- Castors supplied with case
- Easy to clean surfaces
- Forced air cooling
- Fully self contained unit
- Illuminated stainless steel display deck
- Rear access to display deck for server
- Refrigerated under-storage (accessed through rear doors with magnetic gaskets)
- Simple plug in operation
- Ice insert for fish display available upon request
- ABS foamed end walls

Specifications

Model Numbers

	B1LG	B2LG	B3LG
Width (inches)	52 3/8	77	101 5/8
Depth (inches)	43	43	43
Height (inches)	38 1/4	38 1/4	38 1/4
Width without end walls (inches)	47	70 1/4	94
Display area (square feet)	11	16 1/2	22
Storage capacity (cubic feet)	5 1/2	8 1/4	10 3/4
Storage area width (inches)	47	70 1/4	94
Storage area depth (inches)	20	20	20
Storage area height (inches)	10	10	10
Condensing unit size (HP)	1/3	1/3	1/2
Refrigerant	R404	R404	R404
Power supply v/Hz/Ph	120/60/1	120/60/1	120/60/1
Amps	20	20	20
Watts	2000	2000	2000
Deck fans	1	2	3
Temp Range	34/42°F or 1/6°C	34/42°F or 1/6°C	34/42°F or 1/6°C

Plug - each unit requires a single dedicated power supply; 24 hour power if keeping product in unit overnight.

B Corner

90° Corner



'B' Corner - Back View



REFRIGERATED

Features

- Automatic defrost
- Heater pan evaporation (no plumbing required)
- Built in preparation counter
- Castors supplied with case
- Easy to clean surfaces
- Forced air cooling
- Fully self contained 90° corner
- Ice insert for fish display available upon request
- Illuminated stainless steel display deck
- Rear access to display deck for server
- Simple plug in operation
- Top hinged glass with hydraulic arm support for curved glass unit

Specifications

Model Numbers

	B Corner
Width (inches)	52 ½
Depth (inches)	52 ½
Height (inches)	50 ½
Width without end walls (inches)	50
Display area (square feet)	11 ½
Condensing unit size (HP)	½
Refrigerant	R404
Power supply v/Hz/Ph	120/60/1
Amps	20
Watts	2000
Deck fans	2
Temp Range	34/42°F or 1/6°C
Plug - each unit requires a single dedicated power supply; 24 hour power if keeping product in unit overnight.	

Jinny



Jinny - Back View



Features

- Bottom hinged glass
- Easy access for loading, setting of display and cleaning
- Simple disassembly for cleaning
- Castors supplied with case
- Euro style front and side glass
- Ice insert for fish display available upon request
- Illuminated stainless steel, display deck
- Rear access to the display for the server
- Under counter refrigerated storage
- Fully self contained unit
- Simple plug in operation
- Granite preparation counter built in
- Easy to clean surfaces and attractive lines
- ABS foamed end walls
- Magnetic door gasket for perfect seal
- Forced air cooling



J-150 Also Available In Black

REFRIGERATED

Specifications

Model Numbers

	J104	J150	J250
Width (inches)	41	59	99
Depth (inches)	36 ½	36 ½	36 ½
Height (inches)	50 ½	50 ½	50 ½
Display area (inches)	38 w x 26 ½ d	55 ½ w x 26 ½ d	95 ½ w x 26 ½ d
Display area (square feet)	7	10 ¼	17 ½
Condensing unit size (HP)	1/3	3/8	½
Refrigerant	R404	R404	R404
Power supply v/Hz/Ph	120/60/1	120/60/1	120/60/1
Amps	20	20	20
Watts	2000	2000	2000
Temp Range	34/42°F or 1/6°C	32/42°F or 0/6°C	32/42°F or 0/6°C

Plug - each unit requires a single dedicated power supply; 24 hour power if keeping product in unit overnight.

P360°

Grab & Go Island



Features

- 360° product visibility
- Forced air system
- Castors supplied with case
- Stainless steel deck
- Protective bumpers
- European appearance
- Digital thermostat
- Suitable for all refrigerated products
- Gray bottom panels
- Simple plug in operation
- Ice insert for fish display available upon request

REFRIGERATED

Specifications

Model Number

	P360°
Width (inches)	55 ½
Depth (inches)	47
Height (inches)	35
Display area (square feet)	12 ¼
Condensing unit size (HP)	1/3
Refrigerant	R404
Power supply v/Hz/Ph	120/60/1
Amps	20
Watts	2000
Deck fans	2
Temp Range	36/50°F or 2/6°C

Plug - each unit requires a single dedicated power supply; 24 hour power if keeping product in unit overnight.

Oasis

Sealed Deck, Suitable for Ice

Features

- Wooden finish
- Acrylic dome for 360° viewing
- Stainless steel display deck-sealed
- Suitable for ice
- Drain fitted
- Lid is raised electronically
- Self service with lid up
- Display with lid down
- Multipurpose display case
- Smooth finish and appearance
- Fully mobile
- Economical system
- Static evaporation system
- Very rapid pull down time
- Strong construction
- Efficient, quiet system
- Easy to clean surfaces and smooth lines
- Illuminated display
- Fully self contained
- Ozone friendly refrigerant
- Simple plug in operation with simple controls
- Thermostat control
- Operator friendly
- Castors supplied with case
- Spot display



REFRIGERATED

Specifications

Model Numbers

	Oasis 1	Oasis 2
Width (inches)	43	55
Depth (inches)	43	55
Height (inches)	52 closed / 68 raised	52 closed / 68 raised
Display area (square feet)	10 ¼	17 ½
Condensing unit size (HP)	1/3	1/3
Refrigerant	R134	R134
Power supply v/Hz/Ph	120/60/1	120/60/1
Amps	20	20
Watts	2000	2000
Deck fans	2	2
Temp Range	34/42°F or 1/6°C	34/42°F or 1/6°C

Plug - each unit requires a single dedicated power supply; 24 hour power if keeping product in unit overnight.

F2 Chiller



Features

- Modern, state-of-the-art styling
- Wear resistant black vinyl coated steel exterior with all stainless steel countertop and slide lids for lifetime durability
- Heavy duty, long lasting galvanized steel interior
- Front, rear and side venting louvers allow greater condenser air flow for tight fit installations
- Easily accessible and serviceable slide out condensing unit
- Automatic, energy saving, non-electric condensate disposal system with easily accessible, front mounted cleanout drainage hose and drain pan
- High density, non-CFC polyurethane foamed-in-place insulation

Specifications

Model Number

F2 Chiller

Width (inches)	64
Depth (inches)	27 ½
Height (inches)	37
Inside Height (inches)	27
Inside Width (inches)	60
Inside Depth (inches)	20
Storage capacity (cubic feet)	18 ¾
Condensing unit size (HP)	1/3
Refrigerant	R134
Power supply v/Hz/Ph	120/60/1
Amps	20
Watts	2000
Temp Range	34/42°F or 1/6°C

Plug - each unit requires a single dedicated power supply; 24 hour power if keeping product in unit overnight.

C Series

Euro Dairy/Deli Merchandiser
Adjustable Shelves

Features

- Open front – self service grab and go
- Easy access for loading and cleaning
- Excellent vision through attractively styled side glass
- White interior
- Four fully adjustable shelves
- Shelves can be angled
- Extra shelves available upon request
- Peg bars and pegs available upon request
- Energy saving self contained night blind
- Efficient, quiet system
- Castors supplied with case
- Fully self contained unit
- Simple plug in operation with simple controls
- No drain required (hot gas evaporation of defrost water)
- Impact resistant finish
- Pricing rails on each shelf
- Shelf product stoppers available upon request



REFRIGERATED

Specifications

Model Numbers

	C1	C2	C3
Width (inches)	39 ¾	52 ¼	77
Depth (inches)	34	34	34
Height (inches)	84	84	84
Width without end walls (inches)	36 ¾	49 ½	73 ½
Number of shelves	4	4	4
Shelf width x depth (inches)	36 ¾ w x 17 ½ d	49 ½ w x 17 ½ d	73 ½ w x 17 ½ d
Display area (inches)	36 ¾ w x 24 d	49 ½ w x 24 d	73 ½ w x 24 d
Display area (sq.ft.)	18 ¼	24	36 ¼
Condensing unit size (HP)	¾	¾	1 ⅛
Refrigerant	R404	R404	R404
Power supply v/Hz/Ph (unit)	120/60/1	120/60/1	
Amps (unit)	20	20	20
Watts (unit)	2000	2000	2000
Deck fans	1	2	3
Temp Range	35/42°F or 2/6°C	35/42°F or 2/6°C	35/42°F or 2/6°C

Plug - each unit requires a single dedicated power supply; 24 hour power if keeping product in unit overnight.

Genova

Open Front Merchandiser

Features

- Open front – self service grab and go
- Easy access for loading and cleaning
- White Interior
- Five fully adjustable shelves
- Additional shelves available upon request
- Peg bars and pegs available upon request
- Shelves can be angled
- Energy saving self contained night blind
- Efficient, quiet system
- Castors supplied with case
- Fully self contained unit
- Simple plug in operation with simple controls
- No drain required (hot gas evaporation of defrost water)
- Impact resistant finish
- Pricing rails on each shelf
- Glass or solid end walls
- Shelf product stoppers available upon request



REFRIGERATED

Specifications

Model Numbers

	Genova 1	Genova 2
Width (inches)	40 ½	52 ¾
Depth (inches)	35 ½	35 ½
Height (inches)	86	86
Width without end walls (inches)	37	49 ¼
Number of shelves	5	5
Shelf width and depth (inches)	36 ½ w x 17 ¾ d	49 w x 17 ¾ d
Display area (inches)	36 ½ w x 21 ¾ d	49 w x 21 ¾ d
Display area (square feet)	27 ½	37
Condensing unit size (HP)	1	1
Refrigerant	R404	R404
Power supply v/Hz/Ph (unit)	120/60/1	120/60/1
Amps	20	20
Watts	2000	2000
Deck fans	1	2
Temp Range	35/42°F or 2/6°C	35/42°F or 2/6°C

Plug - each unit requires a single dedicated power supply; 24 hour power if keeping product in unit overnight.

Sara

Open Front Merchandiser

Features

- Open Front – self service grab and go
- Easy access for loading and cleaning
- White interior
- 3 Fully adjustable shelves
- Additional shelves available upon request
- Peg bars and pegs available upon request
- Castors supplied with case
- Energy saving self contained night blind
- Efficient, quiet system
- No drain required (hot gas evaporation of defrost water)
- Pricing rails on each shelf
- Fits through single door
- Forced air cooling
- Shelf product stoppers available upon request



Specifications

Model Number

	Sara
Width (inches)	52 ½
Depth (inches)	27
Height (inches)	69
Width without end walls (inches)	49
Display area (square feet)	16.88
Top shelf (inches)	49 w x 7 d
Middle shelf (inches)	49 w x 10 d
Bottom shelf (inches)	49 w x 14 d
Bottom Deck (inches)	49 w x 18 ¾ d
Condensing unit size (HP)	¾
Refrigerant	R404
Power supply v/Hz/Ph	120/60/1
Amps	20
Watts	2000
Deck Fans	2
Temp Range	35/42°F or 2/6°C

Plug - each unit requires a single dedicated power supply; 24 hour power if keeping product in unit overnight.

Mandy

Open Front Merchandiser
Black or White



REFRIGERATED

Features

- Automatic defrost
- Castors supplied with case
- Easy to clean surfaces
- Fits through single door
- Forced air cooling
- Fully self contained unit
- Heater pan evaporation (no plumbing required)
- Illuminated top shelf
- Simple plug in operation
- Stainless steel shelves and display deck
- 3 shelves standard
- Energy saving self contained night blind

Specifications

Model Number

	Mandy 100
Width (inches)	39 1/2
Depth (inches)	29 3/4
Height (inches)	52
Width without end walls (inches)	36 1/2
Top shelf	34 3/4 w x 8 1/4 d
Middle shelf (inches)	34 3/4 w x 10 d
Bottom shelf (inches)	34 3/4 w x 12 d
Bottom Deck (inches)	35 1/4 w x 22 d
Display area (square feet)	13
Condensing unit size (HP)	3/4
Refrigerant	R404
Power supply v/Hz/Ph	120/60/1
Amps	20
Watts	2000
Deck fans	1
Temp Range	35/42°F or 2/6°C
Plug - each unit requires a single dedicated power supply; 24 hour power if keeping product in unit overnight.	

Memphis



Non-Refrigerated

Features

- Grab and Go refrigerated lower section
- Non refrigerated upper section
- Lockable Castors
- Sliding rear doors on upper section
- Glass shelf in upper section
- Fully mobile
- Smooth end walls
- Available in Black or Bronze
- No drain required (hot gas evaporation of defrost water)
- Efficient, quiet system

Refrigerated

REFRIGERATED

Specifications

Model Numbers

	Memphis 90	Memphis 120
Width (inches)	35 ½	47 ½
Depth (inches)	32 ¾	32 ¾
Height (inches)	56 ½	56 ½
Display deck (inches)	32 w x 22 d	44 w x 22 d
Display deck (square feet)	5	6 ¾
Condensing unit size (HP)	¼	¼
Refrigerant	R404	R404
Power supply v/Hz/Ph	20/60/1	120/60/1
Amps	20	20
Watts	2000	2000
Deck Fans	1	2
Temp Range	37/42°F or 3/6°C	37/42°F or 3/6°C

Plug - each unit requires a single dedicated power supply; 24 hour power if keeping product in unit overnight.

Isola

Features

- Internal basin in AISI stainless steel
- External in wood or stainless steel
- Gastronorm pans available upon request
- Different configurations available
- Pans available upon request
- Accepts deep or shallow pans
- Static refrigeration system
- Digital control panel
- Electronic lid for ease of loading/serving
- Castors supplied with case
- Serving trays optional
- LED lighting optional



REFRIGERATED

Specifications

Model Numbers

	Isola 4S/S	Isola 6	Isola 6S/S
Width (inches)	59 ¼	81 ¼	86
Depth (inches)	29 ½	29 ½	29 ½
Height (inches) top down	45	45 ¼	45
Height (inches) top up	59	59	59
Condensing unit size (HP)	⅓	⅓	⅓
Refrigerant	R134	R134	R134
Powers supply v/Hz/Ph	120/60/1	120/60/1	120/60/1
Amps	20	20	20
Watts	2000	2000	2000
Temp range	38/50°F or 3/10°C	38/50°F or 3/10°C	38/50°F or 3/10°C

Plug - each unit requires a single dedicated power supply; 24 hour power if keeping product in unit overnight.

Features

- For all chilled food products
- Fully self contained bottom mounted condensing unit
- Efficient, quiet system
- Fan assisted
- Automatic evaporator of defrost water
- Ozone friendly
- White interior and black exterior
- Full length internal vertical lights
- Sturdy handle
- Magnetic door gaskets
- Easy access for loading and cleaning
- Easy clean surfaces
- Illuminated canopy for graphics
- Fully adjustable shelves
- Four shelves per door
- Castors supplied with case
- Minimum maintenance
- Low energy consumption
- Double pane glass door(s)
- Self closing door(s)



G4T



G6T

REFRIGERATED

Specifications

Model Numbers

	G4T	G6T
Width (inches)	30	54 ¼
Depth (inches)	28 ¼	28 ¼
Height (inches)	82 ½	82 ½
Canopy dims (inches)	26 ½ w x 5 ½ h	52 w x 5 ½ h
Shelf width x depth (inches)	23 w x 20 ½ d	23 ½ w x 20 d
Number of shelves	4	8
Condensing unit size (HP)	⅓	½
Refrigerant	R134	R134
Power supply v/Hz/Ph (unit)	120/60/1	120/60/1
Amps	20	20
Watts	2000	2000
Temp Range	34/42°F or 1/6°C	34/42°F or 1/6°C

Plug – each unit requires a single dedicated power supply; 24 hour power if keeping product in unit overnight.

K Chillers

REFRIGERATED

K2TF

K2T

Features

- LED lighting
- Anodized gold or silver finish
- Automatic defrost
- Castors supplied with case
- Easy to clean surfaces
- Forced air cooling
- Fully self contained unit
- Glass on four sides
- Heater pan evaporation (no plumbing required)
- Illuminated display
- Rotating glass shelves (K2T) (mirrored bottom shelf)
- Rotation stops when door is opened
- Simple plug in operation



Rotating Shelves



Wire Shelves

*K2TF: adjustable wire shelf version of K2T.
Shelf size (inches) 17 ½ x 17 ½

Specifications

Model Numbers

	K2T	K2TF
Width (inches)	23 ½	23 ½
Depth (inches)	24	24
Height (inches)	71	71
Shelf dimensions (inches)	16 ½ diameter	17 ½ x 17 ½
Number of shelves	6	5
Condensing unit size (HP)	1/3	1/3
Refrigerant	R134	R134
Power supply v/Hz/Ph (unit)	120/60/1	120/60/1
Amps	20	20
Watts	2000	2000
Evaporator fans	1	1
Temp range	35/50°F or 4/10°C	35/50°F or 4/10°C
Plug – each unit requires a single dedicated power supply; 24 hour power if keeping product in unit overnight.		

K3T

Features

- LED lighting
- Anodized gold or silver finish
- Automatic defrost
- Castors supplied with case
- Easy to clean surfaces
- Forced air cooling
- Fully self contained unit
- Glass on six sides (K3T)
- Heater pan evaporation (no plumbing required)
- Illuminated display
- Rotating glass shelves (mirrored bottom shelf)
- Rotation stops when door is opened
- Simple plug in operation



REFRIGERATED

Specifications

Model Number

	K3T
Width (inches)	31 ¾
Depth (inches)	36
Height (inches)	69
Shelf diameter (inches)	22
Number of shelves	5
Condensing unit size (HP)	7/8
Refrigerant	R134
Power supply v/Hz/Ph (unit)	120/60/1
Amps	20
Watts	2000
Evaporator fans	1
Temp range	35/50°F or 4/10°C

Plug – each unit requires a single dedicated power supply; 24 hour power if keeping product in unit overnight.

K2TWR

Features

- Humidity controlled (K2TWCF, K2TWCR)
- Rotating or square glass shelves available
- Beautiful wood finish
- Castors supplied with case
- Economical system
- Glass on all four sides
- All around view of product
- Mirrored bottom shelf
- Adjustable shelves
- Strong construction
- Efficient, quiet system
- Easy to clean surfaces and lines
- Forced air system
- Illuminated display
- Fully self contained unit
- Ozone friendly refrigerant
- Simple plug in operation with simple controls
- Thermostat control
- Operator friendly
- Single door access
- Rotation stops when door is opened



Rotating Shelves

K2TWF



Square Shelves

Specifications

Model Numbers

	K2TWF	K2TWR	K2TWCF	KWTWCR
Application	General	General	Chocolate	Chocolate
Humidity control	No	No	Yes	Yes
Width (inches)	32 ½	32 ½	32 ½	32 ½
Depth (inches)	33 ½	33 ½	33 ½	33 ½
Height (inches)	72	72	72	72
Shelves (square or rotating)	square	Rotating	square	Rotating
Shelf width x depth (inches)	20 ½ w x 22 ½ d	-----	20 ½ w x 22 ½ d	-----
Shelf diameter (inches)	-----	22	-----	22
Number of shelves	5	6	5	6
Condensing unit size (HP)	1/3	1/3	1/3	1/3
Refrigerant	R134	R134	R134	R134
Power supply v/Hz/Ph (unit)	120/60/1	120/60/1	120/60/1	120/60/1
Amps	20	20	20	20
Watts	2000	2000	2000	2000
Evaporator fans	1	1	1	1
Temp Range	35/50°F or 4/10°C	35/50°F or 4/10°C	56/62°F or 14/16°C	56/62°F or 14/16°C

Plug – each unit requires a single dedicated power supply; 24 hour power if keeping product in unit overnight.

H1

Features

- Storage Chiller
- Weighs 73 lbs



G223

Features

- 23 Liter Total Capacity
- 11.5 Liters Per Bowl
- 6.34 Gallon Total Capacity
- 3.17 Gallons Per Bowl
- Motorized paddles maintain mixing of product



Starlet

Features

- Counter top chiller
- Electronic thermostat
- Weighs 85 lbs



Specifications

Model Numbers

	H1	G223	Starlet
Width (inches)	20 ¾	13 ½	24
Depth (inches)	20 ½	17	23
Height (inches)	32 ¼	25	23
Shelf dimensions (inches)	17 w x 13 d	-----	20 ¾ w x 6 ¾ d
Deck dimensions (inches)	17 ½ w x 9 d	-----	20 ¾ w x 6 ½ d
Condensing unit size (HP)	1/6	1/10	1/8
Refrigerant	R134	R134	R134
Power Supply v/Hz/Ph (unit)	120/60/1	120/60/1	120/60/1
Amps	5	15	10
Watts	500	1500	1000
Deck Fans	-----	-----	yes
Temp Range	35/42°F or 2/6°C	39/61°F or 4/16°C	35/42°F or 2/6°C

Plug - each unit requires a single dedicated power supply; 24 hour power if keeping product in unit overnight.

Prep



Features

- Refrigerated Prep Counter
- Stainless steel finish
- Low energy consumption
- Two storage levels
- Adjustable shelves
- Six poly-carbonate inserts included
- Corrosion resistant white interior finish
- Automatic defrost cycle
- Extra deep removable cutting board
- Lockable castors
- Fully mobile

REFRIGERATED

Specifications	Model Number	
	Prep 1	Prep 2
Width (inches)	44 ½	67 ½
Depth (inches)	32 ½	35 ½
Height (inches)	41 ½	41 ½
Storage area (inches)	25 ¼ w x 27 d x 24h	48 w x 27 d x 24 h
Shelf (inches)	24 w x 26 d	23 w x 26 d (x2)
Cutting board dimensions (inches)	44 w x 16 ½ d	67 ½ w x 19 ½ d
Condensing unit size (HP)	1/6	1/2
Refrigerant	R134	R134
Power supply v/Hz/Ph	120/60/1	120/60/1
Amps	20	20
Watts	2000	2000
Fan assisted	yes	yes
Temperature Range	33.8°/41°F	33.8°/41°F

Plug - each unit requires a single dedicated power supply; 24 hour power if keeping product in unit overnight.

B1P

Features

- Top shelf is non-refrigerated
- Top hinged glass, hydraulic arm support
- Easy access for loading, setting of display and cleaning
- Euro style front and side glass
- Illuminated stainless steel, display deck and glass shelves
- Rear access to the display for the server
- Main display deck is accessed via a stainless steel pull out drawer from the rear of the case. Magnetic gaskets ensure a perfect seal
- Three level display
- Preparation counter built in
- Automatic defrost
- No plumbing required, auto evaporation of defrost water
- Easy to clean surfaces and attractive lines
- Castors supplied with case
- Fully self contained unit
- Simple plug in operation
- ABS foamed end walls
- Forced air system



Back View

BAKERY

Specifications

Model Numbers

	B1P
Width (inches)	50 ½
Depth (inches)	43
Height (inches)	51 ½
Top Shelf size (inches)	46 w x 7 ½ d
Bottom Shelf size (inches)	46 w x 10 d
Drawer dimensions (inches)	37 w x 32 ¾ d
Bottom display area total (inches)	47 w x 32 ¾ d
Condensing unit size (HP)	½
Refrigerant	R404
Power supply v/Hz/Ph	120/60/1
Amps	20
Watts	2000
Temp Range	34/42°F or 1/6°C

Plug - each unit requires a single dedicated power supply; 24 hour power if keeping product in unit overnight.

Kubo 500R

Display Refrigerator

Features

- Adjustable wire shelves
- Hinged doors
- Vertical lights
- Castors supplied with case
- 360° visibility
- Easy to clean
- Automatic defrost
- No drain required
- Stainless steel front



BAKERY

Specifications

Model Number

	500R
Width (inches)	60
Depth (inches)	28
Height (inches)	54
Number of shelves	8
Shelf dimensions (inches)	23 1/2 w x 15 3/4 d
Condensing unit size (HP)	1 1/8
Refrigerant	R404
Power supply v/Hz/Ph	120/60/1
Amps	20
Watts	2000
Deck fans	Yes
Temp range	36°/ 50° F or 2°/10° C
Plug - each unit requires a single dedicated power supply; 24 hour power if keeping product in unit overnight.	

Victoria

Features

- Three exhibition levels
- Rear sliding glass doors
- Available in black or stainless finish
- Front access to condensing unit
- Double tempered curved glass
- Castors supplied with case
- Low energy consumption
- Easy to clean
- Automatic defrost cycle
- No drain required
- Stainless steel deck
- Stainless steel front
- Stainless steel shelves
- Static air system
- Wide stainless steel top



BAKERY

Specifications

Model Numbers

	V-150	V-200
Width (inches)	56 2/3	74
Depth (inches)	36	36
Height (inches)	50	50
Number of shelves	4	4
Top shelf dimensions (inches)	24 1/4 w x 15 d	32 7/8 w x 15 d
Other shelf dimensions (inches)	24 1/4 w x 17 d	32 7/8 w x 17 d
Condensing unit size (HP)	1/4	1/3
Refrigerant	R134A	R134A
Power Supply v/Hz/Ph	120/60/1	120/60/1
Amps	20	20
Watts	2000	2000
Temp Range	33/50°F or 2/10°C	33/50°F or 2/10°C

Plug - each unit requires a single dedicated power supply; 24 hour power if keeping product in unit overnight.

L Symphony

Features

- Anodized finish
- Top hinged, curved front glass
- Glass ends
- Fixed glass shelves (3)
- Dual temperature zones
- Top two shelves are non refrigerated
- Stainless steel display deck
- Granite preparation counter built in
- Pull out drawers (stainless steel)
- Magnetic gasket on drawers
- European finish and appearance
- Castors supplied with case
- Economical system
- Static evaporator system
- Strong construction
- Efficient, quiet system
- Easy to clean surfaces and lines
- Illuminated display
- Fully self contained unit
- Ozone friendly refrigerant
- Simple plug in operation with simple controls
- Thermostat control
- Operator friendly
- Sliding door access at rear of case for server



Additional Colors Available

Specifications

Model Numbers

	L1	L3	L5
Width (inches)	55 ¼	87	114 ¼
Depth (inches)	40	40	40
Height (inches)	50	50	50
Number of shelves	3	3	3
Top shelf dimensions (inches)	51 w x 8 ⅔ d	82 ½ w x 8 ⅔ d	110 w x 8 ⅔ d
Middle shelf dimensions (inches)	51 w x 8 ⅔ d	82 ½ w x 8 ⅔ d	110 w x 8 ⅔ d
Lower shelf dimensions (inches)	51 w x 11 d	82 ½ w x 11 d	110 w x 11 d
Number of Drawers	2	3	4
Drawer dimensions (inches)	20 ¾ w x 33 ¾ d	20 ¾ w x 33 ¾ d	20 ¾ w x 33 ¾ d
Condensing unit size (HP)	¼	½	1
Refrigerant	R404	R404	R404
Power supply v/Hz/Ph	120/60/1	120/60/1	120/60/1
Amps	20	20	20
Watts	2000	2000	2000
Static Refrigeration	Yes	Yes	Yes
Temp Range	36/50°F or 2/10°C	36/50°F or 2/10°C	36/50°F or 2/10°C

Plug - each unit requires a single dedicated power supply; 24 hour power if keeping product in unit overnight.

L Harmony

Features

- Anodized finish
- Curved front glass
- Glass ends
- Fixed glass shelves (3)
- Glass all around display
- Stainless steel lower display deck
- Sliding glass doors at rear, full size for access
- European appearance
- Castors supplied with case
- Economical system
- Forced air system- uniform cooling on all levels
- Strong construction
- Efficient, quiet system
- Easy to clean surfaces and lines
- Illuminated display (light above each shelf)
- Fully self contained
- Ozone friendly refrigerant
- Simple plug in operation with simple controls
- Thermostat control
- Operator friendly
- No plumbing required



Additional Colors Available

BAKERY

Specifications

Model Numbers

	L1H	L3H	L5H
Width (inches)	37	52 ½	83
Depth (inches)	31 ¼	31 ¼	31 ¼
Height (inches)	54 ½	54 ½	54 ½
Number of shelves	3	3	3
Top shelf dimensions (inches)	35 ½ w x 13 d	51 w x 13 d	81 ½ w x 13 d
Middle shelf dimensions (inches)	35 ½ w x 13 ½ d	51 w x 13 ½ d	81 ½ w x 13 ½ d
Lower shelf dimensions (inches)	35 ½ w x 16 d	51 w x 16 d	81 ½ w x 16 d
Condensing unit size (HP)	¼	½	1
Refrigerant	R404	R404	R404
Power Supply v/Hz/Ph	120/60/1	120/60/1	120/60/1
Amps	20	20	20
Watts	2000	2000	2000
Fan assisted	Yes	Yes	Yes
Temp Range	34/42°F or 1/6°C	34/42°F or 1/6°C	34/42°F or 1/6°C

Plug - each unit requires a single dedicated power supply; 24 hour power if keeping product in unit overnight.

Bodega

Bod1



Features

- Glass doors
- Interior full length lighting
- Sturdy handle
- Easy to clean interior
- Suitable for refrigerated products
- Efficient, quiet system
- Fully self contained
- Ozone friendly
- Castors supplied with case
- Single temperature or four temperature zones



Bod2

WINE DISPLAY

Specifications

Model Numbers

	Bod1	Bod2
Width (inches)	22 ¾	43
Depth (inches)	25 ½	25 ½
Height (inches)	77 ½	77 ½
Capacity: bottle size – 90	15x4= 60	32x4=128
bottle size – 77	24x4=96	50x4=200
bottle size – 75	24x4=96	52x4=208
Condensing unit size (HP)	1/3	1/2
Refrigerant	R134	R134
Power supply v/Hz/Ph (unit)	120/60/1	120/60/1
Amps	20	20
Watts	2000	2000
Fan assisted	yes	yes
Temp Range	41/60°F or 5/15°C	41/60°F or 5/15°C

Plug – each unit requires a single dedicated power supply; 24 hour power if keeping product in unit overnight.

K1T
4-Sided
Fixed Shelf Freezer

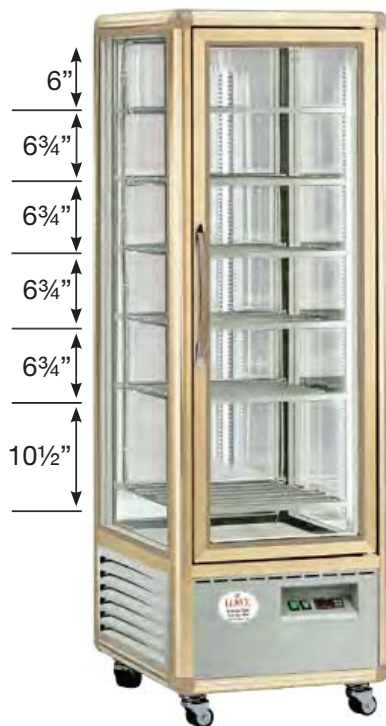

K4TF
4-Sided
Fixed Shelf Freezer



Features

- Anodized Finish
- Glass on all sides
- All around view of product
- Castors supplied with case
- Economical system
- Fixed evaporator shelves
- Efficient, quiet system
- Digital Thermostat control
- No plumbing required

Also Available In Silver

FROZEN

Specifications

Model Numbers

	K1T	K4TF
Width (inches)	23 1/2	28
Depth (inches)	25 1/2	29 1/2
Height (inches)	71 1/4	70
Number of shelves	6	5
Shelf type	Fixed	Fixed
Condensing unit size (HP)	2/3	3/4
Refrigerant	R404	R404
Power Supply v/Hz/Ph	120/60/1	120/60/1
Amps	20	20
Watts	2000	2000
Fixed shelf evaporator	yes	yes
Temp Range	0/-18°C or 32/0°F	0/-18°C or 32/0°F

Plug - each unit requires a single dedicated power supply; 24 hour power if keeping product in unit overnight.

VV17



Features

- Fully adjustable shelves
- 3 shelves standard
- Digital thermostat control
- Vertical lighting
- No plumbing required
- Efficient, quiet system
- Forced air system

Features

- LED lighting
- Anodized finish
- Glass on all sides
- All around view of product
- Castors supplied with case
- Economical system
- Rotating shelves
- Mirrored bottom shelf
- Adjustable shelves
- Efficient, quiet system
- Forced air system
- Digital thermostat control
- No plumbing required
- Gold finish available

K4T

4-Sided
Revolving Shelf Freezer



FROZEN

Specifications	Model Numbers	
	VV17	K4T
Width (inches)	36	28
Depth (inches)	26	29 ½
Height (inches)	60 ½	71 ½
Number of shelves	3	6
Shelf type	Adjustable	Revolving
Shelf Dimensions	30 ½ w x 15 ¾ d	18" Diameter
Condensing unit size (HP)	½	¾
Refrigerant	R404	R404
Power Supply v/Hz/Ph	120/60/1	120/60/1
Amps	20	20
Watts	2000	2000
Fan assisted	yes	yes
Temp Range	0/-18°C or 32/0°F	0/-20°C or 32/-4°F

Plug - each unit requires a single dedicated power supply; 24 hour power if keeping product in unit overnight.

Features

- LED lighting
- Fully adjustable shelves
- Frost free
- Triple pane glass doors
- Self closing doors
- Stainless steel bottom
- No plumbing required, evaporator condensing pan included
- Automatic defrost cycle
- Forced air system
- Illuminated display
- Castors supplied with case



G1T



G6FT

**Improved Visibility
and Lighting**

FROZEN

Specifications

Model Number

	G1T	G6FT
Width (inches)	30	54
Depth (inches)	29 ½	29 ½
Height (inches)	83 ¾	83 ¾
Number of shelves	4	4
Shelf dimensions	23 w x 20 ½ d	23 ½ w x 20 d
Number of doors	1	2
Canopy dims (inches)	26 ½ w x 5 ½ h	52 w x 5 ½ h
Condensing unit size (HP)	½	1
Refrigerant	R404	R404
Power supply v/Hz/Ph (unit)	120/60/1	120/60/1
Amps	20	20
Watts	2000	2000
Fan assisted	Yes	Yes
Temp Range	0/-20°C or 28/-4°F	0/-20°C or 28/-4°F

Plug – each unit requires a single dedicated power supply; 24 hour power if keeping product in unit overnight.

E1 / E2

Display Freezer

Features

- Curved glass front cabinets allow for more product visibility
- 2 sliding glass lids
- Easy access for loading, setting of display and cleaning
- Suitable for all frozen products
- Efficient, quiet system
- Easy to clean surfaces and attractive lines
- Fully self contained unit
- Ozone friendly refrigerant
- Simple plug in operation with simple controls
- Castors supplied with case



FROZEN

Specifications	Model Number	
	E1	E2
Width (inches)	60	88
Depth (inches)	35 ½	35 ½
Height (inches)	40	40
Condensing unit size (HP)	½	½
Refrigerant	R404	R404
Power Supply v/Hz/Ph	120/60/1	120/60/1
Amps	20	20
Watts	2000	2000
Static Refrigeration	Yes	Yes
Temp Range	0/-22°C or 32/-8°F	0/-22°C or 32/-8°F

Plug - each unit requires a single dedicated power supply; 24 hour power if keeping product in unit overnight.

E3

Display Freezer

Features

- Curved glass front cabinets allow for more product visibility
- 2 sliding glass lids
- Easy access for loading, setting of display and cleaning
- Suitable for all frozen products
- Efficient, quiet system
- Easy to clean surfaces and attractive lines
- Fully self contained unit
- Ozone friendly refrigerant
- Simple plug in operation with simple controls
- Castors supplied with case



FROZEN

Specifications

Model Number

	E3
Width (inches)	77
Depth (inches)	34
Height (inches)	37
Condensing unit size (HP)	1/2
Refrigerant	R404
Power Supply v/Hz/Ph	120/60/1
Amps	20
Watts	2000
Static Refrigeration	Yes
Temp Range	0/-22°C or 32/-8°F

Plug - each unit requires a single dedicated power supply; 24 hour power if keeping product in unit overnight.

E4

Display Freezer

Features

- Glass front cabinets allow for more product visibility
- 2 sliding glass lids
- Easy access for loading, setting of display and cleaning
- Suitable for all frozen products
- Efficient, quiet system
- Easy to clean surfaces and attractive lines
- Fully self contained unit
- Ozone friendly refrigerant
- Simple plug in operation with simple controls
- Castors supplied with case



Specifications

Model Number

	E4
Width (inches)	77
Depth (inches)	34
Height (inches)	39
Condensing unit size (HP)	½
Refrigerant	R404
Power supply v/Hz/Ph	120/60/1
Amps	20
Watts	2000
Static refrigeration	Yes
Temp range	0/-22°C or 32/-8°F

Plug - each unit requires a single dedicated power supply; 24 hour power if keeping product in unit overnight.

D1C

Display Freezer

Features

- 5 baskets standard
- 2 sliding glass lids
- LED lighting
- Easy access for loading, setting of display and cleaning
- Suitable for all frozen products
- Efficient, quiet system
- Easy to clean surfaces and attractive lines
- Fully self contained unit
- Simple plug in operation with simple controls
- Castors supplied with case



FROZEN

Specifications

Model Number

	D1C
Width (inches)	58
Depth (inches)	30
Height (inches)	34
Condensing unit size (HP)	1/2
Refrigerant	R134A
Power supply v/Hz/Ph	120/60/1
Amps	20
Watts	2000
Static refrigeration	Yes
Temp range	0/-20°C or 50/-4°F

Plug - each unit requires a single dedicated power supply; 24 hour power if keeping product in unit overnight.

Kubo 500F

Display Freezer

Features

- Adjustable wire shelves
- Hinged doors
- Vertical lights
- Castors supplied with case
- 360° visibility
- Easy to clean
- Automatic defrost
- No drain required
- Stainless steel front



FROZEN

Specifications

Model Number

500F

Width (inches)	60
Depth (inches)	28
Height (inches)	54
Number of shelves	8
Shelf dimensions (inches)	23 ½ w x 15 ¾ d
Condensing unit size (HP)	1 ⅛
Refrigerant	R404
Power supply v/Hz/Ph	120/60/1
Amps	20
Watts	2000
Deck fans	Yes
Temp range	0/-18°C or 32/0°F

Plug - each unit requires a single dedicated power supply; 24 hour power if keeping product in unit overnight.

B2F
Display Freezer



Limited Quantity Available

Features

- Top hinged glass, hydraulic arm support
- Easy access for loading, setting of display and cleaning
- Euro style front and side glass
- Stainless steel interior
- Rear access to the display for the server
- Preparation counter built in
- Easy to clean surfaces and attractive lines
- Castors supplied with case
- Fully self contained unit
- Simple plug in operation with simple controls
- Impact resistant finish
- ABS foamed end walls

***Note: No Refrigerated Understorage.**

FROZEN

Specifications	Model Number
	B2F
Width (inches)	73 ½
Depth (inches)	43
Height (inches)	51 ½
Condensing unit size (HP)	1
Refrigerant	R404
Power supply v/Hz/Ph	120/60/1
Amp	20
Watts	2000
Deck fans	Yes
Temp range	0/-18°C or 32/0°F

Plug - each unit requires a single dedicated power supply; 24 hour power if keeping product in unit overnight.

F2



Features

- 2 sliding glass lids
- Easy access for loading, setting of display and cleaning
- Excellent vision through top glass
- White interior and exterior
- Suitable for all frozen products
- Efficient, quiet system
- Easy to clean surfaces and attractive lines
- Fully self contained unit
- Ozone friendly refrigerant
- Simple plug in operation with simple controls
- Manual defrost and drain
- One standard basket included
- Impact resistant finish
- Castors supplied with case

Specifications

Model Number

	F2
Width (inches)	47 ¼
Depth (inches)	24 ¾
Height (inches)	34 ¼
Inside width (inches)	42
Inside depth (inches)	20
Inside height (inches)	25
Storage capacity (cubic feet)	12 ¼
Condensing unit size (HP)	¾
Refrigerant	R404
Power supply v/Hz/Ph	120/60/1
Amps	20
Watts	2000
Deck fans	n/a
Temp range	0/-20°C or 32/-4°F

Plug - each unit requires a single dedicated power supply; 24 hour power if keeping product in unit overnight.

DC8 Dipping Cabinet

Features

- Modern design with high visibility
- Stainless steel preparation counter
- Stainless steel deck
- Silver painted end walls
- Sliding plexi rear doors
- Illuminated logo panel
- Internal lighting for product
- Pricing rails
- Castors supplied with case
- No drain required
- Automatic defrost
- 8 and 12 flavor cabinet available
- Holds 2 ½ gallon size tubs (10 inch deep x 10 diameter)



FROZEN

Specifications

Model Numbers

	DC8	DC12
Width (inches)	50 ¼	72
Depth (inches)	43 ½	43 ½
Height (inches)	56	56
Condensing unit size (HP)	¾ x 2	¾ x 2
Refrigerant	R404	R404
Power supply v/Hz/Ph	120/60/1	120/60/1
Amps	30	30
Watts	3000	3000
Deck fans	Yes	Yes
Temp range	3/-4°F or -16/-20°C	3/-4°F or -16/-20°C

Plug - each unit requires a single dedicated power supply; 24 hour power if keeping product in unit overnight.

G12

Gelato-Italian Ice Cream



Features

- Modern design – high visibility
- Painted gray ABS end walls
- Stainless steel preparation counter
- Fully mobile
- Castors supplied with case
- Stainless steel bins
- Stainless steel front
- Sliding rear doors
- Full length illumination of product
- Pricing rails
- Illumination panel for product transparencies

FROZEN

Specifications	Model Number
	G12
Width (inches)	50 ¼
Depth (inches)	44 ¾
Height (inches)	54 ¾
Condensing unit size (HP)	¾
Refrigerant	R404
Power supply v/Hz/Ph	220v single phase
Amps	30
Watts	3000
Deck fans	Yes
Temp range	0/-18°C or 03/0°F

Plug - each unit requires a single dedicated power supply; 24 hour power if keeping product in unit overnight.

SS2P

Two Flavor Soft Serve Ice Cream Machine

Features

- Small foot print, saves valuable floor space
- Easy cleaning and operation
- No installation required, plug it in and it is ready to go
- Castors supplied with case
- Soft serve mix not included
- Sanitized prior to each rental
- Serves two flavors plus a swirl option.
- Overnight switch to keep product refrigerated when not in use
- Automatic shut off when product is low



FROZEN

Specifications

Model Number

	SS2P
Width (inches)	21
Depth (inches)	27 ½
Height (inches)	52
Condensing unit size (HP)	1 ⅛, ⅛
Refrigerant	R404
Power supply v/Hz/Ph	220V single phase
Amps	30
Watts	3000

Plug - each unit requires a single dedicated power supply; 24 hour power if keeping product in unit overnight.

200 GBT

Fixed Shelves



Features

- Gold or silver anodized finish
- Glass walls
- Smooth finish. Rounded corners
- Static evaporator system
- Rapid pull down time
- Strong construction
- Efficient, quiet system
- Easy to clean surface and lines
- Illuminated display
- Fully self contained unit
- Ozone friendly refrigerant
- Simple plug in operation with simple controls
- Operator friendly
- Thermostat control
- Fixed shelves are 7 ¼ inches apart

H4IB

Storage Freezer



Features

- Adjustable shelves
- Glass display
- Counter top unit
- Efficient, quiet system

Specifications

Model Numbers

	200 GBT	H4IB
Width (inches)	47 ½	23 ½
Depth (inches)	19 ½	20 ¼
Height (inches)	28	26 ½
Condensing unit size (HP)	1/3	1/4
Refrigerant	R404	R134
Power supply v/Hz/Ph	120/60/1	120/60/1
Amps	20	20
Watts	2000	2000
Fan assisted	no	yes
Temp range	0/-18°C or 32/0°F	0/-18°C or 32/0°F
Fixed shelf evaporator	yes	no

Plug - each unit requires a single dedicated power supply; 24 hour power if keeping product in unit overnight.



Penguin 1
*Single Bowl
Frozen Drink Display*

Penguin 2
*Double Bowl
Frozen Drink Display*



Features

- One or two bowl frozen drink display
- Full access to all the components for quick and easy maintenance
- Simple bowl removal for easy cleaning
- One compressor for each bowl
- Manual control of the thickness of the drink
- Quick product preparation
- Internal illumination system

H2



Features

- Efficient, quiet system
- Perfect for under counter use

FROZEN

Specifications	Model Numbers		
	H2	Penguin 1	Penguin 2
Width (inches)	19 ½	7 ¾	15 ⅓
Depth (inches)	21 ½	17	17
Height (inches)	32 ¾	34 ¼	34 ¼
Bowl capacity in liters	n/a	12	12
Bowl capacity in gallons	n/a	3.17	3.17
Condensing unit size (HP)	¼	¼	½
Refrigerant	R134	R134	R134
Power supply v/Hz/Ph	120/60/1	120/60/1	120/60/1
Amps	20	20	20
Watts	2000	2000	2000
Temp range	0/-18°C or 32/0°F	frozen drinks	frozen drinks

Plug - each unit requires a single dedicated power supply; 24 hour power if keeping product in unit overnight.

Isola 4H

Features

- Electrically raised canopy
- Castors supplied with case
- Divider bars included
- Stainless steel option available
- Adjustable water temperature control
- Fitted drain
- Heat lamps for additional heating
- 'Low water level' alarm
- Serving trays optional
- Digital control panel
- Pans available upon request
- Internal basin in AISI stainless steel
- Accepts deep or shallow pans
- Different configurations available
- Gastronorm pans available upon request



Isola 4H

Lid Electronically Lowered.

Specifications

Model Numbers

	Isola 4H	Isola 4HS/S
Width (inches)	56	59 ¼
Depth (inches)	29½	29 ½
Height (inches) top down	45 ¼	45
Height (inches) top up	59	59
Power supply v/Hz/Ph	120/60/1	120/60/1
Amps	30	30
Watts	3000	3000
Temp range	100/194°F or 38/90°C	100/194°F or 38/90°C

Plug - each unit requires a single dedicated power supply.

HOT

B1H

Features

- Top hinged glass, hydraulic arm support
- Easy access for loading, setting of display and cleaning
- Euro style front and side glass
- Illuminated stainless steel, perforated display deck
- Rear access to the display for the server
- Preparation counter built in
- Automatic 'low water level' power cut-off
- Easy to clean surfaces and attractive lines
- Castors supplied with case
- Fully self contained unit
- Rheostat control for heat/light
- Simple plug in operation with simple controls
- Adjustable water temperature control
- Water inlet (1/2 inch) and drain fitting (1 1/2 inch)
- Impact resistant finish
- Stainless steel deck
- ABS foamed end walls
- Divider bars for Gastronorm pans available
- Heating area can be configured several ways using divider bars.
- Heating area dimensions: 42 x 25 1/2 (inches)
- Gastronorm pans available upon request



HOT

Specifications

Model Number

	B1H
Width (inches)	51
Depth (inches)	43
Height (inches)	51 1/2
Power Supply v/Hz/Ph	220/60/1
Amps	30
Watts	3000
Water Temperature Range	167/176°F or 75/80°C
Deck Temperature	146°F or 63°C

Plug - each unit requires a single dedicated power supply.

BR13H

Features

- 4 Adjustable heated shelves
- Sliding glass rear doors
- Vertical lights
- Castors supplied with case
- No drain required
- Modern design
- 360° visibility
- Stainless steel front
- Stainless steel front
- Easy to clean



HOT

Specifications

Model Number

BR13H

Width (inches)	53
Depth (inches)	29 ½
Height (inches)	54 ¼
Top shelf dimensions (inches)	50 w x 11 d
Other shelf dimensions (inches)	50 w x 11 d
Power Supply v/Hz/Ph	120/60/1
Amps	30
Watts	3000
Temperature Range	140/176°F or 60/80°C

Plug - each unit requires a single dedicated power supply.

MCT
4 Burner



Features

- Stainless steel table with electric 4 burner ceramic cook top
- Locking castors included
- Under cabinet storage shelf
- Optional attached mirror for high visibility



MCT
Back View - Under Storage



MCTM
With Mirror

HOT

Specifications

Model Numbers

	MCT	MCTM
Width (inches)	60	60
Depth (inches)	30 ¼	30 ¼
Height (inches)	36	97
Power Supply v/Hz/Ph	220/60/1	220/60/1
Amps	30	30
Watts	3000	3000

Plug - each unit requires a single dedicated power supply.

CO25 Convection Oven

Features

- Convection oven with two adjustable shelves
- Holds ½ size tray: 18 x 14 ½ (inches) - not included
- Trays for oven available upon request
- Oven is attached to rolling stand
- Oven available without stand
- Rolling stand has six shelves for sheet pans
- Sheet pans for stand available upon request
- Manual 60 minute timer

Specifications

Model Number

CO25

Width (inches)	28 ½
Depth (inches)	28
Height (inches)	53 ¾
Inside width (inches)	18 ½
Inside depth (inches)	14 ½
Inside height (inches)	10 5/8
Power Supply v/Hz/Ph	120/60/1
Amps	20
Watts	2000
Temperature Range	120/480°F or 49/249°C

Plug - each unit requires a single dedicated power supply.



MW Microwave



Specifications

Model Number

MW

Width (inches)	24
Depth (inches)	18
Height (inches)	14
Power Supply v/Hz/Ph	120/60/1
Amps	10
Watts	1000

Plug - each unit requires a single dedicated power supply.

Top2

Dual burner cook top



Features

- 2 electric burners
- Compact and lightweight



DW

Dual lamp display warmer

Features

- Holds a 12 x 20 (inches) Pan
- Pan not included

Specifications

Model Numbers

	Top2	DW
Width (inches)	22 ½	13
Depth (inches)	14	19
Height (inches)	3	24 ¼
Power Supply v/Hz/Ph	120/60/1	120/60/1
Amps	20	20
Watts	2000	2000

Plug - each unit requires a single dedicated power supply.

200 Hot

(Self Serve) Counter Top



Features

- Warming lamps above each shelf
- Sturdy construction designed for easy access of product
- Self serve open access

Specifications

Model Number

200 Hot

Width (inches)	35 ½
Depth (inches)	21
Height (inches)	28
Power Supply v/Hz/Ph	120/60/1
Amps	15
Watts	1500
Temperature Range	95/160°F or 35/71°C

Plug - each unit requires a single dedicated power supply.

HOT

HSD2



Features

- Hard coated aluminum heat shelf
- Tempered glass sides for maximum visibility
- Heavy duty stainless steel construction for base, sides and top
- Thermostat controlled heat for base and rear overhead heat source.

Specifications

Model Number

HSD2

Width (inches)	36
Depth (inches)	28
Height (inches)	29 ¾
Power Supply v/Hz/Ph	120/60/1
Amps	20
Watts	2000

Plug - each unit requires a single dedicated power supply.



I1 / I3
Display Ice Tray

MS12
Electric Meat Slicer
12" Cutting Wheel



200 Dry
Self-Serve Counter Top Display

- Gold or silver anodized finish
- Easy to clean surfaces and lines
- Glass walls
- Multi purpose
- Illuminated display
- Smooth finish
- Rounded corners
- Strong construction
- Simple plug In operation with simple controls

NON REFRIGERATED

Specifications	Model Numbers			
	I1	I3	MS12	200 Dry
Width (inches)	40	64	23	35 ¼
Depth (inches)	22	22	18	21
Height (inches)	7	7	16	28
Power Supply v/Hz/Ph	n/a	n/a	120/60/1	120/60/1
Amps	n/a	n/a	15	5
Watts	n/a	n/a	1500	500

Plug - each unit requires a single dedicated power supply.

MSU

*Mobile Sink Unit
For Hands and Utensils Only*



Features

- Hand sink cart with 2-compartment sink
- Two 5 gallon water tanks
- Two 7 gallon waste water tanks
- 2½ gallon hot water heater
- Soap dispenser and paper towel holder included
- Durable polyethylene construction
- Castors supplied with case

Specifications

Model Number

MSU

Width (inches)	41
Depth (inches)	32 ½
Height (inches)	45 ½
Power Supply v/Hz/Ph	120/60/1
Amps	15
Watts	1500
Fresh water capacity	2 x 5 gallon or 18.92 liters
Waste tank capacity	2 x 7 gallon or 26.49 liters
Plug - each unit requires a single dedicated power supply.	

NON REFRIGERATED

HWS

Two Person Accessible Hand Washing Station



Features

- 1,408 single uses (22-gallon fresh water capacity; 24-gallon gray water capacity)
- Two 30-ounce soap dispensers and four 250-sheet built-in paper towel dispensers
- Fits inside most portable restrooms for easy transport to job sites
- Built-in lift handles provide added mobility for positioning once on-site.

Specifications

Model Number

HWS

Width (inches)	26 ½
Depth (inches)	21 ½
Height (inches)	61
Fresh water capacity	22 gallon or 83.28 liters
Waste tank capacity	24 gallon or 90.85 liters

PTS

Stainless Steel Prep Table with Shelf



Features

- Stainless steel work surface
- Model with shelf available

PT

Stainless Steel Prep Table



NON REFRIGERATED

Specifications

Model Numbers

	PT4 / PT4S	PT5 / PT5S	PT6 / PT6S
Width (inches)	48	60	72
Depth (inches)	30	30	30
Height (inches)	35	35	35

Sinks

SSB1



Features

- Stainless steel bowl sink
- Plumbing required
- Single bowl and three bowl sinks available
- Water inlet (1 inch) and drain fitting (1 3/4 inch)

SSB3



Specifications

Model Numbers

	SSB1	SSB3
Width (inches)	23 1/2	84
Depth (inches)	24 1/2	24 1/2
Height (inches)	40	40

NON REFRIGERATED

Ready Built Cold Rooms

Features

- “All-Weather” exterior
- Internal light
- Internal “glow in the dark” safety handle
- Easily made mobile
- Refrigerator & freezer temps available
- NSF approved “3-tier” racking included
- Secure, simple temperature control
- Non-slip floor
- Ramp included
- Fork lift friendly
- Lockable door - self closing!
- Strong hinge system
- External gauge displaying box temperature
- Quiet operation of ETL approved condensing unit
- Health and safety code compliant
- Simply hardwire to your generator or existing power!



COLD ROOMS

Specifications

External Width (inches)	94 ¼
External Length (inches)	117 ¾
External Height (inches)	93
Power Supply v/Hz/Ph	220/60/1
Amps	30

Modular walk-in cold and freezer rooms.



From the world's largest sporting events to state fairs, festivals, care centers, emergency relief, construction renovation, and so much more, LOWE Cold Rooms provide the perfect refrigerated storage solution.

Mobile & remote, climate controlled modular refrigeration / freezer cold rooms engineered for quiet efficiency even in the most challenging environments.

8ft by 8ft Modular Walk-in Cold Room. (smallest size available)
Length can be increased in 2ft increments.
Width can be increased in 8ft increments with interior walls.



Quickly built on-site • Dual temperature • Indoor and outdoor use • Pallet size doors available.

With the largest modular cold room rental fleet in the world, LOWE Refrigeration's extensive logistical program enables us to meet your unique event requirements and ensure successful on time delivery and installation to your event.

Take advantage of our freight savings!

A large number of modular cold rooms can be loaded onto a single trailer.

This creates an efficiency and economy that ready built rooms can't duplicate.



Our steel frame leveling system allows us to place cold rooms almost anywhere, and create efficiency by placing refrigerated storage in convenient locations.



Our quick & efficient on-site build process saves you time and money.



Tie Down Straps can be placed over modular cold rooms to provide extra security in high wind environments. Strapping uses a ratchet and stake system that allows each unit to be pinned in place. This system includes ratchets, pin stakes, stake puller, mid and end straps.

Cold Storage – Where you need it. When you need it.



Build on pristine grass in front of clubhouse.
No forklift needed.



Inside or outside of any structure.
No fumes. Almost silent!



No vehicular access - no problem. Modular cold rooms can be taken through 3ft door to build inside.



Build on a cart path or remote site with ease!

COLD ROOMS

Specifications

Power Requirements	220v / 60Hz / Single Phase / 30 Amp Breaker (Note: LOWE can supply a splitter box allowing 2 motors to run off a single power supply.)	
Drain	Not Required	
Inside Door Handle	Glow in the dark	
Strip Curtain	Fitted at door entry	
Color	White	
Dimensions	Internal	External
Width (inches)	88	95
Height (inches)	80	87
Length (inches)	88	95
8ft x 8ft is the smallest size available. Length increases by increments of 2ft. Width increases by increments of 8ft with interior walls.		
Call to reserve your customized cold room!		

LOWE Modular Cold Room Features & Benefits

LOWE can support events anywhere in North America with modular cold rooms suitable for indoor and outdoor use.

Our modular cold rooms offer a clean, safe and quiet refrigeration/frozen storage option in almost any environment.

- uneven or sloping ground
- on a cart path
- on the beach
- on dirt, grass, gravel or asphalt
- on a platform
- under a bridge
- inside a building
- inside a room
- on a rooftop
- at limited access or remote locations

Chefs and Concessions enjoy having their refrigerated storage when they need it – right next to them!

Our modular cold rooms are also available for beer cooler configuration, a climate controlled preparation, storage room or office.

(Note: Our offices in Europe and Asia provide a similar service.)



Cold Room used for keg storage.



Contact

USA

105 CECIL COURT
FAYETTEVILLE, GEORGIA
30214
1 770 461 9001
1 844 655 1320

HEAD OFFICE

UNIT J, KNOCKMORE
INDUSTRIAL ESTATE,
MOIRA ROAD,
LISBURN
NORTHERN IRELAND
BT28 2EJ
+44 (0) 28 9260 4619

ENGLAND

LOWE RENTAL LTD.
UNIT 37, MARCHINGTON INDUSTRIAL
ESTATE
UTTOXETER, STAFFORDSHIRE
ENGLAND
ST14 8LP
+44 (0) 1283 820 717

SCOTLAND

LOWE RENTAL LTD.
UNIT 1B EXCELSIOR PARK
CANYON ROAD
NETHERTON INDUSTRIAL ESTATE
WISHAW
SCOTLAND
ML2 0EG
44 (0) 16983 72902

DUBAI

DIP 1. BUILDING WO NO.8
DUBAI, UAE
(+971) 4 882 9440

SINGAPORE

7 KAKI BUKIT CRESCENT,
FULLION BUILDING,
#01-01 SINGAPORE 416239.
+65 6284 1552

HONG KONG

LOWE REFRIGERATION LTD.
RM. 11, 14/F, WAH WAI CENTRE,
38-40 AU PUI WAN STREET,
FO TAN, N.T.
HONG KONG
+65 6284 1552

GERMANY

LOWE DEUTSCHLAND GMBH.
HOHLSTUCK 4
56368 KLINGELBACH
GERMANY
+49 (0) 6486 9039 68

ITALY

LOWE ITALIA SRL.
MILANO
ITALY
+39 023 6000 121

SPAIN

LOWE RENTAL LTD.
BARCELONA
SPAIN
+34 9 3800 1963





September 13-15, 2018
 Baltimore Convention Center
 Baltimore, MD
 Order Closing Date: August 20th, 2018

REMIT TO:
Lowe Refrigeration, Inc.
 105 Cecil Court
 Fayetteville, GA 30214
 USA
 Tel: (770) 461-9001
 Fax: (770) 461-8020
 Email: info@LoweUSA.com
 www.LoweUSA.com

NAME OF EXHIBITOR			BOOTH #	
ADDRESS				
CITY		STATE	ZIP	COUNTRY
PHONE #			FAX #	
ORDER CONTACT NAME			EMAIL ADDRESS	

NOTE: 8% Damage Waiver Applied to ALL Orders

*NO REFUNDS FOR CANCELLATION AFTER CLOSING DATE

**R
E
F
R
I
G
E
R
A
T
E
D**

MODEL	SIZE & DESCRIPTION	QTY	RENTAL \$	TOTAL \$
B CORNER	90 Degree Corner Euro Deli Display		1850	
B1	4ft Euro Deli Curved Glass Display With Refrigerated Under Storage		1850	
B2	6ft Euro Deli Curved Glass Display With Refrigerated Under Storage		2050	
B3	8ft Euro Deli Curved Glass Display With Refrigerated Under Storage		2350	
B1 L/G	4ft Euro Deli Self-Service Display With Refrigerated Under Storage		1850	
B2 L/G	6ft Euro Deli Self-Service Display With Refrigerated Under Storage		2050	
B3 L/G	8ft Euro Deli Self-Service Display With Refrigerated Under Storage		2350	
B1P	4ft Euro Bakery Curved Glass Display With Pull-Out Drawer		1850	
BOD1	23" Glass Door Wine Display - Holds 96 Size 75 Bottles		1260	
BOD2	43" Double Glass Door Wine Display - Holds 208 Size 75 Bottles		1850	
C1	3.5ft Euro Merchandiser 4 Shelf Display (extra shelves \$20each /Qty _____)		1750	
C2	4ft Euro Merchandiser 4 Shelf Display (extra shelves \$25each /Qty _____)		1850	
C3	6ft Euro Merchandiser 4 Shelf Display (extra shelves \$30each /Qty _____)		2050	
F2 CHILLER	64" Sliding Lid Refrigerator		700	
G4T	30" Single Glass Door Refrigerator		900	
G6T	54" Double Glass Door Refrigerator		1575	
G223	2 Bowl Drink Dispenser (23 Liters / 6.3 Gallons Total Capacity)		600	
GENOVA 1	42" Refrigerated Open Front Merchandiser		1750	
GENOVA 2	54" Refrigerated Open Front Merchandiser		1850	
H1	4 cu-ft Storage Refrigerator		250	
ISOLA 4	56" Cold Buffet Style Display (Stainless Steel Available Upon Request)		1650	
ISOLA 6	81" Cold Buffet Style Display (Stainless Steel Available Upon Request)		1850	
JINNY 104	3ft Slim-Line Deli Curved Glass Display With Refrigerated Under Storage		1575	
JINNY 150	5ft Slim-Line Deli Curved Glass Display With Refrigerated Under Storage		1800	
JINNY 250	8ft Slim-Line Deli Curved Glass Display With Refrigerated Under Storage		2300	
K2T	4 Sided Glass Display With 16.5" Rotating Shelves		1700	
K2TF	4 Sided Glass Display With Wire Shelves		1700	
K2TWR	4 Sided Glass Display With Wood Finish & 22" Rotating Shelves		1700	
K2TWF	4 Sided Glass Display With Wood Finish & Fixed Shelves		1700	
K2TWCR	4 Sided Glass CANDY Display With Wood Finish & 22" Rotating Shelves		1700	
K2TWCF	4 Sided Glass CANDY Display With Wood Finish & Fixed Shelves		1700	
K3T	6 Sided Glass Display With 22" Rotating Shelves		1750	
KUBO 500R	60" Double Glass Door Display Refrigerator		1750	
L1	55" Euro Bakery Display With Dual Temperature Zones & Pull Out Drawer		1650	
L3	87" Euro Bakery Display With Dual Temperature Zones & Pull Out Drawer		2000	
L5	114" Euro Bakery Display With Dual Temperature Zones & Pull Out Drawer		2250	
L1HARMONY	37" Euro Bakery Display With 3 Fixed Shelves & Lighting On Each Shelf		1650	
L3HARMONY	52.5" Euro Bakery Display With 3 Fixed Shelves & Lighting On Each Shelf		1850	
MANDY 100	40" Open Front Merchandiser 3 Adjustable Shelf Display		1575	
MEMPHIS 90	36" Dual Temperature Zone Merchandiser Display		1650	
MEMPHIS 120	48" Dual Temperature Zone Merchandiser Display		1750	
OASIS 1	43" Square Island Display With Wood Finish & Suitable For Ice		1750	
OASIS 2	55" Square Island Display With Wood Finish & Suitable For Ice		1950	
P360	55" Grab & Go Island Display		1850	
PREP 1	41.5" Stainless Steel Refrigerated Prep Counter		900	
PREP 2	67.5" Stainless Steel Refrigerated Prep Counter		1325	
SARA	4ft Open Front Merchandiser 3 Adjustable Shelf Display		1700	
STARLET	24" Counter Top Refrigerator		450	
V-150	56" Curved Glass Bakery Display With Adjustable Shelves		1500	
V-200	74" Curved Glass Bakery Display With Adjustable Shelves		1950	

PAGE 1 SUBTOTAL

OFFICE USE ONLY IC BB O#

REV 11/13

PAGE 1 OF 2



September 13-15, 2018
 Baltimore Convention Center
 Baltimore, MD

Order Closing Date: August 20th, 2018

REMIT TO:
Lowe Refrigeration, Inc.
 105 Cecil Court
 Fayetteville, GA 30214
 USA
 Tel: (770) 461-9001
 Fax: (770) 461-8020
 Email: info@LoweUSA.com
 www.LoweUSA.com

PRODUCT INSURANCE IS THE RESPONSIBILITY OF THE EXHIBITOR. CHARGES INCLUDE DELIVERY, INSTALLATION, COLLECTION, AND MAINTENANCE DURING THE

SPECIAL REQUEST:

PAYMENT IS REQUIRED PRIOR TO CLOSING DATE. EQUIPMENT WILL NOT BE INSTALLED UNLESS PAYMENT HAS BEEN RECEIVED. ADDITIONAL 10% WILL BE APPLIED TO ALL ORDERS RECEIVED AFTER THE CLOSING DATE.

NOTE: 8% Damage Waiver Applied to ALL Orders

*NO REFUNDS FOR CANCELLATION AFTER CLOSING DATE

	MODEL	SIZE & DESCRIPTION	QTY	RENTAL \$	TOTAL \$
H O T	200H	35.5" Counter Top Hot Self-Service Display		630	
	B1H	4ft Euro Hot Curved Glass Display With Steam Deck (Bars with Pans by Req		1850	
	BR13H	53" Curved Glass Hot Display With 3 Adjustable Shelves		1850	
	CO25	Convection Oven With Stand - Fits 1/2 Size Trays		700	
	DW	13" 2 Lamp Display Warmer (Pan by Request)		125	
	HSD2	36" Aluminum Heat Shelf		700	
	ISOLA 4H	56" Hot Bain Marie Buffet Style Display		1850	
	MCT	60" Mobile 4 Burner Cook Top		800	
	MCT-M	60" Mobile 4 Burner Cook Top With Display Mirror		825	
	MW	Microwave		250	
	TOP2	23" Counter Top Dual Burner Cook Top		150	
F R O Z E N	200GBT	48" Counter Top Display Freezer		650	
	B2F	6ft Euro Curved Glass Display Freezer		2050	
	D1C	58" Wall Site Display Freezer With 5 Baskets		1500	
	DC8	8 Well Ice Cream Dipping Cabinet		1575	
	DC12	12 Well Ice Cream Dipping Cabinet		2350	
	E1	5ft Wall Site Display Freezer		1700	
	E2	7ft Wall Site Display Freezer		1900	
	E3	6ft Wall Site Display Freezer with Side Visibility		1900	
	E4	6ft Wall Site Display Freezer		1900	
	F2	47" Sliding Glass Top Freezer With 1 Basket		700	
	G1T	30" Single Glass Door Freezer		1325	
	G6FT	54" Double Glass Door Freezer		1750	
	G12	54" Gelato Ice Cream Cabinet		2050	
	H2	4 cu-ft Storage Freezer		300	
	H4IB	24" Counter Top Display Freezer		500	
	K1T	24" 4 Sided Glass Display Freezer With Fixed Shelves		1700	
	K4T	27.5" 4 Sided Glass Display Freezer With 18" Rotating Shelves		1700	
	K4TF	27.5" 4 Sided Glass Display Freezer With Fixed Shelves		1700	
	KUBO 500F	60" Double Glass Door Display Freezer		1900	
	PENGUIN 1	Single Bowl Frozen Drink Display		450	
PENGUIN 2	Double Bowl Frozen Drink Display		600		
VV17	60.5" Double Glass Door Freezer		1850		
SS2P	52" Two Flavor Soft Serve Ice Cream Machine		1850		
D R Y	200DRY	35" Counter Top Dry Display		450	
	HWS	2 Person Hand Washing Station		450	
	I1	40" Insulated Ice Tray With Drain Plug		275	
	I3	64" Insulated Ice Tray With Drain Plug		300	
	MS12	23" Electric Meat Slicer		525	
	MSU	39.5" Mobile Hand Washing Sink		525	
	PT4	4ft Stainless-Steel Prep Table (Add Bottom Shelf \$50.00 check here)		160	
	PT5	5ft Stainless-Steel Prep Table (Add Bottom Shelf \$50.00 check here)		185	
	PT6	6ft Stainless-Steel Prep Table (Add Bottom Shelf \$50.00 check here)		225	
	SSB1	23.5" Stainless-Steel Single-Bowl Sink (PLUMBING REQUIRED)		250	
SSB3	83" Stainless-Steel Three-Bowl Sink (PLUMBING REQUIRED)		370		

PAYMENT TYPE: CHECK BANK WIRE VISA MASTERCARD DINER'S CLUB AMEX

CREDIT CARD #	EXP. DATE
NAME ON CARD	SECURITY CODE

SIGNING BELOW COMPLETES YOUR ORDER AND IS ACCEPTANCE OF OUR RENTAL TERMS & CONDITIONS AVAILABLE FROM THE ABOVE OFFICE OR www.LoweUSA.com

PAGE 1 CONTACT NAME SIGNATURE

OFFICE USE ONLY | IC | BB | O# | INV#

PAGE 2 SUBTOTAL	
PAGE 1 SUBTOTAL	
MISC.	
EQUIPMENT TOTAL	
Damage Waiver 8%	
TOTAL	
RENTAL TAX 6%	
GRAND TOTAL US \$	



CONVENTION PLANNING SERVICES

Registration Personnel

Visit Baltimore maintains and operates an internal staff of convention registration personnel, trained to fulfill the on-site registration needs of conventions and groups at the Baltimore Convention Center or area hotels. This team is available to handle multiple tasks including data entry, room monitoring, registration, information, cashiering, labor and more.

To ensure that your staffing requirements are met, a written request and schedule of your needs is required at least 45 days in advance of the first day of your meeting. Please see below for current rates and general job descriptions. You may contact us at 410-659-7069 or aperry@baltimore.org.

Registration Rates (Four-hour minimum)

Registrar Personnel

Registrar Personnel – Regular Time (8 hours or less in a day)	\$18.00 per hour
Registrar Personnel – Overtime (any time worked past 8 hours in one day)	\$25.00 per hour

* Due to larger or overlapping groups, Visit Baltimore may utilize approved temporary staffing agencies to assist with personnel needs and requirements. These rates are consistent with the rates listed above.

Supervisors

Supervisor – Regular Time	\$22.00 per hour
Supervisor – Overtime (any time worked past 8 hours in one day)	\$27.00 per hour

We require a non-working supervisor when five (5) or more positions are requested. A second non-working supervisor is required when fifteen (15) or more positions are requested. A third non-working supervisor is required when twenty-five (25) or more positions are requested.

Executive Specialist

\$30 per hour, plus expenses

An executive specialist is an extremely empowered individual who is an expert on how to get special tasks (i.e., attractions and special events) accomplished locally. This person will coordinate daily tasks, by prioritizing the work in the most efficient manner. Four (4) hour minimum will apply.

Registrar Speaker

\$150.00 per session

A speaker may be available to present the various attractions, events and history of Baltimore to your attendees at opening ceremonies, luncheons, orientations, etc. Max two (2) hours.

REGISTRATION PERSONNEL INFORMATION

Supervisor

Functions as the meeting planner's assistant. Must possess excellent delegation and supervisory skills and be firm yet approachable. Must be able to work without supervision and take responsibility for any task assigned by the meeting planner. Acts as liaison between registrars, the client and Visit Baltimore. Designates all breaks; monitors needs and reassigns or relieves jobs when necessary or requested by the client.

Registration Clerk

Staffs the main registration area. Duties include registering attendees, distributing information and giving directions. Maintains movement of the registration line through efficient interaction with attendees.

Cashier

Normally maintains cash received and/or credit card receipts for the meeting. All cashiers are bonded.

Computer/Data Entry Operators

Possess excellent computer skills.

Information/Message Desk (Kiosk)

Provides general information about Baltimore. Answers questions regarding participating hotels, conference programs, meeting rooms, dates and events. Upon request, provides information about area restaurants and makes reservations for attendees.

Room/Door Monitor

Monitors meetings and exhibitions by checking credentials. Requires the ability to be firm yet courteous and diplomatic.

Show Office

Distributes meeting information, both written and verbal. Must maintain a neat working environment. Becomes familiar with the names and positions of the association executives and how to contact them at all times. Learns dates, times and meeting/exhibit locations well enough to answer questions accurately.

Labor Personnel

Capable of lifting and moving boxes weighing in excess of 20 pounds.

The job descriptions are based on industry standards.

All staff is required by law to a 30-minute break after working four (4) hours or more. All breaks are paid.

PAYMENT

Payment is due within 30 days after receipt of the invoice. If payment is not received within 30 days, a late fee of 10% per month will be assessed.

LATE FEE

If registration request is received less than five (5) days prior to the start of the show, a fine of \$100.00 will be assessed.



CONVENTION REGISTRATION REQUEST

Return to: Convention Staffing Manager at
410-659-7313 (fax) or aperry@baltimore.org

Name of Organization: _____

Meeting Name: _____

Meeting Date(s): _____

Billing Address: _____

Contact name: _____

Phone: _____ Fax: _____

Person(s) to whom the registrars should report: _____

Where the registrars should report: Facility: _____

Area: _____

Please use one line per registrar and indicate if *casual dress* is permitted on any specific days.

Example

Date	Time	Position Title	Description of Duties
6/19/04	8:00am – 3:30pm	Registration Clerk/Badge Typist	Entering attendee names into computer terminals

Casual Dress on specific days: (Yes) (No) Days/Dates: _____

Index

All orders are governed by the GES Payment Policy and GES Terms & Conditions of Contract as specified in this Exhibitor Services Manual.

Natural Products Expo East / All Things Organic™ BioFach America
Baltimore Convention Center
September 13 - 15, 2018

A

Additional Official Vendor Order Forms, Page 174

Advance Shipping Labels, Page 120

Agreement and Rules and Regulations between GES and EAC, Page 157

Audio Visual, Page 174

B

Booth ID Sign Order Form, Page 105

Booth Layout - Hanging Signs, Page 152

Booth Regulations and Guidelines, Page 43

Booth Security , Page 185

Booth Staff, Page 257

C

Carpet Brochure, Page 68

Carpet Order Form, Page 69

Carpet Package Order Form, Page 70

Cartload Service Order Form, Page 129

Certificate of Insurance Instructions, Page 59

Certificate of Liability Insurance Sample, Page 159

Clean Floor Policy, Page 124

Cleaning and Porter Service Order Form, Page 142

Cleaning, Labor and Equipment, Page 142

Cold Storage Delivery Schedule, Page 137

Cold Storage Labor/Delivery Order Form, Page 136

Convenience Package Order Form, Page 96

Convention Center Regulations and Guidelines, Page 57

Critical Dates Checklist, Page 11

D

Digital File Preparation, Page 106

Direct Shipping Labels, Page 121

Do Not Refrigerate Shipping Label, Page 141

Domestic Third Party Billing Request, Page 31

E

Electrical & Plumbing Services (EDLEN), Page 161

Exhibitor Appointed Contractors (EACs) and Third Parties, Page 156

F

Fire Regulation Information, Page 60

Floral Order Form, Page 187

Forklift Order Form, Page 146

Freight Service Questionnaire, Page 126

Frozen Product Shipping Label, Page 139

Furniture & Accessories Order Form, Page 73

Furniture Package Order Form, Page 76

G

General Information, Page 63

GES Information and Order Forms, Page 4

GES Payment Policy, Page 160

083600172

080118

Index

All orders are governed by the GES Payment Policy and GES Terms & Conditions of Contract as specified in this Exhibitor Services Manual.

Natural Products Expo East / All Things Organic™ BioFach America
Baltimore Convention Center
September 13 - 15, 2018

GES Terms, Page 64

**GES Terms and Conditions of Contract,
Page 64**

GES Transportation Plus, Page 116

Graphics & Signage Order Form, Page 108

H

**Hand Carry/Cartload and Privately Owned
Vehicle Services, Page 110**

Hanging Sign Labor Information, Page 148

Hanging Sign Labor Order Form, Page 149

Hanging Sign Shipping Labels, Page 153

How to Navigate the ESK, Page 12

How to Save Money, Page 16

I

**Inbound Outbound Targeted Freight, Page
21**

**Installation and Dismantling Order Form,
Page 144**

**Instructions for Cold Storage Warehouse
Shipping and Delivery, Page 133**

Insurance, Page 191

**International 3rd Party Billing Request,
Page 32**

Internet and Telephone Services, Page 173

L

Lead Retrieval/Badge Scanner, Page 192

LIFO Booths, Page 20

**Low Refrigeration Catalog & Order Form,
Page 195**

M

**Marshaling Yard & Direct Deliveries
Information, Page 127**

**Material Handling/Drayage Information,
Page 113**

**Material Handling/Drayage Order Form,
Page 117**

N

**Non-Refrigerated Product Shipping Label,
Page 140**

**Notice of Intent to Use EAC and Policies
and Procedures, Page 156**

O

Operation of All Mechanical Lifts, Page 67

P

**Payment and Credit Card Charge
Authorization, Page 30**

**Pre-Printed Bill of Lading (BOL) / Outbound
Labels Request, Page 125**

Product Showcase, Page 19

R

**Refrigerated and Frozen Storage Order
Form, Page 134**

**Refrigerated Product Shipping Label, Page
138**

Refrigeration and Frozen Storage, Page 133

Regulations and Guidelines, Page 33

S

Sampling Guidelines, Page 176

Shipping Labels: Advance, Page 120

Shipping Labels: Direct, Page 121

083600172

080118

Index

All orders are governed by the GES Payment Policy and GES Terms & Conditions of Contract as specified in this Exhibitor Services Manual.

Natural Products Expo East / All Things Organic™ BioFach America
Baltimore Convention Center
September 13 - 15, 2018

**Shipping, Drayage and Material Handling,
Page 110**

Show Information, Page 8

Show Regulations and Guidelines, Page 33

Show Site Storage Order Form, Page 131

Show Site Work Rules, Page 61

Sneeze Guard Order Form, Page 77

Special Handling Brochure, Page 119

Specialty Furniture Brochure, Page 78

Specialty Furniture Order Form, Page 89

**Standard Exhibit Systems Brochure, Page
98**

**Standard Exhibit Systems Order Form, Page
103**

Standard Furniture Brochure, Page 71

Standard Graphics Brochure, Page 109

Stop. Think. Safety., Page 62

Sustainability Booth Options, Page 29

Sustainability Program, Page 28

T

Target Maps, Page 123

**Targeted Move-in and Freight Information,
Page 122**

Tips for New Exhibitors, Page 26

**Truss, Chain Hoist and Floodlight Order
Form, Page 154**

U

Utilities, Page 161

V

Vehicle Placement Order Form, Page 130

W

Welcome Letter, Page 5

083600172

080118