

A. STANDARD BOOTH

DEFINITION

One or more standard units in a straight line.

Height

Exhibit fixtures, components and identification signs will be permitted to a maximum height of 8'3" (2.5m).

Intent

If a portion of an exhibit booth extends above 8'3" (2.5m) high, the exhibit booth background will detract from the overall impact of the exhibit directly behind that booth regardless of how the rear of the offending exhibit is finished.

Depth

All display fixtures over 4'0" (1.22m) in height and placed within 10 lineal feet (3.05m) of an adjoining exhibit, must be confined to that area of the exhibitor's space which is at least 5'0" (1.52m) from the aisle line.

Intent

Each exhibitor is entitled to a reasonable sightline from the aisle regardless of the size of the exhibit. Exhibitors with larger space---30 lineal feet (9.14m) or more---should also be able to effectively use as much of the total floor space as possible as long as they do not interfere with the rights of others. The limitation on display fixtures over 4'0" (1.22m) and within 10 lineal feet (3.05m) of a neighboring exhibit is intended to accomplish both of these aims.

Structural Integrity

All exhibit fixtures, especially portable or "pop-up" booths must be erected in a manner to withstand normal contact or vibration due to outside forces such as wind, the movement of fork-lifts, heavy machinery or equipment, and unintentional contact on the part of cleaners, laborers or neighboring exhibitors. Exhibit fixtures should always be erected on a concrete floor (where possible) and the use of shelves and racks for product or literature display should only be attempted with fixtures designed to support such a loading.

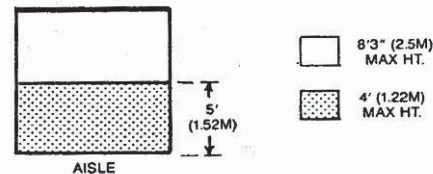
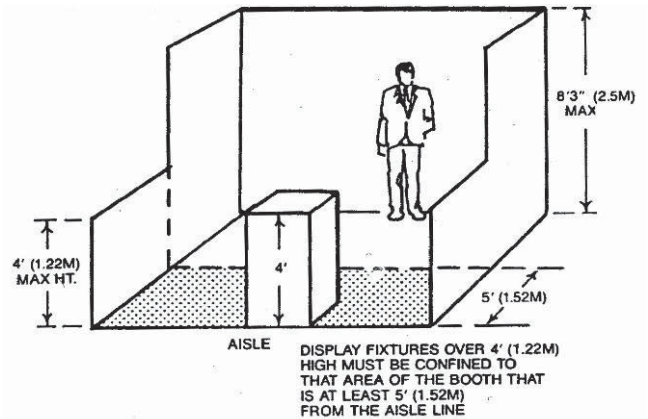
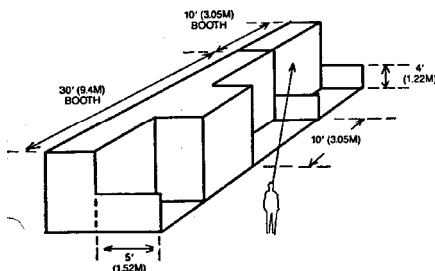

IMPORTANT: Space dimensions shown on floor plan are from centerline of booth equipment, such as side rails and/or back drape. Exhibit structures must be constructed to allow sufficient tolerance on each side for this equipment and for utility service at rear of booth.

Intent

Exhibitors adjoining portable or "pop-up" booths are entitled to reasonable safety precautions.

Storage

Exhibitors are reminded that the storage of excess literature, product, or packing materials and cases, behind the exhibit back drape is strictly prohibited in every major exhibit facility in the U.S. In most cases, a limited supply of literature and/or product may be stored within the booth area, as well as fire retardant shipping cases, as long as these materials do not block access to the utility service or appear unsightly from the aisle.

Intent

Exhibitors with small exhibit presentations who have purchased portable or "pop-up" displays and who do not require the services of the labor or drayage contractor, should be allowed to keep their materials within the confines of their rented booth space, as long as they do not create a safety problem or appear unsightly to the neighboring exhibits.

B. PERIMETER WALL BOOTH

DEFINITION

Standard booth located on the outer-perimeter wall of the exhibit floor.

Height

Exhibit fixtures, components and identification signs will be permitted to a maximum height of 12'0" (3.66m) in perimeter-wall booths.

Intent

Because the outer perimeter booths are not backed up against another exhibitor's booth, display back walls and materials over 8'3" (2.5m) will not interfere with or distract from any other exhibit booth.

Depth

All display fixtures over 4'0" (1.22m) in height and placed within 10 lineal feet (3.05m) of an adjoining exhibit, must be confined to that area of the exhibitor's space which is at least 5'0" (1.52m) from the aisle line.

Intent

Each exhibitor is entitled to a reasonable sightline from the aisle regardless of the size of exhibit. Exhibitors with larger space—30 lineal feet (9.14m) or more—should also be able to effectively use as much of the total floor space as possible as long as they do not interfere with the rights of others. The limitation on display fixtures over 4'0" (1.22m) and within 10 lineal feet (3.05m) of a neighboring exhibit is intended to accomplish both of these aims.

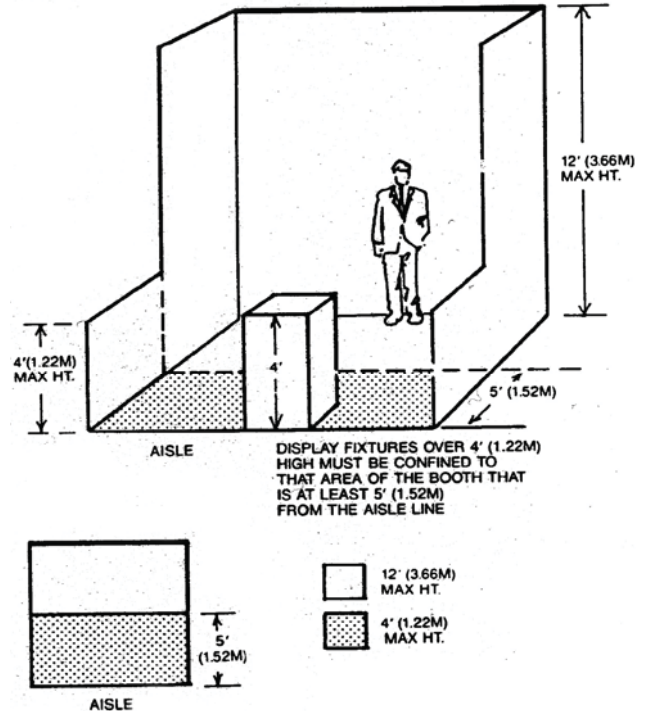

IMPORTANT: Space dimensions shown on floor plan are from center line of booth equipment, such as side rails and/or back drape. Exhibit structures must be constructed to allow sufficient tolerance on each side for this equipment and for utility service at rear of booth. Exhibitors considering a perimeter-wall booth in order to take advantage of the extra height permitted should design their exhibit so that it can be used either at the 8'0" (2.44m) height or the 12'0" (3.66m) height, so that it can be used in all future shows even if a perimeter-wall space is not available.

A. STANDARD BOOTH

DEFINITION

One or more standard units in a straight line.

Height

Exhibit fixtures, components and identification signs will be permitted to a maximum height of 8'3" (2.5m).

Intent

If a portion of an exhibit booth extends above 8'3" (2.5m) high, the exhibit booth background will detract from the overall impact of the exhibit directly behind that booth regardless of how the rear of the offending exhibit is finished.

Depth

All display fixtures over 4'0" (1.22m) in height and placed within 10 lineal feet (3.05m) of an adjoining exhibit, must be confined to that area of the exhibitor's space which is at least 5'0" (1.52m) from the aisle line.

Intent

Each exhibitor is entitled to a reasonable sightline from the aisle regardless of the size of the exhibit. Exhibitors with larger space---30 lineal feet (9.14m) or more---should also be able to effectively use as much of the total floor space as possible as long as they do not interfere with the rights of others. The limitation on display fixtures over 4'0" (1.22m) and within 10 lineal feet (3.05m) of a neighboring exhibit is intended to accomplish both of these aims.

Structural Integrity

All exhibit fixtures, especially portable or "pop-up" booths must be erected in a manner to withstand normal contact or vibration due to outside forces such as wind, the movement of fork-lifts, heavy machinery or equipment, and unintentional contact on the part of cleaners, laborers or neighboring exhibitors. Exhibit fixtures should always be erected on a concrete floor (where possible) and the use of shelves and racks for product or literature display should only be attempted with fixtures designed to support such a loading.

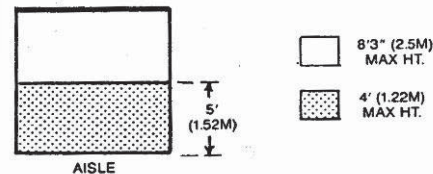
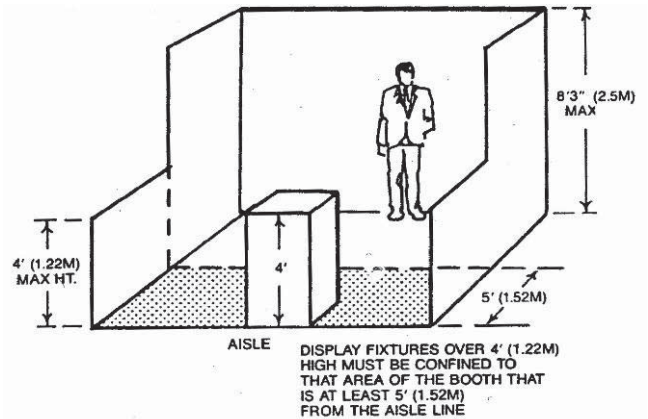
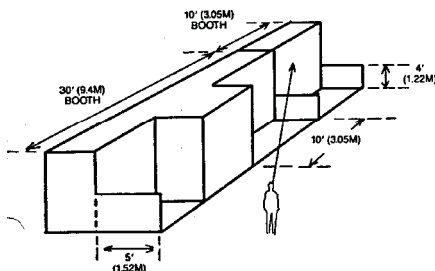

IMPORTANT: Space dimensions shown on floor plan are from centerline of booth equipment, such as side rails and/or back drape. Exhibit structures must be constructed to allow sufficient tolerance on each side for this equipment and for utility service at rear of booth.

Intent

Exhibitors adjoining portable or "pop-up" booths are entitled to reasonable safety precautions.

Storage

Exhibitors are reminded that the storage of excess literature, product, or packing materials and cases, behind the exhibit back drape is strictly prohibited in every major exhibit facility in the U.S. In most cases, a limited supply of literature and/or product may be stored within the booth area, as well as fire retardant shipping cases, as long as these materials do not block access to the utility service or appear unsightly from the aisle.

Intent

Exhibitors with small exhibit presentations who have purchased portable or "pop-up" displays and who do not require the services of the labor or drayage contractor, should be allowed to keep their materials within the confines of their rented booth space, as long as they do not create a safety problem or appear unsightly to the neighboring exhibits.

C. PENINSULA BOOTH

DEFINITION

Exhibit with one or more display levels in four or more standard units back to back with an aisle on three sides.

Height

Exhibit fixtures, components and identification signs will be permitted to a maximum height of 25'0" (7.63m), provided written approval is received from exposition management at least 60 days prior to the show.

Intent

When an exhibit in a peninsula booth configuration exceeds 8'3" (2.5m), it does not interfere with other exhibitors because it does not back up against another exhibitor back wall. The extra height is often needed to permit the open walk-through approach normally used in this type of location. The 25'0" (7.63m) height limitation has been set to avoid undue competition between exhibitors to see who can go the highest or be seen the farthest with each negating the others' efforts. Also, the 25'0" (7.63m) high exhibit will fit into almost any exposition center, thus permitting each exhibitor to get the maximum use of his or her exhibit.

Depth

All display fixtures over 4'0" (1.22m) in height and placed within 10 lineal feet (3.05m) of an adjoining exhibit in a standard booth, must be confined to that area of the exhibitor's space which is at least 5'0" (1.52m) from the aisle line. In the event that the adjoining exhibit is a peninsula booth, display fixtures will be permitted to a maximum height of 25'0" (7.63m) within the entire booth area since peninsula booths are normally "faced" towards the cross aisle and, in a back-to-back configuration, do not block the sightline into the adjoining peninsula booth.

Intent

Exhibitors adjoining peninsula exhibits are entitled to the same reasonable sightline from the aisle as they would expect if they were adjacent to an exhibitor with a standard booth.

Structural Integrity

All multi-story exhibits regardless of whether people will occupy the upper area or not, and all exhibit fixtures and components exceeding 12'0" (3.66m) in height must have drawings available for inspection by exposition management, the installation and dismantling contractor,

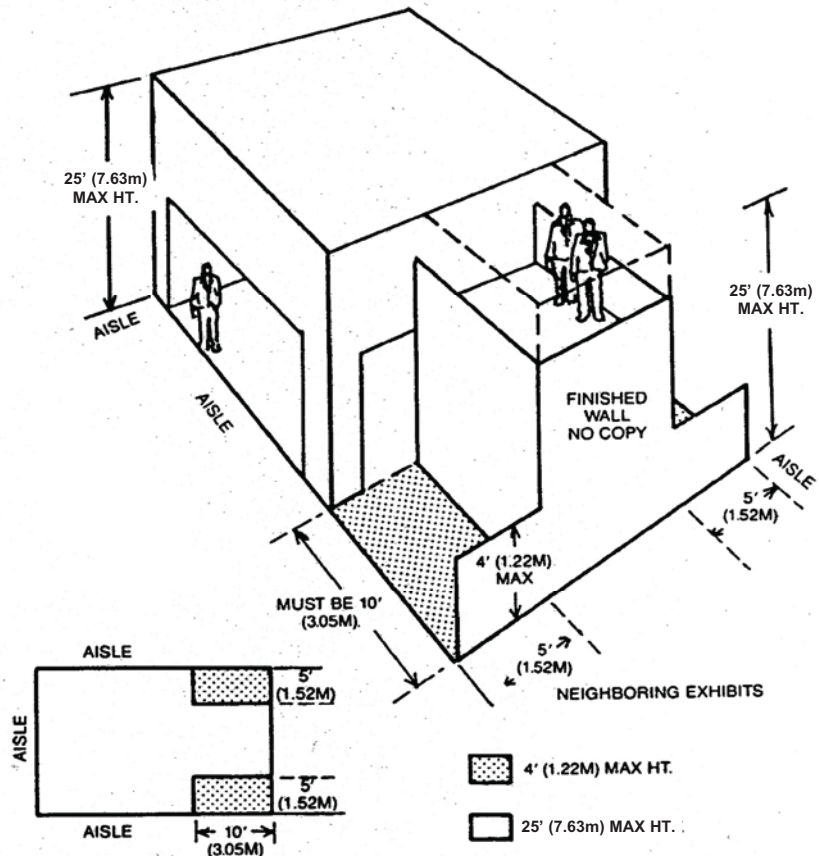

the exhibitor and governmental authority during the time the exhibit is being erected, exhibited and dismantled at the show site that includes a signature or stamp of a reviewing structural engineer indicating that the structure design is properly engineered for its proposed use, and a signature of an authorized official of the exhibit building company indicating that the structure is built in compliance with the details and specifications set forth on the drawings. Signs must also be posted indicating the maximum number of people the structure will accommodate.

Intent

Exhibitors in the vicinity of peninsula booth are entitled to the same reasonable safety precautions they would expect if they were adjacent to a standard booth.

IMPORTANT: Peninsula booths are normally "faced" towards the cross aisle. Any portion of the exhibitor's booth must have the backside of that portion finished and must not carry identification signs or other copy that would detract from the adjoining exhibit. Exhibitors are cautioned when installing a display with a ceiling or second level to check with the local fire department to insure that their display meets with the necessary fire safety precautions involving smoke alarms, fire extinguishers, sprinkler systems, etc.

D. ISLAND BOOTH

DEFINITION

Exhibit with one or more display levels in four or more standard units with aisles on all four sides.

Height

Exhibit fixtures and components will be permitted to a maximum height of 25'0" (7.63m). **Structures and hanging ID signs will be allowed to a height of 25' provided the exhibit is not in a height-restricted area of the convention center.**

Intent

When an island booth exceeds 8'3" (2.5m), it does not interfere with other exhibitors because it obviously does not back up against another exhibitor's back wall. The extra height is often required in an island booth exhibit to permit the open walk-through approach normally used in this type of location. The 25' maximum height limitation has been set to avoid undue competition between exhibitors to see who can go the highest or be seen the farthest with each negating the other's efforts. Also, the 25' high exhibit will fit into most exposition centers, thus permitting each exhibitor to get the maximum use of his or her exhibit.

Depth

Because an island booth is automatically separated by the width of an aisle from all neighboring exhibits, full use of the floor plan is permitted.

Openings: **NEW RULE**

Island booths must have a minimum of 10' wide entrance/opening every 30'. Exhibits that exceed 100' must leave a minimum 10' aisle free of signs, displays, products, fixtures or decorations, but must be carpeted by the exhibitor consistent with the exhibit carpet.

Intent

When an island booth structure exceeds 30' in width it has the potential of blocking the sightline for adjacent booths.

Structural Integrity

All multi-story exhibits, regardless of whether people will occupy the upper area or not, and all exhibit fixtures and components exceeding 12'0" (3.66m) in height must have drawings available for inspection by exposition management, the installation and dismantling contractor, the exhibitor and governmental authority during the time the exhibit is being erected, exhibited and dismantled at the show site that include a signature of stamp of a reviewing structural engineer indicating that the structure design is properly engineered for its proposed use, and a signature of an authorized official of the exhibit building company indicating that the structure is built in compliance with the details and specifications set forth on the drawings. Signs must also be posted indicating

the maximum number of people the structure will accommodate.

Intent

Exhibitors in the vicinity of island exhibits are entitled to the same reasonable safety precautions they would expect if they were adjacent to a standard booth.

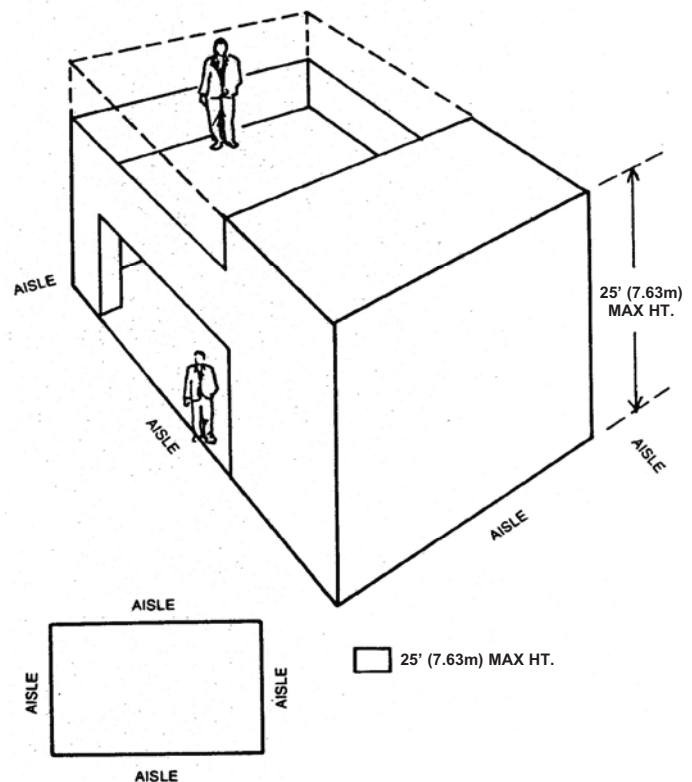

IMPORTANT: Exhibitors are cautioned when installing a display with a ceiling or second level to check with the local fire department to insure that their display meets with the necessary fire safety precautions involving smoke alarms, fire extinguishers, sprinkler systems, etc.

E. CANOPIES & CEILINGS

DEFINITION

An exhibit component supported over an exhibitor's space for decorative purposes only.

Height

Canopies, false ceilings and umbrellas will be permitted to a height that corresponds to the height regulation for the appropriate exhibit configuration of which they are a part. For example, canopies will not exceed 8'3" (2.5m) in height in a standard booth configuration. Furthermore, the canopy or false ceiling will not exceed 1'0" (30m) in depth and cannot be used for identification or display purposes.

Intent

Exhibitors requiring canopies or false ceilings to create the desired exhibit environment within their booth space should be allowed to do so as long as the canopy and its support structure does not violate the intent of the height or depth regulation.

Depth

Canopies may extend out to the aisle line and up to the booth line on either side of an exhibitor's space providing that the support structure will not exceed 3" (7.62cm) in width when placed within 10 lineal feet (3.02m) of an adjoining exhibit and not confined to that area of the exhibitor's space which is at least 5'0" (1.52m) from the aisle line. Furthermore, canopies, false ceilings or umbrellas will not be used for identification or display purposes except as would normally be allowed for any exhibit component within the regulations set forth for the exhibit configuration.

Intent

Exhibitors adjoining exhibits with canopies are entitled to the same reasonable sight line from the aisle, as they would expect if they were adjacent to an exhibitor with a standard booth.

IMPORTANT: Exhibitors are cautioned when installing a display with a ceiling or second level to check with the local fire department to insure that their display meets with the necessary fire safety precautions involving smoke alarms, fire extinguishers, sprinkler systems, etc.

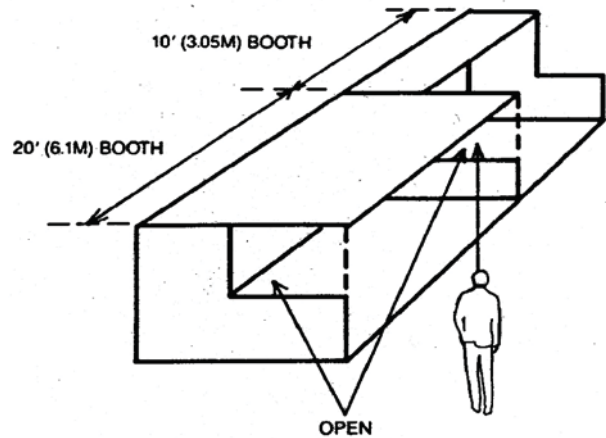
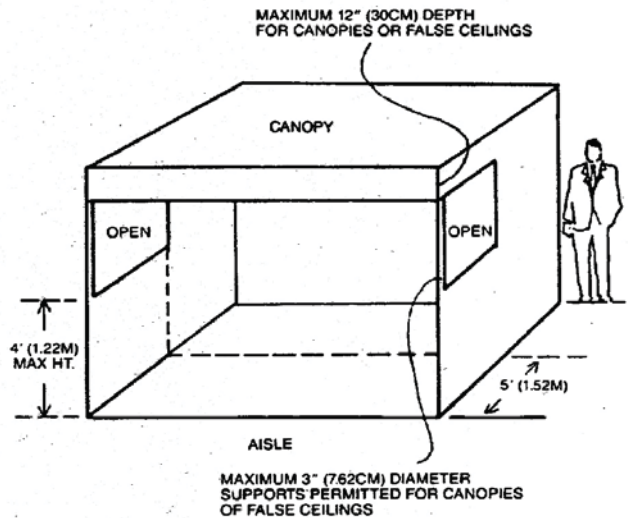

F. Booth Structure

Height/Depth

Booth structures will be permitted to a height and depth that correspond to the height and depth regulations for the appropriate exhibit configuration of which they are a part. For example, structures that are part of a peninsula exhibit will not exceed 25'0" (7.63m) in height, and will not be placed within 10 lineal feet (3.05m) of a neighboring exhibit unless they are confined to that area of the exhibitor's space which is at least 5'0" (1.52m) from the aisle line to avoid blocking the sight line from the aisle to the adjoining booth.

Intent

Structures are part of the overall exhibit presentation and, therefore, must be treated as a component of the total exhibit configuration. The maximum height and depth regulations have been set to avoid undue competition between exhibitors to see who can go the highest or be seen the farthest, while also assuring exhibitors who are adjoining exhibits with structures of the same reasonable sight line from the aisle as they would expect if they were adjacent to an exhibitor with a standard booth.

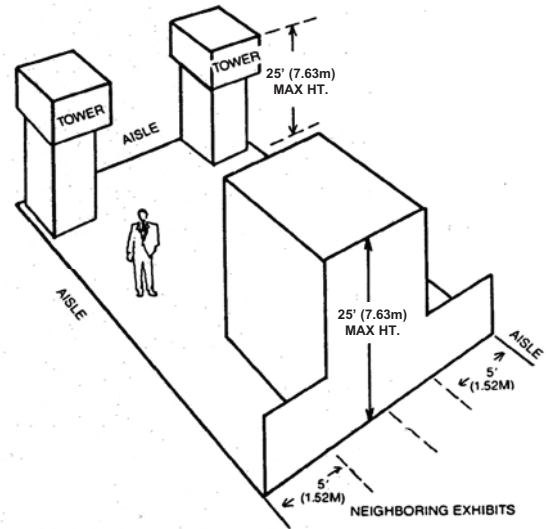

Structural Integrity

All structures in excess of 12'0" (3.66m) must have drawings available for inspection by exposition management, the installation and dismantling contractor, the exhibitor and governmental authority during the time the tower is being erected, exhibited and dismantled at the show site that include a signature or stamp of a reviewing structural engineer indicating that the structure designed is properly engineered for its proposed use, and a signature of an authorized official of the exhibit building company indicating that the structure is built in compliance with the details and specifications set forth on the drawings.

Intent

Exhibitors adjoining exhibits with structures are entitled to the same reasonable safety precautions they would expect if they were adjacent to a standard booth

G. HANGING SIGNS

DEFINITION

An exhibit component suspended above an exhibit of four or more standard units back to back with an aisle on at least three sides for the purpose of displaying graphics or identification.

Height

Hanging identification signs and graphics will be permitted to a maximum height of 25'0". Hanging signs are allowed over island and peninsula booths ONLY. Inline, or standard booths may not hang signs over their booth at this AUSA event.

Intent

Hanging signs are part of the overall exhibit presentation and, therefore, must be treated as component of the total exhibit configuration. All signs, whether suspended or attached to the exhibit fixture, will be permitted to a maximum height that corresponds to the appropriate exhibit configuration.

Depth

All hanging signs must be set back at least 25% of the booth's width dimension from the backline of the booth.

Intent

Hanging signs, must be double-faced, should be set back within the exhibitor's space so as not to detract from the overall impact of the exhibit that is directly adjacent.

Size

Hanging signs and graphics will be permitted to a total length on each side of the exhibitor's space that does not exceed 50% of the corresponding dimension of the booth.

Intent

The size and number of hanging signs must be limited in order to minimize the stress to the facility ceiling structure on the part of any one exhibitor.

Structural Integrity

Hanging signs and graphics will be permitted to be hung from the appropriate load-bearing points within the exhibit facility provided written approval is received from the exhibit facility 60 days prior to the show. All hanging signs must have drawings available for inspections by exposition management, the installation and dismantling contractor, the facility manager, the exhibitor, and governmental authority during the time the component is being hung, suspended and removed at the show site that include a signature or stamp or a reviewing structural engineer

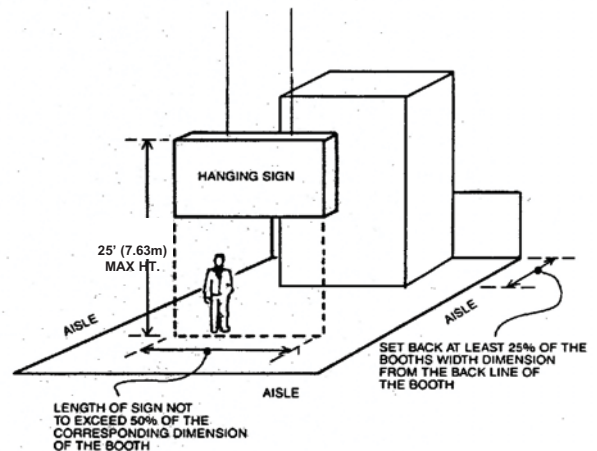

indicating that the structure is built in compliance with the details and specifications set forth on the drawings. (Note: Exhibitors are encouraged to use lightweight materials in the construction of a hanging sign to eliminate excess stress to the facility ceiling structure.)

Intent

Exhibitors in adjoining booths with hanging signs are entitled to the same reasonable safety precautions they would expect if they were adjacent to a standard booth.

H. SPLIT ISLAND BOOTH

DEFINITION

A Split Island Booth is a Peninsula Booth which shares a common back wall with another Peninsula Booth. The entire cubic content of this booth may be used, up to the maximum allowable height, without any back wall line of sight restrictions. Twenty five ft. (25') is the maximum height allowance, including signage. The entire cubic content of the space may be used up to the maximum allowable height of 25'.

I. DEMONSTRATIONS

DEFINITION

The part of the exhibit program involving the interaction of exhibit personnel and their audience through corporate presentations, product demonstrations or sampling.

Regulation

Demonstration areas must be organized within the exhibitor's space so as not to interfere with any traffic aisle and sampling or demonstration tables must be placed a minimum of 2'0" (60cm) from the aisle line. Should spectators or samplers interfere with the normal traffic flow in the aisle or overflow into neighboring exhibits, exposition management will have no alternative but to request that the presentation or sampling be eliminated.

Intent

The aisles are the property of the entire show and each exhibitor has the responsibility to assure proper flow of traffic through the entire show. When large crowds gather to watch a demonstration or for sampling and interfere with the flow of traffic down aisle or create excessive crowds in neighboring booths, it is an infringement on the rights of other exhibitors. Aisles must not be obstructed at any time.

Sound

Exhibitors must police their own booths to be sure the noise levels from demonstrations or sound systems is kept to a minimum and does not interfere with others. Remember the use of sound systems or equipment that produces sound is an exception to the rule, not a right. Exposition management reserves the right to determine at what point sound constitutes interference with others and must be discontinued.

Safety Precautions

All product demonstrations involving any moving and potentially hazardous machines, displays or parts must have hazard barriers to prevent accidental injury to spectators. Demonstrations must always be supervised by exhibitor personnel who can stop the demonstration in the event of an emergency and all demonstrations involving potentially hazardous by-products, such as dust, fumes, sparks or flames, must be approved in writing by exposition management 60 days prior to the show.

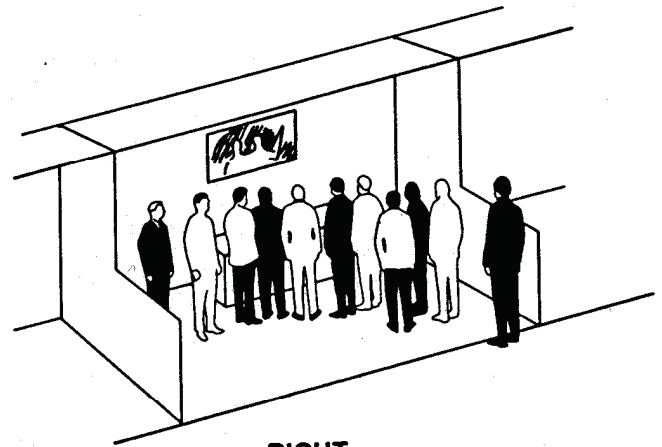

RIGHT

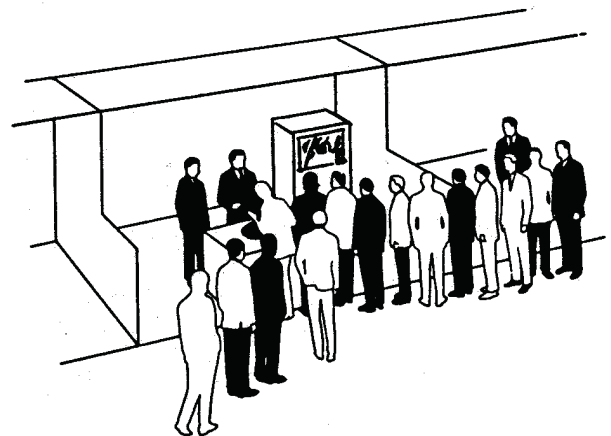

WRONG