

Exhibitor Services Manual Table of Contents

All orders are governed by the GES Payment Policy and GES Terms & Conditions of Contract as specified in this Exhibitor Services Manual.

Seattle International Auto Show
CenturyLink Field Event Center
November 10 - 13, 2016

GES Information and Order Forms	3
Show Information	4
Show Information	4
General Information	6
Tips for New Exhibitors	7
Required Forms	9
Payment and Credit Card Charge Authorization	9
Domestic Third Party Billing Request	10
International 3rd Party Billing Request	11
Booth Furnishings	12
Carpet Brochure	12
Carpet Order Form	13
Carpet Package Order Form	14
Standard Furniture Brochure	15
Furniture & Accessories Order Form	17
Furniture Package Order Form	20
Specialty Furniture Brochure	21
Specialty Furniture Order Form	30
Convenience Package Order Form	36
Standard Exhibit Systems Brochure	38
Standard Exhibit Systems Order Form	45
Digital File Preparation	47
Graphics & Signage Order Form	49
Standard Graphics Brochure	50
Shipping, Drayage and Material Handling	51
Material Handling/Drayage Information	51
GES Transportation Plus	54
Material Handling/Drayage Order Form	55
Special Handling Brochure	57
Advance Shipping Labels	58
Direct Shipping Labels	59
Pre-Printed Bill of Lading (BOL) / Outbound Labels Request	60
Freight Service Questionnaire	61
Marshaling Yard & Direct Deliveries Information	62
Move In Routes	63
Show Site Storage Order Form	64
Cartload Service Order Form	66
Labor and Equipment	67
Labor Information and Regulations	67
Installation and Dismantling Order Form	68

061600445

101116

Exhibitor Services Manual Table of Contents

All orders are governed by the GES Payment Policy and GES Terms & Conditions of Contract as specified in this Exhibitor Services Manual.

Seattle International Auto Show
CenturyLink Field Event Center
November 10 - 13, 2016

Forklift Order Form	70
Hanging Sign / Truss Labor Information	72
Hanging Sign Labor Order Form	73
Booth Layout - Hanging Signs	77
Hanging Sign Shipping Labels	78
Cleaning and Porter Service Order Form	79
Exhibitor Appointed Contractors (EACs) and Third Parties	80
Notice of Intent to Use EAC and Policies and Procedures	80
Agreement and Rules and Regulations between GES and EAC	81
Certificate of Liability Insurance Sample	83
Regulations and Guidelines	84
Show Site Work Rules	84
Stop. Think. Safety.	85
Fire Regulation Information	86
Operation of All Mechanical Lifts	88
GES Payment Policy	89
GES Terms and Conditions of Contract	90
Additional Service Order Forms	93
Electrical	94
Electrical 24 Hour Power Notice	100
Telecom/Internet	101
Floral Services	104
Index	105

061600445

101116

One Place for Exhibit Planning Ordering and Management

ExpressoSM by GES is a simple to navigate, picture-driven system customized specifically for your show.

It's more than just your exhibitor manual online.

Exhibitors can:

- Order exhibit products and services for multiple booths
- View account order history
- View important show and event information
- Track small packages and inbound shipments
- Download the show schedule into Outlook or iCalendar
- Print shipping labels
- Chat with our award-winning GES National ServicerSM

Order Everything You Need for Your Show



- Go to <https://e.ges.com/061600445/esm>
- Log in or sign up with a new account
- Browse products and services and you will be guided through the ordering process

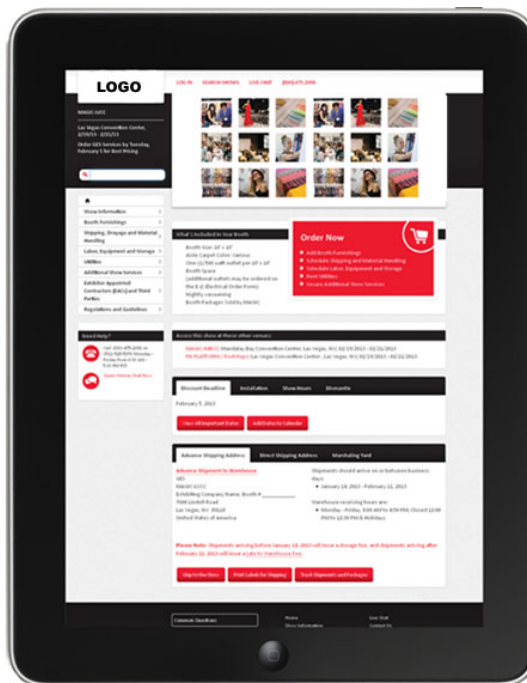

All orders are governed by the GES Payment Policy and GES Terms & Conditions of Contract as specified in this Exhibitor Services Manual.

Seattle International Auto Show
CenturyLink Field Event Center
November 10 - 13, 2016

Questions?



Contact

- Chat with us <http://www.ges.com/chat>
- Contact us online: <https://e.ges.com/061600445/contactus/esm>

Official Service Provider

Global Experience Specialists, Inc. (GES) Phone (in USA): 800.475.2098 International Calls: 702.515.5970
7000 Lindell Road FAX (in USA): 866.329.1437 International Faxes: 702.263.1520
Las Vegas, NV 89118-4702

GES will be onsite to assist you in coordinating any last minute services, order additional products, and to answer any questions you may have.

Discount Deadline Date

Friday, October 21 GES orders must be received with payment by this date.

Exhibitor Move In

Tuesday, November 8 9:00 AM - 11:59 PM Per Target Schedule provided by Motor Trend Auto Shows LLC

Wednesday, November 9 12:01 AM - 11:59 PM

Thursday, November 10 12:01 AM - 10:00 AM

Please take notice - this event moves in on overtime, all applicable surcharges will apply

Show Hours

Thursday, November 10 2:00 PM - 9:00 PM

Friday, November 11 12:00 PM - 9:00 PM

Saturday, November 12 9:00 AM - 9:00 PM

Sunday, November 13 9:00 AM - 6:00 PM

Exhibitor Move Out

Sunday, November 13 6:00 PM - 11:59 PM Booth Exhibitors Need To Complete Move Out By 11:00pm

Monday, November 14 12:01 AM - 11:59 PM OEM's in West Hall, East Hall, & Concourse need to have all displays crated by 3pm and complete move out by midnight Monday.

Tuesday, November 15 12:01 AM - 5:00 PM OEM's in North Hall need to have all displays crated by 12pm and complete move out by 5pm Tuesday.

Please take notice - this event moves out on overtime, all applicable surcharges will apply.

Carrier Check-in Post-Show

Tuesday, November 15 11:00 AM Carriers post-show must be checked-in by this time.

Facility Clear

Tuesday, November 15 5:00 PM All exhibitor materials must be removed.

101116 061600445

G-1 091316

Shipping Addresses: Use provided Shipping Labels in this Exhibitor Services Manual to expedite handling

Advance Shipments to Warehouse:

c/o GES
Seattle International Auto Show
(Your Company Name & Booth Number)
4060 Lind Avenue SW
Renton, WA 98057
USA

Shipments should arrive on or between:

October 10 - November 1, 2016
Hours for receiving are Monday - Friday, 7:30 AM - 3:30 PM

Direct Shipments to Show Site:

c/o GES
Seattle International Auto Show
(Your Company Name & Booth Number)
CenturyLink Field Event Center
1000 Occidental Avenue South
Seattle, WA 98134-1245
USA

Shipments should arrive on:

November 8, 2016, 9:00 AM - 11:59 PM

Marshaling Yard Site Address:

c/o GES
Seattle International Auto Show
(Your Company Name & Booth Number)
700 Occidental Ave. South
Seattle, WA 98104
USA

101116 061600445

G-1 091316



General Information

All orders are governed by the GES Payment Policy and GES Terms & Conditions of Contract as specified in this Exhibitor Services Manual.

Seattle International Auto Show
CenturyLink Field Event Center
November 10 - 13, 2016

What is an Official Service Provider?

- GES has been selected as the Official Service Provider by the show organizer to design and produce your show.
- We can save you time and money with our insight and experience of the show process. As the Official Service Provider GES will assist you in your pre-show planning from start to finish.
- We are at your service for all your exhibiting needs.

GES Show Services

- Booth Furniture and Accessories
- Custom Exhibits
- Graphics
- Installation and Dismantle Services
- Overhead Lighting and Rigging

Work Zone



- Customer acknowledges that the show site and surrounding areas are active work zones. Customer, its agents, employees and representatives are present on the show floor at their own risk.

How Can I Order My Show Services?



Expresso is GES' planning, ordering and management system. Order everything you need for your tradeshow exhibits, view account order history, download the show schedule and more.

- Go to <https://e.ges.com/061600445/esm>
- Log in or sign up with a new account
- Browse products and services and you will be guided through the ordering process



GES National Servicenter® provides consistency and continuity of customer service for exhibitors at shows:

- Phone: (800) 475-2098 / Fax: (866) 329-1437
- International phone: (702) 515-5970 / Fax: (702) 263-1520
- Contact us online: <https://e.ges.com/061600445/contactus/esm>

GES Servicenter® is onsite to place any last minute orders and provide show information while at showsite.

Exhibitor Services

- Our Exhibitor Services team is responsible for answering exhibitor questions, processing your orders and handling any special requests.

101116 061600445

101116

G-11 031716

Tips for New Exhibitors

All orders are governed by the GES Payment Policy and GES Terms & Conditions of Contract as specified in this Exhibitor Services Manual.

Seattle International Auto Show
CenturyLink Field Event Center
November 10 - 13, 2016

First Time Exhibitors

Exhibiting for the first time can be confusing and stressful. GES is here to make your ordering process as simple and stress free as possible. GES will be onsite at your show to assist you in coordinating any last minute services, order additional products and answer any questions you may have. Save money by ordering early! Order by the Discount Deadline of October 21, 2016 for best pricing.

For quick and easy ordering, visit the Espresso online ordering site: <http://e.ges.com/061600445/esm>

Details Matter When Shipping

Material Handling is the unloading of your exhibit materials. The service includes delivery to your booth, handling of empty containers to and from storage and removal of your materials from your booth for reloading onto your outbound carrier. This is not to be confused with the cost to transport your exhibit material to and from the event.

- Unloading the freight and delivery to your booth is not included. Avoid unexpected costs at show site and estimate the cost for this service. <http://e.ges.com/061600445/item/200500>
- We understand that your calculation is only an estimate. Invoicing will be done from the actual weight. Adjustments will be made accordingly.
- Save by combining shipments. A minimum charge applies for each shipment under 200 lbs.
- Make sure that a Bill of Lading is filled out completely for each shipment.
- Confirm that your driver has the correct dates and times that your shipment needs to be delivered and picked up.
- Use provided shipping labels to make sure show name, booth number and other vital information is provided.

Shipping, Drayage and Material Handling: <http://e.ges.com/061600445/shippinghandling/esm>

Dot Your I's and Cross Your T's

Please be aware that a valid credit card is required for all forms of payment. We require your credit card charge authorization to be on file with GES even if you are paying by check or wire transfer.

- Make sure your credit card information is complete and correct, including the expiration date.
- Review GES Payment Policy and the Terms and Conditions of Contract
- Clearly indicate when paying by check. All check payments should be returned to:

Global Experience Specialists, Inc. (GES)
Bank of America
P.O. Box 96174
Chicago, IL 60693

Bank ACH/wire transfer payment information

Beneficiary:	Global Experience Specialists	If requested, following is the physical address for routing identifiers: Bank of America, Wire Transfer-Customer Services 2000 Clayton Road Concord, CA 94520 USA
c/o Bank of America	(GES)	
901 Main Street,	Account #: 7188101819	
TX1-492-07-14	Wire ABA Routing #: 026009593	
Dallas, TX 75202-3714 USA	ACH ABA Routing #: 071000039	
Telephone # 702-263-2795 or 702-914-5112	SWIFT Address: BOFAUS3N CHIPS Address: 0959	

For ACH/Wire Transfer send the following information to GES via email to Cash Application Team at cashapplication@ges.com.

- Exhibiting company name, show name, show facility
- Date and amount of wire transfer
- Bank and country where transfer originated



No Tipping Required

GES work rules prohibit the solicitation or acceptance of tips in cash, products or gifts of any kind by any employee. Our employees are paid appropriate wages denoting professional status; therefore, tipping of any kind is not allowed.

Where Did My Crates Go?

After your exhibit is set-up and your products displayed, you must place "empty" stickers on your empty containers for storage during the show. At show site a kiosk with a floor plan and color coded "empty" stickers will be available. Crews will clear the floor of all "empty" stickered containers to clear room for other freight.

- Simply write your booth number, company and show name on the sticker and place the container in the aisle. It will be stored throughout the exposition and then returned to your booth upon show close.
- Place stickers on all 4 sides of the crate.
- Please label your empty containers as soon as possible to keep your area clear and make it easier to prepare your booth.

Don't Forget to Take Out the Trash

Exhibitors planning on disposing of booth properties and/or floor covering at the end of the show should pre-order this service. In the event that excessive booth properties and/or floor covering are abandoned/left on the floor at the conclusion of a move-out, a dumpster fee will be billed to the exhibiting company.

Keeping Up Appearances

Pay close attention to your booth size when ordering items based on booth sq. footage or quantity of decorating items. Please do not order more than what will comfortably fit in your space.

- Exhibitors that order two (2) – standard pre-cut carpet pieces should keep in mind that there will be a visible seam where the pieces of carpet are placed together. GES cannot guarantee that carpet colors will be an exact match due to dye lot differences.
- Order just enough carpet to fit your standard booth space. A 10' x 10' booth should not order 10' x 20' carpet.
- We custom cut carpet to fit your needs.

It's All About the Padding

Ordering carpet for your booth? Think about what kind padding you need if you are going to be on your feet a lot. That little extra cushion can make all the difference at the end of the day.

Carpet and Padding: <http://e.ges.com/061600445/carpet/esm>

What Goes Up Must Come Down

If labor is needed for your booth space at the time of move-in, you will also need labor for move-out. Remember, what you put up must be taken down.

- See Labor Information form for rules specific to your show. Work rules can vary based on show location.
- Gratuities in any form, including cash, gifts, or labor hours for work not actually performed are prohibited by GES.
- All rates are subject to change if necessitated by increased labor and material costs.
- Pre-order labor to save.

Labor Services: <http://e.ges.com/061600445/LaborandEquipment/esm>

Carpet

Standard

13 oz. is conventional filament nylon carpet that is re-used for pre-cut sizes and new for custom-cut orders.

Includes:

- 13 oz. 100% recyclable color options include  Blue Jay, Pepper, and Black.
- Custom Cut includes 4 mil poly covering
- Available in pre-cut sizes
- Installation and pick-up at the close of the show
- Front edge taping



Black (41) 



Blue (42)

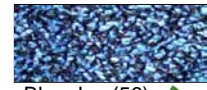

Blue Jay (56) 



Gray (40)

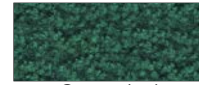

Green (45)



Pepper (52) 



Red (49)

Plush

26 oz. premium carpet is 100% recyclable. Same industry tradeshow performance standards as conventional carpet, but helps to reduce the volume of excess materials from entering landfills.

Includes:

- 26 oz. 100% recyclable carpet 
- 4 mil poly covering for protection
- Anti-static treatment
- 3M Scotchgard™ protection
- Installation and pick-up at the close of the show
- Front edge taping



Cement (70)



Charcoal (71)



Cobalt (72)

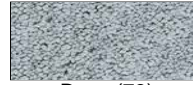

Dove (73)

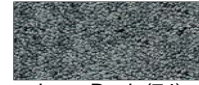

Lava Rock (74)

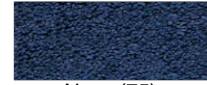

Navy (75)



Onyx (76)



Red (49)

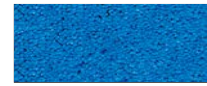

Royal Blue (77)



Silky Beige (78)



Silver (79)



Snow (80)

Ultra Plush

50 oz. premium carpet is 100% recyclable. Same industry tradeshow performance standards as conventional carpet, but helps to reduce the volume of excess materials from entering landfills.

Includes:

- 50 oz. 100% recyclable carpet 
- 4 mil poly covering for protection
- Anti-static treatment
- 3M Scotchgard™ protection
- Installation and pick-up at the close of the show
- Front edge taping

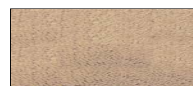

Bisque (81)



Black (41)

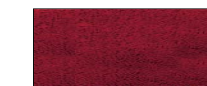

Cabernet (82)

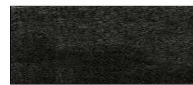

Graphite (83)



Iceberg (84)



Midnight (85)



Seascape (86)



Sterling (87)



Teal (55)

 The leaf symbol indicates recyclable or eco-friendly materials, per manufacturer's specifications.

Colors may vary due to facility lighting, printing limitations and dye lot differences. Some items may not be available at all locations. See order form for details. Styles of items portrayed on this brochure may vary in some locations.

Carpet Order Form

All orders are governed by the GES Payment Policy and GES Terms & Conditions of Contract as specified in this Exhibitor Services Manual.

Seattle International Auto Show
CenturyLink Field Event Center
November 10 - 13, 2016

Discount Deadline Date:
October 21, 2016

Company Name _____ Email _____ Phone Number _____ Booth Number _____



Easy Ordering Tips:

- All prices include delivery, rental, and removal.
- Return your orders three (3) weeks before show move-in to ensure availability. At show site color options and grades may not be available and substitutions might be necessary.
- Do you have a booth larger than 300 Sq. Ft., an island or peninsula? Order Custom-Cut carpet! (Minimum 100 Sq. Ft. order required.)

Carpet

13 oz. Color Options

(Gray will be provided if no color is indicated below)

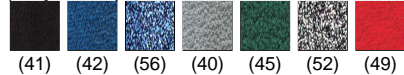

26 oz. Plush Color Options

(Dove will be provided if no color is indicated below)

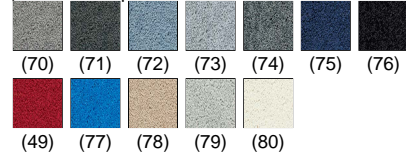

50 oz. Ultra Plush Color Options

(Iceberg will be provided if no color is indicated below)

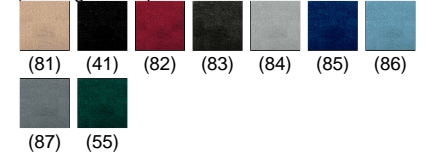

Item Code	Description	Color Code	Discount (\$)	Regular (\$)	Qty	Tax %	Total
5001	Pre-Cut 13 oz. Standard Carpet 10'x10'		149.50	224.50		9.6	\$
5002	Pre-Cut 13 oz. Standard Carpet 10'x20'		294.00	441.25		9.6	\$
5003	Pre-Cut 13 oz. Standard Carpet 10'x30'		449.50	674.50		9.6	\$

Calculate Sq. Ft. = Width _____ X Length _____ = _____ Total Sq. Ft.

Item Code	Description	Color Code	Discount (\$)	Regular (\$)	Sq. Ft.	Tax %	Total
5000	13 oz. Carpet Custom-Cut, Per Sq.Ft.		2.52	3.76		9.6	\$
5006	26 oz. Plush Carpet Custom-Cut, Per Sq.Ft.		3.61	5.40		9.6	\$
5007	50 oz. Ultra Plush Carpet Custom-Cut, Per Sq.Ft.		4.37	6.55		9.6	\$

Item Code	Description	Discount (\$)	Regular (\$)	Sq. Ft.	Tax %	Total
500400	Carpet Padding, 1/2" Thick, Per Sq.Ft.	1.19	1.81		9.6	\$

Item Code	Description	Discount (\$)	Regular (\$)	Sq. Ft.	Tax %	Total
500410	Carpet Plastic Covering, Per Sq.Ft.	0.60	0.85		9.6	\$
500420	Plastic Covering Per Square Foot, Reinforced	0.62	0.90		9.6	\$

Electrical or Utilities Under Carpet?

Yes No

Total and Sign: Return to Fax: 866.329.1437 • International Fax: 702.263.1520

Please Sign

X

Authorized Signature

Authorized Name - Please Print

Date

I agree in placing this order that I have accepted GES Payment Policy and GES Terms & Conditions of Contract, including authorization for GES to retain personal information to better serve my need for GES services at future events.

Total Payment Enclosed

\$

Cancellation Policy: Custom Size Booth Carpet cancelled after being cut will be charged **100%**. All other carpet cancelled will be charged 50% of original price after move-in begins and **100%** of original price after installation.

061600445

101116

C-1 100316



Carpet Package Order Form

All orders are governed by the GES Payment Policy and GES Terms & Conditions of Contract as specified in this Exhibitor Services Manual.

Seattle International Auto Show
 CenturyLink Field Event Center
 November 10 - 13, 2016

Discount Deadline Date:
 October 21, 2016

Company Name _____ Email _____ Phone Number _____ Booth Number _____



Easy Ordering Tips:

- All prices include delivery, rental, and removal.
- Return your orders three (3) weeks before show move-in to ensure availability. At show site some colors and grades may not be available and substitutions might be necessary.
- A minimum of 100 square feet is required for all custom-cut carpet package orders.

Carpet Packages

13 oz. Color Options

(Gray will be provided if no color is indicated below)

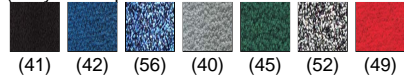

26 oz. Plush Color Options

(Dove will be provided if no color is indicated below)

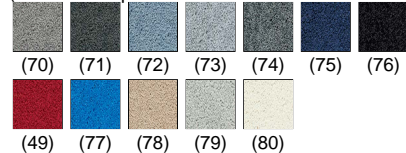

50 oz. Ultra Plush Color Options

(Iceberg will be provided if no color is indicated below)

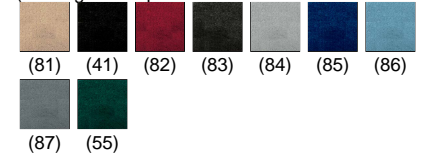

Item Code	Description	Color Code	Discount (\$)	Regular (\$)	Sq. Ft.	Tax %	Total
400021	13 oz. Carpet Package, Per Sq.Ft.		3.63	5.45		9.6	\$
	↳ Includes 10% Off: 13 oz. Standard Custom-Cut Carpet, Padding, Visqueen and 4 Day(s) Cleaning.						
400022	26 oz. Plush Carpet Package, Per Sq.Ft.		4.61	6.92		9.6	\$
	↳ Includes 10% Off: 26 oz. Plush Custom-Cut Carpet, Padding, Visqueen, and 4 Day(s) Cleaning.						
400023	50 oz. Ultra Plush Carpet Package, Per Sq.Ft.		5.29	7.96		9.6	\$
	↳ Includes 10% Off: 50 oz. Ultra Plush Custom-Cut Carpet, Padding, Visqueen, and 4 Day(s) of Cleaning.						

Electrical or Utilities Under Carpet?

Yes No



- Save money by pre-ordering labor for installation for stairs, platforms, risers or meeting rooms.
- Return your orders before the discount deadline to receive the best price.

Total and Sign: Return to Fax: 866.329.1437 • International Fax: 702.263.1520

Please Sign

X

Authorized Signature

Authorized Name - Please Print

Date

I agree in placing this order that I have accepted GES Payment Policy and GES Terms & Conditions of Contract, including authorization for GES to retain personal information to better serve my need for GES services at future events.

Total Payment Enclosed

\$

Cancellation Policy: Custom Size Booth Carpet cancelled after being cut will be charged **100%**. All other carpet cancelled will be charged **50%** of original price after move-in begins and **100%** of original price after installation.

061600445

101116

C-2 100616



Furniture and Accessories

Chairs



300051 - Chair, Contemporary Arm, 23"W 18"D 31"H



300052 - Chair, Contemporary Side, 19.5"W 18"D 31"H



300050 - Chair, Plastic Contour, 18"W 18.5"D 32"H



300053 - Stool, Contemporary, 17"W 18"D 48"H

Tables



300057 - Table, Rectangle, 24"x36"x30" High



300056 - Table, Square, 24"x24"x30" High



300059 - Table, Starbase, 30" Diameter x 40" High



300058 - Table, Starbase, 40" Diameter x 30" High

Skirted Tables



3004 - Table 4', Skirted 4 Sides, 24" x 30" High



3006 - Table 6', Skirted 3 Sides, 24" x 30" High



3008 - Table 8', Skirted 3 Sides, 24" x 30" High

Table Skirt Colors



Beige (54)



Black (41)



Blue (42)

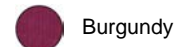

Burgundy (43)



Gold (46)



Gray (40)

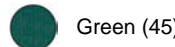

Green (45)

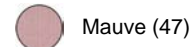

Mauve (47)



Purple (48)



Red (49)



Teal (55)

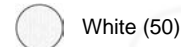

White (50)

Colors may vary due to facility lighting, printing limitations and dye lot differences. Some items may not be available at all locations. See order form for details. Styles of items portrayed on this brochure may vary in some locations.

Furniture and Accessories

Accessories



300124 - Aisle Stanchion Chain, Plastic, Per Foot



300123 - Aisle Stanchion, without Chain



300103 - Aluminum Easel



300111 - Bag Stand



300102 - Coat Rack



300104 - Garment Rack



300106 - Literature Rack



300201 - Pegboard, White, 4'x8'



300202 - Pegboard, White, 2'x8'



300107 - Refrigerator



300120 - Sign Holder, Bell Base



300108 - Sign Holder, Chrome, 22"x28"



300211 - Tackboard, 4'x8'



300112 - Ticket Tumbler, Small, Table Top



300113 - Wastebasket



300118 - Waterfall Stand

Colors may vary due to facility lighting, printing limitations and dye lot differences. Some items may not be available at all locations. See order form for details. Styles of items portrayed on this brochure may vary in some locations.

Furniture and Accessories Order Form

All orders are governed by the GES Payment Policy and GES Terms & Conditions of Contract as specified in this Exhibitor Services Manual.

Seattle International Auto Show
 CenturyLink Field Event Center
 November 10 - 13, 2016

Discount Deadline Date:
 October 21, 2016

Company Name _____ Email _____ Phone Number _____ Booth Number _____



Easy Ordering Tips:

- All prices include delivery, rental, and removal.
- Return your orders three (3) weeks before show move-in to ensure availability. At show site some items may not be available and substitutions might be necessary.
- Enjoy a fast and easy ordering experience online with Expresso:
<http://e.ges.com/061600445/furnishings/esm>

Furniture and Accessories

Skirt and Drape Color Options

(Gray will be provided if no color is indicated below)



Chairs

Item Code	Description	Discount (\$)	Regular (\$)	Qty	Tax %	Total
300051	Chair, Contemporary Arm, 23"W 18"D 31"H	88.00	132.25		9.6	\$
300052	Chair, Contemporary Side, 19.5"W 18"D 31"H	81.00	121.75		9.6	\$
300050	Chair, Plastic Contour, 18"W 18.5"D 32"H	46.50	69.75		9.6	\$
300053	Stool, Contemporary, 17"W 18"D 48"H	95.00	142.50		9.6	\$

Tables

Item Code	Description	Discount (\$)	Regular (\$)	Qty	Tax %	Total
300057	Table, Rectangle, 24"x36"x30" High	88.00	132.25		9.6	\$
300056	Table, Square, 24"x24"x30" High	81.00	121.75		9.6	\$
300059	Table, Starbase, 30" Diameter x 40" High	163.75	245.75		9.6	\$
300058	Table, Starbase, 40" Diameter x 30" High	163.75	245.75		9.6	\$

Skirted Tables

Item Code	Description	Color Code	Discount (\$)	Regular (\$)	Qty	Tax %	Total
3004	Table 4', Skirted 4 Sides, 24" x 30" High		95.00	142.50		9.6	\$
3006	Table 6', Skirted 3 Sides, 24" x 30" High		115.50	173.25		9.6	\$
3008	Table 8', Skirted 3 Sides, 24" x 30" High		136.25	204.25		9.6	\$
3003	Table Skirt Only		41.50	62.00		9.6	\$
3007	Table, Skirt 4th Side		53.50	80.25		9.6	\$
↳ Select size: 6' Table _____ 8' Table _____							

Unskirted Tables

Item Code	Description	Discount (\$)	Regular (\$)	Qty	Tax %	Total
300400	Table 4', Unskirted, 24" x 30" High	40.00	60.25		9.6	\$
300600	Table 6', Unskirted, 24" x 30" High	53.50	80.25		9.6	\$
300800	Table 8', Unskirted, 24" x 30" High	67.50	101.00		9.6	\$

Skirted Counters

Item Code	Description	Color Code	Discount (\$)	Regular (\$)	Qty	Tax %	Total
3014	Counter 4', Skirted 4 Sides, 24" x 42" High		108.75	162.75		9.6	\$
3016	Counter 6', Skirted 3 Sides, 24" x 42" High		129.50	194.50		9.6	\$
3018	Counter 8', Skirted 3 Sides, 24" x 42" High		149.75	224.75		9.6	\$

101116 061600445 A-1 100316

Form Continues on Next Page



Furniture and Accessories Order Form

All orders are governed by the GES Payment Policy and GES Terms & Conditions of Contract as specified in this Exhibitor Services Manual.

Discount Deadline Date:
October 21, 2016

Company Name	Email	Phone Number	Booth Number
3013	Counter Skirt Only	41.50	62.00 9.6 \$
3017	Counter, Skirt 4th Side	53.50	80.25 9.6 \$
↳ Select size: 6' Counter _____ 8' Counter _____			

Unskirted Counter

Item Code	Description	Discount (\$)	Regular (\$)	Qty	Tax %	Total
301400	Counter 4', Unskirted, 24" x 42" High	79.50	114.00		9.6	\$
301600	Counter 6', Unskirted, 24" x 42" High	90.50	136.25		9.6	\$
301800	Counter 8', Unskirted, 24" x 42" High	110.00	157.50		9.6	\$

Risers

Item Code	Description	Discount (\$)	Regular (\$)	Qty	Tax %	Total
300193	Riser 4', Double Tier, 48"x8"x16" High	46.50	69.75		9.6	\$
300191	Riser 4', Single Tier, 48"x8"x8" High	33.25	49.75		9.6	\$
300194	Riser 6', Double Tier, 72"x8"x16" High	60.50	90.75		9.6	\$
300192	Riser 6', Single Tier, 72"x8"x8" High	46.50	69.75		9.6	\$

Custom Booth Drape

Item Code	Description	Color Code	Discount (\$)	Regular (\$)	Qty	Tax %	Total
3001	Drape, 3' High, Per Foot, 4' Minimum		13.85	20.75		9.6	\$
3002	Drape, 8' High, Per Foot, 4' Minimum		16.70	25.25		9.6	\$
3019	Drape, 12' High, Per Foot		17.50	26.25		9.6	\$
3015	Drape, 16' High, Per Foot		18.95	28.25		9.6	\$

Accessories

Item Code	Description	Discount (\$)	Regular (\$)	Qty	Tax %	Total
300124	Aisle Stanchion Chain, Plastic, Per Foot	4.10	6.30		9.6	\$
300127	Aisle Stanchion, Tensa	40.00	60.25		9.6	\$
300123	Aisle Stanchion, without Chain	40.00	60.25		9.6	\$
300103	Aluminum Easel	53.50	80.25		9.6	\$
300111	Bag Stand	74.25	111.50		9.6	\$
300102	Coat Rack	74.25	111.50		9.6	\$
300104	Garment Rack	74.25	111.50		9.6	\$
300106	Literature Rack	96.75	145.00		9.6	\$
300201	Pegboard, White, 4'x8'	129.50	194.50		9.6	\$

↳ Select alignment: Horizontal _____ Vertical _____

300202	Pegboard, White, 2'x8'	96.50	144.75		9.6	\$
300107	Refrigerator	294.00	441.75		9.6	\$
300015	Rod, 6' to 10' Telescopic	16.70	25.75		9.6	\$
300131	Security Cage, Large, without Lock	411.50	617.25		9.6	\$
300132	Security Cage, Small, without Lock	273.75	410.75		9.6	\$
300120	Sign Holder, Bell Base	67.50	101.00		9.6	\$
300108	Sign Holder, Chrome, 22"x28"	67.50	101.00		9.6	\$
300211	Tackboard, 4'x8'	136.25	204.25		9.6	\$

↳ Select alignment: Horizontal _____ Vertical _____

300112	Ticket Tumbler, Small, Table Top	115.50	173.25		9.6	\$
--------	----------------------------------	--------	--------	--	-----	----

A-1 100316 101116 061600445



Furniture and Accessories Order Form

All orders are governed by the GES Payment Policy and GES Terms & Conditions of Contract as specified in this Exhibitor Services Manual.

Discount Deadline Date:
October 21, 2016

Company Name _____ Email _____ Phone Number _____ Booth Number _____

Accessories

300113	Wastebasket	16.70	25.25		9.6	\$
300118	Waterfall Stand	74.25	111.50		9.6	\$

Electrical Outlets Not Included

Need power for that lamp or refrigerator in your booth? Order electrical outlets separately for your booth space through the electrical service provider.

Total and Sign: Return to Fax: 866.329.1437 • International Fax: 702.263.1520

Please Sign

X

Authorized Signature

Authorized Name - Please Print

Date

I agree in placing this order that I have accepted GES Payment Policy and GES Terms & Conditions of Contract, including authorization for GES to retain personal information to better serve my need for GES services at future events.

Total Payment Enclosed

\$

Cancellation Policy: Items cancelled will be charged **50%** of original price after move-in begins and **100%** of original price after installation.

101116 061600445

A-1 100316



Furniture Package Order Form

All orders are governed by the GES Payment Policy and GES Terms & Conditions of Contract as specified in this Exhibitor Services Manual.

Seattle International Auto Show
 CenturyLink Field Event Center
 November 10 - 13, 2016

Discount Deadline Date:
 October 21, 2016

Company Name _____ Email _____ Phone Number _____ Booth Number _____



Easy Ordering Tips:

- Furniture Packages offer significant savings and convenience.
- All prices include delivery, rental, and removal.
- Return your orders three (3) weeks before show move-in to ensure availability. At show site some items may not be available and substitutions might be necessary.

Furniture Package



Furniture Package 1

Item Code	Description	Color Code	Discount (\$)	Regular (\$)	Qty	Tax %	Total
4906	Furniture Package 1		202.68	304.20		9.6	\$
↳ Includes 10% Off: (2) Plastic Contour Chairs, (1) 6' Skirted Table 24"X30", (1) Wastebasket.							

Skirt Color Options

(Gray will be provided if no color is indicated.)

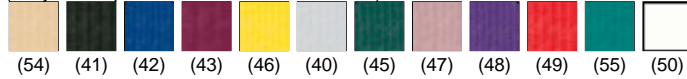

Furniture Package 2

Item Code	Description	Discount (\$)	Regular (\$)	Qty	Tax %	Total
490012	Furniture Package 2	479.21	720.00		9.6	\$
↳ Includes 10% Off: (4) Contemporary Arm Chairs, (1) Starbase Table 40"X30", (1) Wastebasket.						

Total and Sign: Return to Fax: 866.329.1437 • International Fax: 702.263.1520

Please Sign

X

Authorized Signature

Authorized Name - Please Print

Date

I agree in placing this order that I have accepted GES Payment Policy and GES Terms & Conditions of Contract, including authorization for GES to retain personal information to better serve my need for GES services at future events.

Total Payment Enclosed

\$

Cancellation Policy: Items cancelled will be charged **50%** of original price after move-in begins and **100%** of original price after installation.

061600445

101116

A-2 071916



Specialty Furniture

Seating - Sofas and Loveseats



305321 - Key Largo Loveseat, Black Fabric, 57"L 35"D 34"H



305322 - Key Largo Sofa, Black Fabric, 79"L 35"D 34"H



305262 - Loveseat, Naples, Black Vinyl, 62"L 30"D 28"H



305364 - Naples Loveseat, Powered Black Vinyl, 62"L 30"D 28"H



305362 - Naples Sofa, Powered Black Vinyl, 87"L 30"D 28"H



305217 - Roma Sofa, Powered White Vinyl, 78"L 31"D 33"H



305264 - Sectional, Heathrow, Black Vinyl, 72"L 48"D 28"H



305120 - Sectional, South Beach, 3 pc., Platinum, 152"L 40"D 33"H



305236 - Sofa, Allegro, Blue Fabric, 73"L 34.5"D 29.5"H



305265 - Sofa, Heathrow, Black Vinyl, 48"L 24"D 28"H



305261 - Sofa, Naples, Black Vinyl, 87"L 30"D 28"H



305221 - Sofa, Roma, White Vinyl, 78"L 31"D 33"H



305119 - Sofa, South Beach, Platinum Suede, 69"L 29"D 33"H



305268 - Sofa, Tangiers, 78"L 37"D 36"H

Colors may vary due to facility lighting, printing limitations and dye lot differences. Some items may not be available at all locations. See order form for details. Styles of items portrayed on this brochure may vary in some locations.

Specialty Furniture

Seating - Club Chairs



305235 - Chair, Allegro, Blue Fabric, 36\"/>



305072 - Chair, Barcelona, Black, 30\"/>



305073 - Chair, Barcelona, White, 30\"/>



305266 - Chair, Heathrow, Black Vinyl, 24\"/>



305263 - Chair, Naples, Black Vinyl, 36\"/>



305220 - Chair, Roma, White Vinyl, 37\"/>



305269 - Chair, Tangiers, 34\"/>



305070 - Chair, Tub, Key West, Black, 31\"/>



305267 - Corner, Heathrow, Black Vinyl, 24\"/>



305320 - Key Largo Chair, Black Fabric, 35\"/>



305363 - Naples Chair, Powered Black Vinyl, 36\"/>



305222 - Roma Chair, Powered White Vinyl, 37\"/>

Seating - Chairs



305152 - Chair, Altura, Guest, 25\"/>



305041 - Chair, Berlin, Black/White, 18\"/>



305042 - Chair, Berlin, Red/White, 18\"/>



305110 - Chair, Brewer, Black, 20\"/>



305260 - Chair, Christopher, White Vinyl w/Chrome, 17\"/>



305285 - Chair, Duet Stack, Black/Chrome, 23\"/>



305231 - Chair, Fusion, Clear/White, 19\"/>



305230 - Chair, Fusion, Green/White, 19\"/>



305232 - Chair, Fusion, Red/White, 18\"/>



305079 - Chair, Ice Transparent/Chrome, 17.25\"/>



305034 - Chair, Iso Mesh Black, 36\"/>



305111 - Chair, Jetson, 19\"/>



305271 - Chair, La Brea Swivel, Charcoal Gray Fabric, 35\"/>



305149 - Chair, Luxor, Guest, 27\"/>



305270 - Chair, Madden Arm, Lt. Gray Vinyl, 27\"/>



305108 - Chair, New York, 23\"/>



305284 - Chair, Rustique Arm, Gunmetal, 20\"/>



305272 - Chair, Swanson Swivel, White Vinyl, 28\"/>



305250 - Chair, Wendy, Clear Acrylic, 15\"/>

Colors may vary due to facility lighting, printing limitations and dye lot differences. Some items may not be available at all locations. See order form for details. Styles of items portrayed on this brochure may vary in some locations.

Specialty Furniture

Seating - Ottomans



305096 - Endless Curved Ottoman, Black, 60.5"L 37.5"D 15"H



305097 - Endless Curved Ottoman, White, 60.5"L 37.5"D 15"H



305277 - Ottoman, Bench, Black Vinyl, 60"L 20"D 18"H



305278 - Ottoman, Bench, White Vinyl, 60"L 20"D 18"H



305085 - Ottoman, Cube, Black, 17"L 17"D 18"H



305093 - Ottoman, Cube, White Leather, 17"L 17"D 18"H



305092 - Ottoman, South Beach, Wedge, Platinum, 25"L 31"D 18"H



305280 - Ottoman, Square Seat, Black, 34"L 34"D 15"H



305279 - Ottoman, Square Seat, White, 34"L 34"D 15"H



305246 - Ottoman, Vibe Cube, Blue, Vinyl, 18"L 18"D 18"H



305242 - Ottoman, Vibe Cube, Champagne, Vinyl, 18"L 18"D 18"H



305243 - Ottoman, Vibe Cube, Gold/Bronze, Vinyl, 18"L 18"D 18"H



305241 - Ottoman, Vibe Cube, Green, Vinyl, 18"L 18"D 18"H



305244 - Ottoman, Vibe Cube, Pink, Vinyl, 18"L 18"D 18"H



305245 - Ottoman, Vibe Cube, Red, Vinyl, 18"L 18"D 18"H



305247 - Ottoman, Vibe Cube, Yellow, Vinyl, 18"L 18"D 18"H

Seating - Office and Utility Seating



305126 - Chair, Altura Task, 25"L 26"D 21"H



305150 - Chair, Altura, High Back, 25"L 25"D 43"H Adj.



305151 - Chair, Altura, Med. Back, 25"L 25"D 37"H Adj.



305305 - Chair, Executive, Pro, White, 27.5"L 27.5"D 45.7"H



305147 - Chair, Luxor, High Back, 27"L 28"D 47"H Adj.



305148 - Chair, Luxor, Med. Back, 27"L 28"D 41"H Adj.



305309 - Meeting Chair, White Vinyl, 25.5"L 23.5"D 34"H



305307 - Pro Executive Mid Back Chair, Black Vinyl, 24"L 22"D 40"H



305308 - Pro Executive Mid Back Chair, White, 24"L 22"D 40"H



305043 - Stool, Drafting, 25"L 26"D 34"H

Colors may vary due to facility lighting, printing limitations and dye lot differences. Some items may not be available at all locations. See order form for details. Styles of items portrayed on this brochure may vary in some locations.

Specialty Furniture

Seating - Barstools



305370 - Apex Barstool, Black Vinyl, 21"L 21"D 33"H



305371 - Apex Barstool, Blue Ultra Suede, 21"L 21"D 33"H



305372 - Apex Barstool, Red Vinyl, 21"L 21"D 33"H



305373 - Apex Barstool, White Vinyl, 21"L 21"D 33"H



305012 - Barstool, Banana, Black, 21"L 22"D 30"H



305013 - Barstool, Banana, White, 21"L 22"D 30"H



305010 - Barstool, Gin, Maple, 16"L 16"D 29"H



305023 - Barstool, Ice, Transparent/Chrome, 16.75"L 16"D 32"H



305011 - Barstool, Jetson, Black, 18"L 19"D 29"H



305289 - Barstool, Lift, Chrome/Black Seat, 15" Round 23-33.5"H



305292 - Barstool, Lift, Chrome/Gray Seat, 15" Round 23-33.5"H



305291 - Barstool, Lift, Chrome/Red Seat, 15" Round 23-33.5"H



305290 - Barstool, Lift, Chrome/White Seat, 15" Round 23-33.5"H



305009 - Barstool, Oslo, Blue, 17"L 20"D 30"H



305008 - Barstool, Oslo, White, 17"L 20"D 30"H



305288 - Barstool, Rustique, Gunmetal, 13"L 13"D 30"D



305206 - Barstool, Shark Swivel, White/Chrome Base, 22"L 19"D 34"-44"H



305207 - Barstool, Zooey Swivel, White/Chrome Base, 15"Lx17"Dx31"-35"H



305259 - Christopher Barstool, 19"L 15"D 41"H

Table Surface Colors



Maple



Graphite Nebula



Brushed Red



Brushed Blue

Tables - Cafe



305315 - 30" Round Café Table w/ Hydraulic Base, Mahogany Top, 30"RND 29"H



305318 - 30" Round Café Table w/ Hydraulic Base, Orange Top, 30"RND 29"H



305067 - G30 Cafe Table, Powered White Top, 72"L 26"D 30"H



305162 - Table, Cafe, Blue/Black, 30" Round 29"H



305154 - Table, Cafe, Blue/ Hydraulic Base, 30" Round 29"H



305164 - Table, Cafe, Graphite/Black, 30" Round 29"H



305167 - Table, Cafe, Graphite/Black, 36" Round 29"H



305156 - Table, Cafe, Graphite/ Hydraulic Base, 30" Round 29"H

Colors may vary due to facility lighting, printing limitations and dye lot differences. Some items may not be available at all locations. See order form for details. Styles of items portrayed on this brochure may vary in some locations.

Specialty Furniture



305159 - Table, Cafe, Graphite/ Hydraulic Base, 36" Round 29"H



305165 - Table, Cafe, Maple/ Black, 30" Round 29"H



305168 - Table, Cafe, Maple/ Black, 36" Round 29"H



305157 - Table, Cafe, Maple/ Hydraulic Base, 30" Round 29"H



305160 - Table, Cafe, Maple/ Hydraulic Base, 36" Round 29"H



305161 - Table, Cafe, Red/ Black, 30" Round 29"H



305153 - Table, Cafe, Red/ Hydraulic Base, 30" Round 29"H



305282 - Table, Cafe, Silver Texture/Black Base, 30" Round 29"H



305299 - Table, Cafe, Silver Textured Grain/ Hydraulic Base, 30" Round 29"H



305283 - Table, Cafe, White Laminate/Black Base, 36" Round 29"H



305301 - Table, Cafe, White Laminate/ Hydraulic Base, 36" Round 29"H

Tables - Bar



305316 - 30" Round Bar Table w/ Hydraulic Base, Mahogany Top, 30" RND 45"H



305317 - 30" Round Bar Table w/ Hydraulic Base, Orange Top, 30" RND 45"H



305071 - G30 Bar Table, Powered White Top, 72"L 26"D 42"H



305131 - Table, Bar, Blue/Black, 30" Round 42"H



305140 - Table, Bar, Blue/ Hydraulic Base, 30" Round 42"H



305133 - Table, Bar, Graphite/ Black, 30" Round 42"H



305136 - Table, Bar, Graphite/ Black, 36" Round 42"H



305142 - Table, Bar, Graphite/ Hydraulic Base, 30" Round 42"H



305145 - Table, Bar, Graphite/ Hydraulic Base, 36" Round 42"H



305134 - Table, Bar, Maple/Black, 30" Round 42"H



305137 - Table, Bar, Maple/Black, 36" Round 42"H



305143 - Table, Bar, Maple/ Hydraulic Base, 30" Round 42"H



305146 - Table, Bar, Maple/ Hydraulic Base, 36" Round 42"H



305130 - Table, Bar, Red/Black, 30" Round 42"H



305139 - Table, Bar, Red/ Hydraulic Base, 30" Round 42"H



305286 - Table, Bar, Silver Textured Grain/ Black Base, 30" Round 42"H



305302 - Table, Bar, Silver Textured Grain/ Hydraulic Base, 30" Round 42"H



305287 - Table, Bar, White Laminate/Black Base, 36" Round 42"H



305303 - Table, Bar, White Laminate/ Hydraulic Base, 36" Round 42"H

Colors may vary due to facility lighting, printing limitations and dye lot differences. Some items may not be available at all locations. See order form for details. Styles of items portrayed on this brochure may vary in some locations.

Specialty Furniture

Tables - Cocktail



305189 - G30 Cocktail Table, Powered White Top, 72"L 26"D 18"H



305188 - Sydney Powered Cocktail Table, Black, 48"L 26"D 18"H



305187 - Sydney Powered Cocktail Table, White, 48"L 26"D 18"H



305017 - Table, Cocktail, Geo, Black, 50"L 22"D 16"H



305014 - Table, Cocktail, Geo, Chrome, 50"L 22"D 16"H



305020 - Table, Cocktail, Inspiration, 42"L 28"D 18"H



305210 - Table, Cocktail, Oliver, 47"L 27"D 19"H



305016 - Table, Cocktail, Silverado, 36" Round 17"H



305025 - Table, Cocktail, Sydney Black, 48"L 26"D 18"H



305024 - Table, Cocktail, Sydney White, 48"L 26"D 18"H

Tables - End Tables



305112 - Regis End Table, 16"L 15.5"D 16.5"H



305273 - Table, Aura, White Metal, 15" Round 22"H



305274 - Table, E, Wood, 21"L 15.5"D 27.5"H



305047 - Table, End, Geo, Black, 26"L 26"D 20"H



305044 - Table, End, Geo, Chrome, 26"L 26"D 20"H



305049 - Table, End, Inspiration, 24"L 28"D 22"H



305211 - Table, End, Oliver, 22" Round 22"H



305046 - Table, End, Silverado, 24" Round 22"H



305050 - Table, End, Sydney, Black, 27"L 23"D 22"H



305048 - Table, End, Sydney, White, 27"L 23"D 22"H



305276 - Table, Mosaic, Set of 3



305275 - Table, Timber, Wood, 16" Round 17"H

Colors may vary due to facility lighting, printing limitations and dye lot differences. Some items may not be available at all locations. See order form for details. Styles of items portrayed on this brochure may vary in some locations.

Specialty Furniture

Conference Tables



305190 - Powered Conference Table Module, Black, 5"L 2.25"D 2"H



305175 - Table, Conf., Geo, Black, 42"L 42"D 29"H



305176 - Table, Conf., Geo, Black, 60"L 36"D 29"H



305173 - Table, Conf., Geo, Chrome, 42"L 42"D 29"H



305174 - Table, Conf., Geo, Chrome, 60"L 36"D 29"H



305027 - Table, Conf., Graphite, 42" Round 29"H



305028 - Table, Conf., Graphite, 72"L 42"D 29"H



305029 - Table, Conf., Graphite, 96"L 48"D 29"H



305033 - Table, Conf., Mahogany, 120"L 42"W 29"H



305030 - Table, Conf., Mahogany, 42" Round, 42"L 42"W 29"H



305031 - Table, Conf., Mahogany, 72"L 42"W 29"H



305032 - Table, Conf., Mahogany, 96"L 42"W 29"H



305177 - Table, Conf., Manhattan, 42" Round 29"H



305293 - Table, Conf., Merlin, Gray Laminate/Black, 46"L 29"D 30"H



305281 - Table, Conf., White Laminate, 42" Round 29"H



305208 - Table, Nova, Oval, White/Silver Legs, 71"L 35.5"D 29"H

Colors may vary due to facility lighting, printing limitations and dye lot differences. Some items may not be available at all locations. See order form for details. Styles of items portrayed on this brochure may vary in some locations.

Specialty Furniture

Tables - Martini Bar



305004 - Table, Bar, Martini 3 pc., 100"L 100"D 47"H



305003 - Table, Bar, Martini, 50"L 50"D 47"H

Product Display



305001 - Bookcase, Mahogany, 36"L 13"D 71"H



305053 - Etagere, Black, 30"L 16"D 70"H



305052 - Etagere, Pewter, 30"L 16"D 70"H



305103 - Pedestal, Locking Door, Black, 24"L 24"D 42"H



305297 - Pedestal, Powered Locking, Black, 24"L 24"D 30"H



305295 - Pedestal, Powered Locking, Black, 24"L 24"D 42"H



305298 - Pedestal, Powered Locking, White, 24"L 24"D 30"H



305296 - Pedestal, Powered Locking, White, 24"L 24"D 42"H

Office and Utility Furniture



305039 - Credenza, Mahogany, 72"L 24"D 29"H



305056 - Desk, Executive, Mahogany, 60"L 30"D 29"H



305294 - Desk, Writing/Work Table, White Laminate/White, 48"L 24"D 30"H



305058 - File, Lateral, Mahogany, 36"L 20"D 29"H

Colors may vary due to facility lighting, printing limitations and dye lot differences. Some items may not be available at all locations. See order form for details. Styles of items portrayed on this brochure may vary in some locations.

Specialty Furniture

Lamps



305204 - Lamp, Floor,
Mason, Silver, 18" Round
55"H



305205 - Lamp, Table,
Mason, Silver, 16" Round
26"H

Accessories



305380 - Charging
Adapter, Black, 33"L



305381 - Charging
Adapter, White, 33"L

Colors may vary due to facility lighting, printing limitations and dye lot differences. Some items may not be available at all locations. See order form for details. Styles of items portrayed on this brochure may vary in some locations.

Specialty Furniture Order Form

All orders are governed by the GES Payment Policy and GES Terms & Conditions of Contract as specified in this Exhibitor Services Manual.

Seattle International Auto Show
CenturyLink Field Event Center
November 10 - 13, 2016

Discount Deadline Date:
October 21, 2016

Company Name _____ Email _____ Phone Number _____ Booth Number _____



Easy Ordering Tips:

- All prices include delivery, rental, and removal.
- Return your orders three (3) weeks before show move-in to ensure availability. At show site some items may not be available and substitutions might be necessary.
- Enjoy a fast and easy ordering experience online with Expresso:
<http://e.ges.com/061600445/furnishings/esm>

Specialty Furniture

Link to view images: <http://ges.com/ecomm/info/B1-Brochure-CORE.pdf>

Seating - Sofas and Loveseats

Item Code	Description	Discount (\$)	Regular (\$)	Qty	Tax %	Total
305321	Key Largo Loveseat, Black Fabric, 57"L 35"D 34"H	709.00	1,060.00		9.6	\$
305322	Key Largo Sofa, Black Fabric, 79"L 35"D 34"H	768.00	1,150.00		9.6	\$
305262	Loveseat, Naples, Black Vinyl, 62"L 30"D 28"H	427.00	641.00		9.6	\$
305364	Naples Loveseat, Powered Black Vinyl, 62"L 30"D 28"H	1,540.00	2,310.00		9.6	\$
305362	Naples Sofa, Powered Black Vinyl, 87"L 30"D 28"H	1,770.00	2,660.00		9.6	\$
305217	Roma Sofa, Powered White Vinyl, 78"L 31"D 33"H	1,770.00	2,660.00		9.6	\$
305264	Sectional, Heathrow, Black Vinyl, 72"L 48"D 28"H	1,215.00	1,820.00		9.6	\$
305120	Sectional, South Beach, 3 pc., Platinum, 152"L 40"D 33"H	1,213.75	1,821.25		9.6	\$
305236	Sofa, Allegro, Blue Fabric, 73"L 34.5"D 29.5"H	697.25	1,050.50		9.6	\$
305265	Sofa, Heathrow, Black Vinyl, 48"L 24"D 28"H	497.00	746.00		9.6	\$
305261	Sofa, Naples, Black Vinyl, 87"L 30"D 28"H	536.00	804.00		9.6	\$
305221	Sofa, Roma, White Vinyl, 78"L 31"D 33"H	894.00	1,339.00		9.6	\$
305119	Sofa, South Beach, Platinum Suede, 69"L 29"D 33"H	551.50	827.75		9.6	\$
305268	Sofa, Tangiers, 78"L 37"D 36"H	458.00	687.00		9.6	\$

Seating - Club Chairs

Item Code	Description	Discount (\$)	Regular (\$)	Qty	Tax %	Total
305235	Chair, Allegro, Blue Fabric, 36"L 34.5"D 29.5"H	552.00	828.00		9.6	\$
305072	Chair, Barcelona, Black, 30"L 31"D 35"H	672.25	1,007.75		9.6	\$
305073	Chair, Barcelona, White, 30"L 30"D 31"H	672.25	1,007.75		9.6	\$
305266	Chair, Heathrow, Black Vinyl, 24"L 24"D 28"H	276.00	414.00		9.6	\$
305263	Chair, Naples, Black Vinyl, 36"L 30"D 28"H	356.00	534.00		9.6	\$
305220	Chair, Roma, White Vinyl, 37"L 31"D 33"H	553.00	830.25		9.6	\$
305269	Chair, Tangiers, 34"L 37"D 36"H	321.00	482.00		9.6	\$
305070	Chair, Tub, Key West, Black, 31"L 31"D 31"H	325.00	486.50		9.6	\$
305267	Corner, Heathrow, Black Vinyl, 24"L 24"D 28"H	344.00	516.00		9.6	\$
305320	Key Largo Chair, Black Fabric, 35"L 35"D 34"H	621.00	932.00		9.6	\$
305363	Naples Chair, Powered Black Vinyl, 36"L 30"D 28"H	1,150.00	1,730.00		9.6	\$
305222	Roma Chair, Powered White Vinyl, 37"L 31"D 33"H	1,150.00	1,730.00		9.6	\$

Seating - Chairs

Item Code	Description	Discount (\$)	Regular (\$)	Qty	Tax %	Total
305152	Chair, Altura, Guest, 25"L 20"D 34"H	255.50	383.50		9.6	\$

101116 061600445 B-1 051016



Specialty Furniture Order Form

All orders are governed by the GES Payment Policy and GES Terms & Conditions of Contract as specified in this Exhibitor Services Manual.

Discount Deadline Date:
October 21, 2016

Company Name _____ Email _____ Phone Number _____

Seating - Chairs						
305041	Chair, Berlin, Black/White, 18"L 22"D 32"H	110.25	165.75		9.6	\$
305042	Chair, Berlin, Red/White, 18"L 22"D 32"H	110.25	165.75		9.6	\$
305110	Chair, Brewer, Black, 20"L 20"D 32"H	127.50	191.25		9.6	\$
305260	Chair, Christopher, White Vinyl w/Chrome, 17"L 19"D 35"H	109.00	164.00		9.6	\$
305285	Chair, Duet Stack, Black/Chrome, 23"L 18.5"D 16"H	73.00	110.00		9.6	\$
305231	Chair, Fusion, Clear/White, 19"L 21"D 32"H	151.50	227.75		9.6	\$
305230	Chair, Fusion, Green/White, 19"L 21"D 32"H	151.50	227.75		9.6	\$
305232	Chair, Fusion, Red/White, 19"L 21"D 32"H	151.50	227.75		9.6	\$
305079	Chair, Ice Transparent/Chrome, 17.25"L 20"D 32"H	197.75	297.50		9.6	\$
305034	Chair, Iso Mesh Black, 36"L 24"D 38"H	267.50	401.25		9.6	\$
305111	Chair, Jetson, 19"L 18"D 31"H	169.50	254.00		9.6	\$
305271	Chair, La Brea Swivel, Charcoal Gray Fabric, 35"L 27"D 40"D	361.00	542.00		9.6	\$
305149	Chair, Luxor, Guest, 27"L 28"D 40"H	281.50	422.25		9.6	\$
305270	Chair, Madden Arm, Lt. Gray Vinyl, 27"L 32"D 33"H	373.00	560.00		9.6	\$
305108	Chair, New York, 23"L 32"D 33"H	173.75	261.00		9.6	\$
305284	Chair, Rustique Arm, Gunmetal, 20"L 18"D 31"H	151.00	227.00		9.6	\$
305272	Chair, Swanson Swivel, White Vinyl, 28"L 25"D 18"H	230.00	345.00		9.6	\$
305250	Chair, Wendy, Clear Acrylic, 15"L 20"D 36"H	109.00	164.00		9.6	\$

Seating - Ottomans						
Item Code	Description	Discount (\$)	Regular (\$)	Qty	Tax %	Total
305096	Endless Curved Ottoman, Black, 60.5"L 37.5"D 15"H	522.00	783.00		9.6	\$
305097	Endless Curved Ottoman, White, 60.5"L 37.5"D 15"H	522.00	783.00		9.6	\$
305277	Ottoman, Bench, Black Vinyl, 60"L 20"D 18"H	312.00	468.00		9.6	\$
305278	Ottoman, Bench, White Vinyl, 60"L 20"D 18"H	312.00	468.00		9.6	\$
305085	Ottoman, Cube, Black, 17"L 17"D 18"H	92.25	138.50		9.6	\$
305093	Ottoman, Cube, White Leather, 17"L 17"D 18"H	92.25	138.50		9.6	\$
305092	Ottoman, South Beach, Wedge, Platinum, 25"L 31"D 18"H	211.25	316.75		9.6	\$
305280	Ottoman, Square Seat, Black, 34"L 34"D 15"H	94.00	141.00		9.6	\$
305279	Ottoman, Square Seat, White, 34"L 34"D 15"H	94.00	141.00		9.6	\$
305246	Ottoman, Vibe Cube, Blue, Vinyl, 18"L 18"D 18"H	125.75	188.50		9.6	\$
305242	Ottoman, Vibe Cube, Champagne, Vinyl, 18"L 18"D 18"H	125.75	188.50		9.6	\$
305243	Ottoman, Vibe Cube, Gold/Bronze, Vinyl, 18"L 18"D 18"H	125.75	188.50		9.6	\$
305241	Ottoman, Vibe Cube, Green, Vinyl, 18"L 18"D 18"H	125.75	188.50		9.6	\$
305244	Ottoman, Vibe Cube, Pink, Vinyl, 18"L 18"D 18"H	125.75	188.50		9.6	\$
305245	Ottoman, Vibe Cube, Red, Vinyl, 18"L 18"D 18"H	125.75	188.50		9.6	\$
305247	Ottoman, Vibe Cube, Yellow, Vinyl, 18"L 18"D 18"H	125.75	188.50		9.6	\$

Seating - Office and Utility Seating						
Item Code	Description	Discount (\$)	Regular (\$)	Qty	Tax %	Total
305126	Chair, Altura Task, 25"L 26"D 21"H	125.50	188.00		9.6	\$
305150	Chair, Altura, High Back, 25"L 25"D 43"H Adj.	309.50	464.75		9.6	\$
305151	Chair, Altura, Med. Back, 25"L 25"D 37"H Adj.	296.50	443.75		9.6	\$

101116 061600445
B-1 051016



Specialty Furniture Order Form

All orders are governed by the GES Payment Policy and GES Terms & Conditions of Contract as specified in this Exhibitor Services Manual.

Discount Deadline Date:
October 21, 2016

Company Name _____ Email _____ Phone Number _____

Seating - Office and Utility Seating						
305305	Chair, Executive, Pro, White, 27.5"L 27.5"D 45.7"H	250.00	375.00		9.6	\$
305147	Chair, Luxor, High Back, 27"L 28"D 47"H Adj.	348.00	522.00		9.6	\$
305148	Chair, Luxor, Med. Back, 27"L 28"D 41"H Adj.	317.00	475.25		9.6	\$
305309	Meeting Chair, White Vinyl, 25.5"L 23.5"D 34"H	357.00	536.00		9.6	\$
305307	Pro Executive Mid Back Chair, Black Vinyl, 24"L 22"D 40"H	694.00	1,040.00		9.6	\$
305308	Pro Executive Mid Back Chair, White, 24"L 22"D 40"H	516.00	774.00		9.6	\$
305043	Stool, Drafting, 25"L 26"D 34"H	182.25	273.75		9.6	\$

Seating - Barstools						
Item Code	Description	Discount (\$)	Regular (\$)	Qty	Tax %	Total
305370	Apex Barstool, Black Vinyl, 21"L 21"D 33"H	375.00	563.00		9.6	\$
305371	Apex Barstool, Blue Ultra Suede, 21"L 21"D 33"H	375.00	563.00		9.6	\$
305372	Apex Barstool, Red Vinyl, 21"L 21"D 33"H	375.00	563.00		9.6	\$
305373	Apex Barstool, White Vinyl, 21"L 21"D 33"H	375.00	563.00		9.6	\$
305012	Barstool, Banana, Black, 21"L 22"D 30"H	136.75	205.25		9.6	\$
305013	Barstool, Banana, White, 21"L 22"D 30"H	136.75	205.25		9.6	\$
305010	Barstool, Gin, Maple, 16"L 16"D 29"H	176.25	264.25		9.6	\$
305023	Barstool, Ice, Transparent/Chrome, 16.75"L 16"D 32"H	197.25	296.75		9.6	\$
305011	Barstool, Jetson, Black, 18"L 19"D 29"H	225.75	338.50		9.6	\$
305289	Barstool, Lift, Chrome/Black Seat, 15" Round 23-33.5"H	104.00	156.00		9.6	\$
305292	Barstool, Lift, Chrome/Gray Seat, 15" Round 23-33.5"H	104.00	156.00		9.6	\$
305291	Barstool, Lift, Chrome/Red Seat, 15" Round 23-33.5"H	104.00	156.00		9.6	\$
305290	Barstool, Lift, Chrome/White Seat, 15" Round 23-33.5"H	104.00	156.00		9.6	\$
305009	Barstool, Oslo, Blue, 17"L 20"D 30"H	249.75	374.75		9.6	\$
305008	Barstool, Oslo, White, 17"L 20"D 30"H	249.75	374.75		9.6	\$
305288	Barstool, Rustique, Gunmetal, 13"L 13"D 30"D	133.00	200.00		9.6	\$
305206	Barstool, Shark Swivel, White/Chrome Base, 22"L 19"D 34"- 44"H	380.00	570.00		9.6	\$
305207	Barstool, Zooey Swivel, White/Chrome Base, 15"Lx17"Dx31"-35"H	363.50	546.00		9.6	\$
305259	Christopher Barstool, 19"L 15"D 41"H	367.00	551.00		9.6	\$

Tables - Cafe						
Item Code	Description	Discount (\$)	Regular (\$)	Qty	Tax %	Total
305315	30" Round Café Table w/ Hydraulic Base, Mahogany Top, 30"RN	451.00	677.00		9.6	\$
305318	30" Round Café Table w/ Hydraulic Base, Orange Top, 30"RND 2	451.00	677.00		9.6	\$
305067	G30 Cafe Table, Powered White Top, 72"L 26"D 30"H	1,680.00	2,520.00		9.6	\$
305162	Table, Cafe, Blue/Black, 30" Round 29"H	191.50	288.25		9.6	\$
305154	Table, Cafe, Blue/Hydraulic Base, 30" Round 29"H	256.25	384.25		9.6	\$
305164	Table, Cafe, Graphite/Black, 30" Round 29"H	191.50	288.25		9.6	\$
305167	Table, Cafe, Graphite/Black, 36" Round 29"H	224.00	336.25		9.6	\$
305156	Table, Cafe, Graphite/Hydraulic Base, 30" Round 29"H	256.25	384.25		9.6	\$
305159	Table, Cafe, Graphite/Hydraulic Base, 36" Round 29"H	303.50	456.25		9.6	\$
305165	Table, Cafe, Maple/Black, 30" Round 29"H	191.50	288.25		9.6	\$
305168	Table, Cafe, Maple/Black, 36" Round 29"H	224.00	336.25		9.6	\$

B-1 051016 101116 061600445



Specialty Furniture Order Form

All orders are governed by the GES Payment Policy and GES Terms & Conditions of Contract as specified in this Exhibitor Services Manual.

Discount Deadline Date:
October 21, 2016

Company Name _____ Email _____ Phone Number _____

Tables - Cafe						
305157	Table, Cafe, Maple/Hydraulic Base, 30" Round 29"H	256.25	384.25		9.6	\$
305160	Table, Cafe, Maple/Hydraulic Base, 36" Round 29"H	303.50	456.25		9.6	\$
305161	Table, Cafe, Red/Black, 30" Round 29"H	191.50	288.25		9.6	\$
305153	Table, Cafe, Red/Hydraulic Base, 30" Round 29"H	256.25	384.25		9.6	\$
305282	Table, Cafe, Silver Texture/Black Base, 30" Round 29"H	164.00	246.00		9.6	\$
305299	Table, Cafe, Silver Textured Grain/Hydraulic Base, 30" Round 29"	206.00	309.00		9.6	\$
305283	Table, Cafe, White Laminate/Black Base, 36" Round 29"H	148.00	222.00		9.6	\$
305301	Table, Cafe, White Laminate/Hydraulic Base, 36" Round 29"H	202.00	303.00		9.6	\$

Tables - Bar						
Item Code	Description	Discount (\$)	Regular (\$)	Qty	Tax %	Total
305316	30" Round Bar Table w/ Hydraulic Base, Mahogany Top, 30"RND	451.00	677.00		9.6	\$
305317	30" Round Bar Table w/ Hydraulic Base, Orange Top, 30"RND 45	451.00	677.00		9.6	\$
305071	G30 Bar Table, Powered White Top, 72"L 26"D 42"H	2,200.00	3,300.00		9.6	\$
305131	Table, Bar, Blue/Black, 30" Round 42"H	199.75	299.50		9.6	\$
305140	Table, Bar, Blue/Hydraulic Base, 30" Round 42"H	261.00	391.00		9.6	\$
305133	Table, Bar, Graphite/Black, 30" Round 42"H	199.75	299.50		9.6	\$
305136	Table, Bar, Graphite/Black, 36" Round 42"H	245.75	368.25		9.6	\$
305142	Table, Bar, Graphite/Hydraulic Base, 30" Round 42"H	261.00	391.00		9.6	\$
305145	Table, Bar, Graphite/Hydraulic Base, 36" Round 42"H	307.50	460.75		9.6	\$
305134	Table, Bar, Maple/Black, 30" Round 42"H	199.75	299.50		9.6	\$
305137	Table, Bar, Maple/Black, 36" Round 42"H	245.75	368.25		9.6	\$
305143	Table, Bar, Maple/Hydraulic Base, 30" Round 42"H	261.00	391.00		9.6	\$
305146	Table, Bar, Maple/Hydraulic Base, 36" Round 42"H	307.50	460.75		9.6	\$
305130	Table, Bar, Red/Black, 30" Round 42"H	199.75	299.50		9.6	\$
305139	Table, Bar, Red/Hydraulic Base, 30" Round 42"H	261.00	391.00		9.6	\$
305286	Table, Bar, Silver Textured Grain/Black Base, 30" Round 42"H	179.00	269.00		9.6	\$
305302	Table, Bar, Silver Textured Grain/Hydraulic Base, 30" Round 42"H	219.00	329.00		9.6	\$
305287	Table, Bar, White Laminate/Black Base, 36" Round 42"H	167.00	251.00		9.6	\$
305303	Table, Bar, White Laminate/Hydraulic Base, 36" Round 42"H	212.00	318.00		9.6	\$

Tables - Cocktail						
Item Code	Description	Discount (\$)	Regular (\$)	Qty	Tax %	Total
305189	G30 Cocktail Table, Powered White Top, 72"L 26"D 18"H	1,210.00	1,820.00		9.6	\$
305188	Sydney Powered Cocktail Table, Black, 48"L 26"D 18"H	693.00	1,040.00		9.6	\$
305187	Sydney Powered Cocktail Table, White, 48"L 26"D 18"H	693.00	1,040.00		9.6	\$
305017	Table, Cocktail, Geo, Black, 50"L 22"D 16"H	204.25	306.50		9.6	\$
305014	Table, Cocktail, Geo, Chrome, 50"L 22"D 16"H	209.75	315.25		9.6	\$
305020	Table, Cocktail, Inspiration, 42"L 28"D 18"H	274.50	412.00		9.6	\$
305210	Table, Cocktail, Oliver, 47"L 27"D 19"H	247.25	370.75		9.6	\$
305016	Table, Cocktail, Silverado, 36" Round 17"H	241.50	362.50		9.6	\$
305025	Table, Cocktail, Sydney Black, 48"L 26"D 18"H	302.00	453.50		9.6	\$
305024	Table, Cocktail, Sydney White, 48"L 26"D 18"H	302.00	453.50		9.6	\$

B-1 051016 101116 061600445



Specialty Furniture Order Form

All orders are governed by the GES Payment Policy and GES Terms & Conditions of Contract as specified in this Exhibitor Services Manual.

Discount Deadline Date:
October 21, 2016

Company Name _____ Email _____ Phone Number _____

Tables - End Tables

Item Code	Description	Discount (\$)	Regular (\$)	Qty	Tax %	Total
305112	Regis End Table, 16"L 15.5"D 16.5"H	458.00	687.00		9.6	\$
305273	Table, Aura, White Metal, 15" Round 22"H	120.00	180.00		9.6	\$
305274	Table, E, Wood, 21"L 15.5"D 27.5"H	115.00	173.00		9.6	\$
305047	Table, End, Geo, Black, 26"L 26"D 20"H	182.50	274.00		9.6	\$
305044	Table, End, Geo, Chrome, 26"L 26"D 20"H	189.50	284.25		9.6	\$
305049	Table, End, Inspiration, 24"L 28"D 22"H	260.00	390.00		9.6	\$
305211	Table, End, Oliver, 22" Round 22"H	217.25	326.50		9.6	\$
305046	Table, End, Silverado, 24" Round 22"H	226.75	339.75		9.6	\$
305050	Table, End, Sydney, Black, 27"L 23"D 22"H	222.50	334.25		9.6	\$
305048	Table, End, Sydney, White, 27"L 23"D 22"H	222.50	334.25		9.6	\$
305276	Table, Mosaic, Set of 3	224.00	336.00		9.6	\$
305275	Table, Timber, Wood, 16" Round 17"H	141.00	212.00		9.6	\$

Tables - Conference

Item Code	Description	Discount (\$)	Regular (\$)	Qty	Tax %	Total
305190	Powered Conference Table Module, Black, 5"L 2.25"D 2"H	145.00	218.00		9.6	\$
305175	Table, Conf., Geo, Black, 42"L 42"D 29"H	231.00	346.75		9.6	\$
305176	Table, Conf., Geo, Black, 60"L 36"D 29"H	372.75	559.25		9.6	\$
305173	Table, Conf., Geo, Chrome, 42"L 42"D 29"H	245.00	367.25		9.6	\$
305174	Table, Conf., Geo, Chrome, 60"L 36"D 29"H	372.75	559.25		9.6	\$
305027	Table, Conf., Graphite, 42" Round 29"H	307.50	460.75		9.6	\$
305028	Table, Conf., Graphite, 72"L 42"D 29"H	414.50	621.25		9.6	\$
305029	Table, Conf., Graphite, 96"L 48"D 29"H	510.00	765.50		9.6	\$
305033	Table, Conf., Mahogany, 120"L 42"W 29"H	528.00	791.75		9.6	\$
305030	Table, Conf., Mahogany, 42" Round, 42"L 42"W 29"H	304.25	457.00		9.6	\$
305031	Table, Conf., Mahogany, 72"L 42"W 29"H	347.75	521.50		9.6	\$
305032	Table, Conf., Mahogany, 96"L 42"W 29"H	431.00	646.75		9.6	\$
305177	Table, Conf., Manhattan, 42" Round 29"H	280.00	419.25		9.6	\$
305293	Table, Conf., Merlin, Gray Laminate/Black, 46"L 29"D 30"H	305.00	458.00		9.6	\$
305281	Table, Conf., White Laminate, 42" Round 29"H	246.00	369.00		9.6	\$
305208	Table, Nova, Oval, White/Silver Legs, 71"L 35.5"D 29"H	590.25	885.75		9.6	\$

Tables - Martini Bar

Item Code	Description	Discount (\$)	Regular (\$)	Qty	Tax %	Total
305004	Table, Bar, Martini 3 pc., 100"L 100"D 47"H	2,680.00	4,020.75		9.6	\$
305003	Table, Bar, Martini, 50"L 50"D 47"H	1,007.25	1,511.25		9.6	\$

Product Display

Item Code	Description	Discount (\$)	Regular (\$)	Qty	Tax %	Total
305001	Bookcase, Mahogany, 36"L 13"D 71"H	285.25	428.00		9.6	\$
305053	Etagere, Black, 30"L 16"D 70"H	269.75	404.50		9.6	\$
305052	Etagere, Pewter, 30"L 16"D 70"H	269.75	404.50		9.6	\$
305103	Pedestal, Locking Door, Black, 24"L 24"D 42"H	398.25	598.00		9.6	\$

101116 061600445

B-1 051016



Specialty Furniture Order Form

All orders are governed by the GES Payment Policy and GES Terms & Conditions of Contract as specified in this Exhibitor Services Manual.

Discount Deadline Date:
October 21, 2016

Company Name _____ Email _____ Phone Number _____

Product Display						
305297	Pedestal, Powered Locking, Black, 24"L 24"D 30"H	397.00	596.00		9.6	\$
305295	Pedestal, Powered Locking, Black, 24"L 24"D 42"H	474.00	711.00		9.6	\$
305298	Pedestal, Powered Locking, White, 24"L 24"D 30"H	397.00	596.00		9.6	\$
305296	Pedestal, Powered Locking, White, 24"L 24"D 42"H	474.00	711.00		9.6	\$

Office and Utility Furniture

Item Code	Description	Discount (\$)	Regular (\$)	Qty	Tax %	Total
305039	Credenza, Mahogany, 72"L 24"D 29"H	453.25	679.75		9.6	\$
305056	Desk, Executive, Mahogany, 60"L 30"D 29"H	433.00	648.75		9.6	\$
305294	Desk, Writing/Work Table, White Laminate/White, 48"L 24"D 30"H	287.00	431.00		9.6	\$
305058	File, Lateral, Mahogany, 36"L 20"D 29"H	361.75	543.00		9.6	\$

Lamps

Item Code	Description	Discount (\$)	Regular (\$)	Qty	Tax %	Total
305204	Lamp, Floor, Mason, Silver, 18" Round 55"H	295.50	444.00		9.6	\$
305205	Lamp, Table, Mason, Silver, 16" Round 26"H	218.25	327.50		9.6	\$

Accessories

Item Code	Description	Discount (\$)	Regular (\$)	Qty	Tax %	Total
305380	Charging Adapter, Black, 33"L	27.00	40.50		9.6	\$
305381	Charging Adapter, White, 33"L	27.00	40.50		9.6	\$

Electrical Outlets Not Included



Need power for that lamp or powered pedestal in your booth? Order electrical outlets separately for your booth space through the electrical service provider.

Reminder

Total and Sign: Return to Fax: 866.329.1437 • International Fax: 702.263.1520

Please Sign

X

Authorized Signature

Authorized Name - Please Print

Date

I agree in placing this order that I have accepted GES Payment Policy and GES Terms & Conditions of Contract, including authorization for GES to retain personal information to better serve my need for GES services at future events.

Total Payment Enclosed

\$

Cancellation Policy: Items cancelled will be charged **100%** of original price after move-in begins.

101116 061600445

B-1 051016



Convenience Package Order Form

All orders are governed by the GES Payment Policy and GES Terms & Conditions of Contract as specified in this Exhibitor Services Manual.

Seattle International Auto Show
 CenturyLink Field Event Center
 November 10 - 13, 2016

Discount Deadline Date:
 October 21, 2016

Company Name _____ Email _____ Phone Number _____ Booth Number _____



Easy Ordering Tips:

- All prices include delivery, rental, and removal.
- Return your orders three (3) weeks before show move-in to ensure availability. At show site some items may not be available and substitutions might be necessary.
- Enjoy a fast and easy ordering experience online with Expresso:
<http://e.ges.com/061600445/packages/esm>



Barcelona Club Package



Deluxe Chair Package



Stool Package A



Chair Package A

Standard Furniture Package

Item Code	Description	Discount (\$)	Regular (\$)	Qty	Tax %	Total
404301	Chair Package A	356.45	535.50		9.6	\$
	↳ Includes: (2) Contemporary Arm Chairs, (1) Starbase Table 40"X30", (1) Wastebasket.					
404311	Stool Package A	370.45	556.00		9.6	\$
	↳ Includes: (2) Contemporary Stools, (1) Starbase Table 30"X40", (1) Wastebasket.					

Standard Skirted Furniture Package

Item Code	Description	Color Code	Discount (\$)	Regular (\$)	Qty	Tax %	Total
4046	Chair Package B		308.20	463.00		9.6	\$
	↳ Includes: (2) Contemporary Arm Chairs, (1) 6' Skirted Table 24"X30", (1) Wastebasket.						
4146	Stool Package B		336.20	504.75		9.6	\$
	↳ Includes: (2) Contemporary Stools, (1) 6' Skirted Counter 24"X42", (1) Wastebasket.						

Skirt Color Options

(Gray will be provided if no color is indicated.)



Specialty Furniture Package

Item Code	Description	Discount (\$)	Regular (\$)	Qty	Tax %	Total
404504	Bar Package	1,506.75	2,260.75		9.6	\$
	↳ Includes: (2) White Oslo Barstools, (1) Martini Bar.					
404501	Barcelona Club Package	1,604.50	2,405.50		9.6	\$
	↳ Includes: (2) Black Barcelona Chairs, (1) Inspiration End Table.					
404503	Deluxe Chair Package	651.00	978.25		9.6	\$
	↳ Includes: (2) New York Chairs, (1) Cafe Table 36"X29".					

P-1 031416 101116 061600445

Form Continues on Next Page



Convenience Package Order Form

All orders are governed by the GES Payment Policy and GES Terms & Conditions of Contract as specified in this Exhibitor Services Manual.

Company Name _____ Email _____ Phone Number _____

Specialty Furniture Package

404505	Premium Pedestal Package	671.75	1,008.50		9.6	\$
↳ Includes: (2) Black Banana Barstools, (1) Locking Pedestal.						

Total and Sign: Return to Fax: 866.329.1437 • International Fax: 702.263.1520

Please Sign

X

Authorized Signature

Authorized Name - Please Print

Date

I agree in placing this order that I have accepted GES Payment Policy and GES Terms & Conditions of Contract, including authorization for GES to retain personal information to better serve my need for GES services at future events.

Total Payment Enclosed

\$

Cancellation Policy: Package items cancelled will be charged **50%** of original price after move-in begins and **100%** of original price after installation.

101116 061600445

P-1 031416



Standard Exhibit Systems

With 5 GES® standard exhibits to choose from, selecting the size and configuration that meets your tradeshow needs is easy. Our modular exhibits are hassle-free because you pay no design fees, no shipping fees, and no repair or refurbishing fees. Plus, you may customize the trim and panels, and choose from a wide variety of accessories to create a unique exhibit that reinforces your brand and marketing efforts.

All packages include rental, delivery, installation, and dismantling. For other custom furnishings, hanging signs, or graphics, chat with your GES National Servicenter® representative at www.ges.com/chat.

20x20 Exhibits

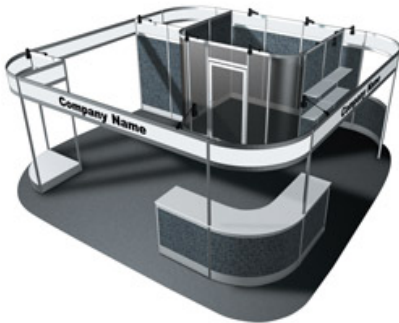

600005 - Exhibit System GEM #5, 20'x20' Island Includes:

- three digitally printed signs
- one locking office
- four shelves
- one curved counter
- two 1m counters
- ten arm lights
- one standard 20' x 20' carpet
- no padding

10x20 Exhibits



600004 - Exhibit System GEM #4, 10'x20' Inline Includes:

- one 117" x 12" digitally printed sign
- one 57-7/8" x 12" digitally printed sign
- one 2m counter
- six arm lights
- five shelves
- one standard 10' x 20' carpet
- no padding

10x10 Exhibits



600002 - Exhibit System GEM #2, 10'x10' Inline Includes:

- one custom ID sign
- two arm lights
- one standard 10' x 10' carpet
- no padding



600003 - Exhibit System GEM #3, 10'x10' Inline Includes:

- one custom ID sign
- three arm lights
- five shelves
- one 1m counter
- one standard 10' x 10' carpet
- no padding

6ft Table Display



600001 - Exhibit System GEM #1, 6' Tabletop Display Includes:

- one custom ID sign
- three arm lights
- two shelves
- one 6' skirted table
- no carpet and padding

Please note that although arm lights may be included in your package, electrical power must be ordered separately through the electrical services provider in your exhibitor service manual. Colors may vary due to facility lighting, printing limitations and dye lot differences.

Standard Exhibit Systems

Accessories



600410 - Exhibit, Ad Board, 1M x 8'



600110 - Exhibit, Armlight Black



600103 - Exhibit, Counter, 1M Curved



600101 - Exhibit, Counter, 1M x 1/2M x 40"H



600102 - Exhibit, Counter, 2M x 1/2M x 40"H



600221 - Exhibit, Light Box, Large 37"x85"



600222 - Exhibit, Light Box, Medium 37"x56"



600223 - Exhibit, Light Box, Small 37"x28"



661931 - Exhibit, Panel, Slatwall, 1M x 8'

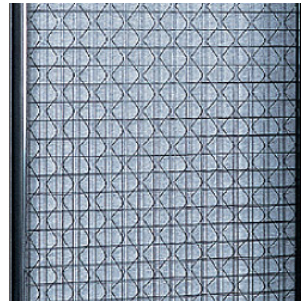

600291 - Exhibit, Panel, Wirewall, 1M



600243 - Exhibit, Shelf, 1M x 10" Deep

Trim and Panel Choices

Panel Type & Color

● Coated: Black (C41)

○ Coated: Oxford White (C50)

● Coated: Prism Blue (C42)

● Coated: Silver Gray (C79)

● Fabric: Black (F41)

● Fabric: Blue (F42)

● Fabric: Gray (F40)

Trim Color

● Black (41)

● Silver (79)

Please note that although arm lights may be included in your package, electrical power must be ordered separately through the electrical services provider in your exhibitor service manual. Colors may vary due to facility lighting, printing limitations and dye lot differences.

Standard Exhibits Graphics

Exhibit #1, 6' Tabletop (600001)

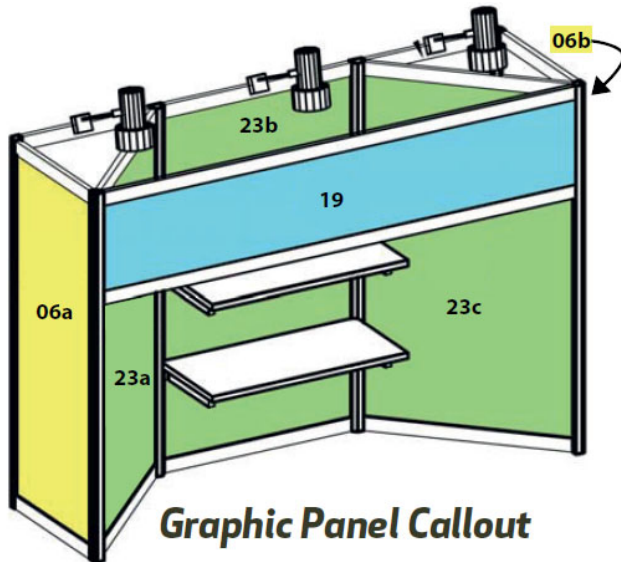

Graphic Panel Callout

- 23** 608323 26 9/16" wide x 45" tall
Discount Price - \$137.00 /Regular Price - \$205.00
Produced on 3/16" Thick White Foamcore
- 06** 608306 18 7/16" wide x 45" tall
Discount Price - \$56.75 /Regular Price - \$144.25
Produced on 3/16" Thick White Foamcore
- 19** 608319 65 15/16" wide x 12" tall
Discount Price - \$90.75 /Regular Price - \$136.00
Produced on 3/16" Thick White Foamcore

All Prices listed above are Per Panel.

Please note that pricing listed is for Graphic Panels only. GEM units are rented separately.

GES requires a form of payment for booth graphics in order to produce signage. Please see Payment and Credit Card Authorization (G-2) for required information.

Please contact GES National Service Center at 800-475-2098 or 702-515-5970 with any questions or concerns.

Link: <https://e.ges.com/061600445/exhibit1/esm>



Booth Rendering

Please note that although arm lights may be included in your package, electrical power must be ordered separately through the electrical services provider in your exhibitor service manual. Colors may vary due to facility lighting, printing limitations and dye lot differences.

Standard Exhibits Graphics

Exhibit #2, 10 x 10 (600002)

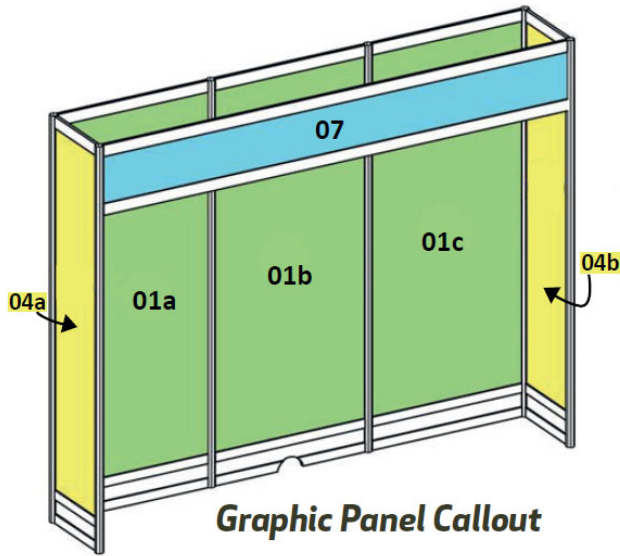

- 01** 608301 38 1/8" wide x 86 1/4" tall
 Discount Price - \$376.00 /Regular Price - \$564.50
 Produced on 3/16" Thick White Foamcore
- 04** 608304 18 7/16" wide x 86 1/4" tall
 Discount Price - \$188.50 /Regular Price - \$283.25
 Produced on 3/16" Thick White Foamcore
- 07** 608307 117" wide x 12" tall
 Discount Price - \$160.75 /Regular Price - \$241.00
 Produced on 3/16" Thick White Foamcore

All Prices listed above are Per Panel.

Please note that pricing listed is for Graphic Panels only. GEM units are rented separately.

GES requires a form of payment for booth graphics in order to produce signage. Please see Payment and Credit Card Authorization (G-2) for required information.

Please contact GES National Service Center at 800-475-2098 or 702-515-5970 with any questions or concerns.

Link: <https://e.ges.com/061600445/exhibit2/esm>



Booth Rendering

Please note that although arm lights may be included in your package, electrical power must be ordered separately through the electrical services provider in your exhibitor service manual. Colors may vary due to facility lighting, printing limitations and dye lot differences.

Standard Exhibits Graphics

Exhibit #3, 10 x 10 (600003)

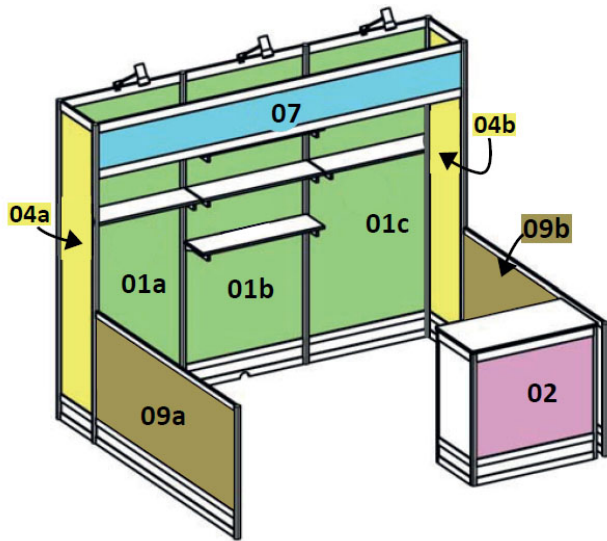

Graphic Panel Callout

- 01** 608301 38 1/8" wide x 86 1/4" tall
 Discount Price - \$376.00 /Regular Price - \$564.50
 Produced on 3/16" Thick White Foamcore
- 04** 608304 18 7/16" wide x 86 1/4" tall
 Discount Price - \$188.50 /Regular Price - \$283.25
 Produced on 3/16" Thick White Foamcore
- 07** 608307 117" wide x 12" tall
 Discount Price - \$160.75 /Regular Price - \$241.00
 Produced on 3/16" Thick White Foamcore
- 02** 608302 38 1/8" wide x 30 1/4" tall
 Discount Price - \$131.75 /Regular Price - \$197.75
 Produced on 3/16" Thick White Foamcore
- 09** 608309 77 1/2" wide x 30 1/4" tall
 Discount Price - \$267.75 /Regular Price - \$401.75
 Produced on 3/16" Thick White Foamcore

All Prices listed above are Per Panel.

Please note that pricing listed is for Graphic Panels only. GEM units are rented separately.

GES requires a form of payment for booth graphics in order to produce signage. Please see Payment and Credit Card Authorization (G-2) for required information.

Please contact GES National Service Center at 800-475-2098 or 702-515-5970 with any questions or concerns.

Link: <https://e.ges.com/061600445/exhibit3/esm>



Booth Rendering

Please note that although arm lights may be included in your package, electrical power must be ordered separately through the electrical services provider in your exhibitor service manual. Colors may vary due to facility lighting, printing limitations and dye lot differences.

Standard Exhibits Graphics

Exhibit #4, 10 x 20 (600004)

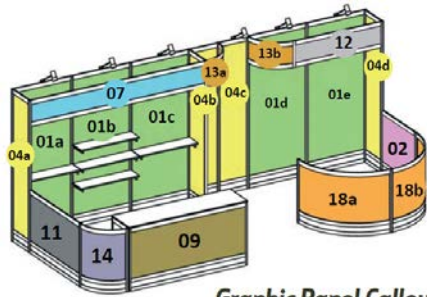

Graphic Panel Callout

- 12** 608312 57 7/8" wide x 12" tall
Discount Price - \$82.50 /Regular Price - \$123.50
Produced on 3/16" Thick White Foamcore
- 13** 608313 29 3/4" wide x 12" tall
Discount Price - \$41.25 /Regular Price - \$61.75
Produced on 1/8" Thick White Foamacell
- 18** 608318 60 3/4" wide x 30 1/4" tall
Discount Price - \$210.00 /Regular Price - \$315.25
Produced on 1/8" Thick White Foamacell
- 09** 608309 77 1/2" wide x 30 1/4" tall
Discount Price - \$267.75 /Regular Price - \$401.75
Produced on 3/16" Thick White Foamcore
- 14** 608314 29 3/4" wide x 30 1/4" tall
Discount Price - \$103.00 /Regular Price - \$154.50
Produced on 1/8" Thick White Foamacell

- 01** 608301 38 1/8" wide x 86 1/4" tall
Discount Price - \$376.00 /Regular Price - \$564.50
Produced on 3/16" Thick White Foamcore
- 04** 608304 18 7/16" wide x 86 1/4" tall
Discount Price - \$188.50 /Regular Price - \$283.25
Produced on 3/16" Thick White Foamcore
- 11** 608311 57 7/8" wide x 30 1/4" tall
Discount Price - \$79.25 /Regular Price - \$119.50
Produced on 3/16" Thick White Foamcore
- 02** 608302 38 1/8" wide x 30 1/4" tall
Discount Price - \$131.75 /Regular Price - \$197.75
Produced on 3/16" Thick White Foamcore
- 07** 608307 117" wide x 12" tall
Discount Price - \$160.75 /Regular Price - \$241.00
Produced on 3/16" Thick White Foamcore



Booth Rendering

All Prices listed above are Per Panel.

Please note that pricing listed is for Graphic Panels only. GEM units are rented separately.

GES requires a form of payment for booth graphics in order to produce signage. Please see Payment and Credit Card Authorization (G-2) for required information.

Please contact GES National Service Center at 800-475-2098 or 702-515-5970 with any questions or concerns.

Link: <https://e.ges.com/061600445/exhibit4/esm>

Please note that although arm lights may be included in your package, electrical power must be ordered separately through the electrical services provider in your exhibitor service manual. Colors may vary due to facility lighting, printing limitations and dye lot differences.

Standard Exhibits Graphics

Exhibit #5, 20 x 20 (600005)

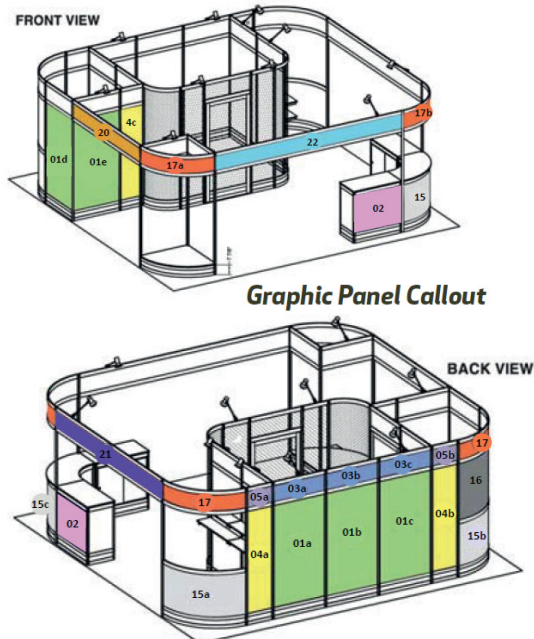

- 21** 608321 136 9/16" wide x 12" tall
Discount Price - \$123.50 /Regular Price - \$188.50
Produced on 3/16" Thick White Foamcore
- 20** 608320 97 3/16" wide x 12" tall
Discount Price - \$132.75 /Regular Price - \$199.75
Produced on 1/8" Thick White Foamcore
- 17** 608317 60 11/16" wide x 12" tall
Discount Price - \$153.50 /Regular Price - \$220.50
Produced on 1/8" Thick White Foamacell
- 02** 608302 38 1/8" wide x 30 1/4" tall
Discount Price - \$131.75 /Regular Price - \$197.75
Produced on 3/16" Thick White Foamcore
- 03** 608303 38 1/8" wide x 12" tall
Discount Price - \$52.50 /Regular Price - \$78.25
Produced on 3/16" Thick White Foamcore
- 05** 608305 18 7/16" wide x 12" tall
Discount Price - \$41.25 /Regular Price - \$61.75
Produced on 3/16" Thick White Foamcore

- 01** 608301 18 7/16" wide x 86 1/4" tall
Discount Price - \$376.00 /Regular Price - \$564.50
Produced on 3/16" Thick White Foamcore
- 04** 608304 18 7/16" wide x 86 1/4" tall
Discount Price - \$188.50 /Regular Price - \$283.25
Produced on 3/16" Thick White Foamcore
- 16** 608316 60 11/16" wide x 40 1/4" tall
Discount Price - \$251.25 /Regular Price - \$356.50
Produced on 1/8" Thick White Foamacell
- 15** 608315 60 11/16" wide x 30 1/4" tall
Discount Price - \$210.00 /Regular Price - \$315.25
Produced on 1/8" Thick White Foamacell
- 22** 608322 156 1/4" wide x 12" tall
Discount Price - \$213.25 /Regular Price - \$321.25
Produced on 3/16" Thick White Foamcore

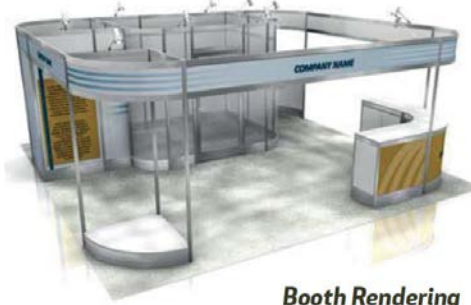

Booth Rendering

All Prices listed above are Per Panel.

Please note that pricing listed is for Graphic Panels only. GEM units are rented separately.

GES requires a form of payment for booth graphics in order to produce signage. Please see Payment and Credit Card Authorization (G-2) for required information.

Please contact GES National Service Center at 800-475-2098 or 702-515-5970 with any questions or concerns.

Link: <https://e.ges.com/061600445/exhibit5/esm>

Please note that although arm lights may be included in your package, electrical power must be ordered separately through the electrical services provider in your exhibitor service manual. Colors may vary due to facility lighting, printing limitations and dye lot differences.

Exhibit Systems Order Form

All orders are governed by the GES Payment Policy and GES Terms & Conditions of Contract as specified in this Exhibitor Services Manual.

Seattle International Auto Show
 CenturyLink Field Event Center
 November 10 - 13, 2016

Discount Deadline Date:
 October 21, 2016

Company Name _____ Email _____ Phone Number _____ Booth Number _____



Easy Ordering Tips:

- All prices include delivery, rental, and removal.
- Return your orders three (3) weeks before show move-in to ensure availability. At show site some items may not be available and substitutions might be necessary.
- Arm lights and shelves cannot be placed on pipe and drape.

13 oz. Carpet Color Options

(Gray will be provided if no color is indicated below)



Exhibit Panel Color Options

(Gray Fabric Panel will be provided if no color is indicated below)



C Color Codes are Coated Panels
 F Color Codes are Fabric

Trim Color Options

(Silver will be provided if no color is indicated below)

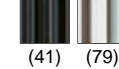

Standard Exhibits

10x10 Exhibits

Item Code	Description	Discount (\$)	Regular (\$)	Qty	Tax %	Total
600002	Exhibit System GEM #2, 10'x10' Inline	1,730.00	2,600.00		9.6	\$
	↳ Carpet Color Code: _____ Trim Color: _____ Panel Color: _____					
600003	Exhibit System GEM #3, 10'x10' Inline	3,270.00	4,910.00		9.6	\$
	↳ Carpet Color Code: _____ Trim Color: _____ Panel Color: _____					

10x20 Exhibits

Item Code	Description	Discount (\$)	Regular (\$)	Qty	Tax %	Total
600004	Exhibit System GEM #4, 10'x20' Inline	7,180.00	10,770.00		9.6	\$
	↳ Carpet Color Code: _____ Trim Color: _____ Panel Color: _____					

20x20 Exhibits

Item Code	Description	Discount (\$)	Regular (\$)	Qty	Tax %	Total
600005	Exhibit System GEM #5, 20'x20' Island	10,670.00	16,010.00		9.6	\$
	↳ Carpet Color Code: _____ Trim Color: _____ Panel Color: _____					

Accessories

Item Code	Description	Discount (\$)	Regular (\$)	Qty	Tax %	Total
600410	Exhibit, Ad Board, 1M x 8'	459.75	689.50		9.6	\$
600110	Exhibit, Armlight Black	68.00	102.50		9.6	\$
600103	Exhibit, Counter, 1M Curved	634.75	952.00		9.6	\$
	↳ Trim Color: _____ Panel Color: _____					
600101	Exhibit, Counter, 1M x 1/2M x 40"H	320.25	480.50		9.6	\$
	↳ Trim Color: _____ Panel Color: _____					
600102	Exhibit, Counter, 2M x 1/2M x 40"H	439.25	659.25		9.6	\$
	↳ Trim Color: _____ Panel Color: _____					
600221	Exhibit, Light Box, Large 37"x85"	583.50	875.75		9.6	\$
600222	Exhibit, Light Box, Medium 37"x56"	461.00	691.50		9.6	\$
600223	Exhibit, Light Box, Small 37"x28"	284.00	426.50		9.6	\$
661931	Exhibit, Panel, Slatwall, 1M x 8'	402.00	603.00		9.6	\$
600291	Exhibit, Panel, Wirewall, 1M	392.75	589.25		9.6	\$
600243	Exhibit, Shelf, 1M x 10" Deep	53.75	80.25		9.6	\$

D-1 092716 101116 061600445



Exhibit Systems Order Form

All orders are governed by the GES Payment Policy and GES Terms & Conditions of Contract as specified in this Exhibitor Services Manual.

Discount Deadline Date:
October 21, 2016

Company Name _____ Email _____ Phone Number _____

Electrical or Utilities Under Carpet?

Yes No

Total and Sign: Return to Fax: 866.329.1437 • International Fax: 702.263.1520

Please
Sign

X

Authorized Signature

Authorized Name - Please Print

Date

I agree in placing this order that I have accepted GES Payment Policy and GES Terms & Conditions of Contract, including authorization for GES to retain personal information to better serve my need for GES services at future events.

Total Payment
Enclosed

\$

Cancellation Policy: Items cancelled will be charged **50%** of original price after move-in begins and **100%** of original price after installation.

101116 061600445

D-1 092716



Digital File Preparation

All orders are governed by the GES Payment Policy and GES Terms & Conditions of Contract as specified in this Exhibitor Services Manual.

Seattle International Auto Show
CenturyLink Field Event Center
November 10 - 13, 2016

Graphic File Solutions

We are committed to partnering with you to provide comprehensive and effective graphic solutions for your event. The graphics print and production industry continuously evolves, and we want your graphics and images to look their absolute best.

To ensure the highest quality output from your digital files, and to make file transfers as seamless as possible, please review and follow these guidelines when submitting artwork to GES. We also offer layout and design services for a fee. Please contact GES for details.

Suitable Programs for images or logos	
Program	Preferred Format
Adobe Illustrator CS6, CC 2014	.ai, .eps
Adobe Photoshop CS6, CC 2014	.tif (LZW), .jpg (High Quality), .psd
Adobe InDesign CS6, CC 2014	.indd (include all links)
Adobe Acrobat	.pdf (Press Quality Setting)

Suitable Media for images or logos	
Media	Preferred Format
CD-ROM	Hard copy color proofs
DVD-ROM	Hard copy color proofs
Email Attachments	Limited to maximum size of 5MB
FTP	Mandatory ZIP or SIT compression



- Save money by providing your artwork/graphic files in the recommended formats.
- Send your graphics early with client name, show name, and booth number to avoid costly delays.
- Do not copy graphics from web pages as they will be low resolution and not suitable for your exhibit/sign.

Avoiding Additional Costs

Files obtained from the internet (.jpg or .gif) or artwork created in MS Office applications (Word, Excel, PowerPoint) are often not suitable for high quality output, and often require additional hourly charges. Artwork should be created at actual size, however, for larger files i.e., banner artwork, 10% or 25% of actual size is acceptable. Scans should be no smaller than 300dpi at quarter size. To avoid additional costs associated with these file types, please supply files in accordance as defined herein.

Vector Artwork

For the best quality, create in vector format (ai or vector eps).

Logos taken from websites are generally GIF files. GIF files are not acceptable as they will not print clearly. See Visual.

Artwork produced in vinyl, for example, solid company logos or text must be supplied in a vector format (ai or vector eps). Artwork created in a pixel format i.e., TIFF and JPEG is not suitable. See Visual.

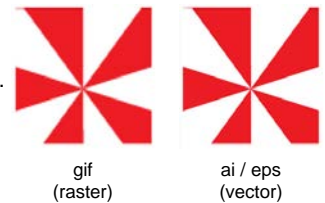

Bitmap/Raster Artwork

TIFF and PSD - These are the preferred file formats for raster images. Files should be supplied at 100dpi at full size, or they should re-scale to those dimensions. If the resolution is lower than 100dpi, images can look blurry or pixelated when printed. If there is a lot of small text in the raster image, the file can be provided at higher resolutions to ensure print quality. See Visual.

JPEG - We can use JPEG files, but because JPEGs use file compression this can sometimes affect image quality. Therefore, this file type should only be used if the files are being emailed.

PDF - These are print files only and cannot be altered to fit different sizes, artwork must be set up at the correct proportion and at print-ready quality. Ensure images are saved at high resolution (100dpi at final size).

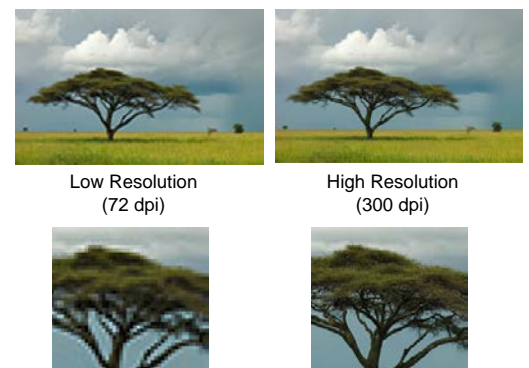

Order graphics and **upload artwork files** directly online, click here: <https://e.ges.com/061600445/signs>

061600445

101116 1518

I-2 071415

Digital File Preparation

All orders are governed by the GES Payment Policy and GES Terms & Conditions of Contract as specified in this Exhibitor Services Manual.

Seattle International Auto Show
CenturyLink Field Event Center
November 10 - 13, 2016

Front and Backlit Graphics

When producing artwork for front lit graphics or transparencies keep these points in mind:

- Avoid setting type in Photoshop — instead use a vector-based program (such as Adobe Illustrator) for your type. If you do use vector smart objects, save the file as an .eps or .psd to retain vector properties.
- If you plan to add effects to your type (such as drop shadows or glows), follow these steps:
 - a. Import the Illustrator type into Photoshop
 - b. Add effects to the type
 - c. Separate the effects onto a layer
 - d. Delete the type layer
 - e. Assemble the type and photo in a vector program.
- Always provide logos in a vector format.
- If you have critical PMS colors to match, provide us with a layered Photoshop file to allow for color editing.
- Always add at least 1" of bleed to your images.
- Use gradients carefully and sparingly. Gradients often "band," and little can be done to correct the problem. Look at your high res file at 100% — if you can see the banding, it WILL appear in the print. Adding 1 pt. of noise to the file may resolve the problem.

File Sizes

Please build Photoshop (raster) graphics to at least 100dpi at final size. Any combination of size/resolution that produces this result is acceptable.

(e.g. 1/4 size file @400dpi)

Here is an easy way to determine how much digital information is needed for your graphic:

- Open a new document in Photoshop
- Enter the final width and height of your graphic.
- Enter a resolution of 100 dpi

The resulting megabyte size is the approximate amount of digital information we need for best quality output.

Adobe Illustrator, InDesign, Photoshop

- Work with .eps files as much as possible. .eps files are a better quality file format than .tif files and are accepted more easily by Adobe Illustrator.
- Save a Low Res version of your files for proofing and a Hi Res file for production. Illustrator allows for seamless swapping of LR and HR files provided the images are the same dimensions.
- When saving your HR file, use the settings shown in *figure a*. This will compress the information in the file without degrading the quality. High resolution files saved with this setting present no issues for our output devices.
- If you must work with a .tif file because you are colorizing it in illustrator, save the HR file with the LZW compression option.
- Keep all color-critical elements of your design vector whenever possible. Don't send the layered Photoshop unless you need critical color corrections. If you want to add a Photoshop effect to a logo or color critical text: set the text in illustrator or keep the logo vector, create the desired effect in Photoshop, then link the Photoshop file into Illustrator under the color critical vector art or text.
- Photoshop files with text or vector smart objects need to be saved out as .eps or .psd to retain vector properties.

Placed Images

Provide placed images at 100dpi at 100% of final size as a .tif (LZW compression) or .psd. Embedding images in Illustrator is preferred and need to be 100dpi at final size.

Fonts

Turn all fonts to outlines or convert to paths before sending the files. If you are using a program where this is not an option, YOU MUST INCLUDE ALL FONTS with your files. OTF (open type fonts). are preferred.

Vinyl

We can only produce vinyl for type or logos from VECTOR based artwork. DO NOT send PowerPoint files, .gifs, .jpgs, .pdfs or raster-based images output to vinyl.

Remember

- You MUST add bleed to your photographic images.
- Backlit graphics are held in place with velcro or with a frame—place type and critical images at least 1" from all edges to avoid this dead space (see diagram below).
- You MUST provide PMS colors. We are not responsible for accurate reproduction of your logo or corporate colors if PMS matches are not provided.
- Please make certain that your scans are clean (free of dust, dirt, and scratches) BEFORE you send them for production. Deadlines and time constraints do not allow us to check all your images for quality. We must assume the images you provide are the highest quality available to you. To check for quality, look at your Photoshop files at 100% enlargement. If you can see dirt and scratches, they will appear on your final output. Use the rubber stamp tool (clone stamp tool) to eliminate these imperfections.

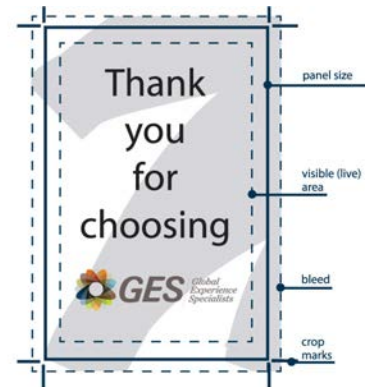

figure a.

Graphics and Signage Order Form

All orders are governed by the GES Payment Policy and GES Terms & Conditions of Contract as specified in this Exhibitor Services Manual.

Seattle International Auto Show
 CenturyLink Field Event Center
 November 10 - 13, 2016

Discount Deadline Date:
 October 21, 2016

Company Name _____ Email _____ Phone Number _____ Booth Number _____

Order graphics and **upload artwork files** directly online, click here: <https://e.ges.com/061600445/signs/esm>

Graphics and Signage

Item Code	Description	Discount (\$)	Regular (\$)	Qty	Tax %	Total
600534	22"W x 28"H Vertical Sign w/ Sign Holder, Double Sided	233.25	312.75		9.6	\$
600533	22"W x 28"H Vertical Sign w/ Sign Holder, Single Sided	180.25	259.75		9.6	\$
600535	72"W x 36"H Vinyl Banner (horizontal or vertical) w/ Silver Grommets, Single Sided	191.00	297.25		9.6	\$
600852	Freestanding 24"W x 84"H Vertical Ad Board w/ Cardboard Base, Double Sided	344.75	397.75		9.6	\$
600850	Freestanding 24"W x 84"H Vertical Ad Board w/ White Cardboard Base, Single Sided	212.25	265.25		9.6	\$
600853	Freestanding 38"W x 84"H Vertical Ad Board w/ White Cardboard Base, Double Sided	451.00	504.00		9.6	\$
600851	Freestanding 38"W x 84"H Vertical Ad Board w/ White Cardboard Base, Single Sided	318.25	371.25		9.6	\$
601099	Printed Cardboard Base for Freestanding Boards	20.75	20.75		9.6	\$

Total and Sign: Return to Fax: 866.329.1437 • International Fax: 702.263.1520

Please Sign

X

Authorized Signature

Authorized Name - Please Print

Date

I agree in placing this order that I have accepted GES Payment Policy and GES Terms & Conditions of Contract, including authorization for GES to retain personal information to better serve my need for GES services at future events.

Total Payment Enclosed

\$

101116 061600445

I-1 051016



Standard Graphics

38" Ad Board

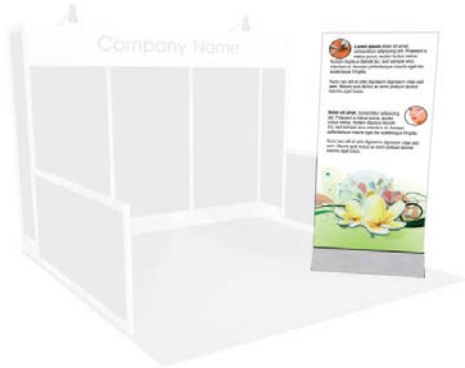

600851 Freestanding 38"W x 84"H Vertical Ad Board w/ White Cardboard Base, Single Sided (includes cardboard base, graphic & delivery)

600853 Freestanding 38"W x 84"H Vertical Ad Board w/ White Cardboard Base, Double Sided

*Includes cardboard base, graphic and delivery.
Printed base available at additional cost.*

24" Ad Board



600850 Freestanding 24"W x 84"H Vertical Ad Board w/ White Cardboard Base, Single Sided (includes cardboard base, graphic & delivery)

600852 Freestanding 24"W x 84"H Vertical Ad Board w/ Cardboard Base, Double Sided

*Includes cardboard base, graphic and delivery.
Printed base available at additional cost.*

22" x 28" with Sign Holder



600533 22"W x 28"H Vertical Sign w/ Sign Holder, Single Sided

600534 22"W x 28"H Vertical Sign w/ Sign Holder, Double Sided

Includes sign holder rental, graphic and delivery.

6' x 3' Banner



600535 72"W x 36"H Vinyl Banner (horizontal or vertical) w/ Silver Grommets, Single Sided

*Banner is available horizontal or vertical.
Includes silver grommets.*

Material Handling/Drayage Information

All orders are governed by the GES Payment Policy and GES Terms & Conditions of Contract as specified in this Exhibitor Services Manual.

Seattle International Auto Show
CenturyLink Field Event Center
November 10 - 13, 2016

Benefits of Advance Shipping to the GES Warehouse

- Storage of materials for up to 30 days prior to your show.
- Delivery of Shipments to your booth by your published set-up time.
- Some convention centers and hotels do not have facilities for receiving or storing freight.
- Saves valuable set-up time.

How to Ship in Advance to the GES Warehouse

- Remove all old shipping and empty storage labels.
- Fill out and attach enclosed Advance Shipping labels.
- Complete the enclosed Material Handling/Drayage Order Form.
- Remember to confirm receipt of your shipment prior to leaving for the show.
- All shipments must have a bill of lading or delivery slip showing the number of pieces, weight, and type of merchandise.
- Certified weight tickets must accompany all shipments.
- Take the time to ensure that your display and products are packed neatly and securely.
- Do not ship uncrated materials to warehouse.

How to Ship to Exhibit Site

- Consign all domestic shipments c/o GES.
- Remove all old shipping and empty storage labels.
- Fill out and attach enclosed Direct Shipping labels.
- Complete the enclosed Material Handling Information Sheet.
- All shipments must have a bill of lading or delivery slip showing the number of pieces, weight, and type of merchandise.
- Certified weight tickets must accompany all shipments.
- Take the time to ensure that your display and products are packed neatly and securely.
- If you are shipping your carpet and/or lighting truss, make sure it is loaded last so it can be unloaded first.

Freight Carriers

Select a carrier with experience in handling exhibition materials. Make sure to give your carrier explicit information as to where and when to check in. Delivery and pick up times are often out of the range of normal delivery hours, make sure your carrier is committed to meeting your target dates and times. While making shipping plans to the Show, also plan for the return shipment.

Tracking Shipments

Confirm your delivery date and time with your carrier, and have all pertinent shipping information in the hands of your representative at show site. You may also want to review the return of your Goods at the end of the show. GES Logistics domestic shipments can be tracked online by going to:

www.ges.com/everything/logistics/tracking/.

Get an instant quote today at <http://logisticsquote.ges.com/>

Estimating Material Handling Charges

Handling charges are based on the weight of the freight. Shipments are billed by the hundred weight and rounded up to the nearest hundred. Minimum per Shipment may apply, see enclosed Material Handling/Drayage Order Form for details. Please prepay all shipping charges - GES cannot accept or be responsible for collect shipments. Crated and uncrated shipments must be separated and clearly identified on separate bills of lading with separate weight tickets - otherwise GES will invoice the entire load at the Uncrated rate.

- Crated - Material that is skidded, or is in any type of shipping container that can be unloaded at the dock with no additional handling required.
- Uncrated - Material that is shipped loose or pad-wrapped, and/or unskidded machinery without proper lifting bars or hooks.
- Special Handling - Defined as shipments that are loaded by cubic space and/or packed in such a manner as to require special handling, such as ground loading, side door loading, constricted space loading and designated piece loading or stacked shipments. Also included are mixed shipments and shipments without proper delivery receipts.
- Overtime Surcharges - Shows that move-in or move-out on weekends or after 4:30 PM during the weekday, may be subject to additional overtime surcharges. See enclosed Material Handling/Drayage Order Form for details.

Late Surcharges - May be charged an additional overtime surcharge

- If advance freight is received before or after the published deadline date for shipments to arrive at the warehouse. See enclosed Material Handling/Drayage Order Form for details.
- Freight shipments sent to the show after it has opened.
- Freight shipments that are received at showsite that do not meet their published date and time.
- Shipment Surcharges - A surcharge will be incurred per shipment for those that are received with incomplete information on shipping labels identifying company name and booth number and/or shipments that are left on the show floor at the end of the show with no labels and no bill of lading turned in.

Machinery Labor and Equipment

Labor and equipment for uncrating, unskidding, positioning, leveling, dismantling, recrating, and reskidding machinery and/or equipment must be ordered separately. Place your order for this labor using the Forklift Labor Order Form. If your material requires specialized rigging equipment, please notify us promptly so that we can make arrangements. When possible, supply your own rigging equipment with shipments and pre-rig your material.

Storing Empty Containers

Properly labeled empty shipping cartons will be picked up, stored, and returned after the show. Labels are available at the GES Servicenter® or from your GES Service Executive and are for empty storage only. Depending on the size of the show, it can take from two to twelve hours to return empty crates. Do not store any items in crates marked "empty." GES has no liability for damage to crates or items sent to empty storage in crates.

Outgoing Shipments

An OMHF (Outbound Material Handling Form / Bill of Lading) must accompany all outgoing shipments. Shipping information, outbound forms and labels will be available at the GES Servicenter®. Exhibitors selecting non-official carriers will need to make their own arrangements for pickup. Make sure that someone from your company will be on-site to oversee the outbound shipment of your display and product.

101116 061600445

R-1 090816

Measure of Damage

- Liability - GES is liable for loss or damage to your goods only if the loss or damage is caused by GES negligence.
- Sole Relief - If found liable for any loss, GES' sole and exclusive maximum liability for loss or damage to Customer's goods is limited to \$.50 (USD) per pound with a maximum liability of \$100 (USD) per container, or \$1,500.00 (USD) per shipment, whichever is less.

Insurance

All of your goods should be insured by your own insurance policy. Although we do our best to handle your goods as our own, there are many variables in shipping and handling that can affect your exhibit and products. GES has published GES Terms and Conditions of Contract that are in this exhibitor service manual. Please read them carefully. It is recommended that your goods be insured.

Work Zone





Customer acknowledges that the show site and surrounding areas are active work zones. Customer, its agents, employees and representatives are present at their own risk.



Save 10% on Material Handling with GES Transportation Plus.

GES is your one stop shop for event and trade show transportation. As the Official Services Provider, we can offer you competitive pricing and a seamless shipping experience along with these Transportation Plus benefits:



-  10% off material handling
-  GES on-site support professionals
-  24/7 online shipment tracking: <http://www.ges.com/us/logistics/tools>
-  Consolidated show invoice
-  Fully integrated storage and shipping solutions



Order your round-trip shipping today to qualify for 10% off material handling fees.

Get an instant quote today at: https://e.ges.com/061600445/logistics_quote

Discount does not apply to shipments that are considered small packages, local or shipments over 5,000 lbs.

Material Handling/Drayage Order Form

All orders are governed by the GES Payment Policy and GES Terms & Conditions of Contract as specified in this Exhibitor Services Manual.

Seattle International Auto Show
 CenturyLink Field Event Center
 November 10 - 13, 2016

Discount Deadline Date:
 October 21, 2016

Company Name _____ Email _____ Phone Number _____ Booth Number _____



Easy Ordering Tips:

- Material Handling is the unloading and delivery of exhibit freight to the exhibitor's booth on the show floor. Material handling charges will be invoiced to you at show site for any freight unloaded and delivered. Use this form to plan, estimate costs and pre-order this service.
- Crated Material is skidded, or is in any type of shipping container that can be unloaded at the dock with no additional handling required.
- Special Handling is defined as shipments that are loaded by cubic space and/or packed in such a manner as to require special handling, such as ground loading, side door loading, constricted space loading and designated piece loading or stacked shipments. Also included are mixed shipments and shipments without proper delivery receipts.
- Uncrated Material is shipped loose or pad-wrapped, and/or unskidded machinery without proper lifting bars or hooks. The advance receiving warehouse cannot receive uncrated shipments.

Step 1. Review Freight Material Handling Rates and Information

NEW for 2016: GES is offering a 20% discount on any additional freight you bring to this year's show over and above your total 2015 show weight. For example, if your 2015 total was 10,000 lbs. and your 2016 weight is 15,000 lbs., the 20% discount will apply to the additional 5,000 lbs. The discount will be reflected under your material handling charges on your final show invoice.

Advance Shipment to Warehouse (200 lbs. minimum per shipment)

	Crated	Special Handling	Advance Shipments to Warehouse Dates:
Rate	\$81.50 cwt	\$100.25 cwt	Mon, Oct 10, 2016: Advance shipments may begin arriving at warehouse. Tue, Nov 1, 2016: Last day for shipments to arrive at warehouse.

Direct Shipment to Show Site (200 lbs. minimum per shipment)

	Crated	Special Handling	Uncrated	Direct Shipments to Show site Dates:
Rate	\$77.00 cwt	\$94.71 cwt	\$115.50 cwt	Tue, Nov 8, 2016: Direct shipments may begin arriving at exhibit site after 9:00 AM. Tue, Nov 8, 2016: Last day for shipments to arrive at exhibit site by 11:59 PM.

Small Package

Cartons and envelopes received without documentation will be delivered without guarantee of piece count or condition. Maximum weight is 50 lbs. for the first shipment, per delivery. This includes UPS and Federal Express shipments. All shipments received via air carrier that do not fall under the small package category may be subject to special handling charges. First shipment of small packages will be charged \$49.00. Each Additional Package will be charged \$24.45.

Step 2. Estimate Order

Small Packages

1st Small Package Shipment x \$49.00 = Total
 # of Additional packages (each) x \$24.45 = Total

Form Continues on Next Page



CWT 061600445 101116 R-2 082216 Cstm

Material Handling/Drayage Order Form

All orders are governed by the GES Payment Policy and GES Terms & Conditions of Contract as specified in this Exhibitor Services Manual.

Company Name _____ Email _____ Phone Number _____

Material Handling/Drayage

Calculate Total CWT (Enter in increments of 100's only; round up to the next 100 mark if your weight is more than 8 lbs. over the previous 100 mark. 200 pound minimum per shipment.). We understand that your calculation is only an estimate. Invoicing will be done from the actual weight. Adjustments will be made accordingly.

_____ pounds of freight ÷ 100 = _____ Total CWT x _____ Rate = _____ Total
_____ Grand Total

On Date: _____
By Carrier: _____
Total Number of Pieces: _____

Shipment Will Be Sent To:
 Exhibit Site Warehouse

Total and Sign: Return to Fax: 866.329.1437 • International Fax: 702.263.1520

Please Sign

X _____
Authorized Signature

_____ Date
Authorized Name - Please Print

I agree in placing this order that I have accepted GES Payment Policy and GES Terms & Conditions of Contract, including authorization for GES to retain personal information to better serve my need for GES services at future events.

Total Payment Enclosed

\$ _____

Surcharges

Late/Early to Warehouse Shipment Surcharges:

A 30% (\$50.00 minimum) surcharge will apply to all shipments received after the published timeline. Monthly Storage fee of _____ per cwt will apply before published timeline.

Special Handling/Mixed Shipments:

A 23% surcharge will apply to items requiring special handling or mixed shipments.

Measure of Damage:

If found liable for any loss, GES' sole and exclusive maximum liability for loss or damage to Customer's goods is limited to \$.50 (USD) per pound with a maximum liability of \$100 (USD) per container, or \$1,500.00 (USD) per shipment, whichever is less.

Certified Weight Tickets Are Required For All Shipments:

Drivers with inbound shipments must check in at the GES warehouse or exhibit site by 2:00 PM to be guaranteed same day unloading. Warehouse receiving hours are Monday - Friday, 7:30 AM - 3:30 PM; Closed 12:00 PM - 1:00 PM and Holidays.

CWT

101116 061600445

R-2 042816



What is "Special" Handling?

Special Handling applies to shipments that are loaded in such a manner as to require additional labor and handling to unload or load out. An additional fee beyond the standard crated rate will apply.

Special Handling Includes:

Ground Loading

- Vehicles that are not dock height, preventing the use of loading docks.
- When docks are not readily available.
- When convention facility has no dock space

Side Door Loading

- Shipments tendered for delivery in such a manner as to prevent access from the rear of the trailer.

Constricted Space Loading

- Freight loaded "high and tight" or down one side as to make shipments not readily available.

Designated Piece Loading

- When a trailer must be loaded in a particular sequence to ensure fit.

Stacked, Cubed-out, or Loose Shipments

- Shipments loaded in such a manner requiring items to be removed to ground level for delivery to booth.
- Items that would need to be unstacked/stacked, unstrapped/strapped, or loadbars to be removed/installed during the unload or load out process.

Multiple Shipments

- Shipments that are loaded mixed on the truck, failing to maintain shipment integrity and/or have multiple delivery areas.

Mixed Shipments

- Pieces for separate shipments that are loaded mixed throughout the delivery vehicle, or shipments of crated and uncrated goods where the percentage of uncrated is minimal and does not warrant full uncrated rate for shipment.

Improper Delivery Receipts

- Shipments that arrive without individual Bill of Lading. Possible examples might include: UPS, FedEx, company trucks, privately-owned vehicles.

Uncrated Shipments

- Material that is shipped loose or pad-wrapped, and/or unskidded machinery without proper lifting bars or hooks.

Special Handling Examples:



Side Door Loading

Constricted Space Loading



Stacked Shipments

Uncrated Shipment



Multiple Shipments

Use these shipping labels as they will expedite handling. Copies of these labels are acceptable if additional labels are needed.



FROM:



FROM:

Please print this label on a color printer if possible



TO:

Full Exhibiting Company Name at Show

Seattle International Auto Show

Name of Exhibition 0610600445

BOOTH NUMBER

C/O GES
4060 Lind Avenue SW
Renton, WA 98057 USA

Shipment Should Arrive on or Between:
Monday, Oct 10, 2016 - Tuesday, Nov 1, 2016

Certified Weight Tickets are required for all Shipments. Drivers must check in by 2:00 PM to be guaranteed same day unloading. Warehouse receiving hours are Monday - Friday, 7:30 AM - 3:30 PM; Closed 12:00 PM - 1:00 PM & Holidays.

Carrier _____
Number _____ of _____ pieces



TO:

Full Exhibiting Company Name at Show

Seattle International Auto Show

Name of Exhibition 0610600445

BOOTH NUMBER

C/O GES
4060 Lind Avenue SW
Renton, WA 98057 USA

Shipment Should Arrive on or Between:
Monday, Oct 10, 2016 - Tuesday, Nov 1, 2016

Certified Weight Tickets are required for all Shipments. Drivers must check in by 2:00 PM to be guaranteed same day unloading. Warehouse receiving hours are Monday - Friday, 7:30 AM - 3:30 PM; Closed 12:00 PM - 1:00 PM & Holidays.

Carrier _____
Number _____ of _____ pieces



Please print this label on a color printer if possible

Use these shipping labels as they will expedite handling. Copies of these labels are acceptable if additional labels are needed.



FROM:



FROM:

Please print this label on a color printer if possible



TO:

Full Exhibiting Company Name at Show

Seattle International Auto Show

Name of Exhibition 0610600445

BOOTH NUMBER

C/O GES
CenturyLink Field Event Center
1000 Occidental Avenue South
Seattle, WA 98134-1245 USA

Shipment Should Arrive Only On:

Tuesday, Nov 8, 2016 9:00 AM - 11:59 PM

Certified Weight Tickets are Required for all shipments. Drivers must check in by 2:00 PM to be guaranteed same day unloading.

Carrier _____
Number _____ of _____ pieces



TO:

Full Exhibiting Company Name at Show

Seattle International Auto Show

Name of Exhibition 0610600445

BOOTH NUMBER

C/O GES
CenturyLink Field Event Center
1000 Occidental Avenue South
Seattle, WA 98134-1245 USA

Shipment Should Arrive Only On:

Tuesday, Nov 8, 2016 9:00 AM - 11:59 PM

Certified Weight Tickets are Required for all shipments. Drivers must check in by 2:00 PM to be guaranteed same day unloading.

Carrier _____
Number _____ of _____ pieces



Please print this label on a color printer if possible

Request for Pre-Printed Outbound Material Handling Release/Labels

All orders are governed by the GES Payment Policy and GES Terms & Conditions of Contract as specified in this Exhibitor Services Manual.

Seattle International Auto Show
CenturyLink Field Event Center
November 10 - 13, 2016

Form Deadline Date:
October 21, 2016



Form Tips:

- This form is used to gather your shipping information for the destination of your freight after the show closes. This document is not a Bill of Lading (BOL).
- Save time checking out by completing this form for pre-printed outbound Material Handling documents and outbound address labels.
- In order to provide this service, please submit this form by October 21, 2016.
- Want an easier way? Fill out this information online and submit:
<https://e.ges.com/061600445/prePrint/esm>

Step 1. Tell us the location of materials for pickup (show site address)

Company/Consignee	Attention			
1000 Occidental Avenue South	Seattle	WA	98134-1245	USA
Street Address	City	State	Zip/Postal Code	Country
Phone	Fax		Booth Number	

Step 2. Tell us the location where freight should be sent

Shipping Destination 1:

Number of Labels Needed:

Company/Consignee	Attention			
Street Address	City	State	Zip/Postal Code	Country
Phone	Fax		Booth Number	

Shipping Destination 2:

Number of Labels Needed:

Company/Consignee	Attention			
Street Address	City	State	Zip/Postal Code	Country
Phone	Fax		Booth Number	

Showsite Instructions: Once your shipment is packed and ready to be picked up, please return the outbound material handling release form to the GES Servicercenter®. Verify the piece count, weight, and that the signature is on the outbound material handling release form prior to shipping out. Shipments without paperwork turned in will be returned to GES Warehouse or forced onto another carrier at Exhibitor's expense.

GES does not accept responsibility for any exhibitor property left on the show floor unattended at any time for any reason.

Measure of Damage: If found liable for any loss, GES' sole and exclusive maximum liability for loss or damage to Customer's Goods is limited to \$.50 (USD) per pound with a maximum liability of \$100.00 (USD) per container, or \$1,500.00 (USD) per shipment, whichever is less.

Review and Return: Return to Fax: 866.329.1437 • International Fax: 702.263.1520

101116 061600445
R-3 042716



Freight Service Questionnaire

All orders are governed by the GES Payment Policy and GES Terms & Conditions of Contract as specified in this Exhibitor Services Manual.

Seattle International Auto Show
CenturyLink Field Event Center
November 10 - 13, 2016

Form Deadline Date:
October 21, 2016

Company Name

Email

Phone Number

Booth Number



Required Information For Exhibitors with Freight Shipments:

- This form should be returned by all exhibitors shipping freight.
- By returning this form we can better plan and prepare for incoming freight.
- Want an easier way? Fill out this information online and submit:
<http://e.ges.com/061600445/freightQuestionnaire/esm>

1. Estimate total number of pieces being shipped:

_____ Crated
_____ Uncrated
_____ Machinery
_____ Total

2. Indicate total number of trucks in each category that you will use:

_____ Van Line
_____ Common Carrier
_____ Flatbed
_____ Co. Truck
_____ Overseas Container

3 List carrier name(s):

4. If using a Customs Broker, please print name:

Phone Number:

5. Print the name of person in charge of your move-in:

Phone Number:

6. What is the minimum number of days to set your display?

7. What is the weight of the single heaviest piece that must be lifted?

_____ lbs.

8. What is the total weight of your exhibit or equipment being shipped?

_____ lbs.

9. Is there any special handling equipment required to unload your exhibit materials, i.e. extended forklift blades, special slings, lifting bars. etc.?

It is the responsibility of the exhibitor to provide proper special handling instructions, and to ensure goods are packaged appropriately for shipment and movement by heavy equipment. Failure to provide special handling instructions will result in the elimination of any liability for loss or damage by GES.

Direct Shipments Only

1. What date and time are you scheduling your shipment(s) to arrive on-site?

Review and Return: Return to Fax: 866.329.1437 • International Fax: 702.263.1520

Marshaling Yard and Direct Deliveries Information

All orders are governed by the GES Payment Policy and GES Terms & Conditions of Contract as specified in this Exhibitor Services Manual.

Seattle International Auto Show
CenturyLink Field Event Center
November 10 - 13, 2016

Tips For New Exhibitors



Tips

What is a marshaling yard? The Marshaling Yard is an offsite location where trucks are checked in and held until dock space for unloading becomes available onsite.

Why is a marshaling yard used? Large shows use a marshaling yard to ease vehicle congestion and to ensure the unloading process runs smoothly.

Savings



Save

- There is no charge for this Marshaling Yard service.
- Avoid late charges by checking the Show Schedule for arrival dates and times.

Marshaling Yard Site Address:

c/o GES
Seattle International Auto Show
(Your Company Name & Booth Number)
700 Occidental Ave. South
Seattle, WA 98104
USA

Marshaling Yard Process

It is important that you advise your carrier of this Marshaling Yard information to better facilitate your direct shipment to showsite.

- All delivering carriers and privately owned vehicles must check in at the Marshaling Yard prior to show site deliveries. All inbound shipments will be weighed at the Marshaling Yard to obtain the gross or heavy weight.
- All inbound shipments must be accompanied by a certified weight certificate and Bill of Lading.
- At the Marshaling Yard, drivers will be assigned a number and will be dispatched to the appropriate dock at CenturyLink Field Event Center as space is available. Waiting time at the Marshaling Yard should be anticipated by your carrier. Every effort is made to keep this waiting time at a minimum. However, the waiting time depends on many factors, including the number of vehicles arriving to unload/load, the type of loads being unloaded at the CenturyLink Field Event Center, the number of booths on a truck, etc.
- After unloading, all vehicles must return to the Marshaling Yard with a completed copy of the GES Receiving Report to be weighed to obtain the light weight. This determines the total weight of your shipment. Drivers who fail to return to weigh-out may face having their shipment billed at the heavy weight.
- All drivers are expected to adhere to GES' policies and procedures with respect to the loading and unloading of trailers.

Contact us for Assistance with your Inbound Freight Arrangements



Contact

- Chat with us <http://www.ges.com/chat>
- Contact us online: <https://e.ges.com/061600445/contactus/esm>

061600445
101116

R-9 031616

Seattle Auto Show Move-in Routes

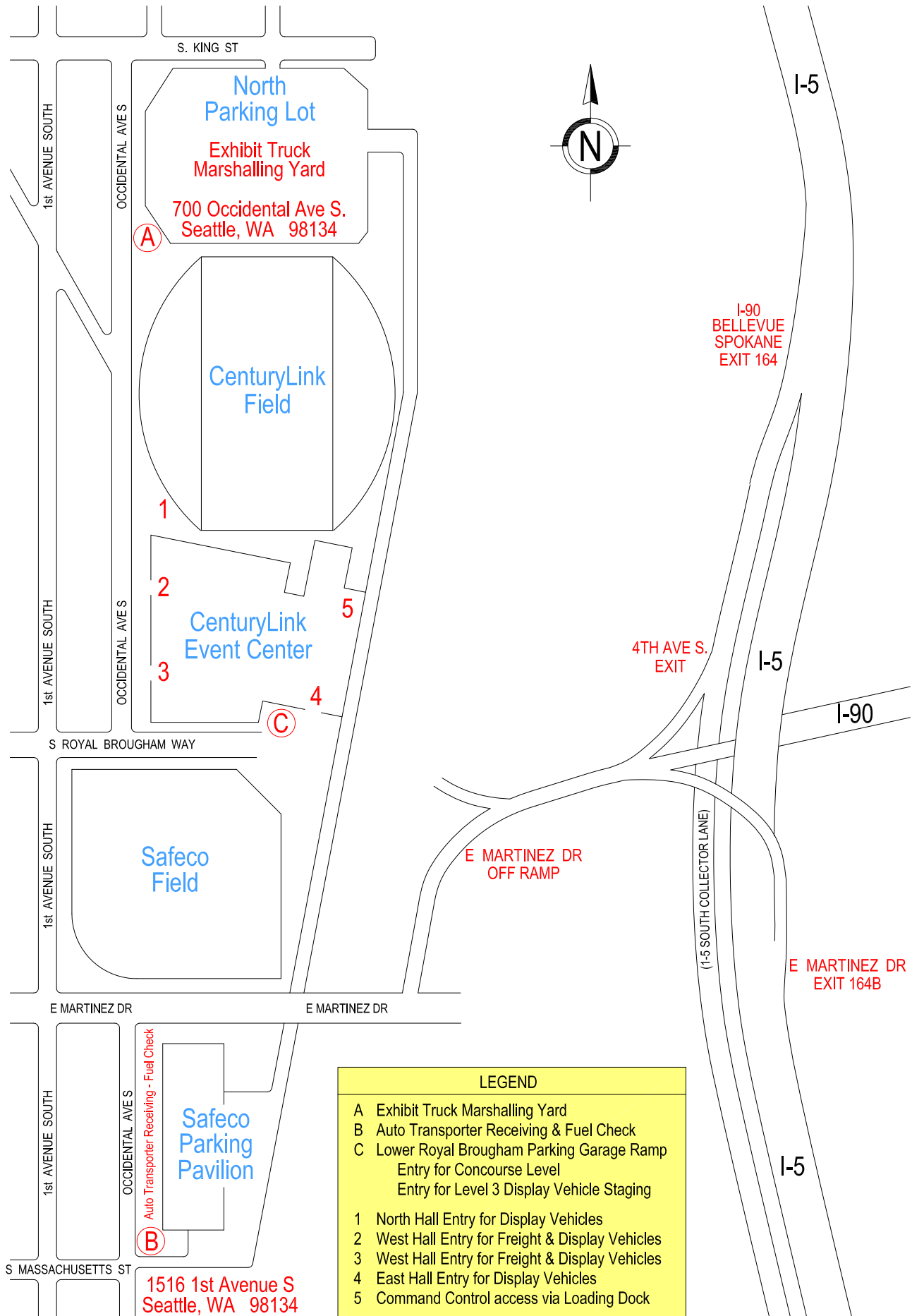

LEGEND	
A	Exhibit Truck Marshalling Yard
B	Auto Transporter Receiving & Fuel Check
C	Lower Royal Brougham Parking Garage Ramp
	Entry for Concourse Level
	Entry for Level 3 Display Vehicle Staging
1	North Hall Entry for Display Vehicles
2	West Hall Entry for Freight & Display Vehicles
3	West Hall Entry for Freight & Display Vehicles
4	East Hall Entry for Display Vehicles
5	Command Control access via Loading Dock

Show Site Storage Order Form

All orders are governed by the GES Payment Policy and GES Terms & Conditions of Contract as specified in this Exhibitor Services Manual.

Seattle International Auto Show
 CenturyLink Field Event Center
 November 10 - 13, 2016

Discount Deadline Date:
 October 21, 2016

Company Name _____ Email _____ Phone Number _____ Booth Number _____



Easy Ordering Tips:

- An authorized company representative must be present at the time of delivery to your booth to inventory the items and to sign for receipt of items. Delivery hours may be restricted, check with the representatives in the GES Servicenter. An advance deposit is required to guarantee storage reservations.
- Straight Time: Monday through Friday from 8:00 AM to 4:30 PM.
- Overtime: All other times Monday through Friday. All day Saturday, Sunday & Holidays.

Step 1. Order Access Storage

Skid Access Storage

- A storage area will be available for Exhibitor's literature and samples not requiring refrigeration.
- The charge for storage as described will be per skid, one skid minimum. This charge includes one time delivery to storage area and delivery from storage to booth after the close of the show. Maximum size per single item is not to exceed 48" x 48" x 72."
- When ready for delivery of material to or from storage, please notify the GES Servicenter.
- Standard labor rates apply for each delivery to the booth, or return of material to storage. Access storage is not secured storage. All items are stored at Exhibitor's sole risk.
- Refer to Labor Information and Regulations form for additional requirements.

Item Code	Description	Rate (\$)	Qty	Total
200513	Access Storage, Per Pallet/Piece	78.75		\$

Additional Delivery Rates

Item Code	Description	Discount (\$)	Regular (\$)	Show Site (\$)	X # Workers	X # Hours	Tax %	=	Total
705044	Storage, ST	71.50	106.00	127.25			9.6	\$	
705044	Storage, OT	125.00	185.50	222.50			9.6	\$	

Hate math? Let Espresso calculate your rates: <https://e.ges.com/061600445/labor/esm>

Step 2. Schedule Additional Deliveries

Invoice will be calculated according to actual hours worked. Additional labor required will be calculated and invoiced at the show site rate.

Schedule Dates	Schedule Start Time	Schedule End Time	Schedule Dates	Schedule Start Time	Schedule End Time	Schedule Dates	Schedule Start Time	Schedule End Time
MM/DD/YR	AM PM	AM PM	MM/DD/YR	AM PM	AM PM	MM/DD/YR	AM PM	AM PM
MM/DD/YR	AM PM	AM PM	MM/DD/YR	AM PM	AM PM	MM/DD/YR	AM PM	AM PM

Rates and Information for Storage Deliveries Requiring Equipment

- Order forklifts for heavy items or pallets of materials from storage.
- Notice of Delivery – Arrangements, in the form of a work order, must be made by 2:00 PM the day prior to delivery. The work order must be placed at the GES Servicenter. All remaining materials in accessible storage will be returned to the booth after show close (delivery charges will apply).
- Refer to Labor Information and Regulations form for additional requirements.
- Straight Time: Monday through Friday from 8:00 AM to 4:30 PM.
- Overtime: All other times Monday through Friday. All day Saturday, Sunday & Holidays.

Item Code	Description	Discount (\$)	Regular (\$)	Show Site (\$)	X # Crews	X # Hours	Tax %	=	Total
705200	5,000#, ST	130.75	163.25	196.00			9.6	\$	
705200	5,000#, OT	183.25	228.75	274.00			9.6	\$	

Hate math? Let Espresso calculate your rates: <https://e.ges.com/061600445/labor/esm>

Form Continues on Next Page



R-11/R-12 052316 101116 061600445

Show Site Storage Order Form

All orders are governed by the GES Payment Policy and GES Terms & Conditions of Contract as specified in this Exhibitor Services Manual.

Discount Deadline Date:
October 21, 2016

Company Name _____ Email _____ Phone Number _____ Booth Number _____

Step 3. Schedule Forklift for Storage Deliveries

Invoice will be calculated according to actual hours worked. Additional labor required will be calculated and invoiced at the show site rate.

Schedule Dates	Schedule Start Time	Schedule End Time	Schedule Dates	Schedule Start Time	Schedule End Time	Schedule Dates	Schedule Start Time	Schedule End Time
MM/DD/YR	AM PM	AM PM	MM/DD/YR	AM PM	AM PM	MM/DD/YR	AM PM	AM PM
MM/DD/YR	AM PM	AM PM	MM/DD/YR	AM PM	AM PM	MM/DD/YR	AM PM	AM PM

Total and Sign: Return to Fax: 866.329.1437 • International Fax: 702.263.1520

Please Sign

X

Authorized Signature

Authorized Name - Please Print Date

I agree in placing this order that I have accepted GES Payment Policy and GES Terms & Conditions of Contract, including authorization for GES to retain personal information to better serve my need for GES services at future events.

Total Payment Enclosed

\$

Cartload Service Order Form

All orders are governed by the GES Payment Policy and GES Terms & Conditions of Contract as specified in this Exhibitor Services Manual.

Seattle International Auto Show
 CenturyLink Field Event Center
 November 10 - 13, 2016

Form Deadline Date:
 October 21, 2016

Company Name _____ Email _____ Phone Number _____ Booth Number _____

Vehicles That Qualify for Cartload - Under One (1) Ton



Sedan



Van



SUV



Small Pickup

Important Reminders

-  **Reminder**
- Maximum Weight 200 lbs to qualify for this service.
- Freight that is too large or heavy will be charged Material Handling rates
- One (1) round trip allowed per booth.

Cartload Freight Services for Unloading Small Passenger Vehicles

- To facilitate the move-in and move-out of Exhibitors with small exhibit material shipments, cartload service is available for one (1) laborer with one (1) pushcart, for one (1) round trip.
- This service is for those who have small hand carry items all of which must fit on a 2' x 6' push cart for one (1) round trip. If you arrive with a truck or van (one 1-ton and over), trailer, or truck with trailer filled with exhibit material you will not qualify for this service and will be redirected.
- A cartload is eight (8) pieces or less, weighing less than 200 lbs. total. one (1) round trip allowed per booth.
- Your vehicle must unload on the receiving dock of the exhibit hall. GES personnel will direct vehicles. The cart is not authorized to enter or go to any parking structure. There must be two (2) people with the vehicle; one person to go with your product to the booth space and one person to remove your vehicle from the unloading area to the parking area.
- Freight that is too large or heavy will be charged Material Handling/Drayage rates. No personal trucks (one 1-ton and over), no rental trucks, trailers or bobtails will be unloaded through cartload service.
- To receive this service, go to the Marshaling Yard and watch for the Cartload Service signs.
- Pre-orders will receive preferential service at show site, you may also order this service at the GES Servicenter.

Cartload Services

Item Code	Description	Rate (\$)	# of Trips	Total
200506	Cartload Service, Straight Time	50.00	1	\$
200506	Cartload Service, Over Time	50.00	1	\$

Total and Sign: Return to Fax: 866.329.1437 • International Fax: 702.263.1520

Please Sign

X

Authorized Signature

Authorized Name - Please Print

Date

I agree in placing this order that I have accepted GES Payment Policy and GES Terms & Conditions of Contract, including authorization for GES to retain personal information to better serve my need for GES services at future events.

Total Payment Enclosed

\$

061600445

101116

R-14 092316

Labor Information and Regulations

All orders are governed by the GES Payment Policy and GES Terms & Conditions of Contract as specified in this Exhibitor Services Manual.

Seattle International Auto Show
CenturyLink Field Event Center
November 10 - 13, 2016

Save on Labor Costs



- Save money by pre-ordering labor.
- Don't forget to order labor for move-out.
- Return your orders before the discount deadline to receive the best price.
- Return your booth layout diagram. It could save you money by averting labor costs to move heavy items at show site.

Important Information

Starting time can be guaranteed only when labor is requested for the start of the working day. All exhibit labor scheduled at the start of the working day will be dispatched to booth space. For all other starting times, check in at the labor desk one-half (½) hour before time requested. Labor cancelled without a 24 hour notice shall be charged a one (1) hour cancellation fee per worker. If Exhibitor fails to use the workers at the time confirmed, a one (1) hour "No-Show" charge per worker will apply.

The minimum charge for labor is one (1) hour per worker. Labor thereafter is charged in half (½) hour increments. Gratuities in any form, including cash, gifts, or labor hours for work not actually performed are prohibited by GES. GES requires the highest standards of integrity from all employees. Please call our confidential Always Honest hotline at 866.225.8230 to report fraudulent or unethical behavior. All rates are subject to change if necessitated by increased labor and material costs.

Trade Labor Descriptions

Below are information and rates for the labor types offered in this show. These workers may be ordered with equipment on other forms. The rates listed below are for your information and planning only. See the included order forms for scheduling and estimating your labor costs.

Installation and Dismantle

Responsible for uncrating, installation, and dismantle of exhibits, laying of carpet and tile, recreating of exhibits, and closing of machinery crates.

705000 : Installation and Dismantle	Discount Orders placed on or before Oct 21	Regular Orders Placed Oct 22 thru Nov 7	Show Site Rate Increases on Nov 8
Straight Time: Monday through Friday from 8:00 AM to 4:30 PM.	\$ 71.50	\$ 106.00	\$ 127.25
Overtime: All other times Monday through Friday. All day Saturday, Sunday & Holidays.	\$ 125.25	\$ 185.50	\$ 222.50

Freight

Responsible for handling freight in and out of the hall. For safety reasons additional workers may be assigned to the crew.

705030 : Additional Worker, Freight	Discount Orders placed on or before Oct 21	Regular Orders Placed Oct 22 thru Nov 7	Show Site Rate Increases on Nov 8
Straight Time: Monday through Friday from 8:00 AM to 4:30 PM.	\$ 71.50	\$ 106.00	\$ 127.25
Overtime: All other times Monday through Friday. All day Saturday, Sunday & Holidays.	\$ 125.00	\$ 185.50	\$ 222.50

Storage

Responsible for deliveries from Storage areas to the booth.

705044 : Storage	Discount Orders placed on or before Oct 21	Regular Orders Placed Oct 22 thru Nov 7	Show Site Rate Increases on Nov 8
Straight Time: Monday through Friday from 8:00 AM to 4:30 PM.	\$ 71.50	\$ 106.00	\$ 127.25
Overtime: All other times Monday through Friday. All day Saturday, Sunday & Holidays.	\$ 125.00	\$ 185.50	\$ 222.50

101116 061600445

L-0 091416

Installation and Dismantling Order Form

All orders are governed by the GES Payment Policy and GES Terms & Conditions of Contract as specified in this Exhibitor Services Manual.

Seattle International Auto Show
 CenturyLink Field Event Center
 November 10 - 13, 2016

Discount Deadline Date:
 October 21, 2016

Company Name _____ Email _____ Phone Number _____ Booth Number _____



Easy Ordering Tips:

- Please complete this form for all display labor needed. To determine if you need display labor, please read the show site work rules carefully.
- Exhibitor may set up exhibit display if one person can accomplish the task in less than one-half (½) hour without the use of tools.
- Exhibitor may unpack and place merchandise.
- Don't forget to order labor for Move In and Move Out.
- Straight Time (ST): Monday through Friday from 8:00 AM to 4:30 PM.
- Overtime (OT): All other times Monday through Friday. All day Saturday, Sunday & Holidays.

Step 1. Order Labor

Item Code	Description	Discount (\$)	Regular (\$)	Show Site (\$)	X # Workers	X # Hours	Tax %	=	Total
705000	Install & Dismantle, ST Move In	71.50	106.00	127.25			9.6	\$	
705000	Install & Dismantle, ST Move Out	71.50	106.00	127.25			9.6	\$	
705000	Install & Dismantle, OT Move In	125.25	185.50	222.50			9.6	\$	
705000	Install & Dismantle, OT Move Out	125.25	185.50	222.50			9.6	\$	

Hate math? Let Espresso calculate your rates: <https://e.ges.com/061600445/labor/esm>

Step 2. Please Indicate Service



What is GES Supervision? An exhibitor chooses GES Supervised when they do not want to be present when the work is completed. On most shows and services, there is a minimum surcharge for the professional supervision. Remember, when a an exhibitor chooses this option, they do not need to schedule a date and time for services to be completed.

Option 1 (A 30% (\$ 50.00 minimum) surcharge will be added)

GES Supervised (OK to proceed without exhibitor.)

Please complete Key Information form, click here: <https://e.ges.com/061600445/laborchecklist/esm>
 GES will supervise labor to:

- Unpack and install display before Exhibitor arrival at show site.
- Dismantle and pack the display after show closing.

- Subject to terms and conditions of all GES policies, including terms and conditions of contract, including but not limited to sub-paragraph VII, b., Labor.
- A 30% (\$ 50.00 minimum) surcharge will be added to the labor rates above for this professional supervision.

Location of Booth/Dimension of Booth: Use the Booth Layout Form to represent your booth, indicate from each boundary how you would like your booth placed.

101116 061600445

L-1 100416

Form Continues on Next Page



Installation and Dismantling Order Form

All orders are governed by the GES Payment Policy and GES Terms & Conditions of Contract as specified in this Exhibitor Services Manual.

Company Name _____ Email _____ Phone Number _____ Booth Number _____



What is Exhibitor Supervision? An exhibitor chooses Exhibitor Supervised so they are able to instruct the laborer. The exhibitor is required to be in the booth and there are no supervision fees. Scheduling a date and time is necessary for this choice.

Option 2

- Exhibitor Supervised
 - Indicate workers needed for installation and dismantling
 - GES assumes no liability for loss, damage or bodily injury arising out of the installation and/or dismantling of Exhibitor's property by GES provided union labor. Exhibitor assumes the responsibility and any liability arising therefrom, for the work performed by union labor under Exhibitor's supervision. Exhibitors must stay clear during movement of freight.

GES is responsible for the following type of booth:

- Pop-Up Two Story Custom
- Other: _____

Please estimate the number of workers and hours per worker needed for installation. Invoice will be calculated according to actual hours worked, relative to the original estimate and based upon the date received. Additional labor required will be calculated and invoiced at the show site rate.

Move In

Schedule Dates	Schedule Start Time	Schedule End Time	Number of Workers
MM/DD/YR	AM PM	AM PM	
MM/DD/YR	AM PM	AM PM	
MM/DD/YR	AM PM	AM PM	

Move Out

Schedule Dates	Schedule Start Time	Schedule End Time	Number of Workers
MM/DD/YR	AM PM	AM PM	
MM/DD/YR	AM PM	AM PM	
MM/DD/YR	AM PM	AM PM	

Important Information

Starting time can be guaranteed only when labor is requested for the start of the working day. All exhibit labor scheduled at the start of the working day will be dispatched to booth space. For all other starting times, check in at the labor desk one-half (½) hour before time requested. Labor cancelled without a 24 hour notice shall be charged a one (1) hour cancellation fee per worker. If Exhibitor fails to use the workers at the time confirmed, a one (1) hour "No-Show" charge per worker will apply.

The minimum charge for labor is one (1) hour per worker. Labor thereafter is charged in half (½) hour increments. Gratuities in any form, including cash, gifts, or labor hours for work not actually performed are prohibited by GES. GES requires the highest standards of integrity from all employees. Please call our confidential Always Honest hotline at 866.225.8230 to report fraudulent or unethical behavior. All rates are subject to change if necessitated by increased labor and material costs.

Total and Sign: Return to Fax: 866.329.1437 • International Fax: 702.263.1520



X _____
Authorized Signature

Authorized Name - Please Print Date

I agree in placing this order that I have accepted GES Payment Policy and GES Terms & Conditions of Contract, including authorization for GES to retain personal information to better serve my need for GES services at future events.

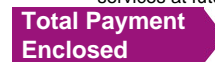

\$

061600445

L-1 100416



Forklift Order Form

All orders are governed by the GES Payment Policy and GES Terms & Conditions of Contract as specified in this Exhibitor Services Manual.

Seattle International Auto Show
 CenturyLink Field Event Center
 November 10 - 13, 2016

Discount Deadline Date:
 October 21, 2016

Company Name	Email	Phone Number	Booth Number
Show Site Contact	Show Site Email	Show Site Phone Number	



Easy Ordering Tips:

- In-booth forklift and labor may be required to assemble displays or when uncrating, positioning, and reskidding equipment and machinery.
- A forklift is required for moving equipment and materials weighing 200 pounds or more.
- If you require a forklift, a crew will be assigned consisting of a forklift with an operator.
- Please see Labor Information form for additional requirements regarding labor.
- Don't forget to order labor for Move In and Move Out.
- Straight Time (ST): Monday through Friday from 8:00 AM to 4:30 PM.
- Overtime (OT): All other times Monday through Friday. All day Saturday, Sunday & Holidays.

Step 1. Order Labor

Forklift with Operator, Per Hour

Item Code	Description	Discount (\$)	Regular (\$)	Show Site (\$)	X # Crews	X # Hours	Tax %	=	Total
705200	5,000#, ST Move In	130.75	163.25	196.00			9.6	\$	
705200	5,000#, ST Move Out	130.75	163.25	196.00			9.6	\$	
705200	5,000#, OT Move In	183.25	228.75	274.00			9.6	\$	
705200	5,000#, OT Move Out	183.25	228.75	274.00			9.6	\$	

Forklift 4-Stage with Operator, Per Hour

Item Code	Description	Discount (\$)	Regular (\$)	Show Site (\$)	X # Crews	X # Hours	Tax %	=	Total
705240	5,000#, ST Move In	163.50	204.25	245.00			9.6	\$	
705240	5,000#, ST Move Out	163.50	204.25	245.00			9.6	\$	
705240	5,000#, OT Move In	229.25	285.75	342.50			9.6	\$	
705240	5,000#, OT Move Out	229.25	285.75	342.50			9.6	\$	

Additional Worker, Freight, Per Hour

Item Code	Description	Discount (\$)	Regular (\$)	Show Site (\$)	X # Crews	X # Hours	Tax %	=	Total
705030	Freight, ST Move In	71.50	106.00	127.25			9.6	\$	
705030	Freight, ST Move Out	71.50	106.00	127.25			9.6	\$	
705030	Freight, OT Move In	125.00	185.50	222.50			9.6	\$	
705030	Freight, OT Move Out	125.00	185.50	222.50			9.6	\$	

Hate math? Let Espresso calculate your rates: <https://e.ges.com/061600445/labor/esm>

061600445
 101116
 T-1 072516



All orders are governed by the GES Payment Policy and GES Terms & Conditions of Contract as specified in this Exhibitor Services Manual.

Company Name _____ Email _____ Phone Number _____ Booth Number _____

Step 2. Labor Information



What is Exhibitor Supervision? An exhibitor chooses Exhibitor Supervised so they are able to instruct the laborer. The exhibitor is required to be in the booth and there are no supervision fees. Scheduling a date and time is necessary for this choice.

- Exhibitor Supervised (Do Not Proceed)
- Exhibitor will supervise.
- Indicate workers needed for installation and dismantling
 - GES assumes no liability for loss, damage or bodily injury arising out of the installation and/or dismantling of Exhibitor's property by GES provided union labor. Exhibitor assumes the responsibility and any liability arising therefrom, for the work performed by union labor under Exhibitor's supervision. Exhibitors must stay clear during movement of freight.

- GES is responsible for the following type(s) of work:
- Uncrating Unskidding Positioning
 Leveling Dismantling Recrating
 Reskidding
- Additional labor will be assigned if necessary.

Step 3. Schedule In Booth Forklift Labor

Starting time can be guaranteed only when labor is requested for the start of the working day. All exhibit labor scheduled at the start of the working day will be dispatched to booth space. Confirm labor and forklifts by 2:30 PM the day before date requested. Please have a representative pick up the crew at the labor desk and supervise the work to be done. Upon completion, the Exhibitor's representative will return the crew to the labor desk and approve the work order. Equipment and labor cancelled without a 24 hour notice shall be charged a one (1) hour cancellation fee per worker and forklift. If Exhibitor fails to use the workers and equipment at the time confirmed, a one (1) hour cancellation fee per worker and forklift will apply.

The minimum charge for labor is one (1) hour per worker and equipment. Labor thereafter is charged in half (½) hour increments per worker and equipment. Gratuities in any form, including cash, gifts, or labor hours for work not actually performed are prohibited by GES. GES requires the highest standards of integrity from all employees. Please call our confidential Always Honest hotline at 866.225.8230 to report fraudulent or unethical behavior. All rates are subject to change if necessitated by increased labor and material costs.

Please estimate the number of workers and hours per worker needed for installation. Invoice will be calculated according to actual hours worked, relative to the original estimate and based upon the date received. Additional labor required will be calculated and invoiced at the show site rate.

Move In

Schedule Dates	Schedule Start Time	Schedule End Time	Number of Lifts/Workers
MM/DD/YR	AM PM	AM PM	
MM/DD/YR	AM PM	AM PM	

Schedule Dates	Schedule Start Time	Schedule End Time	Number of Lifts/Workers
MM/DD/YR	AM PM	AM PM	
MM/DD/YR	AM PM	AM PM	

Move Out

Schedule Dates	Schedule Start Time	Schedule End Time	Number of Lifts/Workers
MM/DD/YR	AM PM	AM PM	
MM/DD/YR	AM PM	AM PM	

Schedule Dates	Schedule Start Time	Schedule End Time	Number of Lifts/Workers
MM/DD/YR	AM PM	AM PM	
MM/DD/YR	AM PM	AM PM	

Total and Sign: Return to Fax: 866.329.1437 • International Fax: 702.263.1520

Please Sign

X

Authorized Signature

Authorized Name - Please Print

Date

I agree in placing this order that I have accepted GES Payment Policy and GES Terms & Conditions of Contract, including authorization for GES to retain personal information to better serve my need for GES services at future events.

Total Payment Enclosed

\$

101116 061600445

T-1 072516



Hanging Sign / Truss Labor Information

All orders are governed by the GES Payment Policy and GES Terms & Conditions of Contract as specified in this Exhibitor Services Manual.

Seattle International Auto Show
CenturyLink Field Event Center
November 10 - 13, 2016

Please complete and return the Hanging Sign / Truss Labor Order Form by October 21, 2016.

By sending us this information in advance you will help us assure your sign is properly assembled and installed.



Reminder

Hanging Signs:

GES is responsible for assembly, installation, and removal of all hanging signs..

- All signs must be designed to comply with Show Organizer rules and regulations and facility limitations.
- Make sure all signs, with the exception of cloth banners and signs under 100 lbs., have structurally engineered rigging points as well as blueprints displaying a current structural engineer's stamp.
- If your sign requires electricity, make sure it is in working order and in accordance with the National Electric Code.
- Include Showsite Exhibitor contact information with the order.
- Include engineer-stamped drawings with hanging instructions as well as a set of assembly instructions (placement/orientation) with the order. GES accepts no liability for any work completed without such instructions, when required. Work is done at Exhibitor's risk and Exhibitor shall indemnify and defend GES and Show Organizer from any claims arising out of or related to the installation or dismantle of any sign without approved drawings.



Reminder

Truss and Hoists:

GES is responsible for assembly, installation, and removal of all truss.

- All truss must be designed to comply with Show Organizer rules and regulations as well as facility limitations.
- All truss must be from a recognized manufacturer. Manufacturer load specifications for your truss must be at show site prior to rigging.
- Climbing on truss is strictly prohibited.
- All lamps and fixtures to be attached to truss must be in good working order and in compliance with the National Electric Code.
- All hoists must be from a recognized manufacturer and must be in good working order.
- Hoist maintenance records should be available for inspection by GES.

Shipping Instructions

Please ship your hanging signs in advance. All hanging signs must be received in advance at the GES warehouse by November 1, 2016 to receive the Discount Price. Please ship all hanging signs in a separate container with the special sign label enclosed in this exhibitor services manual. Mark bills of lading "Hanging Sign." Prepay all shipments. Collect shipments will not be accepted. See Shipping Information and Shipping Guidelines for more information.

Please call for information on advance shipping for all uncrateable signs.

101116 061600445

H-1 011416

Hanging Sign / Truss Labor Order Form

All orders are governed by the GES Payment Policy and GES Terms & Conditions of Contract as specified in this Exhibitor Services Manual.

Seattle International Auto Show
 CenturyLink Field Event Center
 November 10 - 13, 2016

Discount Deadline Date:
 October 21, 2016

Company Name	Email	Phone Number	Booth Number
Show Site Contact	Show Site Email	Show Site Phone Number	



Easy Ordering Tips:

- A crew will be assigned consisting of a lift with two riggers for aerial work.
- Don't forget to order labor for Move In and Move Out.
- Straight Time (ST): Monday through Friday from 8:00 AM to 4:30 PM.
- Overtime (OT): All other times Monday through Friday. All day Saturday, Sunday & Holidays.

Step 1. Order Labor

Lift with Operator, Per Hour

Item Code	Description	Discount (\$)	Regular (\$)	Show Site (\$)	# Crews	# Hours	Tax %	Total
705300	High Lift, ST Move In	446.25	557.75	669.50			9.6	\$
705300	High Lift, ST Move Out	446.25	557.75	669.50			9.6	\$
705300	High Lift, OT Move In	557.75	697.00	836.50			9.6	\$
705300	High Lift, OT Move Out	557.75	697.00	836.50			9.6	\$
705301	Scissor Lift, ST Move In	446.25	557.75	669.50			9.6	\$
705301	Scissor Lift, ST Move Out	446.25	557.75	669.50			9.6	\$
705301	Scissor Lift, OT Move In	557.75	697.00	836.50			9.6	\$
705301	Scissor Lift, OT Move Out	557.75	697.00	836.50			9.6	\$

Sign Assembly (Non-Electrical)

Item Code	Description	Discount (\$)	Regular (\$)	Show Site (\$)	X # Workers	X # Hours	Tax %	= Total
705020	Sign Assembly, ST Move In Only	102.25	127.75	153.00			9.6	\$
705020	Sign Assembly, OT Move In Only	178.75	223.50	268.25			9.6	\$

Hate math? Let Espresso calculate your rates: <https://e.ges.com/061600445/labor/esm>



What is Exhibitor Supervision? An exhibitor chooses Exhibitor Supervised so they are able to instruct the laborer. The exhibitor is required to be in the booth and there are no supervision fees. Scheduling a date and time is necessary for this choice.

What is GES Supervision? An exhibitor chooses GES Supervised when they do not want to be present when the work is completed. On most shows and services, there is a minimum surcharge for the professional supervision. Remember, when an exhibitor chooses this option, they do not need to schedule a date and time for services to be completed.

101116 061600445
 H-2 080216

Form Continues on Next Page



All orders are governed by the GES Payment Policy and GES Terms & Conditions of Contract as specified in this Exhibitor Services Manual.

Discount Deadline Date:
October 21, 2016

Company Name _____ Email _____ Phone Number _____ Booth Number _____

Show Site Contact _____ Show Site Email _____ Show Site Phone Number _____

Step 2. Please Indicate Service Hanging Sign Options

How many signs will be hung in your booth?

(if there are multiple signs, please complete an order form for each sign and label 1 of 3, etc)

Type of Sign

- Banner Structural Signage
 Systems Moss

Dimensions and Weight of Sign

Width _____ Height _____
Length _____ Total Weight _____ lbs

Height

Number of feet from floor to top of sign:
_____ Feet
Must be compliant with Show Rules and Regulations.

Electrical

(Not provided by GES. These services must be ordered through the electrical service provider)

Is your sign electrical?
 Yes No

Shape of Sign

- Square Rectangle
 Triangle Circle
 Serpentine Other _____

Pick Points

Number of structural pick points _____
Weight at each pick point _____
Have you submitted your structurally engineered rigging points? _____
Dates Submitted _____

Assembly

Does your sign require assembly?
 Yes No
If yes, GES must assemble your sign prior to hanging. See Hanging Sign / Truss Labor Rate and Information.

Hoists

(Not provided by GES. These services must be ordered through the facility)

Are hoists required?
 Yes No
if yes, how many? _____
 Exhibitor Owned GES Rental

Supervision

Do you want to supervise the hanging of your sign?
 Yes No
If yes, schedule the date you would like the sign to be hung in Step 3 of this form.
Please provide GES with a contact name and number to discuss _____

If no, GES will supervise without exhibitor present.

- A 25% (\$50.00 minimum) surcharge will be added to the labor rates above for this professional supervision.
- Date and time not required. No need to complete Step 3. Proceed to Total and Sign.

If your Hanging Sign is received in the advance warehouse, and GES has all the required information, your Hanging Sign could possibly be hung prior to your arrival.

Location of Sign

Use the Booth Layout Form provided in the kit to represent your booth and indicate placement of your sign. Sign Orientation must be given by providing surrounding booth numbers.

101116 061600445

H-2 072616



All orders are governed by the GES Payment Policy and GES Terms & Conditions of Contract as specified in this Exhibitor Services Manual.

Discount Deadline Date:
October 21, 2016

Company Name	Email	Phone Number	Booth Number
Show Site Contact	Show Site Email	Show Site Phone Number	

Truss Options

Type of Truss

- Plated (end plates) Spigot

Size of Truss

- 12" 20.5"

Dimensions Truss Design

Width _____ Length _____
Total Truss/Lighting Weight _____ lbs

Height

Number of feet from floor to top of sign:
_____ Feet
Must be compliant with Show Rules and Regulations.

Electrical

Do you require an electrical drop to the truss?

- Yes No

How much power is required for the truss?

Please provide a diagram for electrical drop and placement with your order.

GES will automatically apply your power and labor to install the drop on your account. See Electrical Outlet and Labor Order Forms for rates.

Truss Attachments

- Audio Visual Equipment*
- Signage/Banners
- Static Lighting
- Dimmable/Programmable Lighting*

*Stagehand labor is required. Please refer to the Stagehand Labor Order Form.

Pick Points

Number of structural pick points _____

The weight, point loads and the load path to the ceiling should be prepared on a .dwg format and reflected on a scaled (Imperial Units) truss/lighting plot plan, submitted along with this order form. A Reflective Ceiling Plot (RCP) may be requested electronically from the installing city to assist you in completing your drawing. is able to provide assistance at creating the .dwg for your truss rig at an additional cost. Please see example attached.

Assembly

is required to assemble your flown truss prior to installation. See Step 1 of this form for rates.

Location of Truss

- Aerial/Flown Ground Supported

Use the Booth Layout Form provided in the kit to represent your booth and indicate truss location from booth boundaries the placement of your sign. Truss Orientation must be given by providing surrounding booth numbers.

Hoists

Are hoists required?

- Yes No

if yes, how many? _____

- Exhibitor Owned GES Rental

Exhibitor owned hoists must be certified. If asked upon on show floor for records, exhibitor must provide within 1 hour of request.

Please note that GES will automatically apply a motor outlet for every hoist placed in the booth on your account.

For installations that are deemed considerably heavy, our of the ordinary or unusual, a structural engineer stamp may be required at discretion. Work is done at exhibitor's risk and exhibitor shall indemnify and defend and the show organizer from any claims and/or bodily injuries arising out of or related to the installation of any truss with out engineered stamped drawings.

061600445

101116

H-2 072616



Hanging Sign / Truss Labor Order Form

All orders are governed by the GES Payment Policy and GES Terms & Conditions of Contract as specified in this Exhibitor Services Manual.

Discount Deadline Date:
October 21, 2016

Company Name _____ Email _____ Phone Number _____ Booth Number _____

Show Site Contact _____ Show Site Email _____ Show Site Phone Number _____

Step 3. Schedule Hanging Sign Labor for Exhibitor Supervised Work

Starting time can be guaranteed only when labor is requested for the start of the working day. All exhibit labor scheduled at the start of the working day will be dispatched to booth space. Confirm labor and equipment by 2:30 PM the day before date requested. If labor is not requested for the start of the working day, please have a representative pick up the crew at the labor desk and supervise the work to be done. Upon completion, the Exhibitor's representative will return the crew to the labor desk and approve the work order. Equipment and labor cancelled without a 24 hour notice shall be charged a one (1) hour cancellation fee per worker and equipment. If Exhibitor fails to use the workers and equipment at the time confirmed, a one (1) hour "Not Ready" charge per worker and equipment will apply.

The minimum charge for labor is one (1) hour per worker and equipment. Labor thereafter is charged in half (½) hour increments per worker and equipment. Gratuities in any form, including cash, gifts, or labor hours for work not actually performed are prohibited by GES. GES requires the highest standards of integrity from all employees. Please call our confidential Always Honest hotline at 866.225.8230 to report fraudulent or unethical behavior. All rates are subject to change if necessitated by increased labor and material costs.

Please estimate the number of workers and hours per worker needed for installation. Invoice will be calculated according to actual hours worked, relative to the original estimate and based upon the date received. Additional labor required will be calculated and invoiced at the show site rate.

Move In

Schedule Dates	Schedule Start Time	Schedule End Time	Number of Lifts/Workers
MM/DD/YR	AM PM	AM PM	
MM/DD/YR	AM PM	AM PM	

Schedule Dates	Schedule Start Time	Schedule End Time	Number of Lifts/Workers
MM/DD/YR	AM PM	AM PM	
MM/DD/YR	AM PM	AM PM	

Move Out

Schedule Dates	Schedule Start Time	Schedule End Time	Number of Lifts/Workers
MM/DD/YR	AM PM	AM PM	
MM/DD/YR	AM PM	AM PM	

Schedule Dates	Schedule Start Time	Schedule End Time	Number of Lifts/Workers
MM/DD/YR	AM PM	AM PM	
MM/DD/YR	AM PM	AM PM	

Total and Sign: Return to Fax: 866.329.1437 • International Fax: 702.263.1520

Please Sign

X

Authorized Signature

Authorized Name - Please Print

Date

I agree in placing this order that I have accepted Payment Policy and Terms & Conditions of Contract, including authorization for to retain personal information to better serve my need for services at future events.

Total Payment Enclosed

\$

101116 061600445

H-2 072616



Booth Layout - Hanging Signs

All orders are governed by the GES Payment Policy and GES Terms & Conditions of Contract as specified in this Exhibitor Services Manual.

Seattle International Auto Show
CenturyLink Field Event Center
November 10 - 13, 2016

Form Deadline Date:
October 21, 2016

Company Name _____ Email _____ Phone Number _____ Booth Number _____

Show Site Contact _____ Show Site Email _____ Show Site Phone Number _____



Form Tips:

- Use bold lines to indicate the outline of your exhibit space.
- If this grid scale is too small for easy drawing return a separate sheet indicating booth layout.
- Return multiple booth layouts if necessary.

Step 1. Booth Information

Each square is _____ feet square since my booth is _____ feet wide by _____ feet long.

Back Adjacent Booth or Aisle Number: _____

Right Side Adjacent Booth or Aisle Number: _____

Left Side Adjacent Booth or Aisle Number: _____

Front Adjacent Booth or Aisle Number: _____

Step 2. Draw Your Booth Layout

Front of Booth

101116 061600445

H-3 102615

Review and Return: Return to Fax: 866.329.1437 • International Fax: 702.263.1520



Use these shipping labels as they will expedite handling. Copies of these labels are acceptable if additional labels are needed.



FROM:



FROM:

Please print this label on a color printer if possible



TO:

Full Exhibiting Company Name at Show

Seattle International Auto Show

Name of Exhibition 0610600445

Booth Number

C/O GES
4060 Lind Avenue SW
Renton, WA 98057 USA

Shipment Should Arrive on or Between:
Monday, Oct 10, 2016 - Tuesday, Nov 1, 2016

Certified Weight Tickets are required for all Shipments. Drivers must check in by 2:00 PM to be guaranteed same day unloading. Warehouse receiving hours are Monday - Friday, 7:30 AM - 3:30 PM; Closed 12:00 PM - 1:00 PM & Holidays.

Carrier Number of pieces GES Global Experience Specialists



TO:

Full Exhibiting Company Name at Show

Seattle International Auto Show

Name of Exhibition 0610600445

Booth Number

C/O GES
4060 Lind Avenue SW
Renton, WA 98057 USA

Shipment Should Arrive on or Between:
Monday, Oct 10, 2016 - Tuesday, Nov 1, 2016

Certified Weight Tickets are required for all Shipments. Drivers must check in by 2:00 PM to be guaranteed same day unloading. Warehouse receiving hours are Monday - Friday, 7:30 AM - 3:30 PM; Closed 12:00 PM - 1:00 PM & Holidays.

Carrier Number of pieces GES Global Experience Specialists

Please print this label on a color printer if possible

Cleaning and Porter Service Order Form

All orders are governed by the GES Payment Policy and GES Terms & Conditions of Contract as specified in this Exhibitor Services Manual.

Seattle International Auto Show
 CenturyLink Field Event Center
 November 10 - 13, 2016

Discount Deadline Date:
 October 21, 2016

Company Name _____ Email _____ Phone Number _____ Booth Number _____



Easy Ordering Tips:

- Vacuuming includes emptying your wastebasket nightly.
- If ordering Porter Service, GES will empty wastebaskets and wipe down counters at two hour intervals during show hours only. (Vacuuming is not included. Calculate by your booth size.)
- Cost of services will be invoiced based on the total area of your booth.

Step 1. Calculate Booth Square Footage

Width 10 X Length 10 = 100 Total Sq. Ft.

Step 2. Order Cleaning Services

Vacuuming

Item Code	Description	Discount (\$)	Regular (\$)	Sq. Ft.	# of Days / Qty	Total
500601	Before Show Open Only (per sq. ft.)	0.23	0.28		1	\$
500600	Duration of Show (per sq. ft. per day)	0.08	0.12		4	\$
500602	Per Day (per sq. ft. per day)	0.10	0.14			\$

Porter Service - Emptying Wastebaskets

Item Code	Description	Discount (\$)	Regular (\$)	Sq. Ft.	Total
501010	Porter Service, 0-500 sq.ft., Per Day	115.50	173.25		\$
501010	Porter Service, 501-1500 sq.ft., Per Day	143.00	214.50		\$
501010	Porter Service, 1501-3000 sq.ft., Per Day	173.75	261.00		\$

Step 3. List dates and times Vacuuming Per Day/Periodic Porter Service is needed:

Schedule Dates	Schedule Start Time	Schedule End Time	Schedule Dates	Schedule Start Time	Schedule End Time	Schedule Dates	Schedule Start Time	Schedule End Time
MM/DD/YR	AM PM	AM PM	MM/DD/YR	AM PM	AM PM	MM/DD/YR	AM PM	AM PM
MM/DD/YR	AM PM	AM PM	MM/DD/YR	AM PM	AM PM	MM/DD/YR	AM PM	AM PM

Total and Sign: Return to Fax: 866.329.1437 • International Fax: 702.263.1520

Please Sign

X

 Authorized Signature

 Authorized Name - Please Print Date

I agree in placing this order that I have accepted GES Payment Policy and GES Terms & Conditions of Contract, including authorization for GES to retain personal information to better serve my need for GES services at future events.

Total Payment Enclosed \$ _____

Cancellation Policy: Due to material and labor costs, orders cancelled before move-in begins will be charged **50%** of original price. Similarly, orders cancelled after move-in will be charged **100%**.

101116 061600445
 J-1 100316



Notice of Intent to Use EAC and Policies and Procedures

All orders are governed by the GES Payment Policy and GES Terms & Conditions of Contract as specified in this Exhibitor Services Manual.

Seattle International Auto Show
CenturyLink Field Event Center
November 10 - 13, 2016

Form Deadline Date:
October 9, 2016

Company Name _____ Email _____ Phone Number _____ Booth Number _____



Attention:

- This form is to be completed by the Exhibitor

An Exhibitor Appointed Contractor (EAC) is a company other than the "general or official" service provider on the show that requires access to your booth during installation and dismantling. The EAC may only provide services in the facility that are not designated by the facility as "exclusive" to a designated provider, or by the show organizer in a contract as an exclusive service for the "general or official" service provider or other third party.

No EAC will be allowed to work in an exhibitor's booth if this Notice of Intent to Use EAC and Policies and Procedures form, a valid Certificate of Insurance and the Agreement, and Rules and Regulations between GES and the EAC form is not completed by an authorized representative and received by GES by the deadline indicated above. This Notice of Intent to Use EAC and Policies and Procedures form must be completed for every third party (as well as any other third party ordering or requesting services from GES on behalf of exhibitor) at the above show. Multiple booths are not to be listed on one form.

Exhibitor Appointed Contractor: _____

Contact Name: _____ Cell Phone: _____

Street Address: _____ Email: _____

City: _____ State: _____ Zip/Postal Code: _____

Office Phone: (area code) _____ Fax: (area code) _____

Description of proposed service for Exhibitor: _____

This form will only be accepted if it is executed by an authorized representative of the exhibiting company, and must include:

- An executed Agreement and Rules and Regulations between GES and EAC.
- A valid certificate of insurance prepared by the EAC's insurance agent with the minimum coverages as set forth in the Agreement and Rules and Regulations between GES and EAC.



X

Authorized Cardholder's Signature

Authorized Cardholder's Name - Please Print Date

Review and Return [Return to Fax: 866.329.1437](tel:866.329.1437) • [International Fax: 702.263.1520](tel:702.263.1520)

GES shall have no liability to any party for damage or injuries caused by exhibitor or its third party agents. It is the exhibitor's responsibility to provide its EACs with all show rules and regulations as set forth in the exhibitor space lease and the Exhibitor Services Manual. Exhibitor agrees to indemnify and defend GES for the actions of its agents and exhibitor appointed contractors. The exhibitor agrees that it is ultimately responsible for all services in connection with the exhibit, including freight, rentals and labor. Exhibitor agrees to be responsible for any losses, damages or injuries that are caused by or attributed to EACs that are not covered or provided by EAC's insurance.

101116 061600445

L-3/L-4 040116



Agreement and Rules and Regulations between GES and EAC

All orders are governed by the GES Payment Policy and GES Terms & Conditions of Contract as specified in this Exhibitor Services Manual.

Seattle International Auto Show
CenturyLink Field Event Center
November 10 - 13, 2016

Form Deadline Date:
October 9, 2016

Company Name	Email	Phone Number	Booth Number
--------------	-------	--------------	--------------



Attention:

- This form is to be completed by the EAC

The undersigned Exhibitor Appointed Contractor (EAC) has been designated by an exhibitor to perform certain services for the exhibitor at the above referenced show. In consideration of the show organizer and GES permitting the EAC to perform such services at the show, the EAC and GES hereby agree as follows:

Rules and Regulations

- EAC agrees to comply with all rules and regulations of the show as outlined in this agreement, the Exhibitor Services Manual, including all union rules and regulations, and accept liability for any negligent actions.
- EAC agrees that it must ascertain and comply with all rules and regulations of the venue, Show Management, and/or the Official Service Provider in order to create a safe work environment. A failure to do so can result in a delay or termination of your right to continue work if the condition cannot be corrected.
- EAC agrees that the show site, dock and surrounding areas are active work zones and the EAC, its agents, employees and representatives are present at their own risk. Entry into the dock area is prohibited.
- EAC must have all business licenses and permits required by the State and City governments and the convention facility management prior to commencing work. A certificate of insurance naming GES as an additional insured with appropriate insurance limits prepared by the EAC's insurance agent must be submitted to GES at least 30 days prior to the first date of move-in.
- This Agreement and Rules and Regulations between GES and EAC must be completed by an authorized representative of EAC and returned to GES before the deadline noted above.
- If the EAC fails to provide the documentation required in paragraphs 4 and 5 above, the exhibitor will be required to use GES for such services at the prevailing rates set forth in the Exhibitor Services Manual.
- EAC shall provide, if requested, evidence to Global Experience Specialists, Inc. (GES) that it possesses applicable and current labor contracts and must comply with all labor agreements and practices. The EAC must not commit or allow to be committed by persons in its employment any acts that could lead to work stoppages, strikes or labor problems.
- EAC will be responsible for all reasonable costs related to its operation, including overtime pay for stewards, restoration of exhibit space to its initial condition, etc. Where applicable a one hour minimum labor charge will be charged at the appropriate steward rate of pay per day/per union to either the EAC/exhibitor depending upon the billing arrangement set up with GES (based upon EAC not number of booths).
- The show aisles and public spaces are not part of the exhibitor's booth. Therefore, EAC is required to confine all activities to the exhibit space of the exhibitor who has given a valid order for services. Exhibitors may be charged for costs related to movement of its property if the EAC does not contain its operations within the confines of the booth. No service desks, storage areas or other work facilities will be located anywhere in the building. The show aisles and public space are not a part of the exhibitor's booth space and must be kept clear at all times.
- During show hours, only EACs with exhibit badges will be permitted on the exhibit floor. No EAC will be permitted on the exhibit floor during show hours without the proper Convention name badge supplied by the exhibiting company. EAC must furnish Show Management and GES with the names of all on-site employees who will be working on the show floor and ensure that they have and wear identification badges at all times necessary as determined by Show Management.
- EAC has attached herewith certificates of insurance confirming the following required insurance:
 - Commercial General Liability, including contractual liability, with limits of not less than \$1,000,000 each occurrence, \$2,000,000 general aggregate and \$2,000,000 products & completed operations aggregate.
 - Automobile Liability with a limit of not less than \$1,000,000 combined single limit - each accident.
 - Workers Compensation, as required by law, with Employers Liability Limits of not less than \$1,000,000 each accident, \$1,000,000 disease - each employee and \$1,000,000 disease - policy limit.
 - Umbrella/Excess Liability with a limit of not less than \$1,000,000 each occurrence/aggregate.
 - The Commercial General and Automobile Liability Policies shall name Global Experience Specialists, Inc. (GES) (Official Service Provider), Washington State Auto Dealers Association (Show Management), Seattle International Auto Show (Show) and CenturyLink Field Event Center (Facility) as additional insureds on a primary and non-contributory basis per the attached sample certificate of insurance.
- EAC agrees to indemnify, defend and hold the Show Management, the Facility and Global Experience Specialists, Inc. (GES) harmless from and against any and all claims, lawsuits, demands, liability, costs and expenses, including reasonable attorney's fees and court costs, arising out of EAC's operations, including supervision of GES provided labor. EAC also agrees to reimburse GES for all attorney's fees and costs incurred in connection with any and all claims, lawsuits and counterclaims that should arise out of EAC's failure to adhere to the terms of this agreement.
- Solicitation of business on the show floor is strictly prohibited. If EAC attempts to provide services designated to another party as "exclusive" or is discovered soliciting on the show floor including the distribution of official company literature, or otherwise does not comply with the rules, the company may be removed from the show floor, and the exhibitor will not be able to use that company for the remainder of the event.
- EAC/ exhibitor may not move freight from one booth to another booth, or to meeting rooms. GES must provide labor.
- EAC must coordinate all of its activities with Global Experience Specialists, Inc. (GES).
- The exhibitor or its EAC should order services required from GES and the Exhibit Hall in advance. Ordering labor or services onsite (which contractors may not be prepared to provide immediately) may delay the set-up of your booth or force your set-up into overtime.

L-3/L-4 040116 101116 061600445



Agreement and Rules and Regulations between GES and EAC

All orders are governed by the GES Payment Policy and GES Terms & Conditions of Contract as specified in this Exhibitor Services Manual.

Seattle International Auto Show
 CenturyLink Field Event Center
 November 10 - 13, 2016

Form Deadline Date:
 October 9, 2016

Company Name	Email	Phone Number	Booth Number
--------------	-------	--------------	--------------

Rules and Regulations (continued)

17. The exhibitor or its EAC should take steps to protect the exhibitor and the EAC's product in the booth by arranging for booth security and/or cages. GES is not responsible for items left unattended on the show floor.
18. EAC agrees GES is not responsible for any items stored in empty containers. Do not store empty cartons inside of empty crates. Cartons are returned from storage before crates so exhibitors may begin packing their product.
19. EAC/exhibitor agrees to keep "No Freight Aisles" clear at all times. If GES is required to rearrange any material situated in a clearly identified "No Freight Aisle," the exhibitor or the EAC depending upon the billing arrangements with GES will be charged a one hour minimum for forklift rental and labor.
20. EAC/exhibitor agrees that all outbound freight bills should be turned into the service desk on a timely basis. Holding freight bills until late in the day or turning in large amounts of freight bills to the GES Servicerenter at one time may delay outbound truck scheduling and subsequently force your loading out into overtime.
21. During tear down, pull all manageable structures back from aisle carpet lines. Electronics, mannequins, etc. should be placed in the center of the booth.
22. Be aware of vehicle traffic inside and outside of the facility. All attendees should be aware of their surroundings and all individuals are solely responsible for their own safety in parking lots, driveways, access roads and non-exhibit hall areas.
23. Label empty cartons and crates for storage as soon as they are ready. Holding back on "empties" only adds congestion to the aisles.
24. For services such as electrical, plumbing, telephone, cleaning and drayage, no service provider other than the Official Service Provider will be approved. This regulation is necessary due to licensing, insurance and work done on equipment and facilities owned by parties other than the exhibitor. Exhibitors shall provide only the material and equipment they own and those materials are to be used only in their exhibit space.
25. Smoking is prohibited in most facilities. Smoking shall only be allowed in designated areas.
26. This agreement is to be interpreted under the laws of the State of Nevada.
27. A faxed signature will serve as an original signature and will stand as a fully executed agreement once faxed to and received by GES.

Authorized Signature of EAC:

Please Sign _____
 Authorized Cardholder's Signature

 Authorized Cardholder's Name - Please Print

 Date

Review and Return Return with Certificate of Insurance to: Global Experience Specialists, Inc. (GES), Exhibitor Services, 4060 Lind Avenue SW, Renton, WA 98057

Printed Name: _____
 Title: _____
 Company: _____
 Address: _____ City: _____ State: _____ Zip/Postal Code: _____
 Contact Name at Show Site: _____
 Office Phone: _____ Cell Phone at Show Site: _____

Official Use Only	
Accepted by GES Authorized Representative:	
X	
Authorized Signature	
Authorized Name - Please Print	Date

L-3/L-4 040116 101116 061600445



ACORD 1. CERTIFICATE OF LIABILITY INSURANCE DATE (MM/DD/YY)
01/01/16

PRODUCER ABC Insurance Agency Fax: (212) 555-6100 1234 Broker Lane New York, NY 10895 Attn: Joe Agent (212) 555-6102 ext. 1234	THIS CERTIFICATE IS ISSUED AS A MATTER OF INFORMATION ONLY AND CONFERS NO RIGHTS UPON THE CERTIFICATE HOLDER, THIS CERTIFICATE DOES NOT AMEND, EXTEND OR ALTER THE COVERAGE AFFORDED BY THE POLICIES BELOW. INSUREERS AFFORDING COVERAGE
---	---

INSURED 2. Big Boom Company, Inc. 1234 Corporate Lane New York, NY 10895 Attn: Joe Smith Phone: (212) 555-5349 Fax: (212) 555-9819	INSURER A: Hartford Insurance Company of Illinois INSURER B: Aetna Casualty & Surety Company INSURER C: Travelers Insurance Company INSURER D: Royal Insurance Company INSURER E:
--	---

3. COVERAGES
 THE POLICIES OF INSURANCE LISTED BELOW HAVE BEEN ISSUED TO THE INSURED NAMED ABOVE FOR THE POLICY PERIOD INDICATED, NOTWITHSTANDING ANY REQUIREMENT, TERM OF CONDITION OF ANY CONTRACT OR OTHER DOCUMENT WITH RESPECT TO WHICH THIS CERTIFICATE MAY BE ISSUED OR MAY PERTAIN, THE INSURANCE AFFORDED BY THE POLICIES DESCRIBED HEREIN IS SUBJECT TO ALL THE TERMS, EXCLUSIONS AND CONDITIONS OF SUCH POLICIES. LIMITS SHOWN MAY HAVE BEEN REDUCED BY PAID CLAIMS.

INSR LTR	4. TYPE OF INSURANCE	POLICY NUMBER	7. POLICY EFFECTIVE DATE (MM/DD/YY)	8. POLICY EXPIRATION DATE (MM/DD/YY)	9. LIMITS
A	GENERAL LIABILITY <input checked="" type="checkbox"/> COMMERCIAL GENERAL LIABILITY <input type="checkbox"/> CLAIMS MADE <input checked="" type="checkbox"/> OCCUR <input type="checkbox"/> _____ <input type="checkbox"/> _____ GENERAL AGGREGATE LIMIT APPLIES PER <input type="checkbox"/> POLICY <input type="checkbox"/> PROJECT <input type="checkbox"/> LOC	000P98298-A11	01/01/16	01/01/17	EACH OCCURRENCE \$1,000,000
	FIRE DAMAGE (Any one fire) \$ 50,000				
	MED EXP (Any one person) \$ 5,000				
	PERSONAL & ADV INJURY \$1,000,000				
	GENERAL AGGRREGATE \$2,000,000				
	PRODUCTS-COMP/OP AGG \$2,000,000				
B	AUTOMOBILE LIABILITY <input checked="" type="checkbox"/> ANY AUTO <input type="checkbox"/> ALL OWNED AUTOS <input type="checkbox"/> SCHEDULED AUTOS <input type="checkbox"/> HIRED AUTOS <input checked="" type="checkbox"/> NON-OWNED AUTOS <input type="checkbox"/> _____ <input type="checkbox"/> _____	SKLS-029499S	01/01/16	01/01/17	COMBINED SINGLE LIMIT \$1,000,000 (Ea accident)
	BODILY INJURY \$				
	(Per person)				
	BODILY INJURY \$				
	(Per accident)				
	PROPERTY DAMAGE \$ (Per accident)				
A	GARAGE LIABILITY <input type="checkbox"/> ANY AUTO <input type="checkbox"/> _____	XL1234567	01/01/16	01/01/17	AUTO ONLY-EA ACCIDENT
	OTHER THAN AUTO ONLY: \$ \$				
	EACH OCCURRENCE \$1,000,000				
	AGGREGATE \$1,000,000				
C	UMBRELLA/EXCESS LIABILITY <input checked="" type="checkbox"/> OCCUR <input type="checkbox"/> CLAIMS MADE <input type="checkbox"/> DEDUCTIBLE <input type="checkbox"/> RETENTION \$	A4145-SS-PJ37	01/01/16	01/01/17	X WC STATU-ORY LIMITS OTHER
	E.L. EACH ACCIDENT \$1,000,000				
	E.L. DISEASE-EA EMPLOYEE \$1,000,000				
	E.L. DISEASE -POLICY LIMIT \$1,000,000				
D	OTHER				Each Occurrence & Aggregate

5. DESCRIPTION OF OPERATIONS/LOCATIONS/VEHICLES/EXCLUSIONS ADDED BY ENDORSEMENT/SPECIAL PROVISIONS
 Global Experience Specialists, Inc. (GES) (Official Service Provider), Washington State Auto Dealers Association (Show Management), CenturyLink Field Event Center (Facility), and Seattle International Auto Show (Show) are hereby named as additional insured, except for Workers' Compensation. Global Experience Specialists, Inc. (GES) and/or the consignor are included as Loss Payee. The insurance provided for the benefit of Global Experience Specialists, Inc. (GES), shall be primary insurance as respects any claim, loss, or liability, arising out of the Named Insured's operations for which the Named Insured is liable. Any other insurance maintained by GES shall be excess and non-contributory. Show date(s) are: November 10 - 13, 2016 at city of Seattle.

CERTIFICATE HOLDER X	ADDITIONAL INSURED; INSURER LETTER: X	CANCELLATION
Global Experience Specialists, Inc. (GES) Exhibitor Services 4060 Lind Avenue SW Renton, WA 98057		SHOULD ANY OF THE ABOVE DESCRIBED POLICIES BE CANCELLED BEFORE THE EXPIRATION DATE THEREOF, THE ISSUING COMPANY WILL ENDEAVOR TO MAIL 30 DAYS WRITTEN NOTICE TO THE CERTIFICATE HOLDER NAMED TO THE LEFT, BUT FAILURE TO DO SO SHALL IMPOSE NO OBLIGATION OR LIABILITY OF ANY KIND UPON THE INSURER, ITS AGENTS OF REPRESENTATIONS AUTHORIZED REPRESENTATIVE <div style="text-align: right; margin-top: 10px;"> 10. </div>

1. **Producer:** Insurance Agent / Broker who issues certificate.
2. **Name of Insured:** Must be the legal name of contracting party.
3. **Types of Insurance:** Must include types required by contract. See General Information form in this Exhibitor Services Manual.
4. **Form of Coverage:** Must be "occurrence" form of coverage.
5. **Name of Additional Insureds:** Global Experience Specialists, Inc. (GES) (Official Service Provider), Washington State Auto Dealers Association (Show Management), Seattle International Auto Show (Show) and CenturyLink Field Event Center (Facility) as additional insureds on a primary and non-contributory basis.
6. **Certificate Holder:** Must be Global Experience Specialists, Inc. (GES)
7. **Policy Effective Date:** Must be prior to or coincidental with the first day of Exhibitor Move-In.
8. **Policy Expiration Date:** Must be on or after the last day of Exhibitor Move-Out.
9. **Limits of Insurance:** Must be the same or greater than required by contract. See #11 on Agreement and Rules and Regulations between GES and EAC.
10. **Authorized Representative:** Must be signed (not stamped) by an authorized representative of Producer.

L-3/L-4 040116 101116 061600445



Show Site Work Rules

All orders are governed by the GES Payment Policy and GES Terms & Conditions of Contract as specified in this Exhibitor Services Manual.

Seattle International Auto Show
CenturyLink Field Event Center
November 10 - 13, 2016

Union Information

To assist you in planning your participation in your show, we are certain you will appreciate knowing in advance that union labor will be required for certain aspects of your exhibit handling.

Exhibit Labor

GES offers experienced union labor exclusively through the Pacific Northwest Regional Council of Carpenters to assist with the installation of your exhibit booth(s). A full-time employee of the exhibiting company may set their own exhibit provided that one person can accomplish the task in less than one-half hour (30 minutes) and without the use of tools or ladders. Also it is permissible for one (1) full time, company employee to supervise GES Carpenters on the work, or GES will provide a foreman for that function at applicable rates.

Freight Handling Jurisdiction

GES has the responsibility of receiving and handling all exhibit materials and empty crates. It is our responsibility to manage docks and schedule vehicles for the smooth, safe, and efficient move-in and move-out of the exposition. Exhibitors may hand-carry their own materials into the exhibit hall through the hand carry entrance. The use of mechanical equipment by exhibitors is not permitted. Access to the loading docks will be controlled by GES in order to provide for a safe and efficient move-in and move-out. GES will not be responsible, however, for any materials we do not handle.

Gratuities

Our work rules prohibit the solicitation or acceptance of tips in cash, product or gifts in kind by any employee (union or non-union). Our employees are paid appropriate wages denoting professional status, therefore tipping of any kind is not allowed. GES requests that exhibitors do not tip (such practices as giving money, merchandise, or other special consideration for service rendered) to our employees. Do not give coffee breaks other than mid-morning and mid-afternoon, when employees have a fifteen minute paid break. Any attempts to solicit a gratuity by an employee for any service should be reported immediately to a GES supervisor. Employees of GES are paid at an excellent wage scale and thus, tipping is strongly discouraged as not being an accepted policy of GES. This applies to all GES employees.

Work Zone

Customer acknowledges that the show site and surrounding areas are active work zones. Customer, its agents, employees and representatives are present at their own risk.

Always Honest Hotline

GES requires the highest standards of integrity from all employees. Please call our confidential Always Honest Hotline at (866) 225-8230 to report fraudulent or unethical behavior.

101116 061600445

G-6 060816

Stop. Think. Safety.

All orders are governed by the GES Payment Policy and GES Terms & Conditions of Contract as specified in this Exhibitor Services Manual.

Seattle International Auto Show
CenturyLink Field Event Center
November 10 - 13, 2016



Safety is very important for everyone working in the Exhibit Hall.

GES values safety throughout our organization and demonstrates it in the work we perform. By following the safety guidelines below you will be doing your part in creating a safe work environment.

Safety Guidelines:

- Only authorized personnel and employees allowed, all others are prohibited.
- This is an active work zone.
- All exhibitors and attendees enter at their own risk. Do not enter the dock/yard areas.
- Only authorized personnel and employees allowed, all others are prohibited.
- This is an active work zone.
- Stay clear of heavy machinery.
- Never stand on furniture.
- Wear closed toe shoes.
- Clean up or report spills.
- Keep aisles free and clear of any and all debris.
- Practice good housekeeping.
- Check electrical cords for damage.
- Protect valuables at show site.
- Report any fires immediately.

If you notice anything unsafe please contact a GES employee immediately.

During move in and move out individuals under the age of 18 are prohibited from being on or around the show floor. Show sites during these times are similar to a construction zone and considered to be hazardous. OSHA regulations prohibit minors from being present in a hazardous work environment.

Fire Regulations

All orders are governed by the GES Payment Policy and GES Terms & Conditions of Contract as specified in this Exhibitor Services Manual.

Seattle International Auto Show
CenturyLink Field Event Center
November 10 - 13, 2016

SEATTLE FIRE DEPARTMENT RULES & REGULATIONS FOR EXHIBITS

1. All decorations, drapes, signs, banners, plastic displays, hay, split bamboo, combustibles, etc. **must be flame-retardant and accompanied by a Flame Certificate that verifies that they are flame-retardant.** Wood panels greater than 1/4" original thickness are considered flame-resistant. The use of oilcloth, tarpaper, sisal paper, nylon, Orlon, and certain synthetic materials cannot be made flame resistant, and **their use is strictly prohibited.**
2. Special Effects permits are required for indoor fireworks, etc. Each of these effects will be subject to extensive review and will be handled on a case-by-case basis. Permits are not required to use smoke machines or lasers. Smoke machine usage must be communicated to the Fire Marshal and Convention Facilities Event Manager in case it becomes necessary to authorize deactivation of smoke sensors.
3. Displayed vehicles must be indicated on submitted floor plans and are subject to the following restrictions:
 - a. Fuel in tanks is limited to a maximum of ¼ tank or five (5) gallons, whichever is less. Diesel fuel tanks are limited to a maximum of ¼ tank. **Vehicles with no or non-functioning fuel gauges will not be allowed in public assembly areas without prior approval by the Fire Marshal.**
 - b. Battery cables must be disconnected, with the cable ends taped over to prevent sparking.
 - c. Fuel tank fill caps must either be lockable or taped shut.
4. Deep fat fryers can be used under the following conditions without prior approval or permit:
 - a. Maximum capacity 1 gallon.
 - b. Fire extinguisher readily available in the booth with a minimum UL rating of [Class "K".] This fire extinguisher is in **ADDITION** to any built in suppression system.
 - c. A metal cover capable of covering the deep fat fryer shall be readily available in the booth.

NOTE: Deep fat fryers with a capacity of more than 1 gallon require advance approval from the Fire Marshal.

5. Candles may only be used in public assembly areas if under permit for Open Flame, and only within an approved container (specific conditions apply). Sterno does not require a permit.
6. LPG (Propane) and CNG (Compressed Natural Gas) are prohibited in the Convention Center. Exception: 8-oz. butane canisters, which are used in conjunction with tabletop burners. Each exhibit booth is limited to one 8-oz. canister. If additional canisters are needed, they must be stored outside the building in an area that is acceptable to the Fire Department and the Convention Facility. (Specific approval is required for any cooking within a booth)
7. Combustible storage is not allowed on the event floor. Combustible storage is specifically prohibited in dead areas, behind booth drapes or in unsold areas. Empty cardboard boxes intended for repackaging must be removed from the event floor. Booth storage of literature/brochures is limited to full boxes that can be easily stored under tables in the booth.
8. Helium, Nitrogen, Oxygen and Nitrous oxide tanks are allowed on the event floor with prior approval by the Fire Marshal. Tanks must be properly labeled for contents and firmly secured in the upright position, with valves protected against damage. Nitrous oxide and Oxygen tanks over 250 cubic feet are prohibited. Oxidizing gases (Oxygen or Nitrous oxide) in amounts in excess of 503 cubic feet may only be used in public assembly areas under permit for Hazardous Materials.

Exhibit Hall Guidelines:

1. All fire hose cabinets and fire extinguishers must be visible and kept clear and readily accessible during move-in, show days and move-out. The issue of visibility and ease of access to fire equipment applies to the event floor as well as service corridors.
2. Large covered booths [over 100 square feet] require that the floor plan and booth plan be pre-approved by the Fire Marshal. Booths up to 300 square feet require a 2A 10BC fire extinguisher and a smoke detector.

NOTE: In covered booths over 300 square feet, the Fire Marshal will require that a fire suppression system be installed in the booth.

Multi-Level and Covered Exhibit Booths:

This information is provided as a general guideline of the policies pertaining to the installation of a multi-level or covered booth. These regulations are described in the National Fire Protection Act (Section 12.7.4.3.7), as applied by the Seattle Fire Department, as well as in the Seattle Building Code and Convention Facility Policy. Facility Clients, Exhibit Managers, Show Decorators, and/or General Service Contractors are responsible for ensuring that all exhibitors are aware of and comply with these regulations. The review process for covered or multi-level booths should be started early to ensure approval before the start of the show. Please contact your GES, Global Experience Specialist, if you have questions regarding this information or the overall process

G-8 092916 101116 061600445

Fire Regulations

All orders are governed by the GES Payment Policy and GES Terms & Conditions of Contract as specified in this Exhibitor Services Manual.

Seattle International Auto Show
CenturyLink Field Event Center
November 10 - 13, 2016

Definitions

Covered Booth: A booth that has any material or object placed over or upon the exhibit is considered a covered booth. (e.g. roof, canopy, tent, Moss fabric, etc.)

Multi-level Booth: An exhibit that has a second level or tier constructed on top of the exhibit or portion of the exhibit, is accessed by stairs, and can be occupied by persons is considered a multi-level booth.

Covered Booths of 100 to 299 square feet

Booth plan must be reviewed and approved by the Fire Marshal at least 3 months in advance. A detailed .pdf drawing of the proposed exhibit, to include exact dimensions of covered area Minimum of (1) "2A 10BC" rated fire extinguisher must be placed within the covered area. A smoke detector must be placed at the highest point of each covered area. There must be a means of turning off electrical power to the booth during non-show hours.

Covered & Multi-level booths of 300 square feet and above

In addition to the above requirements, the following will apply: A minimum of 3 months lead-time may be required for the approval process. An approved temporary automatic fire suppression sprinkler system must be installed.

The following information needs to be provided to the Fire Department Engineer:

- a. Name and contact information for the licensed & qualified sprinkler contractor.
- b. Engineer certified plans of the sprinkler head locations, pipe sizes, and flow calculations.

The exhibitor is allowed to select the qualified provider of their choice to design and install their in-booth sprinkler system.

Convention Center's selected life safety system contractor must connect the booth system to the facility's life safety system. Please contact the Facility Representative for an estimate of charges.

ALL Multi-level booths of any square footage

A Temporary Structure Permit must be obtained from Seattle Department of Planning and Development (DPD). Contact Joel Lehn at (206) 684-8600 or joel.lehn@seattle.gov.

The following information needs to be submitted to DPD at least 3 months in advance:

- a. Completed DPD application form and associated fees
- b. (2) Sets of stamped engineering drawings for DPD
- c. Letter of Structural Integrity
- d. DPD may require an onsite field inspection of the completed structure.
- c. (1) Set of drawings in .pdf format e-mailed to the CONVENTION FACILITY Events Representative

Special Considerations

Approval of a covered or multi-level booth plan is contingent upon final approval of the overall exhibit hall floor plan submitted by show management.

Coverings constructed of open grate or mesh greater than ¼ inch or a UL listed drop out ceiling may be exempt from the sprinkler requirement.

It is suggested that covered booths of less than 100 square feet submit plans to the GES, Global Experience Specialist, for review.

A series or combination of covered areas, whether in one booth or adjacent booths, must be separated by a minimum of 10 feet.

An exhibit that fails to comply with these regulations will not be allowed to install for the event.

Additional Fire Department Permits that May Be Required*:

Open Flame	Code #1102
Special Effects	Code #7801 and/or Code #7802
Flammable Liquid	Code #8020
Oxidizing Gases (Temporary Hazardous Materials)	Code #8208

*A complete listing of fees, appropriate applications and additional information may also be found on-line at: <http://www.cityofseattle.net/fire/FMO/fmo.htm>

Seattle Fire Department Fire Prevention Division

Phone: (206) 386-1331

Fax: (206) 386-1348

101116 061600445

G-8 092916

Operation of All Mechanical Lifts

All orders are governed by the GES Payment Policy and GES Terms & Conditions of Contract as specified in this Exhibitor Services Manual.

Seattle International Auto Show
CenturyLink Field Event Center
November 10 - 13, 2016

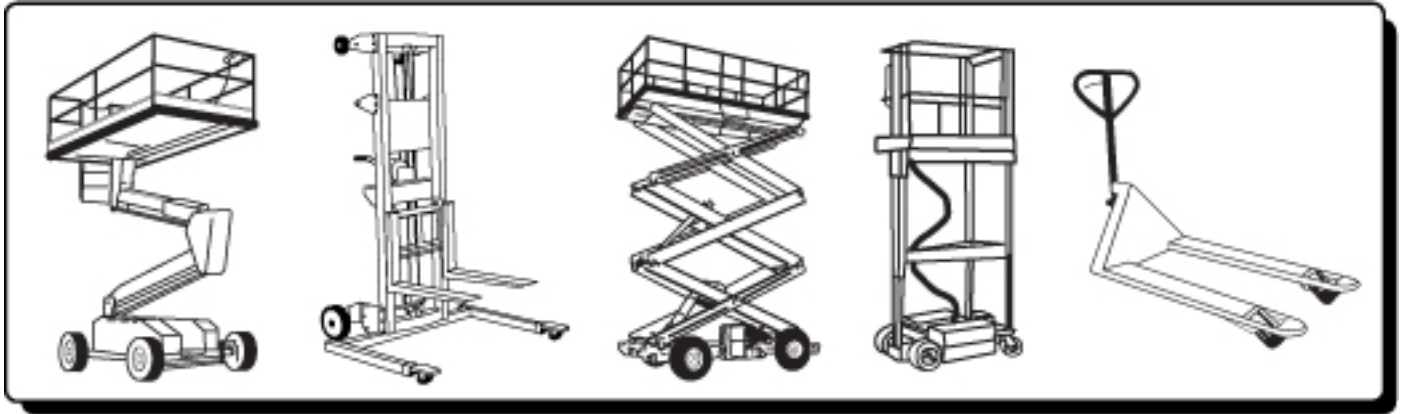

Attention all exhibitors:

- The operation or use of all motorized equipment for installation of booth structures or signs is not permitted by exhibitors or their appointed contractors.
- The operation or use of motorized or mechanical equipment, including mechanical scooters and carts, is not permitted by exhibitors or their appointed contractors for material handling. The use or prohibition of motorized scooters is controlled by and subject to the facility's rules, regulations and guidelines.
- All lifts, scooters, pallet jacks, dollies and manpower must be provided by the official service provider.
- Scooters and carts may only be used by the individuals to whom the scooters and carts are issued. GES equipment is for use by GES employees only. Please do not take it for your use.

Work Zone



- Customer acknowledges that the show site and surrounding areas are active work zones. Customer, its agents, employees and representatives are present on the show floor at their own risk.

Thank you for your complete cooperation.

101116 061600445

G-9 050916

GES Payment Policy

All orders are governed by the GES Payment Policy and GES Terms & Conditions of Contract as specified in this Exhibitor Services Manual.

Seattle International Auto Show
CenturyLink Field Event Center
November 10 - 13, 2016

Payment for Services

GES requires payment in full at the time services are ordered. Further, GES requires that you provide a credit card authorization with your initial order. For your convenience, we will use this authorization to charge your account for services, which may include labor, material handling, or any applicable fuel or energy surcharges.

Discount Prices

To qualify for discount pricing, orders must be received with payment on or before the discount price deadline(s).

Method of Payment

GES accepts MasterCard, Visa, American Express, check and bank ACH/Wire transfer.

Purchase orders are not considered payment. All payments must be made in U.S. funds drawn on a U.S. Bank. Exhibitors will be charged a \$50.00 fee for returned NSF checks.

Third Party Billing

Each exhibiting firm is ultimately responsible for all charges incurred on its behalf. GES reserves the right to institute collection action against the exhibitor if the authorized third party does not pay. See Third Party Billing Request form.

Tax Exempt

If you are tax exempt in the state in which you will be exhibiting, you must provide a Sales Tax Exemption Certificate for that state. Please send the above information to the GES office for this show.

Taxes vary by location and will be added to your invoice if you do not submit your tax exempt certificate prior to the deadline.

Adjustments and Cancellations

No adjustments to invoices will be made after the close of the show.

Please refer to the individual forms for labor and furnishings for cancellation fees. All orders cancelled by the Exhibitor or due to the cancellation of an event or their non-participation may be subject to cancellation fees equal to 50% - 100% of the total order, based upon the status of move-in, work performed and/or GES set-up costs or expenses.

A minimum non-refundable deposit of \$25.00 will be applied towards the invoice, unless there is a cancellation of your order. Additionally, GES retains the right to implement/assess a fuel or energy surcharge on all services as necessary based upon market conditions.

101116 061600445

G-2p 031016

GES Terms and Conditions of Contract

All orders are governed by the GES Payment Policy and GES Terms & Conditions of Contract as specified in this Exhibitor Services Manual.

Seattle International Auto Show
CenturyLink Field Event Center
November 10 - 13, 2016

GES Terms & Conditions are subject to change at GES' sole discretion without notice to any parties.

I. Definitions

GES: Global Experience Specialists, Inc., is hereinafter referred to as GES and/or GES Logistics, and/or Trade Show Electrical (a/k/a TSE) and/or Trade Show Rigging (a/k/a TSR) and their employees; Agents: GES' agents, sub-contractors, carriers, and the agents of each; Customer: Exhibitor or other party requesting Services from GES; Goods: Exhibits, property, and commodities of any type for which GES is requested to perform Services; Carrier: Motor carrier, van line, air carrier, or air or surface freight forwarder; Shipper: Party who tenders Goods to Carrier for transportation; Cold Storage: Holding of Goods in a climate controlled area; Accessible Storage: Holding of Goods in an area from which Goods may be removed during shows; Services: Warehousing, transportation, drayage, un-supervised labor, supervised labor and/or related services; Show Site: The venue or place where an exposition or event takes place; Supervised Labor (OK To Proceed): Union labor that is provided to a Customer to install or dismantle a booth or exhibit space, and is supervised and/or directed by GES; Un-Supervised Labor (Do Not Proceed): Union labor that is provided to a Customer to install or dismantle a booth or exhibit space and pursuant to Customer's election is not supervised and/or directed by GES. Customer assumes the responsibility and any liability arising therefrom, for the work of union labor when Customer elects to use un-supervised labor.

II. Scope

These Terms and Conditions shall be binding upon Customer, GES, and their respective Agents and representatives, including but not limited to Customer contracted labor such as Customer Appointed Contractors and Installation and Dismantle Companies, and any other party with an interest in the Goods. Each shall have the benefit of and be bound by all provisions stated herein, including but not limited to time limits and limitations of liability.

III. Customer Obligations

- a. Payment for services. Customer shall be liable for all unpaid charges for services performed by GES or Agents. Customer authorizes GES to charge its credit card directly for services rendered on Customer's behalf after departure, by placing an order on-line, via fax, phone or through a work order on site.
- b. Credit Terms. All charges are due before Services are performed unless other arrangements have been made in advance. GES has the right to require prepayment or guarantee of the charges at the time of request for Services. A failure to pay timely will result in Customer having to pay in cash in advance for future services. GES retains its right to hold Customer Goods for non-payment. If a credit card is provided to GES, GES is authorized to bill to such credit card any unpaid charges for services provided to Customer, including charges for return shipping. Any charges not paid within 30 days of delivery will be subject to interest at 1 ½% per month until paid.

IV. Mutual Obligation Indemnification

- a. Customer to GES: Customer shall defend, hold harmless and indemnify GES from and against any claims, lawsuits, demands, liability, costs and expenses, including reasonable attorney's fees and court costs, resulting from any injury to or death of persons, or damage to property other than Goods, relating to or arising from performance of Services herein. Customer agrees to indemnify and hold GES harmless for any and all acts of its representatives and agents, including but not limited to Customer Appointed Contractors and Installation and Dismantle Companies, any subtenant or other user of its space or any agents or employees engaged in business on behalf of Customer or present at Customer's invitation, including supervision of labor secured through GES. Customer's obligations under this provision shall not apply to GES' own negligence and/or willful misconduct. Customer acknowledges that the show site is an active work zone and customer, its agents, employees and representatives are present at their own risk.
- b. GES to Customer: To the extent of GES' own negligence and/or willful misconduct, and subject to the limitations of liability below, GES shall defend, hold harmless and indemnify Customer from and against any claims, lawsuits, demands, liability, costs and expenses, including reasonable attorney's fees and court costs, resulting from any injury to or death of persons, or damage to property other than Goods. GES' obligations under this provision shall not apply to claims for bodily injury arising a) from Customer's presence in areas which have been marked as "off limits to exhibitors"; and b) when exhibitors are present in the facility prior or subsequent to the effective dates or hours of Exhibitor's space lease with show management.

V. Disclaimer and Limitation of Liability

Under no circumstances will any party be liable for special, incidental, consequential indirect or punitive damages, including but not limited to loss of profits or income. GES shall be liable, subject to the limitations contained herein, for loss or damage to goods only if such loss or damage is caused by the direct negligence or willful misconduct of GES. Claims presented for loss or damage arising out of incidents referenced in section VI herein will be denied.

101116 061600445

G-7 062116



VI. No Liability for Loss or Damage to Goods

- a. Condition of Goods: GES shall not be liable for damage, loss, or delay to uncrated freight, freight improperly packed, glass breakage or concealed damage. GES shall not be liable for ordinary wear and tear in handling of Goods or for damage to shrink wrapped Goods. All Goods shall be able to withstand handling by heavy equipment, including but not limited to forklifts, cranes, or dollies. It is the Customer's responsibility to ensure that Goods are packaged correctly prior to shipment or movement on or off the Show floor.
- b. Receipt of Goods: GES shall not be liable for Goods received without receipts, freight bills, or specified piece count on receipts or freight bills, or for bulk shipments (i.e., UPS, air freight, or van lines). Such Goods shall be delivered to booth without the guarantee of piece count or condition.
- c. Force Majeure: GES shall not be liable for loss or damage that results from Acts of God, weather conditions, act or default of Customer, shipper, or the owner of the Goods, inherent nature of the Goods, public enemy, public authority, labor disputes, and acts of terrorism or war.
- d. Cold Storage: Goods requiring cold storage are stored at Customer's own risk. GES assumes no liability or responsibility for Cold Storage.
- e. Accessible Storage: GES assumes no liability for loss or damage to Goods while in Accessible Storage. Storage charges are for the use of space and are not a form of insurance, or a guarantee of security.
- f. Unattended Goods: GES assumes no liability for loss or damage to unattended Goods received at Show Site at any time from the point of receipt of inbound Goods until the loading of the outbound Goods, including the entire term of the respective show or exhibition. Customer is responsible for insuring its own Goods for any and all risk of loss.
- g. Empty Storage: GES assumes no liability for loss or damage to Goods or crates, or the contents therein, while containers are in Empty Storage. It is Customer's sole responsibility to affix the appropriate labels available at the GES Service Desk for empty container storage, and ensures that any pre-existing empty labels are removed.
- h. Forced Freight: GES is not liable for Customer Goods left on the show floor after the show closing deadline, with or without a Material Handling Services/Straight Bill of Lading signed by Customer. It is Customer's responsibility to complete accurate paperwork for shipping and to ensure Customer Goods are properly labeled. If Customer Goods remain on the floor after the show closing deadline, GES has the right to remove the Customer Goods. GES is authorized by Customer to proceed in the manner chosen by Customer on the Order of Material Handling Services/Straight Bill of Lading, if one has been completed, or otherwise to ship Customer Goods at the discretion of GES and at Customer's expense. GES shall incur no liability for such shipment. GES retains the right to dispose of Customer Goods without liability if left on the show floor unattended, without labels or not correctly labeled.
- i. Concealed Damage: GES shall not be liable for concealed loss or damage including but not limited to; glass, electronic equipment, prototypes, original art, uncrated Goods, or improperly packaged or labeled Goods.
- j. Unattended Booth: GES shall not be liable for any loss or damage occurring while the Goods are unattended in Customer's booth at any time, including, but not limited to, the time the Goods are delivered to the dock until the time the Goods are received by Customer's chosen carrier. All Material Handling Forms and/or Straight Bills of Lading covering outgoing Goods submitted to GES will be checked at the time of pickup from the booth and corrections to the count or condition will be documented where discrepancies exist.
- k. Hanging items from Booth: Customer shall not hang any articles, merchandise, product, advertisements, or other similar items from GES supplied booth materials (this includes but is not limited to GES panels or pipe and drape), utilized in Customer's own booth set up or in areas occupied by the show organizer or third parties. If Customer does hang any prohibited items, Customer alone shall be held liable for any damages, costs, actions or injuries resulting from the hanging of such item(s). GES shall have no liability for any damages, costs, actions or injuries arising out of Customer's failure to comply with this provision.

VII. Measure of Damage

- a. Sole Relief: If found liable for any loss, GES' sole and exclusive maximum liability for loss or damage to Customer's Goods is limited to \$.50 (USD) per pound with a maximum liability of \$100.00 (USD) per container, or \$1,500.00 (USD) per shipment whichever is less.
- b. Labor: GES assumes no liability for loss, damage, or bodily injury arising out of Customer's supervision of GES provided union labor. If GES supervises labor for a fee, GES shall be liable only for actions or claims arising out of its negligent supervision. Such liability shall be limited to the cost to Customer of the supervised labor or the depreciated value of the Goods, whichever is less. If Customer elects to use unsupervised labor, then Customer assumes all liability for the actions or claims that arise out of such work, including but not limited to loss, damage or bodily injury and shall provide GES and show management with an indemnity, including defense costs, for any claims that result from Customers' supervision or failure to supervise assigned labor.

VIII. Miscellaneous

- a. Insurance: GES is not an insurance company and does not offer or provide insurance. It is the obligation of Customer to ensure Goods are insured at all times. Loss or theft of the Goods in storage or in transit to and from the show and or while on the show floor is the sole responsibility of Customer. GES recommends Customer arrange for all Risk Coverage.
- b. Notice of Loss or Damage: In order to have a valid claim, notice of loss or damage to Goods must be given to GES or its agent within 24 hours of occurrence (as evidenced in an Incident Report completed at Show Site by GES) or delivery of outbound Goods.
- c. Filing of Claim: Any claim for loss or damage to Goods must be in writing, containing facts sufficient to identify the Goods, asserting liability for alleged loss or damage, and making claim for the payment of a specified or determinable amount of money. Such claim must be filed with the appropriate party within the time limits specified herein. Damage reports, incident reports, inspection reports, notations of shortage or damage on freight bills or other documents, do not constitute filing of a claim.
Claims for Goods alleged to be lost, stolen or damaged at the Show Site must be received in writing by GES within thirty (30) days after the close of the show. Claims for Goods alleged to be lost or damaged during transit must be received by the responsible party within nine (9) months of date of delivery of Goods. GES Logistics subcontracts the movement of Goods to third party carriers. Claims for damage in transit should be made directly with your carrier as shown on the Material Handling form/ Bill of Lading.
In the event of a dispute with GES, Customer will not withhold payment or any amount due GES for Services as an offset against the amount of the alleged loss or damage. Customer agrees to pay GES prior to the close of the show for all such charges and further agrees that any claim Customer may have against GES shall be pursued independently by Customer as a separate action to be resolved on its own merits. GES retains the right to pursue collection on amounts owed after show close, without regard to any amount alleged to be owed for damage, or loss.
- d. Filing of Suit: Any action at law regarding loss or damage to Goods must be filed within one (1) year of the date of declination of any part of a claim (logistics claims excluded).

G-7 062116 101116 061600445

IX. Jurisdiction, Choice of Forum

These Terms and Conditions of Contract shall be governed by and construed in accordance with the applicable laws of the United States or, alternatively, and depending on jurisdiction, the laws of the State of Nevada. The parties hereby submit to jurisdiction and venue in the United States Federal District Court of Nevada, or as applicable depending upon jurisdiction, the County Circuit Court in Clark County, Nevada.

X. Advanced Warehousing/Temporary Storage/Long Term Storage

All terms and conditions relative to Advanced Warehousing/Temporary Storage/Long Term Storage are contained in separate agreements titled "Storage Agreement." In the event that a Storage Agreement is not executed between the parties, the following shall apply with respect to GES' liability for Customer Goods. The responsibility of GES with respect to Customer Goods is limited to the exercise of ordinary care and diligence in handling and storing of Customer Goods. GES shall be liable only for loss or damage to Goods caused by GES' sole negligence. GES' liability is limited to \$.60 (USD) per pound with a maximum liability of \$100.00 (USD) per container, or \$1,500.00 (USD) per shipment whichever is less. In case of partial loss or damage, the maximum liability shall be prorated based on weight. GES is not responsible for any loss or damage to Goods caused by, but not limited to fire, theft, the elements, vandalism, moisture, vermin, mechanical breakdown or failure, freezing or changes in temperature, as well as any other causes beyond GES' immediate control. GES is not responsible for the marring, scratching or breakage of glass or other fragile items. GES is not liable for the mechanical functions of instruments or appliances even if such articles are packed or unpacked by GES. In no event shall GES be liable for special, incidental, indirect or consequential damages, including business loss of any kind, resulting from any damage to or loss of the Goods or from any act or failure to act. Customer pays storage fees or costs for advance warehousing for use of the space only. There is no guarantee of security or representations made by GES as to appropriateness of the conditions for Customer Goods. The risk of loss remains Customer's alone and GES recommends the Customer carry and maintain insurance in amounts sufficient to cover its risk.

XI. Personal Data

Customer authorizes GES to use personal information ("PI") submitted to GES in connection with the Show as follows: (a) GES stores, processes and transmits credit card information only in compliance with Payment Card Industry Data Security Standards security requirements; (b) GES stores credit card information through its expiration date to better serve Customer's future event needs, unless Customer instructs GES to delete it earlier; (c) GES uses PI only as necessary to administer orders for the Show but otherwise does not disclose PI without either Customer's express authorization or a mandatory legal requirement; (d) GES retains PI of Customer's primary contacts (including name and email) on an ongoing basis to better serve Customer's future event needs until either GES' Privacy Policy requires or Customer instructs GES to delete it; and (e) GES securely stores PI including credit card information on servers located in the United States. GES protects PI with technical, organizational and other safeguards in conformity with applicable data protection laws including, without limitation, privacy laws of European Union countries. If Customer provides GES with PI of a European Union resident, then Customer warrants that it is authorized to do so for the above purposes and the parties agree to cooperate by executing further agreements as required by applicable law. Data subjects have the right to access, amend and oppose the use of their PI. GES may be contacted as provided in its Privacy Policy published at <http://www.ges.com/us/legal/privacy-policy>.

Additional Service Order Forms

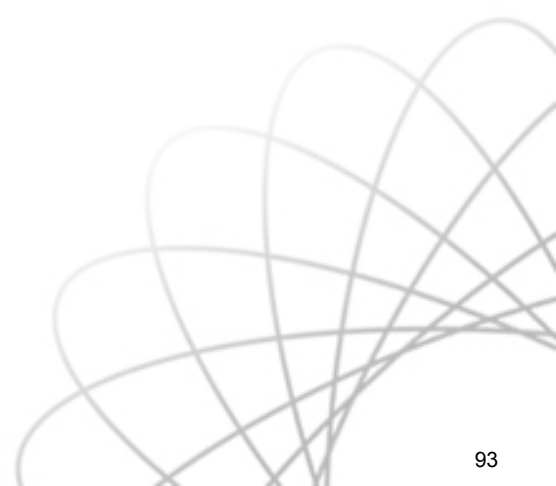

ELECTRICAL ORDER FORM

Advance Payment Deadline Date: 10/10/16

E M



ELECTRICAL EXHIBITION SERVICES
 5931 4th Avenue South, Seattle, WA 98108
 Ph: (206) 781-2411 Fax: (206) 781-2270
 Seattle@edlen.com

COMPANY:		BTH #	
EVENT:	Seattle International Auto Show 2016		
FACILITY:	CENTURY LINK FIELD EVENT CENTER		
DATES:	November 10 -13, 2016	Event #	116040SE

FOR YOUR CONVENIENCE PLACE YOUR ORDER ONLINE AT WWW.EDLEN.COM

ORDER INSTRUCTIONS
<p>120 VOLT POWER DELIVERY The cost of one 120-Volt outlet includes delivery to the rear-center of inline or peninsula booths. If you require an outlet distributed to any other location, material and labor charges apply. There is a minimum charge of 1 hour for installation & 1/2 hour for removal. Complete and return the Electrical Labor Order Form along with a floor plan layout of your booth space indicating outlet locations.</p>
<p>208/480V POWER DELIVERY AND CONNECTIONS The delivery and connection of high voltage services is done on a time and material basis. There is a minimum 1 hour for installation & 1/2 hour for removal. Edlen electricians must make all high voltage connections and disconnects. Please complete the Electrical Labor Order Form to schedule your estimated connection time and return it with this order.</p>
<p>ISLAND BOOTHS Include a floor plan layout of your booth space indicating all outlet locations with measurements and orientation. There is a minimum labor charge of (1) hour to deliver power to all Island Booths. All additional distribution is done by Edlen electricians on a time and material basis. Complete and return the Electrical Labor Order Form along with a floor plan layout of your booth space indicating outlet locations and booth orientation.</p>
<p>24 HOUR SERVICES Electricity will be turned on within 30 minutes of show opening and off within 30 minutes of show closing, show days only. If you require power at any other time order 24 hour power at double the outlet rate.</p>
<p>DEDICATED OUTLETS For a dedicated outlet order a 20 amp outlet.</p>
<p>MATERIAL DELIVERY Material requested on this order form must be picked up by the exhibitor at the Edlen service desk on show site.</p>
<p>CANCELLATIONS Credits will not be made for services delivered and not used. See back of form for additional details.</p>
<p>TERMS & CONDITIONS I agree in placing this order that I have accepted Edlen's payment policy and the terms and conditions of contract.</p>
<p>Form 120/208-061314SE/CLF</p>

ELECTRICAL OUTLETS <small>Approximately 120V/208V A.C. 60 Cycle - Prices are for entire event</small>					
	QTY Show Hours Only	QTY 24hrs/day Double Rate	ADVANCE PAYMENT PRICE	REGULAR PAYMENT PRICE	TOTAL COST
120 VOLT					
500 WATTS (5 AMPS)	_____	_____	84.00	126.00	_____
1000 WATTS (10 AMPS)	_____	_____	116.00	174.00	_____
1500 WATTS (15 AMPS)	_____	_____	138.00	207.00	_____
2000 WATTS (20 AMPS)	_____	_____	158.00	237.00	_____
208 VOLT SINGLE PHASE					
20 AMPS	_____	_____	190.00	285.00	_____
30 AMPS	_____	_____	240.00	360.00	_____
60 AMPS	_____	_____	402.00	630.00	_____
100 AMPS	_____	_____	534.00	802.00	_____
208 VOLT THREE PHASE					
20 AMPS	_____	_____	290.00	430.00	_____
30 AMPS	_____	_____	365.00	520.00	_____
60 AMPS	_____	_____	530.00	800.00	_____
100 AMPS	_____	_____	702.00	1053.00	_____
200 AMPS	_____	_____	1090.00	1635.00	_____
LIGHTS <small>(Cost of arm and pole lights includes power and 1hr labor to install/remove)</small>					
Arm Light	_____	_____	82.00	120.00	_____
8' Pole Light with 1 fixture	_____	_____	55.00	80.00	_____
8' Pole Light with 2 fixtures	_____	_____	69.00	103.00	_____
1000 Watt Overhead Quartz Light Package*	_____	_____	650.00	850.00	_____
*Package price includes 1 quartz light, installation, lift, one focus, and dismantle					
MATERIAL RENTAL <small>(Exhibitor must pick up items at electrical service center on show site)</small>					
15' EXTENSION CORD	_____	_____		25.00	_____
POWER STRIP	_____	_____		21.00	_____
ELECTRICAL LABOR					
ST (Mon-Fri, 8am-4:30pm, excluding holidays)	_____	_____		94.00	_____
OT (Mon-Fri, 4:30pm-8am, all day Sat. & Sun.)	_____	_____		141.00	_____
DT (All day on Holidays)	_____	_____		188.00	_____
SUB TOTAL			_____		
SALES TAX IS DUE UNLESS EXEMPTION CERTIFICATE ACCOMPANIES					
ORDER:			Local sales tax rate is 9.6%		
PLACE TOTAL HERE			_____		
PRINT NAME: _____					
AUTHORIZED SIGNATURE: _____					
EMAIL: _____			PHONE #: _____		
The "Method of Payment Form" must be completed and returned with this order form.					

TERMS & CONDITIONS

1. Order with payment & floor plan (for island booths or any booth requiring distribution of electrical services or location for lights or lighting) must be received no later than the deadline date on the front of this form for advance payment rates to apply. Orders faxed or mailed without payment and required floor plan will not be guaranteed advance rates. Orders received after the deadline date will be charged at the regular rate. A purchase order or photocopy of a check are not considered valid forms of payment for securing advanced rate.
2. In the event order totals are calculated incorrectly, Edlen reserves the right to make the necessary corrections and charge the corrected amount. Exhibitors will be notified by email or fax of any such corrections.
3. Outlet rates listed include bringing the services to one location in island booths and to one location at the rear of in-line and peninsula booths.
4. Outlet rates listed **do not** include the connection of any equipment, special wiring, or distribution of the outlets to other location's within the booth space. Distribution to all other locations *regardless of booth type* require labor and is performed on a time and material basis. Exhibitors are invited to contact the local Edlen office to discuss any additional costs that may be incurred.
5. A separate outlet must be ordered for each location where an electrical service is required. 5 amps or 500 watts is the minimum amount of power that can be ordered for any one location. Power must be ordered according to peak amperage ratings.
6. Island booths - If a floor plan showing main power location is not submitted to Edlen prior to our first move-in date, Edlen will deliver the power to the most convenient location.
7. Labor rates are based on current wage scales and are subject to change in the event of a wage increase after rates have been published. A minimum charge of (1) hour labor will apply for all installation work. The removal of this work will be charged a minimum of 1/2 hour or 1/2 the total time of installation.
8. In the event 1000 watt overhead quartz lights cannot be mounted to existing catwalks in the convention hall, lift and labor charges will apply. Please contact our local office to discuss any additional charges.
9. Edlen employees are authorized to cut floor coverings when essential for installation of services unless otherwise directed.
10. Edlen is the exclusive provider of all material and equipment used in the distribution of temporary electrical services throughout the exhibit hall including the exhibitors booth space. This material is provided on a rental basis ONLY and remains the property of Edlen. It shall be removed only by Edlen employees.
11. Any extension cords or power strips ordered on the front of this form should be picked up at the service desk. Credit will not be not issued for unused items.
12. Standard wall and other permanent building utility outlets or sockets are not part of a booth space and may not be used by exhibitors unless electrical services have been ordered through Edlen.
13. All equipment regardless of source of power, must comply with federal, state and local codes. Edlen reserves the right to inspect all electrical devices and connections to ensure compliance with all codes, for which labor charges can be incurred. Edlen is required to refuse connections where the Exhibitor wiring or equipment is not in accordance with electrical codes.
14. All electrical equipment must be properly tagged and wired with complete information as to the type of current, voltage, phase, cycle, horsepower, etc., required for operation.
15. All Exhibitors' cords must be a minimum of 14 gauge, 3 wire and grounded. Two (2) wire extension cords are not allowed. All exposed, non-current carrying metal parts of fixed equipment which are liable to be energized, shall be grounded.
16. Payment in full must be rendered during the event. Exhibitors ARE NOT billed for services provided. Services may be interrupted if payment is not received.
17. Credit will not be given for services installed and not used. All orders are subject to a 25% cancellation fee if cancelled in writing & received by Edlen within 14 calendar days prior to show opening. Except sales tax, Edlen will not refund overpayment in amounts less than \$50.00 unless specifically requested in writing.
18. Claims will not be considered or adjustments made unless filed in writing by Exhibitor prior to the close of the event.
19. Exhibitor holds Edlen harmless for any and all losses of power beyond Edlen's control, including, but not limited to, losses due to utility company failure, permanent power distribution failure, power failure caused by vandalism, faulty Exhibitor equipment or overloads caused by Exhibitor.
20. It is agreed that in the event it becomes necessary to turn this matter over to an attorney for collection, or to file a lien, or foreclosure, or otherwise, Exhibitor will pay Edlen its attorney fees or applicable agency fees.
21. A service charge of 1.5% per month on any unpaid balances will be assessed starting 10 days after date of invoice. A \$25.00 service charge will be assessed for all returned checks and credit cards. Exhibitor agrees to reimburse Edlen for all applicable rental taxes.
22. By signing this and/or the Method of Payment form, exhibitor hereby agrees to all terms and conditions on this order form.

COMMONLY ASKED QUESTION - WHERE WILL MY OUTLET BE LOCATED?

Outlets are located as depicted below for inline & peninsula booths. All other locations require labor on a time & material basis. Exhibitors with hard wall booths must make arrangements with Edlen to bring power inside the booth on a time and material basis.

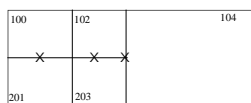

(IN-LINE BTHS) (PENINSULA)

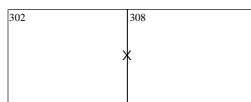

(BACK TO BACK PENINSULAS)

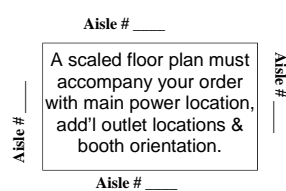

ISLAND BOOTHS

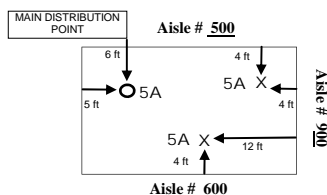

EXAMPLE-FLOOR POWER

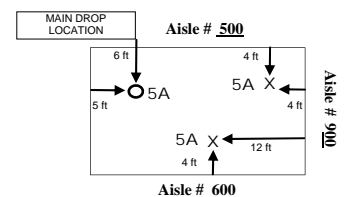

EXAMPLE-CEILING POWER

**FOR OTHER COMMONLY ASKED QUESTIONS VISIT OUR WEB SITE @ WWW.EDLEN.COM
OR CALL THE NUMBER ON THE FRONT OF THIS FORM.**

ELECTRICAL LABOR FORM

Advance Payment Deadline Date: 10/10/16



ELECTRICAL EXHIBITION SERVICES
 5931 4th Avenue South, Seattle, WA 98108
 Ph: (206) 781-2411 Fax: (206) 781-2270
 Seattle@edlen.com

COMPANY:		BTH #	
EVENT:	Seattle International Auto Show 2016		
FACILITY:	CENTURYLINK FIELD EVENT CENTER		
DATES:	November 10 –13, 2016	Event #	116040SE

ELECTRICAL JURISDICTION

The work described below falls within the jurisdiction of the electrical union and cannot be performed by any other union, I&D house or exhibitor. Please feel free to contact our office for clarification of scope of work.

ELECTRICAL LABOR IS REQUIRED FOR THE FOLLOWING WORK

- | | |
|---|---|
| 1. Electrical distribution under carpet and flooring | 4. Wiring of overhead signs |
| 2. Electrical distribution overhead and/or through booth structure | 5. Hardwiring of any electrical apparatus |
| 3. Connection and hard-wiring of all 208V or higher services, electrical motors, dimmers, disconnects or sound and projection equipment | 6. Conductor for installation of electrical signs and/or rotators |

POWER DISTRIBUTION - PLEASE PROVIDE THE FOLLOWING INFORMATION

- Floor Plan layout of your booth space:
 - Floor plans must include exact outlet locations with dimensions or be to scale.
 - Floor plans must reflect booth orientation. Please note surrounding booth or aisle numbers.
 - Power comes from the floor. Identify a main power location we can deliver the power to. Power is distributed from that point.

Example: 20x30 Island Booth

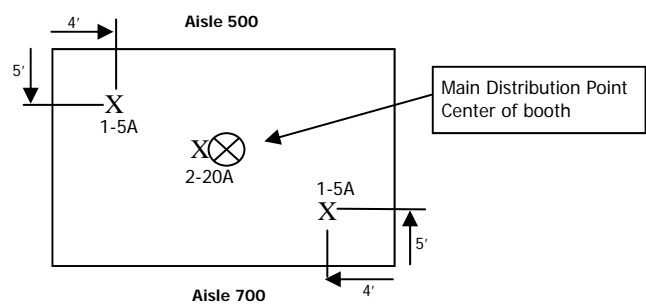

- Date you will begin building your booth _____ Estimated time _____
- Show Site Contact with authority to make additions or changes to your order
 Contact Name _____
 Contact Company _____
 Contact Cell # _____
- Credit card information must be on file before any labor begins in your booth space. Please provide this information on your method of payment form.

PLEASE USE THE BACK OF THIS FORM TO REQUEST ALL OTHER ELECTRICAL LABOR

ELECTRICAL LABOR FORM

Advance Payment Deadline Date: 10/10/16



ELECTRICAL EXHIBITION SERVICES
 5931 4th Avenue South, Seattle, WA 98108
 Ph: (206) 781-2411 Fax: (206) 781-2270
 Seattle@edlen.com

COMPANY:		BTH #	
EVENT:	Seattle International Auto Show 2016		
FACILITY:	CENTURYLINK FIELD EVENT CENTER		
DATES:	November 10 –13, 2016	Event #	116040SE

ELECTRICAL LABOR/LIFT RATES & RULES

Please be advised that labor start times cannot be guaranteed. If no time is provided, work will be performed on a first-come first-serve basis. A representative must come to Edlen's Labor Desk prior to each individual labor call to confirm that booth is ready for such labor. If labor is dispatched at the requested time and no "exhibitor supervisor" is available, a minimum 1/2 hour labor charge per electrician will apply. A minimum labor charge of 1 hour will apply per man for installation. Dismantle time will be calculated at 1/2 of the total installation time.

LABOR RATES

Straight Time 94.00 per hour
 Monday-Friday 8:00am - 4:30pm, excluding holidays

Over Time 141.00 per hour
 Monday-Friday 4:30pm - 8:00am, all day Saturday & Sunday

Double Time 188.00 per hour
 All day on holidays

LIFT RATES

Lift 100.00 per hour

Lift charges will apply to for all overhead work such as; light installation overhead, power or data cable distribution overhead, hanging signs, etc. Lift cost does not include operator.

LABOR REQUIRMENTS (Please complete all the sections below)

If you require any additional electrical work in your booth, please provide us with a production schedule with the dates, times, number of men required and the type of work requested. This will assist us in accommodating your labor needs.

Example

Day	Monday	Date	1/5	# Men	4	Time	8:00 am	Work required	Assemble & hang truss/lights
Day	Tuesday	Date	1/6	# Men	1	Time	12:30pm	Work required	Wire electric sign

Day	_____	Date	_____	# Men	_____	Time	_____	Work required	_____
Day	_____	Date	_____	# Men	_____	Time	_____	Work required	_____
Day	_____	Date	_____	# Men	_____	Time	_____	Work required	_____
Day	_____	Date	_____	# Men	_____	Time	_____	Work required	_____

SHOW SITE SUPERVISOR

Contact Name: _____	Company: _____
Cell Number: _____	Email address: _____

PLEASE PROVIDE CREDIT CARD INFORMATION ON THE METHOD OF PAYMENT FORM

Credit card information must be on file before any of the requested labor is performed.

METHOD OF PAYMENT FORM

Advance Payment Deadline Date: 10/10/16



ELECTRICAL EXHIBITION SERVICES
 5931 4th Avenue South, Seattle, WA 98108
 Ph: (206) 781-2411 Fax: (206) 781-2270
 Seattle@edlen.com

COMPANY:		BTH #	
EVENT:	Seattle International Auto Show 2016		
FACILITY:	CENTURYLINK FIELD EVENT CENTER		
DATES:	November 10 -13, 2016	Event #	116040SE

EXHIBITOR INFORMATION

COMPANY NAME:		PHONE:	
ADDRESS:		FAX:	
CITY:	ST:	ZIP:	
COUNTRY:		CELL:	
EMAIL:			

METHOD OF PAYMENT

All transactions require a credit card on file with proper authorization. In addition to checks, Edlen also accepts American Express, Master Card, Visa, Discover and Wire Transfers. Indicate form of payment below.

COMPANY CHECK
 Please make check payable to: Edlen Electrical. All foreign checks must be drawn on U.S. Banks only. Please reference the Event # listed above on your remittance.

BANK WIRE TRANSFER INFORMATION *
 Bank transfer to Bank of America
Wire Transfer:
 ABA#: 026009593 Acct: 33855214
International Wire Transfer:
 Swift Code: BOFAUS3N Acct: 33855214
ACH Direct Deposit
 ABA# 125000024 Acct: 33855214

CREDIT CARD
 For your convenience, we will use this authorization to charge any remaining balances on your account prior to event closing. A copy of final charges will be sent to the email address provided in the payment information section.

* \$25 processing fee **MUST** be included with transfer.

VISA **MASTERCARD**

AMX **DISCOVER**

CHECK AND CREDIT CARD INFORMATION

CHECK #											
CREDIT CARD NUMBER:										EXP DATE:	
CARD HOLDER SIGN:						PRINT NAME:					
EMAIL ADDRESS:										THIRD PARTY: YES or NO	
CREDIT CARD ADDRESS INFORMATION IF DIFFERENT THAN INFORMATION ABOVE											
ADDRESS:				CITY:				ST:		ZIP:	

By signing and placing this order, I accept all payment policies and the terms and conditions outlined on all service order forms completed.

PLEASE SIGN

 AUTHORIZED SIGNATURE

 PRINT NAME

 DATE

SERVICE TOTALS

ELECTRICAL/LABOR/MATERIAL	
PLUMBING	
LIGHTING	
SUB TOTAL	
9.6% SALES TAX	
TOTAL DUE	

Attention Exhibitor - Urgent Notice: 24-Hour Power Seattle International Auto Show 2016

It is important for businesses to meet the needs of the present without compromising the potential of future generations to meet their needs. This philosophy has been the focus of Edlen Electrical Exhibition Services "Green" policies in respect to both trade shows and exhibits and within our own offices.

In working with the CenturyLink Field Event Center on energy conservation, Edlen is required to turn off all exhibit hall power 30 minutes after the show closes each day and turn it back on 30 minutes before show opens. Exhibitor participation is appreciated in turning off the power in your booth at the close of each day. **Power will be cut off to your booth unless you order 24-hour power. Edlen recommends that exhibitors shut off power to any devices in their booth at show closing, especially computers.**

If you require your power to be left on 24 hours a day please be sure to mark this on your order form. If you have already placed your order with us, you may send in a revised order adding 24 hour power to your order.

Please note that power is left on during show move-in to allow for early morning and late night booth work.

If you have any questions or concerns please feel free to contact our offices at 206-781-2411, by fax at 206-781-2270 or by email at Seattle@edlen.com so that we may assist you.

Thank you for your cooperation.

Edlen Electrical Exhibition Services
Seattle, Washington

5931 4th Avenue South
Seattle, WA 98108
P (206) 781 - 2411
F (206) 781 - 2270

CenturyLink Field Event Center

Network Service Order Form



Event Name		Event Date	
Exhibiting Firm Name		Ordered/Authorized By	
Booth #		Email	
Contact Address		City, State, Zip	
Telephone		Mobile Phone	
Email			

Service Item	Booth #	Quantity	Discount**	Standard	Total
ISDN Radio Line			\$300	\$350	
Standard Voice Line (and credit card, fax)			\$200	\$250	
Internet Connection (Hard line)			\$400	\$500	
Internet Connection (10MB hard line)			\$900	\$1000	
Additional Internet Connection (in booth)			\$100	\$150	
Custom SSID and Splash Page				\$2,500	
Misc. Services (Static IP, Technical Support)				Email	
Sub Total					
WA State Tax 9.5%					
Total					

** Discounted rate for orders received 14 days prior to event

We will contact you for your payment information once your order has been received.

Payment Options	<input type="checkbox"/> Visa <input type="checkbox"/> MC <input type="checkbox"/> AMEX <input type="checkbox"/> Check <input type="checkbox"/> Other
-----------------	---

Please Mail to	CenturyLink Field Event Center Attn: Stadium IT 800 Occidental Ave Suite 200 Seattle, WA 98134	Phone: (206) 381 - 7669 Email: StadiumIT@SeahawksFGI.com
-----------------------	---	--

FIRST AND GOAL, INC.

NETWORK SERVICES TERMS AND CONDITIONS

CONDITION FOR PROCESSING SERVICE ORDER FORM:

Payment (in US dollars) for ALL services must accompany Service Order Form, or service requested cannot be activated. Booth/room number (s) must be identified on Service Order Form. Placement of data connections in a booth/room must be accompanied by a floor plan provided by the client, or First and Goal, Inc. will place connections in the rear of booths that are in rows or in the center of island booths. A client requesting a longer line cord may purchase one from First and Goal, Inc. for \$1.00/foot. Incomplete Service Order Form will delay processing.

EQUIPMENT PROCEDURES:

Clients requesting shared or dedicated Ethernet service will receive a standard RJ-45 jack as part of the contract pricing. Clients are responsible for the protection and safe keeping of any equipment issued by or rented from First and Goal, Inc. Lost, stolen or damaged equipment will be charged to the client at prevailing rates, including line cords provided by First and Goal, Inc.

PAYMENTS AND REFUNDS:

All clients must complete the "Payment Options" section on the front of this form, and submit credit card authorization information. For customers paying by credit card, the signing of this form constitutes authorization for ALL services ordered. For clients prepaying by check, balances due over and above the amount of prepayment will be charged to the referenced credit card.

There will be a \$50 service charge for any checks returned. If a check is returned for any reason, a cashier's check, money order, or valid credit card can only replace it. There will be a \$50 service charge added if payment is wire transferred to First and Goal, Inc.

A monthly service charge of 1.5% will be added to invoices 30 days past due.

Refunds, after installation – NO REFUNDS

There is a minimum \$100.00 cancellation charge per data line when cancelled less than 10 days prior to event start date.

ONLY FIRST AND GOAL, INC. PERSONNEL are authorized to modify system wiring or cabling. Material and equipment furnished for this service contract shall remain property of First and Goal, Inc.

COMPLETION OF SIGNED SERVICE ORDER FORM constitutes authorization to proceed with work necessary to accomplish the services ordered and handle negotiations for the installation of the service. This includes arranging for disconnection's or rearrangements of service and equipment as appropriate.

CLIENT CONTRACTING For services from First and Goal, Inc. agrees to indemnify and hold and save whole and harmless, First and Goal, Inc., its employees and/or its subcontractors from and against any and all loss, damage or injury to person or property arising from or related to customer and its employees, guests, invitees, or agents use of Internet services from First and Goal, Inc. unless such loss, the sole negligence, gross negligence or willful misconduct of First and Goal, Inc., its employees and/or its subcontractors cause damage or injury.

FIRST AND GOAL, INC. is not responsible for loss of communication services caused by local and/or long distance carriers. **FIRST AND GOAL, INC. CANNOT GUARANTEE** the security of proprietary information carried on lines installed by First and Goal, Inc. and/or its subcontractors. Wi-Fi service is provided on an as-is basis subject to signal degradation and weak signal areas.

FIRST AND GOAL, INC. OBLIGATIONS UNDER this agreement are subject to, and First and Goal, Inc. and/or its subcontractors shall not be liable for delays, failure to perform, or destruction or malfunction of the equipment and services. Also, any consequences of the above, caused, occasioned or due to fire, flood, water, the elements, labor disputes or shortages, utility curtailments, power failure explosions, civic disturbances, government regulatory requirements, acts of God or public enemy, war, military or governments requisitions, shortage of equipment or supplies, unavailability of transportation, act or omissions of anyone other than First and Goal, Inc., its representatives, agents, subcontractors, or employees, or any other cause beyond First and Goal, Inc.' reasonable control.

INTERNET SERVICE PROVIDERS (ISP'S) for Internet services will be First and Goal, Inc. selected provider(s). Any customer that has equipment that effects other customers will have their service terminated.

INTERNET CLIENT HAS FULL, unrestricted access to the Internet. Matters considered improper, offensive, or even unlawful by groups or individuals are not the responsibility of the Internet Service Provider (s) and/or First and Goal, Inc. Subscribers agree to indemnify and hold and save whole and harmless Internet Service Provider(s) and First and Goal, Inc. from and/all problems, and damages resulting from translation of services.

COMMUNICATION SERVICES ARE TO BE ordered by each client separately, and is not to be shared with other customers. Any client sharing communication services without written authorization from First and Goal, Inc. shall be charged for that service on a full and complete second Service Order Form.

Stadium Public WiFi

Broadcast Name: Stadium Public WiFi

Select: [Accept]

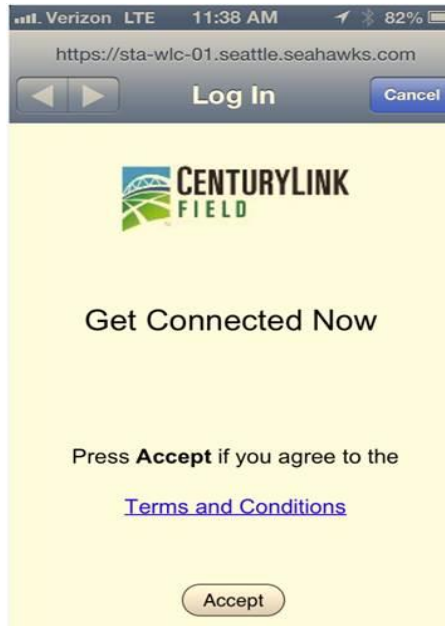

Troubleshooting:

- Restart device, confirm wireless is turned on and re-connect.
- Type: <https://2.2.2.2/login.html> into browser.
- Devices may disconnect during sleep mode, please re-connect.

Common steps to connect:

iPhone:

1. Settings
2. WiFi
3. Select "Stadium Public Wifi"

Android:

1. Apps
2. Settings
3. WiFi
4. "Stadium Public Wifi"

Windows Phone:

1. Start
2. Apps
3. Settings
4. "Stadium Public Wifi"

Support: (206) - 381 - 7669 or email: StadiumIT@SeahawksFGI.com

***Staff does not support customer equipment. Please contact your support team for hardware or configuration issues.



International Wholesale Florist

www.tradeshowflorist.net
 14106 6th Ave. SW Seattle, WA 98166
 Phone: 206-623-2828 / Fax: 206-623-5530
 info@tradeshowflorist.net

Company _____ Booth Number _____ Install Date _____ AM PM
 Street Address _____ City _____ State _____ ZIP _____
 Phone _____ Fax _____ Email _____ PO Number _____
 Event Name _____ Event Date _____ Event Location _____
 Ordered by: _____

- Check Discover American Express
 Visa Mastercard Corporate Personal

Card Number _____ Name on card _____ Exp. Date _____

Flowers and plants say it best! Add flowers and plants to your booth or stage or special event to complete the visual ambiance with style and warmth, thereby providing the finished look that you want to show your guests and customers.

Green Plant Rental

(If not specifically requested, the green plants will be from a selection of Ficus, Schefflera, Palm, Dracaena, Spathiphyllum & others. Decorative containers holding the plants will be assumed to be black contemporary cylinders unless white or terracotta or baskets are requested. Other containers and Bamboo and Northwest trees and foliage are also available upon special request.)

Quantity	Price	TOTAL
_____ 3' Plant	39.50	_____
_____ 4' Plant	49.50	_____
_____ 5' Plant	59.50	_____
_____ 6' Plant	69.50	_____
_____ 7' Plant	79.50	_____
_____ Small Fern (6" Pot) <input type="checkbox"/> Ivy <input type="checkbox"/> table top plant	25.00	_____
_____ Large Fern (10" Pot) <input type="checkbox"/> Ivy <input type="checkbox"/> Pathos	35.00	_____

Blooming Plant Rental

Quantity	Price	TOTAL
_____ Chrysanthemum <input type="checkbox"/> Yellow <input type="checkbox"/> White <input type="checkbox"/> Other*	20.00	_____
_____ Begonia or Kolanchoe <input type="checkbox"/> Red <input type="checkbox"/> Orange <input type="checkbox"/> Other*	25.00	_____
_____ Azalea or Cyclamen <input type="checkbox"/> Red <input type="checkbox"/> Pink <input type="checkbox"/> Other*	30.00	_____
_____ Bromeliad <input type="checkbox"/> Red <input type="checkbox"/> Pink <input type="checkbox"/> Other*	35.00	_____
_____ Hydrangea <input type="checkbox"/> Blue <input type="checkbox"/> Pink <input type="checkbox"/> White	35.00	_____

Fresh Flower Designs

(Unless otherwise specified all arrangements will be designed in a vase with a traditional & colorful all round style)

Quantity	Price	TOTAL
_____ Arrangements, Small (approx. 1 ft. to 1.5 ft.)	45.00	_____
_____ Arrangements, Medium (approx. 1.5 ft. to 2 ft.)	65.00	_____
_____ Arrangements, Large (approx. 2 ft. to 3 ft.)	85.00	_____

For tropical flowers in arrangements, please add \$10.00 dollars and check this box

* Special Requests:

Subtotal	_____
Delivery	\$10.00
9.5% Sales Tax	_____
<i>(Per Washington Law, Delivery is Taxed)</i>	
GRAND TOTAL	_____

Payment Policy: All orders must be paid in full prior to delivery.

Quantity Order Discounts: Available upon request for budgets exceeding \$350.

Rental Policy: Unless other arrangements have been made all items to be left in booth at end of show. All prices include installation, servicing, container, & removal. Substitutions (same size, different plant) may be necessary due to availability and at the discretion of IWF.

Cancellation Policy: Items canceled within three days of the show will be charged at 50% of original order.

Index

All orders are governed by the GES Payment Policy and GES Terms & Conditions of Contract as specified in this Exhibitor Services Manual.

Seattle International Auto Show
CenturyLink Field Event Center
November 10 - 13, 2016

A

Additional Service Order Forms, Page 93

Advance Shipping Labels, Page 58

Agreement and Rules and Regulations
between GES and EAC, Page 81

B

Booth Layout - Hanging Signs, Page 77

C

Carpet Brochure, Page 12

Carpet Order Form, Page 13

Carpet Package Order Form, Page 14

Cartload Service Order Form, Page 66

Certificate of Liability Insurance Sample,
Page 83

Cleaning and Porter Service Order Form,
Page 79

Convenience Package Order Form, Page 36

D

Digital File Preparation, Page 47

Direct Shipping Labels, Page 59

Domestic Third Party Billing Request, Page
10

E

Electrical, Page 94

Electrical 24 Hour Power Notice, Page 100

Exhibitor Appointed Contractors (EACs)
and Third Parties, Page 80

F

Fire Regulation Information, Page 86

Forklift Order Form, Page 70

Freight Service Questionnaire, Page 61

Furniture & Accessories Order Form, Page
17

Furniture Package Order Form, Page 20

G

General Information, Page 6

GES Information and Order Forms, Page 3

GES Payment Policy, Page 89

GES Terms, Page 90

GES Terms and Conditions of Contract,
Page 90

GES Transportation Plus, Page 54

Graphics & Signage Order Form, Page 49

H

Hanging Sign / Truss Labor Information,
Page 72

Hanging Sign Labor Order Form, Page 73

Hanging Sign Shipping Labels, Page 78

I

International 3rd Party Billing Request,
Page 11

L

Labor Information and Regulations, Page 67

M

Marshaling Yard & Direct Deliveries
Information, Page 62

061600445

101116

Index

All orders are governed by the GES Payment Policy and GES Terms & Conditions of Contract as specified in this Exhibitor Services Manual.

Seattle International Auto Show
CenturyLink Field Event Center
November 10 - 13, 2016

Material Handling/Drayage Information, Page 51

Material Handling/Drayage Order Form, Page 55

Move In Routes, Page 63

N

Notice of Intent to Use EAC and Policies and Procedures, Page 80

O

Operation of All Mechanical Lifts, Page 88

P

Payment and Credit Card Charge Authorization, Page 9

Pre-Printed Bill of Lading (BOL) / Outbound Labels Request, Page 60

S

Shipping Labels: Advance, Page 58

Shipping Labels: Direct, Page 59

Show Information, Page 4

Show Site Storage Order Form, Page 64

Show Site Work Rules, Page 84

Special Handling Brochure, Page 57

Specialty Furniture Brochure, Page 21

Specialty Furniture Order Form, Page 30

Standard Exhibit Systems Brochure, Page 38

Standard Exhibit Systems Order Form, Page 45

Standard Furniture Brochure, Page 15

Standard Graphics Brochure, Page 50

Stop. Think. Safety., Page 85

T

Telecom/Internet, Page 101

Tips for New Exhibitors, Page 7

061600445

101116