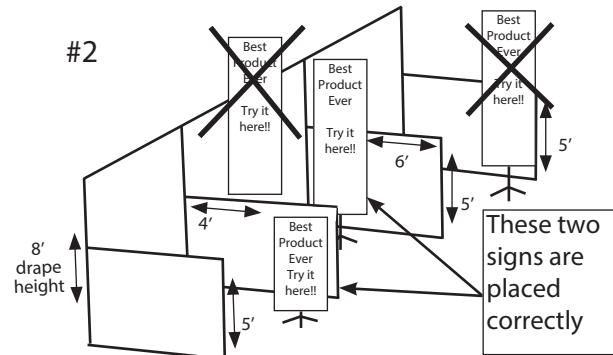
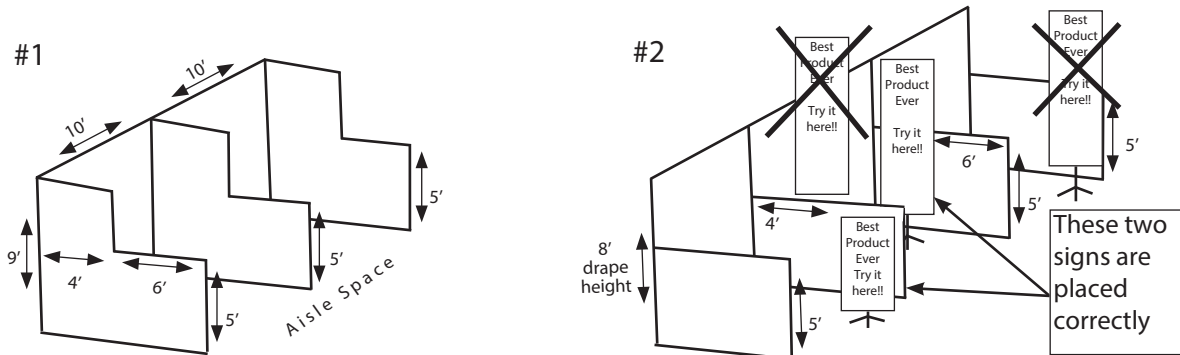

Exhibit Specifications for Inline/Corner 10'x10' Booths

Intent: The following specifications are intended to assure uniformity throughout the show. Deviation from these configurations is not allowed. All exhibiting companies are responsible for booth size and configuration which must fall within the prescribed spatial specifications. Items not meeting IDDBA specifications must be removed. IDDBA will review booths and make the final determination regarding suitability.

Standard Inside Booth (10'x10') - same rules apply to 10'x10' corner booths



- An inside booth (or combination of inside booths) cannot exceed 9' in height along the back wall.
- Any display above the 8' drape must be finished (front and back). You may not show a corporate logo or ID behind your exhibit. As directed by IDDBA Show Management, GES will install masking drape at the exhibitor's expense.
- The side height limit is no more than 5' tall in the front 6' of the booth (see diagrams #1 and #2).
- Any use of pop-up or table top signage must fall within the above height restrictions and not be placed in the aisle space. At show site, exhibitors in violation will receive one written notification to comply with the rule, then the offending signage will be removed until the close of show or covered with masking drape at Show Management's discretion and at the exhibitor's expense (see diagram #2).
- Each exhibitor is entitled to a reasonable sightline from the aisle regardless of the size of their booth.
- Pipe and drape is for the division of the booths and may not be used as part of an exhibitor's structure or support. When using a back drop, the exhibitor must have their own framework to hold it in place.
- All woodwork, stage scenery, furnishings, decorations, and sets used upon a working permanent or temporary stage, or within an exhibit, shall be coated or treated by approved methods to render them fire retardant. All fabrics, films, draperies, curtains, and similar furnishings must be flame resistant. Acoustical and decorative material including, but not limited to, cotton, foamed plastic, hay, paper, wood chips, split bamboo, and thatch must be flame retardant treated. Mulch and straw cannot successfully be treated with a flame retardant. The use of styromfoam products for set construction is not permitted. All exhibits and displays are subject to inspection by the Fire Marshal and the Convention Center for compliance.
- Inline booths shall not be constructed with any roof, ceiling, canopy, tent, awning or other enclosure which would prevent the sprinkler system from protecting the covered booth area without prior approval from IDDBA, Convention Center, and the Fire Marshal.
- Any and all matters not specifically covered by the preceding rules and regulations shall be subject solely to the decision of IDDBA Show Management.
- The above rules and regulations apply to all 10'x10' inline and corner booths.

Common Areas:

Aisle space shall not be used for exhibit purposes, demonstrations, sampling, display signs, solicitations, or distribution of promotional material. Exhibitors may not use floor space outside of their allotted booth space, which includes exhibit staff, demonstrators, and costumed characters. Exhibits, signs, and displays are also prohibited in any of the common public spaces on the premises of the Convention Center.

Exhibit Specifications for Peninsula Booths - 10x20 - 10x60

Intent: The following specifications are intended to assure uniformity throughout the show. Deviation from these configurations is not allowed. All exhibiting companies are responsible for booth size and configuration which must fall within the prescribed spatial specifications. Items not meeting IDDBA specifications must be removed. IDDBA will review booths and make the final determination regarding suitability.

Peninsula or "B" Booth (10'x20' - 10'x60')

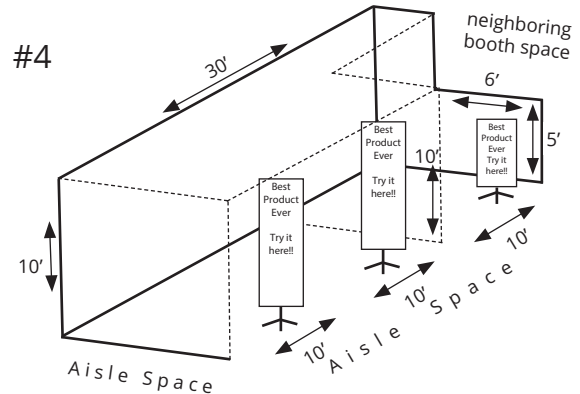
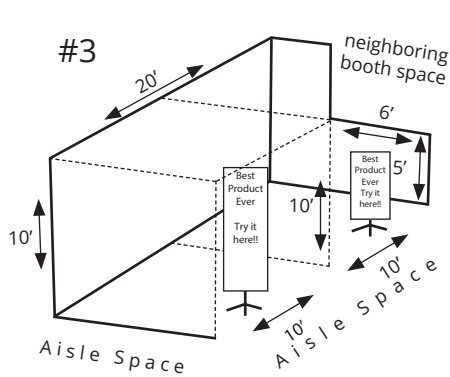

- A peninsula or "B" booth has at least one corner of aisle space.
- A maximum display height of 10' along the back wall is permitted. NO EXCEPTIONS.
- Any display above the 8' drape must be finished (front and back). You may not show a corporate logo or ID behind your exhibit. As directed by IDDBA Show Management, GES will install masking drape at the exhibitor's expense.
- Side height limit is no more than 5' tall in the front 6' of the booth (see diagram #3) on the neighboring booth space.
- Booths 30' or more wide within an aisle may increase the height of the center 10' of the booth space to a maximum of 10' up to the front aisle. There must be 10' of space that meets the 5' height restriction on either side of the booth that has adjoining neighbors (see diagram #4).
- Any use of pop-up or table-top signage must fall within the above height restrictions and not be placed in the aisle space. At show site, exhibitors in violation will receive one written notification to comply with the rule then the offending signage will be removed until the close of the show or covered with masking drape at show management's discretion and at the exhibitor's expense.
- Each exhibitor is entitled to a reasonable sightline from the aisle regardless of the size of their booth. The general rule of thumb is to be a good neighbor.
- All woodwork, stage scenery, furnishings, decorations, and sets used upon a working permanent or temporary stage, or within an exhibit, shall be coated or treated by approved methods to render them fire retardant. All fabrics, films, draperies, curtains, and similar furnishings must be flame resistant. Acoustical and decorative material including, but not limited to, cotton, foamed plastic, hay, paper, wood chips, split bamboo, and thatch must be flame retardant treated. Mulch and straw cannot successfully be treated with a flame retardant. The use of styromfoam products for set construction is not permitted. All exhibits and displays are subject to inspection by the Fire Marshal and/or the Convention Center for compliance.
- Booths shall not be constructed with any roof, ceiling canopy, tent, awning, or other enclosure which would prevent the sprinkler system from protecting the covered booth area without prior approval from IDDBA, the Convention Center and/or the Fire Marshal. Contact IDDBA or details.
- Any and all matters not specifically covered by the preceding rules and regulations shall be subject solely to the decision of IDDBA Show Management.

Common Areas:

Aisle space shall not be used for exhibit purposes, demonstrations, sampling, display signs, solicitations, or distribution of promotional material. Exhibitors may not use floor space outside of their allotted booth space, which includes exhibit staff, demonstrators, and costumed characters. Exhibits, signs, and displays are also prohibited in any of the common public spaces on the premises of the Convention Center.