



Fresh Ideas Organic Marketplace 2016 Exhibitor Service Kit

Thursday March 10th, 12:30pm – 5:30pm

Welcome to the 24th annual Fresh Ideas Organic Marketplace. This Exhibitor Service Kit has been prepared to help you plan for the show. Please read it in its entirety.

We encourage you to complete your badge registration online prior to the show. We no longer mail badges, and registering pre-show can save you valuable time onsite.

If you have questions on any of the enclosed materials, please contact the Client Services Department at 1.303.998.9208 or esk@newhope.com. We look forward to seeing you in Anaheim!

Website access: [Fresh Ideas 2016 Home Page](#)

Need Help? Expo Service Desk 1.303.998.9208, esk@newhope.com

Registration 1.866.458.4935, or 1.303.390.1776

Inclusions

One (1) counter-height skirted table 6'L x 2'W x 42"H

Standard ID sign

One (1) stool

One (1) wastebasket

If you are not exhibiting on the Expo West Show floor, you will receive two (2) complimentary badges to be used at Fresh Ideas and Natural Products Expo West. If you are an Expo West show floor exhibitor, your badges are part of your Expo West allotment. Expo West exhibitors are not given additional badges for exhibiting at Fresh Ideas.

Additional items will be available for rent. Please see the order forms included in this kit for availability.

Parking Guide

Fresh Ideas Organic Marketplace tent is located between the Anaheim Marriott Hotel and the Clarion Hotel.

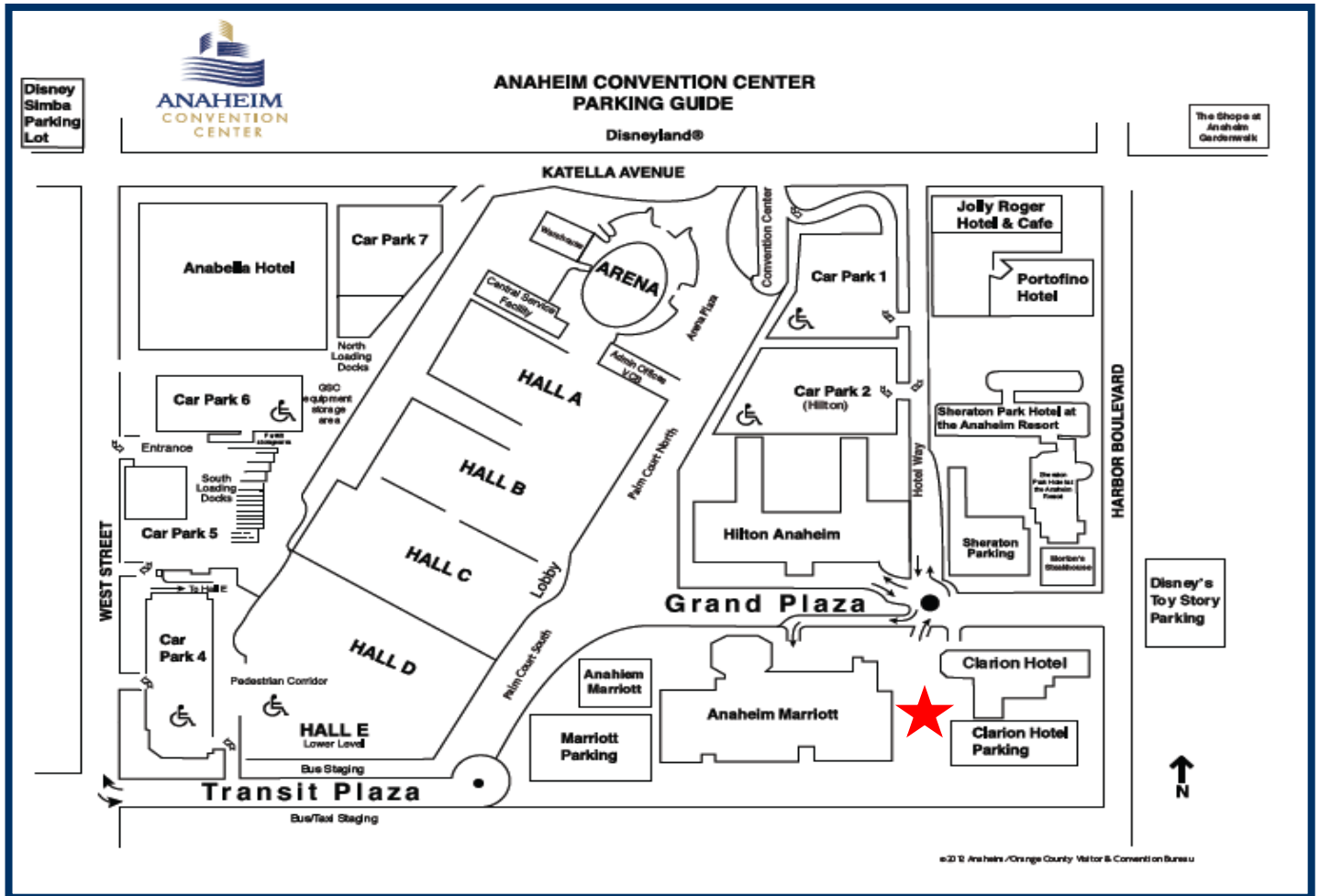

Parking The current parking rate at the Anaheim Convention center during exhibitor move in/move-out is \$15* and includes unlimited in/out privileges on a space available basis. On show days, March 11 – 13, exhibitors and attendees will be charged \$15* for each entry, and, for exhibitors only, this will include in and out privileges through the West Street entrance (exhibitors must present parking receipt and show badge). Overnight parking in the convention center lots is prohibited. For the Anaheim Marriott, daily drive-in rates are as follows: \$40 self-park and \$50 valet. For hotel guests, the rates are \$24 per day/overnight and \$28 for valet per day/overnight guests.

Services & Official Show Vendors

Badge Registration (Over Allotment)	Ph: 1.866.458.4935, 1.303.390.1776 Fax: 1.708.344.4444 tradeshows@newhope.com	Discount Deadline 2/7/16
Electrical	GES Ph: 1.702.515.5970 www.ges.com/chat	Discount Deadline 2/16/2016
Storage Onsite (dry, frozen, refrigerated)	GES Ph: 1.702.515.5970 www.ges.com/chat	Discount Deadline 2/16/2016
Hotel Reservations	Hotel and Travel Information Ph: 1.800.388.8812	As soon as possible!
Shipping Freight Deliveries & Labels	GES Ph. 800-475-2098 Ph: 1.702.515.5970 www.ges.com/chat	Advance: 1/29/16 – 2/29/16 see GES shipping labels for details Direct: 3/9/2016 8:00 am – 4:00 pm see GES shipping labels for details
Promotional & Sponsorship Opportunities	Promotional and Sponsorship Opportunities	Individual deadlines apply!
Environmental Exhibiting/ Greening Efforts	Greening Efforts Ph: 1.303.939.8440	Every Day!
Lead Retrieval Units	CompuSystems, Inc. 1.866.600.5323, 1.708.786.5565 (Outside the U.S.)	Early Bird Deadline—2/15/2016

Exhibit Installation/Dismantling

Thursday, March 10

8:00 am – 11:30 am: all exhibits must be set by 11:30 am

5:30 pm – 7:00 pm: all exhibits must be dismantled by 7:00 pm

Stay with your exhibit until the last item is placed for shipment. If you must leave early, place an order for contractor labor and supervision through GES, so they can pack up your exhibit. Exhibitors are responsible for the removal of all materials at the conclusion of the event. Parking is not permitted adjacent to Fresh Ideas during the event, move-in or move-out.

Height & Space Guidelines

Display space does not extend beyond the table surface. One stool is placed to the side of the table.

TABLETOP HEIGHT: Exhibit fixtures, signage, products, etc. must be placed on top of the tabletop. Signs or banners reaching a maximum of 6'L x 42"H may be hung from the drape on the front of the table. No signs or banners may be hung from the tent or behind your display area. Maximum height permitted on top of the table is 3'0". Exhibitors will be asked to remove any exhibits not in compliance with these guidelines.

Note: You may not attach any display materials to the tent or tent poles. Your tabletop is your only exhibit space. The walls and poles of the tent are not part of your exhibit space and you may be held responsible for damages should you attempt to attach display materials to the tent.

INTENT: Each exhibitor is entitled to a reasonable sightline from the aisle, regardless of the size of the exhibit.

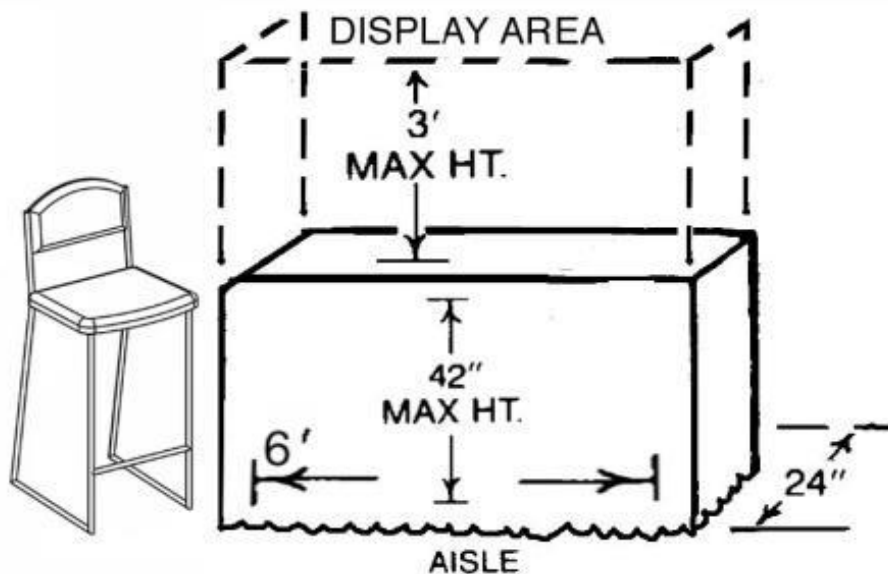

Shipping

Label all boxes "Fresh Ideas Organic Marketplace." Do not send shipments to your Expo West booth. Use the labels provided by GES located in this kit. Please make sure to read the GES service kit for Fresh Ideas in its entirety to prevent any shipping delays.

Advance

Deliveries

We strongly recommend that you ship your booth materials in advance. All event-related freight or materials, whether shipped in advance or direct, must be addressed c/o and delivered to the official service contractor, GES. C.O.D. deliveries will not be accepted.

**Advance
Shipments**

Friday, January 29: Shipments may begin arriving at GES warehouse. Drivers must check in by 2:00 pm to be guaranteed same day unloading. Warehouse receiving hours are Monday – Friday, 8:00 am – 2:00 pm. The warehouse is closed 12:15 pm – 12:45 pm and on holidays.

Please use the attached shipping labels so that your carrier has these times.

Monday, February 29: Deadline for shipments to arrive at GES warehouse.

Send advance shipments to: Name of Exhibiting Company, Natural Products Expo West - Fresh Ideas Organic Marketplace, Tabletop #, c/o Global Experience Specialists, Inc. (GES) 5560 Katella Avenue Cypress, CA 90630

***Important Note: Please ship non-perishable items only, as there is no cold storage for advance shipments to the GES warehouse.**

**Direct
Deliveries**

Wednesday, March 9, 2016 8:00 am – 4:00 pm shipments may arrive directly for Fresh Ideas.

Please use the attached shipping labels so that your carrier has these times.

Send direct shipments to: Name of Exhibiting Company, Fresh Ideas Organic Marketplace, Tabletop # c/o Global Experience Specialists, Inc. (GES), Anaheim Marriott, 700 Convention Way, Anaheim, CA 92802

Drivers must check in between 7:00 am and 8:00am to be guaranteed same day unloading.

Shipping Tips

Make sure your onsite contact has a copy of your BOL to trace lost or delayed shipments. Remove all extraneous shipping labels from your freight prior to shipping. If you need to ship materials home, please fill out the Outbound Material Handling agreement and return it to the GES service representative onsite.

POV (Privately Owned Vehicles) Exhibitors will be permitted to unload their vehicles at the tent. Vehicles must be removed after 15 minutes. Parking is not permitted adjacent to the Fresh Ideas tent during the event, move-in or move-out.

Labor

Should you require assistance setting up or dismantling your tabletop, you may order labor through GES. Exhibitors are requested to conform to union labor regulations. Do not tip in an effort to receive preferential treatment. “NO TIPPING” is the rule for the unions, the Anaheim Marriott Hotel, GES and Natural Product Expo.

Fire Department Regulations

Please make sure you read and understand the Fire and Safety Regulations for Exhibitors as well as the Fire Regulations Information included in the kit.

***Please note Show Management approval is required for any display components mentioned in the Fire Regulations. Additionally, participants are responsible for any fire safety costs related to their display.**

General Conditions

Storage, booth construction, easels, chairs and signs shall not block access to any fire/life safety equipment and shall not impede exit access, exit doors or aisles. Fire equipment, fire strobes, fire speakers, fire signage and fire extinguishers shall not be concealed and shall remain visible and unobstructed at all times.

Storage

Literature on display shall be limited to reasonable quantities. Reserve supplies shall be kept in closed containers and stored in a neat and compact manner. No more than a one (1) day supply of combustible storage is allowed beneath tables and in storage rooms. No storage of any kind will be allowed behind curtains, walls or on electrical cords of booths in any facility.

Decorative Material

Canvas tents, canopies, awnings, curtains, straw, hay, fabrics and materials are required to be flame retardant. A copy of the California State Fire Marshal flame proof certificate must be provided to the Anaheim Fire Department. If a California State Fire Marshal flame proof certificate is not provided, a sample of the material or product must be submitted to the Anaheim Fire Department for fire testing. If at any time it is determined that the material or product is not fire retardant, the materials shall be removed prior to show opening.

Heat-Producing Equipment

Operation of any welding equipment, soldering device, etc. require protection around equipment so the public cannot be injured during demonstration. All items shall be placed on a non-combustible surface. Approved welding screens will be required for welding equipment. (See permit section for use of compressed gases).

Machinery

Operation of any electrical, mechanical, or dust-producing equipment, which incorporates moving parts or could cause injury to the public, requires protection around machinery for the viewers' protection if safeguards are not currently in place. (This does not apply to normal electrical appliances such as lamps, computers, radios, etc.).

Candles

Use of any decorative candles must be securely supported on a substantial non-combustible base so located as to avoid danger of ignition of combustible materials or tipping over. The candle flame shall also be protected by a non-combustible container.

Flammable or Combustible Aerosols/Liquids

Describe the use and amounts for each day of the show on the Show Permit form. Include the Material Safety Data Sheet (MSDS) for the product. Quantities may be limited by the Anaheim Fire Department. All flammable or combustible aerosol containers used for display purposes must be empty.

Hazardous Materials/Compressed Gas

Describe the use and amounts for each day of the show on the Show Permit form. Include the Material Safety Data Sheet (MSDS) for the product. Quantities may be limited by the Anaheim Fire Department. Hazardous materials are defined in the 2007 California Fire Code.

Open Flame

Open flame is not permitted in the Tent.

For further information regarding these requirements contact: Fire Prevention Bureau at (714) 765-4040, between the hours of 8:00 a.m. to 5:00 p.m., Monday through Friday or send an e-mail to tradeshowsinspector@anaheim.net.

Fire and health regulations are strictly enforced. The exhibit area will be inspected by fire marshals and a representative from the health department.

In the Fresh Ideas Organic Marketplace, cooking regulations are restricted for the protection of the public.

Food & Beverage Sampling: Exhibitors that manufacture or distribute food and beverages may sample these products to attendees. There is no longer a recommended sample size for these items. Exhibitors are free to distribute samples in the sizes best suited for their product and packaging. Exhibitors are prohibited from sampling product they do not manufacture or distribute. For example, if you make or distribute veggie burgers, you may not add condiments or buns to the sample. A Product Sampling Form is not required.

Anaheim Marriott holds the alcoholic beverage license for the tent and applies a corkage fee for all alcoholic beverages distributed at the events, and not purchased from the Anaheim Marriott. For more information, call 1.714.748.2492

Health Department

Regulations

All booths providing food samples must do so in a clean and sanitary manner. Tongs, single-serving napkins, toothpicks or dispensing units (i.e. cups, etc.) must be used.

- If preparing or serving any food items, hand-washing facilities are required within each booth. Acceptable facilities include a dispenser of warm water with a catch bucket, paper towels and a pump-type soap dispenser.
- Food may not be served from a "common bowl" unless tongs are used to distribute the food. We suggest single-serve cups, toothpicks and single napkins.
- Even if gloves are used, a hand-washing kit is still required. The sole use of a waterless hand sanitizer is not in compliance with health department regulations.
- All perishable foods such as milk, fish, eggs and poultry products must be temperature controlled. Cold foods must be kept at or below 41 degrees Fahrenheit. All potentially hazardous foods must be maintained at or below 41 degrees Fahrenheit or above 135 degrees Fahrenheit at all times.
- All vendors who wish to sample their product must provide protection of open food sampling (i.e. unpackaged crackers, chips, dips, drinks, etc.). All unpackaged foods on display must be protected with a sneeze guard shield

or plastic covering that is rigid, semi-permanent, and provides adequate protection that follows the Temporary Food Facility Guidelines. Sneeze guards are available for rent from GES.

- All food samples should display a label with its common name and ingredients.

Per the Health Department's advice, you may be asked to cease sampling operation at your booth if you do not meet the requirements. For several years, sneeze guard protection has been required for the protection of open food sampling. This health code is now being enforced if violated.

Personal Care Product Applications

- Sterilized utensils must be used. A fresh, sterilized cotton ball, spatula, Q-tip or powder puff must be used for each individual application.
- When applying lip applications of any kind, eye shadows, face blushes, etc. a portion of the product must be scraped off with a utensil and applied to the individual with the utensil. The used utensil may not be returned to the pallet. A new, sterilized utensil must be used for each application.
- When using products that are packaged in a container other than a squeeze type container, such as a jar, a sterilized utensil must be used to remove the product from the container. Once the product has been applied to the individual, you may not return the used utensil to the product.

Standards An Exhibitor Standards booklet is available online or upon your request. All Fresh Ideas Exhibitor contracts include a clause requiring compliance with the Exhibitor Standards. A signed exhibitor contract is a binding agreement to comply with Natural Product Expo Exhibitor Standards. Companies exhibiting in the Fresh Ideas Organic Marketplace must submit an Organic Standards Form Prior to the show. Standards Booklet/Forms online at www.newhope.com/standards

Storage Empty boxes/freight may be stored under your tabletop out of the view of attendees. Boxes and empty crates are not permitted in front or to the sides of the tabletop space.

GES will have food and beverage storage in coolers and freezers for exhibitors. If you wish to take advantage of this service, call GES at 702.515.5970

Sound/

Noise Levels Sound and noise is permitted up to a maximum of 85 decibels