

2013 Big O Tires Convention

Phoenix Convention Center

April 23, 2013

GES Information and Order Forms	3
General Information	4
G-1: Show Information	4
G-11: General Information	5
G-10: Trade Show Tips	6
G-5: Stop. Think. Safety.	7
G-6: Show Site Work Rules	8
G-7: GES Terms & Conditions of Contract	9
G-8: Fire Regulation Information	10
G-9: Operation of All Mechanical Lifts	11
G-4: Petroleum Surcharge Information	12
L-3: Official Service Provider Information	13
SAMPLE COPY: Certificate of Liability Insurance	14
L-4: Notice of Intent to Use Exhibitor Appointed Contractor	15
Material Handling	16
R-1: Material Handling Information	16
GES Transportation Plus	17
R-2: Material Handling Order Form	18
R-5: Advance Shipping Labels	19
R-6: Direct Shipping Labels	20
R-3: Pre-Printed Outbound Material Handling Request	21
R-8: GES Logistics - Domestic Shipping Quote Form	22
GES Global Transportation Plus	23
R-20: GES Logistics - International Shipping Quote Form	24
R-12: Skid Accessible Storage Order Form	25
R-14: Cartload Service Order Form	26
R-15: Vehicle Placement Order Form	27
Decorating Services	28
Carpet Brochure	28
C-1: Carpet Order Form	30
C-2: Carpet Package Order Form	31
Standard Furniture Brochure	32
A-1: Furniture & Accessories Order Form	34
Specialty Furniture Brochure	35
B-1: Specialty Furniture Order Form	44
B-2: Specialty Furniture Order Form	45
P-1: Convenience Package Order Form	46
Standard Exhibit Systems Brochure	47
D-1: Standard Exhibit Systems Order Form	54
I-2: Digital File Preparation	55

2013 Big O Tires Convention

Phoenix Convention Center

April 23, 2013

I-1: Graphics & Signage Order Form	56
Custom Graphics Brochure	57
Labor Services	58
L-1: Installation & Dismantling Order Form	58
L-2: Key Information\Supervised Labor Checklist	59
T-1: In-Booth Forklift & Labor Order Form	60
H-1: Hanging Sign / Truss Labor Information	61
H-2: Hanging Sign / Truss Labor Order Form	62
H-1a: Hanging Sign Shipping Labels	63
H-8: Sign Hanging & Rigging Indemnification Form	64
J-1: Cleaning Order Form	65
Required Forms	66
G-2: Payment & Credit Card Charge Authorization	66
G-3: 3rd Party Billing Request	67
H-3: Booth Layout Form	68
Additional Service Order Forms	69
Audio Visual Services	70
Electrical	73
Air and Water	75
Internet - Network / Telephone Services	77
Cable TV Order Form	81
Plant & Floral	83
Index	84

GES Information and Order Forms

All orders are governed by the GES Payment Policy and GES Terms & Conditions of Contract as specified in this Exhibitor Services Manual.

2013 Big O Tires Convention

Phoenix Convention Center
April 23, 2013

Official Service Provider

Global Experience Specialists, Inc. (GES)	Phone (in USA):	800.475.2098	International Calls:	702.515.5970
7000 Lindell Road	FAX (in USA):	866.329.1437	International Faxes:	702.263.1520
Las Vegas, NV 89118-4702	Contact us Online:	www.ges.com/chat		

GES will be onsite at your show to assist you in coordinating any last minute services, ordering additional products and answering any questions you may have.

Show Information

Booth Size: 10' X 10'
 Backwall Drapes: Black
 Sidewall Drapes: Black
 Table Skirt Color: Black
 Aisle Carpet Color: Red
 1 - 6' Skirted Table
 2 - Plastic Contour Chairs
 1 - Wastebasket
 1 - One line ID sign (7"x44") provided automatically

Important Dates *Be sure to check all order forms for additional deadlines*

Discount Deadline Date

Monday, April 1 GES orders must be received with payment by this date.

Installation

Monday, April 22 8:00 AM - 5:00 PM
 Tuesday, April 23 8:00 AM - 10:00 AM

Show Hours

Tuesday, April 23 12:00 PM - 8:00 PM

Dismantle

Wednesday, April 24 8:00 AM - 3:00 PM

Empty Container Return

Wednesday, April 24 8:00 AM Start time for Empty Container Return.

Carrier Check-in Post-Show

Wednesday, April 24 12:00 PM Carriers post-show must be checked-in by this time.

Facility Clear

Wednesday, April 24 3:00 PM All exhibitor materials must be removed.

Shipping Addresses *Use Provided Shipping Labels in this Exhibitor Services Manual to Expedite Handling*

Consign all **domestic** shipments c/o GES. Please do **not** consign **international** shipments c/o GES. Contact our international division at: GESLogistic_international@ges.com.

Advance Shipments to Warehouse:

c/o GES
 2013 Big O Tires Convention
 (Your Company Name & Booth Number)
 1740 South 40th Avenue
 Phoenix, AZ 85009
 USA

Shipments should arrive on or between:

March 20 - April 17, 2013
 Hours for receiving are Monday - Friday, 8:00 AM - 4:30 PM

Direct Shipments to Exhibit Site:

c/o GES
 2013 Big O Tires Convention
 (Your Company Name & Booth Number)
 Phoenix Convention Center
 100 North Third Street
 Phoenix, AZ 85004-2277
 USA

Shipments should arrive on:

April 22, 2013, 8:00 AM - 5:00 PM
 April 23, 2013, 8:00 AM - 10:00 AM

R060512 B011613-1106

Need Assistance?

Toll Free: 800.475.2098 | Tel: 702.515.5970 | www.ges.com/chat



Order Directly Online:
<https://e.ges.com/017600137/esm>

017600137

All orders are governed by the GES Payment Policy and GES Terms & Conditions of Contract as specified in this Exhibitor Services Manual.

2013 Big O Tires Convention

Phoenix Convention Center
April 23, 2013

We have designed this form to help you better understand the role of the Official Service Provider, the services we offer and to provide tips to maximize your cost savings.

What is an Official Service Provider?

GES has been selected as the Official Service Provider by the show organizer to design and produce your show. Because of the many areas that GES is involved in at the show, we are familiar with the key individuals managing your event. If at any time during the planning process you are unsure where to turn, just ask us – we're at your service.

Many Exhibitors are not aware of the depth and breadth of products and services offered by GES. Because we have insight into and control of the entire show process, we can generally save you time and money by assisting in your pre-show planning.

GES Show Services

Booth Furniture and Accessories

The booth furniture & accessories brochure showcases a wide variety of both standard and specialty furniture. All items rented from GES will automatically be delivered to your booth and picked up at the close of the show, with no material handling charges incurred by you.

Booth Carpet

GES offers a wide variety of carpet selections. The booth carpet brochure covers carpet choices from standard to custom color, size, grade, padding and booth cleaning. All carpet packages are available with no hidden costs or handling charges.

Custom Exhibits

Let GES design and build an extraordinary custom exhibit that will deliver your marketing message. Please visit our design gallery at www.ges.com.

Rental Exhibits

Our hassle-free rental program gives you a customized look without the long-term commitment of purchasing an exhibit. Please visit our design gallery at www.ges.com.

Installation and Dismantle Services

If you already own an exhibit, or plan to purchase one, you will need to arrange for installation and dismantling of your booth. As the Official Service Provider on this show, GES provides you with the best labor and on-site personnel from move-in to move-out.

Graphics

Give visitors to your exhibit a great first impression by displaying captivating graphics and signs.

Shipping

GES can manage your transportation without a hassle. We offer simplified rates, online tracking, and single invoicing. Call to have your "shipping made easy."

Lighting and Rigging

A great way to maximize your visibility on the show floor is by creating mood and movement in your booth through lighting.

Work Zone

Customer acknowledges that the show site and surrounding areas are active work zones. Customer, its agents, employees and representatives are present at their own risk.

How Can I Order My Show Services?

Expresso is GES' new planning, ordering and management system. You can order everything you need for your tradeshow exhibits, view account order history, download the show schedule and so much more.

Step 1: Go to <https://e.ges.com/017600137/esm>

Step 2: Find your show by typing the show name into the search box and selecting it.

Step 3: Browse products and services and make your selections. When you add the first item or service to your cart, you will be prompted to sign in or create an account if you have not ordered on Expresso before.

Step 4: When you're ready to complete your order, click your shopping cart and submit the required information.

GES National Servicer®

The GES National Servicer® provides consistency and continuity of customer service for exhibitors at all GES shows, offering the following services:

- Single point of contact for all GES shows
- Coast to coast time zone coverage
- Personalized exhibitor service for all pre- and post-show orders

7050 Lindell Road
Las Vegas, NV 89118
Phone: 800.475.2098 / Fax: 866.329.1437
International Phone: 702.515.5970 / Fax: 702.263.1520
Online Chat: www.ges.com/chat

GES Servicer®

Once you are at the show, the GES Servicer® is onsite to place any last minute orders and provide show information.

Exhibitor Services

Our Exhibitor Services organization is the service team responsible for answering exhibitor questions, processing your orders and handling any special requests. They are the conduits between production, operations and your exhibiting needs. Regardless of your request, you can contact them for advice and information about the show – if they don't know the answer, they will find it!

Need Assistance?

Toll Free: 800.475.2098 | Tel: 702.515.5970 | www.ges.com/chat



All orders are governed by the GES Payment Policy and GES Terms & Conditions of Contract as specified in this Exhibitor Services Manual.

2013 Big O Tires Convention

Phoenix Convention Center

April 23, 2013

As your tradeshow partner, our goal is to provide you with hassle-free service so you can get on with your show. Even if you use an Exhibitor Appointed Contractor, you should have a basic working knowledge of the Exhibitor Services Manual contents and information.

By following the information below, you will enjoy a smooth trade show experience.

Ordering Trade Show Services

- Please include your complete customer information on each order form including address with zip code, phone and fax numbers, e-mail addresses, company, and contact name and most importantly, booth number. If you have multiple booth locations, please complete separate order forms for each location (booth, meeting room, etc.).
- Please ensure that the credit card information is complete and correct including the expiration date.
- When ordering carpet, draped tables or counters remember to select the colors you desire.
- Please make sure that the size of the carpet you order is appropriate for your booth space (e.g.; do not order a 10' x 20' carpet for a 10' X 10' booth).
- Keep the total square footage of your booth space in mind when you order your decorating items. Don't order more than will comfortably fit in your booth and still allow you to do business.

Inbound - Move In

- Confirm your furnishings orders with the GES National Servicer[®] www.ges.com/chat. You should receive a confirmation of your order within 3-5 days of placement.
- **Confirm target dates with GES and communicate them to your carrier. Refer to the Special Handling brochure to ensure that you do not incur special handling charges. You may want to share this brochure with your carrier.**
- Keep the phone number of your carrier with you, including weekend contact and tracking numbers.
- Have your hotel information available, including phone number, address etc.
- After emptying crates, place empty labels on all sides of your crates and cases. Remember to remove old empty labels. Additionally, empty labels are sometimes color coded, so make sure you get the correct color and be sure your booth number is on each label.

Showsite

Put together a trade show survival kit to include in your freight or carry with you, including:

- Small Tool Kit
- Stapler, Scissors, Tape
- Pens & Markers for labels
- First Aid Kit
- Bottled Water

Work Zone

- Customer acknowledges that the show site and surrounding areas are active work zones. Customer, its agents, employees and representatives are present at their own risk.

Outbound - Move Out

- Keep in mind, the return of empty containers varies depending on the size of the show, so coordinate your outbound flight to accommodate this. GES does not provide security at show site. It is the Customer's responsibility to stay with their property. GES is not responsible for loss or damage to property left in the Customer's booth at any time for any reason.

Need Assistance?

Toll Free: 800.475.2098 | Tel: 702.515.5970 | www.ges.com/chat



Order Directly Online:
<https://e.ges.com/017600137/esm>

017600137

All orders are governed by the GES Payment Policy and GES Terms & Conditions of Contract as specified in this Exhibitor Services Manual.

2013 Big O Tires Convention

Phoenix Convention Center

April 23, 2013

Safety is very important for everyone working in the exhibit hall.

Global Experience Specialists, Inc. (GES) values safety throughout our organization and demonstrates it in the work we perform. By following the safety guidelines below you will be doing your part in creating a safe work environment.

Safety Guidelines:

- Only authorized personnel and employees allowed, all others are prohibited.
- This is an active work zone.
- All exhibitors and attendees enter at their own risk. Do not enter the dock/yard areas.
- Stay clear of heavy machinery.
- Never stand on furniture.
- Wear closed toe shoes.
- Clean up or report spills.
- Keep aisles free and clear of any and all debris.
- Practice good housekeeping.
- Check electrical cords for damage.
- Protect valuables at show site.
- Report any fires immediately.

If you notice anything unsafe please contact a GES employee immediately.

During move in and move out individuals under the age of 18 are prohibited from being on or around the show floor. Show sites during these times are similar to a construction zone and considered to be hazardous. OSHA regulations prohibit minors from being present in a hazardous work environment.

**STOP. THINK. SAFETY.**

All orders are governed by the GES Payment Policy and GES Terms & Conditions of Contract as specified in this Exhibitor Services Manual.

2013 Big O Tires Convention

Phoenix Convention Center

April 23, 2013

Union Information

To assist you in planning your participation in your Phoenix area show, we are certain you will appreciate knowing in advance that union labor will be required for certain aspects of your exhibit handling.

Jurisdiction Information

GES has a friendly, skilled, quality conscious and productive labor force in Phoenix. GES Phoenix is in partnership with the International Alliance of Theatrical and Stage Employees (IATSE). Members of this union claim jurisdiction over all set up and dismantling of exhibits, furniture installation, pipe and drape, hanging of signs and laying of floor coverings. In addition to utilizing the service of the Official Contractor, exhibitors may use full-time company personnel to assist in certain aspects of display erection. The services of outside display houses can be utilized as long as they comply with notification, safety and insurance provisions.

Arizona is a "right to work" state. However, union labor is required for certain aspects of your exhibit handling; the following is a description of the work rules and an outline of jurisdiction.

Material Handling

The unloading and delivery of all display related materials, machinery and equipment from the convention site docks to the exhibitor's booths and loading out from the exhibitor's booths to trucks at the docks must be performed by the Official Service Contractor. Exhibitors may "hand carry" items into the convention site, provided they do not use material handling equipment to assist them (e.g. dollies, luggage carts, hand trucks).

All booth and aisle cleaning is the jurisdiction of the Official Service Contractor.

Facility

Facility may provide some or all of the following services: electrical, plumbing, compressed air, sign hanging, cleaning of certain areas and phones. Their work rules and union jurisdictional issues would apply for these services. Should you have any questions concerning the service jurisdiction of any of the facilities please call GES at 800.475.2098.

Gratuities

Our work rules prohibit the SOLICITATION OR ACCEPTANCE of tips in cash, product or gifts in kind by any employee (union or non-union). Our employees are paid appropriate wages denoting professional status, therefore tipping of any kind is not allowed.

Work Zone

Customer acknowledges that the show site and surrounding areas are active work zones. Customer, its agents, employees and representatives are present at their own risk.

Always Honest Hotline

GES requires the highest standards of integrity from all employees. Please call our confidential Always Honest hotline at 866.225.8230 to report fraudulent or unethical behavior.



All orders are governed by the GES Payment Policy and GES Terms & Conditions of Contract as specified in this Exhibitor Services Manual.

2013 Big O Tires Convention
 Phoenix Convention Center
 April 23, 2013

GES Terms & Conditions are subject to change at GES' sole discretion without notice to any parties.

I. Definitions

GES: Global Experience Specialists, Inc., is hereinafter referred to as GES and/or GES Logistics, and/or Trade Show Electrical (a/k/a TSE) and/or Trade Show Rigging (a/k/a TSR) and their employees; **Agents:** GES' agents, sub-contractors, carriers, and the agents of each; **Customer:** Exhibitor or other party requesting Services from GES; **Goods:** Exhibits, property, and commodities of any type for which GES is requested to perform Services; **Carrier:** Motor carrier, van line, air carrier, or air or surface freight forwarder; **Shipper:** Party who tenders Goods to Carrier for transportation; **Cold Storage:** Holding of Goods in a climate controlled area; **Accessible Storage:** Holding of Goods in an area from which Goods may be removed during shows; **Services:** Warehousing, transportation, drayage, un-supervised labor, supervised labor and/or related services; **Show Site:** The venue or place where an exposition or event takes place; **Supervised Labor (OK TO PROCEED):** Union labor that is provided to a Customer to install or dismantle a booth or exhibit space, and is supervised and/or directed by GES; **Un-Supervised Labor (DO NOT PROCEED):** Union labor that is provided to a Customer to install or dismantle a booth or exhibit space and pursuant to Customer's election is not supervised and/or directed by GES. Customer assumes the responsibility and any liability arising therefrom, for the work of union labor when Customer elects to use un-supervised labor.

II. Scope

These Terms and Conditions shall be binding upon Customer, GES, and their respective Agents and representatives, including but not limited to Customer contracted labor such as Customer Appointed Contractors and Installation and Dismantle Companies, and any other party with an interest in the Goods. Each shall have the benefit of and be bound by all provisions stated herein, including but not limited to time limits and limitations of liability.

III. Customer Obligations

a. **Payment for services.** Customer shall be liable for all unpaid charges for services performed by GES or Agents. Customer authorizes GES to charge its credit card directly for services rendered on Customer's behalf after departure, by placing an order on-line, via fax, phone or through a work order on site.
 b. **Credit Terms.** All charges are due before Services are performed unless other arrangements have been made in advance. GES has the right to require prepayment or guarantee of the charges at the time of request for Services. A failure to pay timely will result in Customer having to pay in cash in advance for future services. GES retains its right to hold Customer Goods for non-payment. If a credit card is provided to GES, GES is authorized to bill to such credit card any unpaid charges for services provided to Customer, including charges for return shipping. Any charges not paid within 30 days of delivery will be subject to interest at 1 1/2% per month until paid.

IV. Mutual Obligation Indemnification

a. **Customer to GES:** Customer shall defend, hold harmless and indemnify GES from and against any claims, lawsuits, demands, liability, costs and expenses, including reasonable attorney's fees and court costs, resulting from any injury to or death of persons, or damage to property other than Goods, relating to or arising from performance of Services herein. Customer agrees to indemnify and hold GES harmless for any and all acts of its representatives and agents, including but not limited to Customer Appointed Contractors and Installation and Dismantle Companies, any subcontractor or other user of its space or any agents or employees engaged in business on behalf of Customer or present at Customer's invitation, including supervision of labor secured through GES. Customer's obligations under this provision shall not apply to GES' own negligence and/or willful misconduct. **CUSTOMER ACKNOWLEDGES THAT THE SHOW SITE IS AN ACTIVE WORK ZONE AND CUSTOMER, ITS AGENTS, EMPLOYEES AND REPRESENTATIVES ARE PRESENT AT THEIR OWN RISK.**

b. **GES to Customer:** To the extent of GES' own negligence and/or willful misconduct, and subject to the limitations of liability below, GES shall defend, hold harmless and indemnify Customer from and against any claims, lawsuits, demands, liability, costs and expenses, including reasonable attorney's fees and court costs, resulting from any injury to or death of persons, or damage to property other than Goods. GES' obligations under this provision shall not apply to claims for bodily injury arising a) from Customer's presence in areas which have been marked as "off limits to exhibitors"; and b) when exhibitors are present in the facility prior or subsequent to the effective dates or hours of Exhibitor's space lease with show management.

V. DISCLAIMER AND LIMITATION OF LIABILITY

UNDER NO CIRCUMSTANCES WILL ANY PARTY BE LIABLE FOR SPECIAL, INCIDENTAL, CONSEQUENTIAL INDIRECT OR PUNITIVE DAMAGES, INCLUDING BUT NOT LIMITED TO LOSS OF PROFITS OR INCOME. GES SHALL BE LIABLE, SUBJECT TO THE LIMITATIONS CONTAINED HEREIN, FOR LOSS OR DAMAGE TO GOODS ONLY IF SUCH LOSS OR DAMAGE IS CAUSED BY THE DIRECT NEGLIGENCE OR WILLFUL MISCONDUCT OF GES. CLAIMS PRESENTED FOR LOSS OR DAMAGE ARISING OUT OF INCIDENTS REFERENCED IN SECTION VI HEREIN WILL BE DENIED.

VI. No Liability for Loss or Damage to Goods

a. **Condition of Goods:** GES shall not be liable for damage, loss, or delay to uncrated freight, freight improperly packed, glass breakage or concealed damage. GES shall not be liable for ordinary wear and tear in handling of Goods or for damage to shrink wrapped Goods. All Goods shall be able to withstand handling by heavy equipment, including but not limited to forklifts, cranes, or dollies. It is the Customer's responsibility to ensure that Goods are packaged correctly prior to shipment or movement on or off the Show floor.
 b. **Receipt of Goods:** GES shall not be liable for Goods received without receipts, freight bills, or specified piece count on receipts or freight bills, or for bulk shipments (i.e., UPS, air freight, or van lines). Such Goods shall be delivered to booth without the guarantee of piece count or condition.
 c. **Force Majeure:** GES shall not be liable for loss or damage that results from Acts of God, weather conditions, act or default of Customer, shipper, or the owner of the Goods, inherent nature of the Goods, public enemy, public authority, labor disputes, and acts of terrorism or war.
 d. **Cold Storage:** Goods requiring cold storage are stored at Customer's own risk. GES assumes no liability or responsibility for Cold Storage.
 e. **Accessible Storage:** GES assumes no liability for loss or damage to Goods while in Accessible Storage. Storage charges are for the use of space and are not a form of insurance, or a guarantee of security.
 f. **Unattended Goods:** GES assumes no liability for loss or damage to unattended Goods received at Show Site at any time from the point of receipt of inbound Goods until the loading of the outbound Goods, including the entire term of the respective show or exhibition. Customer is responsible for insuring its own Goods for any and all risk of loss.
 g. **Empty Storage:** GES assumes no liability for loss or damage to Goods or crates, or the contents therein, while containers are in Empty Storage. It is Customer's sole responsibility to affix the appropriate labels available at the GES Service Desk for empty container storage, and ensures that any pre-existing empty labels are removed.
 h. **Forced Freight:** GES is not liable for Customer Goods left on the show floor after the show closing deadline, with or without a Material Handling Services/Straight Bill of Lading signed by Customer. It is Customer's responsibility to complete accurate paperwork for shipping and to

ensure Customer Goods are properly labeled. If Customer Goods remain on the floor after the show closing deadline, GES has the right to remove the Customer Goods. GES is authorized by Customer to proceed in the manner chosen by Customer on the Order of Material Handling Services/Straight Bill of Lading, if one has been completed, or otherwise to ship Customer Goods at the discretion of GES and at Customer's expense. GES shall incur no liability for such shipment. GES retains the right to dispose of Customer Goods without liability if left on the show floor unattended, without labels or not correctly labeled.

i. **Concealed Damage:** GES shall not be liable for concealed loss or damage including but not limited to: glass, electronic equipment, prototypes, original art, uncrated Goods, or improperly packaged or labeled Goods.
 j. **Unattended Booth:** GES shall not be liable for any loss or damage occurring while the Goods are unattended in Customer's booth at any time, including, but not limited to, the time the Goods are delivered to the dock until the time the Goods are received by Customer's chosen carrier. All Material Handling Forms and/or Straight Bills of Lading covering outgoing Goods submitted to GES will be checked at the time of pickup from the booth and corrections to the count or condition will be documented where discrepancies exist.
 k. **Hanging items from Booth:** Customer shall not hang any articles, merchandise, product, advertisements, or other similar items from GES supplied booth materials (this includes but is not limited to GES panels or pipe and drape), utilized in Customer's own booth set up or in areas occupied by the show organizer or third parties. If Customer does hang any prohibited items, Customer alone shall be held liable for any damages, costs, actions or injuries resulting from the hanging of such item(s). GES shall have no liability for any damages, costs, actions or injuries arising out of Customer's failure to comply with this provision.

VII. Measure of Damage

a. **Sole Relief:** If found liable for any loss, GES' sole and exclusive maximum liability for loss or damage to Customer's Goods is limited to \$.50 (USD) per pound with a maximum liability of \$100.00 (USD) per container, or \$1,500.00 (USD) per shipment whichever is less.
 b. **Labor:** GES assumes no liability for loss, damage, or bodily injury arising out of Customer's supervision of GES provided union labor. If GES supervises labor for a fee, GES shall be liable only for actions or claims arising out of its negligent supervision. Such liability shall be limited to the cost to Customer of the supervised labor or the depreciated value of the Goods, whichever is less. If Customer elects to use unsupervised labor, then Customer assumes all liability for the actions or claims that arise out of such work, including but not limited to loss, damage or bodily injury and shall provide GES and show management with an indemnity, including defense costs, for any claims that result from Customers' supervision or failure to supervise assigned labor.

VIII. Miscellaneous

a. **Insurance. GES IS NOT AN INSURANCE COMPANY AND DOES NOT OFFER OR PROVIDE INSURANCE.** It is the obligation of Customer to ensure Goods are insured at all times. Loss or theft of the Goods in storage or in transit to and from the show and or while on the show floor is the sole responsibility of Customer. GES recommends Customer arrange for all Risk Coverage.
 b. **Notice of Loss or Damage:** In order to have a valid claim, notice of loss or damage to Goods must be given to GES or its agent within 24 hours of occurrence (as evidenced in an Incident Report completed at Show Site by GES) or delivery of outbound Goods.
 c. **Filing of Claim:** Any claim for loss or damage to Goods must be in writing, containing facts sufficient to identify the Goods, asserting liability for alleged loss or damage, and making claim for the payment of a specified or determinable amount of money. Such claim must be filed with the appropriate party within the time limits specified herein. Damage reports, incident reports, inspection reports, notations of shortage or damage on freight bills or other documents, do not constitute filing of a claim. Claims for Goods alleged to be lost, stolen or damaged at the Show Site must be received in writing by GES within **thirty (30) days** after the close of the show. Claims for Goods alleged to be lost or damaged **during transit** must be received by the responsible party within nine (9) months of date of delivery of Goods. GES Logistics subcontracts the movement of Goods to third party carriers. Claims for damage in transit should be made directly with your carrier as shown on the Material Handling form/ Bill of Lading. In the event of a dispute with GES, Customer will not withhold payment or any amount due GES for Services as an offset against the amount of the alleged loss or damage. Customer agrees to pay GES prior to the close of the show for all such charges and further agrees that any claim Customer may have against GES shall be pursued independently by Customer as a separate action to be resolved on its own merits. GES retains the right to pursue collection on amounts owed after show close, without regard to any amount alleged to be owed for damage, or loss.
 d. **Filing of Suit:** Any action at law regarding loss or damage to Goods must be filed within one (1) year of the date of declaration of any part of a claim (logistics claims excluded).

IX. Jurisdiction, Choice of Forum

These Terms and Conditions of Contract shall be governed by and construed in accordance with the applicable laws of the United States or, alternatively, and depending on jurisdiction, the laws of the State of Nevada. The parties hereby submit to jurisdiction and venue in the United States Federal District Court of Nevada, or as applicable depending upon jurisdiction, the County Circuit Court in Clark County, Nevada.

X. Advanced Warehousing/Temporary Storage/Long Term Storage

All terms and conditions relative to Advanced Warehousing/Temporary Storage/Long Term Storage are contained in separate agreements titled "Storage Agreement". In the event that a Storage Agreement is not executed between the parties, the following shall apply with respect to GES' liability for Customer Goods. The responsibility of GES with respect to Customer Goods is limited to the exercise of ordinary care and diligence in handling and storing of Customer Goods. GES shall be liable only for loss or damage to Goods caused by GES' sole negligence. GES' liability is limited to \$.60 (USD) per pound with a maximum liability of \$100.00 (USD) per container, or \$1,500.00 (USD) per shipment whichever is less. In case of partial loss or damage, the maximum liability shall be prorated based on weight. GES is not responsible for any loss or damage to Goods caused by, but not limited to fire, theft, the elements, vandalism, moisture, vermin, mechanical breakdown or failure, freezing or changes in temperature, as well as any other causes beyond GES' immediate control. GES is not responsible for the marring, scratching or breakage of glass or other fragile items. GES is not liable for the mechanical functions of instruments or appliances even if such articles are packed or unpacked by GES. In no event shall GES be liable for special, incidental, indirect or consequential damages, including business loss of any kind, resulting from any damage to or loss of the Goods or from any act or failure to act. Customer pays storage fees or costs for advance warehousing for use of the space only. There is no guarantee of security or representations made by GES as to appropriateness of the conditions for Customer Goods. The risk of loss remains Customer's alone and GES recommends the Customer carry and maintain insurance in amounts sufficient to cover its risk.

Need Assistance?

Toll Free: 800.475.2098 | Tel: 702.515.5970 | www.ges.com/chat



All orders are governed by the GES Payment Policy and GES Terms & Conditions of Contract as specified in this Exhibitor Services Manual.

2013 Big O Tires Convention

Phoenix Convention Center

April 23, 2013

Dear Exhibitors: The Phoenix Fire Department wants to help you set up your exhibit in a safe manner. To avoid any last minute changes in your setup, we ask that you read the information below about the City's fire code as it pertains to your exhibit. Should questions arise after reviewing this material, or if your exhibit includes items that require special approval, please call Eric Williams, Fire Prevention Specialist, 602.495.5774 in advance of exhibit move-in.

General Requirements:

- A. The trade show/exhibit shall be set up as indicated on the approved plan(s).
- B. ALL DECORATIONS, including but not limited to, drapes, signs, banners, acoustical materials, cotton, hay, paper, straw moss split bamboo, wood chips, and foamcore shall be rendered flame retardant. Oilcloth, tar paper, nylon, plastic cloth and certain other plastic materials cannot be made flame retardant and their use is prohibited. Vertical carpet is not allowed unless it is flame retardant. Proof of a satisfactory flame retardant treatment may include a field flame test or documentation.
- C. Exit signs shall be visible from any location in the room. If not, temporary exit signs shall be posted.
- D. Exit and aisles shall be clear of all obstructions. This includes charts, easels, trailer tongues, etc.
- E. Aisles shall be a minimum ten (10) feet wide in the exhibit halls* and eight (8) feet wide in meeting rooms*. **This may be increased based upon the show type and setup.*
- F. A minimum three (3) foot clearance shall be provided around all fire extinguishers*, fire hose cabinets, and fire alarm pull stations. **If fire extinguishers are obstructed by booths or drapes then the event is responsible to provide accessible 2A-10BC fire extinguisher(s)*
- G. Combustible materials such as pamphlets or paper products shall be limited to a one (1) day supply and shall be maintained in an orderly fashion inside the booth. Any storage of combustible materials such as packing materials behind the booth is prohibited.
- H. Combustible materials (i.e., crates and boxes) shall be stored outside the building in an approved area or in an approved storeroom.
- I. Non-flammable compressed gas cylinders shall be properly secured to prevent tipping over.
- J. Single station smoke detectors shall be provided in all enclosed exhibits exceeding 120 square feet with roofs (i.e., recreational vehicles, mobile homes, tents, trailers, etc.). Enclosed exhibits exceeding 300 square feet shall comply with additional requirements.
- K. Booths which require 50' or more travel distance to reach an exit access aisle shall be provided with a minimum of two (2) exits remote from each other.

SPECIAL REQUIREMENTS:

- A. **LIQUID AND GAS FUELED VEHICLES AND EQUIPMENT:**
 - 1. All fuel tank fill caps shall be sealed in an approved manner to prevent the escape of vapors
 - 2. Fuel in the fuel tanks shall not exceed one quarter of the tank capacity or five (5) gallons (18.9L), whichever is less.
 - 3. Vehicles or equipment shall not be fueled or defueled within the building.
 - 4. The "hot lead" battery cable shall be removed from the battery used to start the vehicle while the vehicle is in the building. The disconnected battery cable shall be taped.
 - 5. Batteries used to power auxiliary equipment may be permitted to be kept in service.

- B. **COOKING AND WARMING DEVICES:** All cooking and warming shall be approved by the Fire Marshal. All cooking devices shall be listed by recognized testing laboratories (i.e., UL/FM).
 - 1. Cooking and warming devices shall be isolated from the public by either placing the devices minimum four (4) feet back from the front of the booth, or providing a rated Plexiglas shield between the public and the device(s).
 - 2. Individual cooking or warming devices shall not exceed 288 square inches of surface area.
 - 3. The table surface holding the cooking or warming device shall be of non-combustible material.
 - 4. A minimum of two (2) feet shall be provided between devices.
 - 5. Combustible materials shall be maintained a minimum of two (2) feet from cooking and warming devices.
 - 6. A 20-B:C rated fire extinguisher shall be provided, or an approved automatic extinguishing system shall be provided, within each booth utilizing cooking or warming devices.
 - 7. Butane burners are allowed providing that (1) the cylinder and appliance is listed (i.e. UL/FM), (2) the appliance shall not have more than (2) two non-refillable cylinders, each having a maximum capacity of 1.08 lbs (0.490 KG), (3) the full/empty cylinders shall be removed from the building after every day, and no extra cylinders shall be stored within the building.
- C. **ELECTRICAL:**
 - 1. Non-grounded two (2) wire extension cords are not permitted.
 - 2. Extension cords shall not be run under carpet/rugs unless designed to, or is approved by the in-house electricians.
 - 3. There shall be a three (3) foot clearance between lights and combustibles.
 - 4. All electrical cords, devices, and equipment shall be free from defects.
 - 5. All electrical cords in the path of travel shall be taped down to prevent tripping.
- D. **HAZARDOUS MATERIALS ARE PROHIBITED.** These include but are not limited to:
 - 1. Flammable compressed gases such as acetylene, hydrogen, and propane.
 - 2. Flammable liquids such as gasoline, kerosene, cleaning solvents, thinners and other petroleum-based liquids unless allowed in section A. LIQUID AND GAS FUELED VEHICLES.
 - 3. Hazardous materials such as pool chemicals, pesticides, corrosives, herbicides, poisons, etc.
 - 4. Explosive materials unless approved by the Fire Marshal.
 - 5. Cryogenic (i.e. liquid nitrogen, liquid oxygen, etc.) unless approved by the Fire Marshal.
- E. **OPEN FLAME DEVICES ARE PROHIBITED.** Exceptions include:
 - 1. Cooking or warming devices in compliance with B. COOKING AND WARMING DEVICES.
 - 2. Items reviewed and approved by the Fire Marshal (i.e. candles).
 - 3. Sterno may be used for warming trays.
- F. **SPECIAL PERMITS:**
 - 1. Tents over 400 square feet and canopies over 1200 square feet.
 - 2. Outdoor/indoor pyrotechnic events. Only a pyrotechnic operator with a valid City of Phoenix Certificate of Fitness Card is authorized to conduct a permitted display or show.

071712

Need Assistance?

Toll Free: 800.475.2098 | Tel: 702.515.5970 | www.ges.com/chat



All orders are governed by the GES Payment Policy and GES Terms & Conditions of Contract as specified in this Exhibitor Services Manual.

2013 Big O Tires Convention
 Phoenix Convention Center
 April 23, 2013

ATTENTION ALL EXHIBITORS!

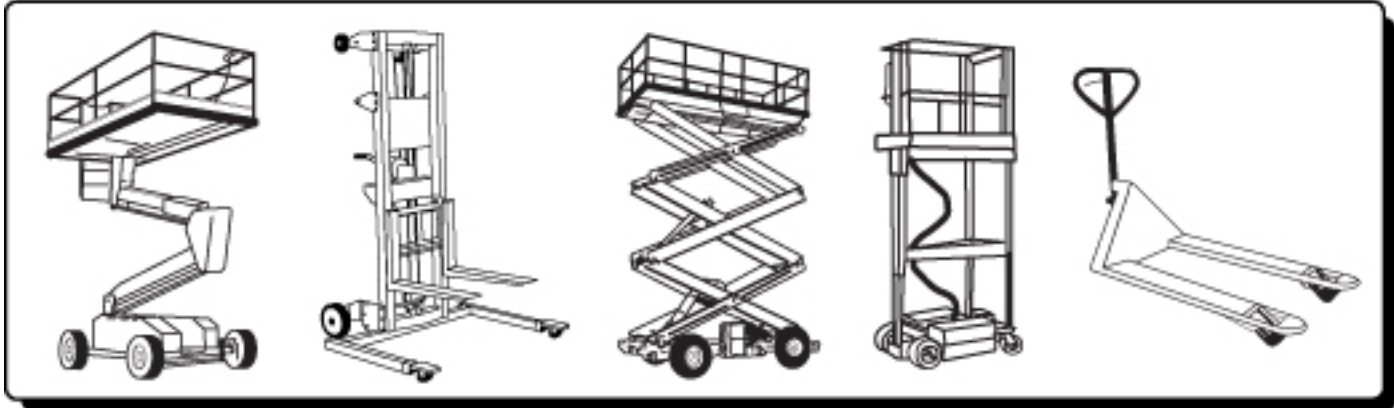

The operation or use of all motorized lifting equipment for installation of booth structures or signs is not permitted by exhibitors or their appointed contractors.

The operation or use of motorized or mechanical material handling equipment is not permitted by exhibitors or their appointed contractors. This also includes all mechanical scooters and carts.

ALL LIFTS, SCOOTERS, PALLET JACKS, DOLLIES AND MANPOWER MUST BE PROVIDED BY THE OFFICIAL SERVICE PROVIDER.

Scooters and carts may only be used by the individuals to whom the scooters and carts are issued. GES equipment is for use by GES employees only. Please **do not** take it for your use.

Customer acknowledges that the show site and surrounding areas are active work zones. Customer, its agents, employees and representatives are present at their own risk.

Thank you for your complete cooperation.

2013 Big O Tires Convention

Phoenix Convention Center

April 23, 2013

ATTENTION:

PETROLEUM SURCHARGE INFORMATION

Increased petroleum costs have impacted every facet of our business, from the cost of carpeting, plastics, visqueens, graphic substrates, propane & diesel fuel.

While the cost of gasoline has fluctuated greatly in recent months, the costs for other petroleum based products still are at record levels. GES has enacted a petroleum surcharge to partially recover the increased costs related to petroleum.

The Petroleum Surcharge will result in a 3% increase on all services published in the exhibitor services manual with the exception of GES Logistics, which already has a fuel surcharge built into the rates. These charges will be shown as a separate line item on your GES invoice.

GES thanks you for your continued support and patience during this critical time.

All orders are governed by the GES Payment Policy and GES Terms & Conditions of Contract as specified in this Exhibitor Services Manual.

2013 Big O Tires Convention

Phoenix Convention Center

April 23, 2013

Official Service Provider

Show Organizer, acting on behalf of all Exhibitors and in the best interest of the exposition, has appointed Official Service Providers to perform and provide necessary services and equipment. Official Service Providers are appointed to:

- Ensure the orderly and efficient installation and removal of the overall exposition,
- Assure the distribution of labor to all Exhibitors according to need,
- Provide sufficient labor to satisfy the requirements of Exhibitors and for the exposition itself,
- See that the proper type and limits of insurance are in force, and
- Avoid any conflict with local union and/or exhibit hall regulations and requirements.

The Official Service Providers will provide all usual trade show services, including labor. Exceptions are:

- a. Supervision may be provided by the Exhibitor.
- b. The Exhibitor may appoint an exhibit installation contractor or display builder.

In both such instances, GES shall have no liability to any party for damage or injuries caused by Exhibitor or its third party agents. Exhibitor is responsible for the actions of its third party contractors.

Exhibitor Appointed Contractors

Exhibitors may employ the service of independent contractors to install and dismantle their display, providing the Exhibitor and the installation and dismantling contractor comply with the following requirements:

1. The Exhibitor must notify Show Management in writing and Global Experience Specialists, Inc. (GES) of the intention to use an independent contractor no later than 30 days prior to the first move-in day furnishing the name, address and telephone number of the firm.
2. The Exhibitor shall provide evidence that the Exhibitor Appointed Contractor has proper insurance by submitting a certificate of insurance prepared by the "Exhibitor Appointed Contractor's" insurance agent with a minimum of coverage and limits as described below.
 - a. Commercial General Liability with limits of not less than \$1,000,000 each occurrence, \$2,000,000 general aggregate and \$2,000,000 products & completed operations aggregate.
 - b. Umbrella/Excess Liability with a limit of not less than \$1,000,000 each occurrence.
 - c. Workers Compensation, as required by law, with Employers Liability Limits of not less than \$1,000,000 each accident, \$1,000,000 disease - each employee and \$1,000,000 disease - policy limit.
 - d. Automobile Liability with a limit of not less than \$1,000,000 combined single limit - each accident.
 - e. The Commercial General Liability Policy shall name Global Experience Specialists, Inc. (GES) (Official Service Provider), Big O Tire Franchisee Convention (Show Management), 2013 Big O Tires Convention (Show) and Phoenix Convention Center (Facility) as additional insureds on a primary and non-contributory basis. See attached sample certificate of insurance.
3. Any Exhibitor who has identified an Exhibitor Appointed Contractor must ensure that the Exhibitor Appointed Contractor has a current Certificate of Insurance on file with GES or Show Management evidencing the correct coverage at least 10 days prior to the first move-in date for the show or the Exhibitor Appointed Contractor will not be able to have access to the facility to perform any work.
4. Customer acknowledges that the show site and surrounding areas are active work zones. Customer, its agents, employees and representatives are present at their own risk.

For your safety, be aware of the following:

- a. Do not enter dock areas in search of empty crates. Entry into these areas is at your sole risk.
 - b. During tear down, pull all manageable structures back from aisle carpet lines. Electronics, mannequins, etc. should be placed in the center of the booth.
 - c. Be aware of vehicle traffic inside and outside of the facility. All attendees are solely responsible for their own safety in parking lots, driveways, access roads and non-exhibit hall areas.
5. For services such as electrical, plumbing, telephone, cleaning and drayage, no service provider other than the Official Service Provider will be approved. This regulation is necessary due to licensing, insurance and work done on equipment and facilities owned by parties other than the Exhibitor. Exhibitors shall provide only the material and equipment they own and is to be used in their exhibit space.
 6. Exhibitor Appointed Contractor compliances:
 - a. Must agree to abide by all rules and regulations of the show as outlined in this exhibitor kit including all union rules and regulations.
 - b. Must have all business licenses, permits and Workers Compensation Insurance required by the State and City governments and the convention facility management prior to commencing work. A certificate of insurance complying with all requirements in paragraph 2 above must be submitted to GES at least 10 days prior to the first date of move in.
 - c. Will be responsible for all reasonable costs related to its operation including, but not limited to, overtime pay for stewards and restoration of exhibit space to its initial condition.
 - d. Must furnish Show Management and Global Experience Specialists, Inc. (GES) with the names of all on-site employees who will be working on the exposition floor and see that they have and wear at all times necessary identification badges as determined by Show Management.
 - e. Shall be prepared to show evidence that it has a valid authorization from the Exhibitor for services. The Exhibitor Appointed Contractor may not solicit business on the exhibit floor.
 - f. Must confine its operations to the exhibit area of its clients. No service desks, storage areas or other work facilities will be located anywhere in the building. The show aisles and public space are not a part of the Exhibitor's booth space and must be kept clear. Exhibitors may be charged for costs related to movement of its property if the Exhibitor Appointed Contractor does not contain its operations within the confines of the booth.
 - g. Shall provide, if requested, evidence to Global Experience Specialists, Inc. (GES) that it possesses applicable and current labor contracts and must comply with all labor agreements and practices. The Exhibitor Appointed Contractor must not commit or allow to be committed by persons in its employment any acts that could lead to work stoppages, strikes or labor problems.
 - h. Must coordinate all of its activities with Global Experience Specialists, Inc. (GES).
 - i. Must comply with all reasonable rules and regulations of the venue, Show Management and/or Official Service Provider in order to create a safe work environment. A failure to do so can result in a delay or termination of your right to continue if the condition cannot be corrected.
 - j. May not move freight from one booth to another booth, or to meeting rooms. GES must provide labor.
 7. All information must be received in the Global Experience Specialists, Inc. (GES) office no later than 10 days prior to the show.

Need Assistance?

Toll Free: 800.475.2098 | Tel: 702.515.5970 | www.ges.com/chat



ACORD		CERTIFICATE OF LIABILITY INSURANCE			DATE (MM/DD/YY) 01/01/13	
1. PRODUCER ABC Insurance Agency Fax: (212) 555-6100 1234 Broker Lane New York, NY 10895 Attn: Joe Agent (212) 555-6102 ext. 1234		THIS CERTIFICATE IS ISSUED AS A MATTER OF INFORMATION ONLY AND CONFERS NO RIGHTS UPON THE CERTIFICATE HOLDER, THIS CERTIFICATE DOES NOT AMEND, EXTEND OR ALTER THE COVERAGE AFFORDED BY THE POLICIES BELOW. INSUREERS AFFORDING COVERAGE				
2. INSURED Big Boom Company, Inc. 1234 Corporate Lane New York, NY 10895 Attn: Joe Smith Phone: (212) 555-5349 Fax: (212) 555-9819		INSURER A: Hartford Insurance Company of Illinois INSURER B: Aetna Casualty & Surety Company INSURER C: Travelers Insurance Company INSURER D: Royal Insurance Company INSURER E:				
COVERAGES						
THE POLICIES OF INSURANCE LISTED BELOW HAVE BEEN ISSUED TO THE INSURED NAMED ABOVE FOR THE POLICY PERIOD INDICATED. NOTWITHSTANDING ANY REQUIREMENT, TERM OF CONDITION OF ANY CONTRACT OR OTHER DOCUMENT WITH RESPECT TO WHICH THIS CERTIFICATE MAY BE ISSUED OR MAY PERTAIN, THE INSURANCE AFFORDED BY THE POLICIES DESCRIBED HEREIN IS SUBJECT TO ALL THE TERMS, EXCLUSIONS AND CONDITIONS OF SUCH POLICIES. LIMITS SHOWN MAY HAVE BEEN REDUCED BY PAID CLAIMS.						
INSR LTR	TYPE OF INSURANCE	POLICY NUMBER	POLICY EFFECTIVE DATE (MM/DD/YY)	POLICY EXPIRATION DATE (MM/DD/YY)	LIMITS	
A	GENERAL LIABILITY <input checked="" type="checkbox"/> COMMERCIAL GENERAL LIABILITY <input type="checkbox"/> CLAIMS MADE <input checked="" type="checkbox"/> OCCUR <input type="checkbox"/> _____ <input type="checkbox"/> _____ GENERAL AGGREGATE LIMIT APPLIES PER <input type="checkbox"/> POLICY <input type="checkbox"/> PROJECT <input type="checkbox"/> LOC	000P98298-A11	01/01/13	01/01/14	EACH OCCURENCE	\$1,000,000
	FIRE DAMAGE (Any one fire)				\$ 50,000	
	MED EXP (Any one person)				\$ 5,000	
	PERSONAL & ADV INJURY				\$1,000,000	
	GENERAL AGGRREGATE				\$2,000,000	
	PRODUCTS-COMP/OP AGG				\$2,000,000	
B	AUTOMOBILE LIABILITY <input checked="" type="checkbox"/> ANY AUTO <input type="checkbox"/> ALL OWNED AUTOS <input type="checkbox"/> SCHEDULED AUTOS <input checked="" type="checkbox"/> HIRED AUTOS <input checked="" type="checkbox"/> NON-OWNED AUTOS <input type="checkbox"/> _____ <input type="checkbox"/> _____	SKLS-029499S	01/01/13	01/01/14	COMBINED SINGLE LIMIT	\$1,000,000
	(Ea accident)					
	BODILY INJURY				\$	
	(Per person)					
	BODILY INJURY				\$	
	(Per accident)					
	PROPERTY DAMAGE				\$	
(Per accident)						
A	GARAGE LIABILITY <input type="checkbox"/> ANY AUTO <input type="checkbox"/> _____	XL1234567	01/01/13	01/01/14	AUTO ONLY-EA ACCIDENT	\$1,000,000
	OTHER THAN AUTO ONLY:				\$	
					\$	
					\$	
A	UMBRELLA/EXCESS LIABILITY <input checked="" type="checkbox"/> OCCUR <input type="checkbox"/> CLAIMS MADE <input type="checkbox"/> DEDUCTIBLE <input type="checkbox"/> RETENTION \$	A4145-SS-PJ37	01/01/13	01/01/14	EACH OCCURENCE	\$1,000,000
	AGGREGATE				\$1,000,000	
					\$	
					\$	
					\$	
C	WORKERS COMPENSATION AND EMPLOYERS' LIABILITY	A4145-SS-PJ37	01/01/13	01/01/14	X WC STATU-ORY LIMITS	OTHER
	E.L. EACH ACCIDENT				\$1,000,000	
	E.L. DISEASE-EA EMPLOYEE				\$1,000,000	
	E.L. DISEASE -POLICY LIMIT				\$1,000,000	
D	OTHER Professional Liability	000P98298-A11	01/01/13	01/01/14	Each Occurrence & Aggregate	\$1,000,000 \$3,000,000
5. DESCRIPTION OF OPERATIONS/LOCATIONS/VEHICLES/EXCLUSIONS ADDED BY ENDORSEMENT/SPECIAL PROVISIONS Global Experience Specialists, Inc. (GES) (Official Service Provider), Big O Tire Franchisee Convention (Show Management), Phoenix Convention Center (Facility), and 2013 Big O Tires Convention (Show) are hereby named as additional insureds, except for Workers' Compensation. Global Experience Specialists, Inc. (GES) and/or the consignor are included as Loss Payee. The insurance provided for the benefit of Global Experience Specialists, Inc. (GES), shall be primary insurance as respects any claim, loss, or liability, arising out of the Named Insured's operations for which the Named Insured is liable. Any other insurance maintained by GES shall be excess and non-contributory. Show date(s) are: April 23, 2013 at city of Phoenix.						
6. CERTIFICATE HOLDER		X	ADDITIONAL INSURED; INSURER LETTER: X		CANCELLATION	
Global Experience Specialists, Inc. (GES) Exhibitor Services 1740 S. 40th Avenue Phoenix, AZ 85009			SHOULD ANY OF THE ABOVE DESCRIBED POLICIES BE CANCELLED BEFORE THE EXPIRATION DATE THEREOF, THE ISSUING COMPANY WILL ENDEAVOR TO MAIL 30 DAYS WRITTEN NOTICE TO THE CERTIFICATE HOLDER NAMED TO THE LEFT, BUT FAILURE TO DO SO SHALL IMPOSE NO OBLIGATION OR LIABILITY OF ANY KIND UPON THE INSURER, ITS AGENTS OF REPRESENTATIONS AUTHORIZED REPRESENTATIVE John Smith, CIC			

- PRODUCER: Insurance Agent / Broker who issues certificate.
- NAME OF INSURED: Must be the legal name of contracting party.
- TYPES OF INSURANCE: Must include types required by contract. See Official Services Provider Information (form L-3) in this exhibitor manual).
- FORM OF COVERAGE: Must be "occurrence" form of coverage.
- NAME ADDITIONAL INSUREDS: Global Experience Specialists, Inc. (GES) (Official Service Provider), Big O Tire Franchisee Convention (Show Management), 2013 Big O Tires Convention (Show) and Phoenix Convention Center (Facility) as additional insureds on a primary and non-contributory basis.
- CERTIFICATE HOLDER: Must be Global Experience Specialists, Inc. (GES)
- POLICY EFFECTIVE DATE: Must be prior to or coincidental with the first day of Exhibitor Move-In.
- POLICY EXPIRATION DATE: Must be on or after the last day of Exhibitor Move-Out.
- LIMITS OF INSURANCE: Must be the same or greater than required by contract. See Official Services Provider Information (form L-3) in this exhibitor manual.
- NOTICE OF CANCELLATION: 30 days notice must be provided.
- AUTHORIZED REPRESENTATIVE: Must be signed (not stamped) by an authorized representative of Producer.

RETURN TO: Global Experience Specialists, Inc. (GES) • 7000 Lindell Road, Las Vegas, NV 89118-4702 • Fax: 866.329.1437 or 702.263.1520 for international exhibitors
 Contact us Online: www.ges.com/chat Phone: 800.475.2098 or 702.515.5970 for international exhibitors

All orders are governed by the GES Payment Policy and GES Terms & Conditions of Contract as specified in this Exhibitor Services Manual.

2013 Big O Tires Convention

Phoenix Convention Center
 April 23, 2013

Form Deadline Date:
 March 23, 2013

COMPANY NAME	EMAIL ADDRESS	BOOTH NUMBER
--------------	---------------	--------------

An Exhibitor Appointed Contractor is a company other than the "general or official" service provider on the show, or third party service provider designated by the show organizer in the exhibitor manual as the provider of a specific service and requires access to your booth during installation and dismantling. The Exhibitor Appointed Contractor may only provide services in the venue, which are not designated by the venue as "exclusive" to a venue provider, or by the show organizer in a contract as an exclusive service for the "official" or "general" service provider or other third party. If an Exhibitor Appointed Contractor attempts to provide services designated to another party as "exclusive" or is discovered soliciting on the show floor or otherwise does not comply with the rules, the company may be removed from the show floor, and the Exhibitor will not be able to use that company for the remainder of the event.

Due to the necessity of coordinating all activities during the move-in and for security purposes, Exhibitors who choose to use these contractors must complete this form, comply with all rules and regulations (listed below) and supply GES with all necessary information by the deadline date indicated above.

Exhibitor Appointed Contractor _____			
Street Address _____			
City, State, Zip _____			
Phone (_____) _____	Fax (_____) _____	On-Site Phone (_____) _____	
Contact: _____		E-mail Address: _____	
Description of Proposed Service for Exhibitor: _____			

This form will only be accepted if filled out by an authorized representative of the exhibiting company. Below are the Rules and Regulations regarding Exhibitor Appointed Contractors. Everyone must abide by these rules, which are accepted industry rules that were drafted by the International Association for Expositions & Events.

Rules & Regulations

- All Exhibitor Appointed Contractors must comply with show rules and regulations, and accept appropriate liability for any negligent actions.
- The Exhibitor Appointed Contractor acknowledges that the show site and surrounding areas are active work zones and the Exhibitor Appointed Contractor, its agents, employees and representatives are present at their own risk.
- The Exhibitor Appointed Contractors shall be prepared to show evidence to the Official Service Provider that it possesses applicable and current contracts.
- The Exhibitor Appointed Contractors shall be prepared to show evidence it has authorization from the contractor.
- The Exhibitor agrees that he is ultimately responsible for all services in connection with his exhibit, including freight, drayage, rentals and labor.
- The Exhibitor Appointed Contractor shall provide certificates of insurance and must agree in writing no later than 10 days prior to show opening.
- The Exhibitor Appointed Contractor will be responsible for all reasonable costs related to its operation, including overtime pay for stewards, restoration of exhibit space to its initial condition, etc. Where applicable a one hour minimum labor charge will be charged at the appropriate steward rate of pay per day/per union to either the Exhibitor Appointed Contractor/ Exhibitor depending upon the billing arrangement set up with GES. (Based upon Exhibitor Appointed Contractor not number of booths)
- The Exhibitor Appointed Contractor will not be permitted on the exhibit floor during the show days unless provided a proper registration badge by the exhibiting company.
- The show aisles and public spaces are not part of the Exhibitor's booth. Therefore, the Exhibitor Appointed Contractor is required to confine all activities to the exhibit space of the Exhibitor who has given the valid order for services. Exhibitors may be charged for costs related to movement of its property if the Exhibitor Appointed Contractor does not contain its operations within the confines of the booth.
- Solicitation on the exhibit floor is prohibited. Any Exhibitor Appointed Contractor or Non-official contractor engaged in any solicitation on the exhibit floor including the distribution of official company literature will be removed from the exhibit floor, unless pre-approved in writing by Show Organizer or GES Management.

- During show hours Exhibitor Appointed Contractors only with exhibit badges will be permitted on the exhibit floor. No installation and dismantling crew members will be permitted on the exhibit floor during show hours without the proper Convention name badge supplied by the exhibiting company. These badges should be ordered through the complimentary allotment of registration forms sent to each exhibiting company.
- The Exhibitor Appointed Contractor shall indemnify and hold Show Management and Global Experience Specialists, Inc. (GES) harmless from and against any and all negligent acts or omissions of Exhibitor Appointed Contractor, its agents, employees and representatives.

For insurance and safety reasons, the Official Service Provider designated in this service manual must be used for services such as:

Electrical	Plumbing	Booth Cleaning	Decorator Labor
Telephone	Rigging	Millwright Work	Material Handling

No exceptions will be made

Tips to Exhibitor Appointed Contractors

- Order services required from GES and the Exhibit Hall in advance. Ordering labor or services onsite which contractors may not be prepared to provide immediately may delay the set-up of your booth or force your set-up into overtime.
- Take steps to protect your client's product in the booth by arranging for booth security and/or cages.
- Please stay out of adjacent booths during set-up. Exhibitor Appointed Contractors must stay within the confines of the booth.
- Label empty cartons and crates for storage as soon as they are ready. Holding back on "empties" only adds congestion to the aisles.
- Do not store empty cartons inside of empty crates. Cartons are returned from storage first so Exhibitors may begin packing their product.
- Keep "No Freight Aisles" clear at all times. If GES is required to rearrange any material situated in a clearly identified "No Freight Aisle," you or your client depending upon your billing arrangements with GES, will be charged a one hour minimum for forklift rental and labor.
- Turn in outbound freight bills to the service desk on a timely basis. Holding freight bills until late in the day or turning in large amounts of freight bills to the GES Servicenter at one time may delay outbound truck scheduling and subsequently force your loading out into overtime.

Need Assistance?

Toll Free: 800.475.2098 | Tel: 702.515.5970 | www.ges.com/chat



Order Directly Online:
<https://e.ges.com/017600137/esm>

017600137

All orders are governed by the GES Payment Policy and GES Terms & Conditions of Contract as specified in this Exhibitor Services Manual.

2013 Big O Tires Convention

Phoenix Convention Center

April 23, 2013

Material Handling is the unloading of your exhibit materials, delivery to your booth, handling of empty containers to and from storage, and removal of your materials from your booth for reloading onto your outbound carrier. This is not to be confused with the cost to transport your exhibit material to and from the event.

Benefits of Advance Shipping to the GES Warehouse

- Storage of materials for up to 33 days prior to your show.
- Delivery of Shipments to your booth by your published set-up time.
- Some convention centers and hotels do not have facilities for receiving or storing freight.
- Saves valuable set-up time.

How to Ship in Advance to the GES Warehouse

- Remove all old shipping and empty storage labels.
- Fill out and attach enclosed Advance Shipping labels.
- Complete the enclosed Material Handling Order Form.
- Remember to confirm receipt of your shipment prior to leaving for the show.
- All shipments must have a bill of lading or delivery slip showing the number of pieces, weight, and type of merchandise.
- Certified weight tickets must accompany all shipments.
- Take the time to ensure that your display and products are packed neatly and securely.
- Do not ship uncrated materials to warehouse.
- For a rate quote please call GES Logistics at 1.888.454.4437.

How to Ship to Exhibit Site

- Consign all **domestic** shipments c/o GES.
- Do **not** consign **international** shipments c/o GES; however, please contact our international division at: GESLogistic_international@ges.com.
- Remove all old shipping and empty storage labels.
- Fill out and attach enclosed Direct Shipping labels.
- Complete the enclosed Material Handling Information Sheet.
- All shipments must have a bill of lading or delivery slip showing the number of pieces, weight, and type of merchandise.
- Certified weight tickets must accompany all shipments.
- Take the time to ensure that your display and products are packed neatly and securely.
- If you are shipping your carpet and/or lighting truss, make sure it is loaded last so it can be unloaded first.
- For a rate quote please call GES Logistics at 1.888.454.4437.

Freight Carriers

Select a carrier with experience in handling exhibition materials. Make sure to give your carrier explicit information as to where and when to check in. Delivery and pick up times are often out of the range of "normal" delivery hours, make sure your carrier is committed to meeting your target dates and times. While making shipping plans to the Show, also plan for the return shipment. For a rate quote please call GES Logistics at 1.888.454.4437.

Tracking Shipments

Confirm your delivery date and time with your carrier, and have all pertinent shipping information in the hands of your representative at show site. You may also want to review the return of your Goods at the end of the show. GES Logistics domestic shipments can be tracked online by going to: www.ges.com/everything/logistics/tracking/.

Estimating Material Handling Charges

Handling charges are based on the weight of the freight. Shipments are billed by the hundred weight and rounded up to the nearest hundred. Minimum per Shipment may apply, see enclosed Material Handling Order Form for details. Please prepay all shipping charges - GES cannot accept or be responsible for collect shipments. Crated and uncrated shipments must be separated and clearly identified on separate bills of lading with separate weight tickets - otherwise GES will invoice the entire load at the Uncrated rate.

- **Crated** – Material that is skidded, or is in any type of shipping container that can be unloaded at the dock with no additional handling required.
- **Uncrated** – Material that is shipped loose or pad-wrapped, and/or unskidded machinery without proper lifting bars or hooks.

Estimating Material Handling Charges, *continued*

- **Special Handling** - Defined as shipments that are loaded by cubic space and/or packed in such a manner as to require special handling, such as ground loading, side door loading, constricted space loading and designated piece loading or stacked shipments. Also included are mixed shipments and shipments without proper delivery receipts.
- **Overtime Surcharges** - Shows that move-in or move-out on weekends or after 4:30 PM during the weekday, may be subject to additional overtime surcharges. See enclosed Material Handling Order Form for details.
- **Late Surcharges** – May be charged an additional overtime surcharge
 - a. If advance freight is received before or after the published deadline date for shipments to arrive at the warehouse. See enclosed Material Handling Order Form for details.
 - b. Freight shipments sent to the show after it has opened.
 - c. Freight shipments that are received at showsite that do not meet their published date & time.
- **Shipment Surcharges** – A surcharge will be incurred per shipment for those that are received with incomplete information on shipping labels identifying company name and booth number and/or shipments that are left on the show floor at the end of the show with no labels and no bill of lading turned in.

Machinery Labor and Equipment

Labor and equipment for uncrating, unskidding, positioning, leveling, dismantling, recrating, and reskidding machinery and/or equipment must be ordered separately. Place your order for this labor using the In-Booth Forklift & Labor Order Form. If your material requires specialized rigging equipment, please notify us promptly so that we can make arrangements. When possible, supply your own rigging equipment with shipments and pre-rig your material.

Storing Empty Containers

Properly labeled empty shipping cartons will be picked up, stored, and returned after the show. Labels are available at the **GES Servicercenter**® or from your GES Service Executive and are for empty storage only. Depending on the size of the show, it can take from two to twelve hours to return empty crates. Do not store any items in crates marked "empty." GES has no liability for damage to crates or items sent to empty storage in crates.

Outgoing Shipments

An OMHF (Outbound Material Handling Form / Bill of Lading) must accompany all outgoing shipments. Shipping information, outbound forms and labels will be available at the **GES Servicercenter**®. Exhibitors selecting non-official carriers will need to make their own arrangements for pickup. Make sure that someone from your company will be on-site to oversee the outbound shipment of your display and product.

Measure of Damage

- **Liability** – GES is liable for loss or damage to your Goods only if the loss or damage is caused by GES negligence.
- **Sole Relief** – If found liable for any loss, GES' sole and exclusive maximum liability for loss or damage to Customer's Goods is limited to \$.50 (USD) per pound with a maximum liability of \$100 (USD) per container, or \$1,500.00 (USD) per shipment, whichever is less.

Insurance

All of your Goods should be insured by your own insurance policy. Although we do our best to handle your Goods as our own, there are many variables in shipping and handling that can affect your exhibit and products. GES has published GES Terms & Conditions of Contract that are in this exhibitor service manual. Please read them carefully. It is recommended that your Goods be insured.

Work Zone

Customer acknowledges that the show site and surrounding areas are active work zones. Customer, its agents, employees and representatives are present at their own risk.

Need Assistance?

Toll Free: 800.475.2098 | Tel: 702.515.5970 | www.ges.com/chat





Get *GES Transportation Plus* and
Save 10%
On Material Handling

The banner features a teal background on the left with white text. On the right, there are two vertical panels: the top one shows a road with a truck icon, and the bottom one shows a sky with an airplane icon. A dashed white line connects the truck and the airplane, suggesting a shipping route.

With decades of tradeshow experience, GES Logistics understands your transportation needs. As the Official Services Provider for your show, we offer a variety of fully integrated services at competitive rates.

GES Transportation Plus provides:

- Online tracking 24/7
- On-site GES support team
- Consolidated invoice

Note: Round-trip shipping is required to qualify for Transportation Plus rates. Transportation Plus does not apply to shipments that are considered small package, local or shipments over 5000 lbs.

Get an instant quote today at logisticsquote.ges.com.

RETURN TO: Global Experience Specialists, Inc. (GES) • 7000 Lindell Road, Las Vegas, NV 89118-4702 • Fax: 866.329.1437 or 702.263.1520 for international exhibitors
 Contact us Online: www.ges.com/chat Phone: 800.475.2098 or 702.515.5970 for international exhibitors

All orders are governed by the GES Payment Policy and GES Terms & Conditions of Contract as specified in this Exhibitor Services Manual.

2013 Big O Tires Convention
 Phoenix Convention Center
 April 23, 2013

Form Deadline Date:
 April 1, 2013

Go to below link to view images and information:
<http://ges.com/ecomm/info/specialhandling.pdf>

COMPANY NAME	EMAIL ADDRESS	BOOTH NUMBER
--------------	---------------	--------------

Transportation Plus: Ship With GES Logistics To Receive A 10.00% Savings On Material Handling. To set up your savings with **Transportation Plus** for domestic shipments please call 888.454.4437, or complete the GES Logistics - Domestic Shipping Quote Form (R-8) included in this exhibitor services manual and fax it to 702.515.5972, or email us at GESLogistics@ges.com. For international shipments complete the GES Logistics - International Shipping Quote Form (R-20) in this exhibitor services manual and fax it to 866.329.1437 or 702.263.1520, or email us at GESlogistic_International@ges.com. Call 888.454.4437 for a quote for any shipments that are under 5000 lbs. **Transportation Plus does not apply to shipments that are considered Small Package, Local or shipments over 5000 lbs. Round Trip shipping is required to qualify for Transportation Plus rates.**

Price List **Important Information**

Advance Shipment to Warehouse (200 lbs. minimum per shipment)

Crated Materials		Special Handling Materials			
Standard Rates	Transportation Plus Saving Rates	Standard Rates	Transportation Plus Saving Rates		
ST/ST	\$ 91.00 cwt	\$ 81.90 cwt	ST/ST	\$ 118.30 cwt	\$ 106.47 cwt
ST/OT	\$ 118.50 cwt	\$ 106.65 cwt	ST/OT	\$ 154.05 cwt	\$ 138.65 cwt
OT/OT	\$ 145.50 cwt	\$ 130.95 cwt	OT/OT	\$ 189.15 cwt	\$ 170.24 cwt

Direct Shipment to Exhibit Site (200 lbs. minimum per shipment)

Crated Materials		Special Handling Materials			
Standard Rates	Transportation Plus Saving Rates	Standard Rates	Transportation Plus Saving Rates		
ST/ST	\$ 81.00 cwt	\$ 72.90 cwt	ST/ST	\$ 105.30 cwt	\$ 94.77 cwt
ST/OT	\$ 105.50 cwt	\$ 94.95 cwt	ST/OT	\$ 137.15 cwt	\$ 123.44 cwt
OT/OT	\$ 129.50 cwt	\$ 116.55 cwt	OT/OT	\$ 168.35 cwt	\$ 151.51 cwt

Uncrated Materials		
Standard Rates	Transportation Plus Saving Rates	
ST/ST	\$ 129.60 cwt	\$ 116.64 cwt
ST/OT	\$ 168.80 cwt	\$ 151.92 cwt
OT/OT	\$ 207.20 cwt	\$ 186.48 cwt

Advance Shipments to Warehouse: GES will receive uncrated carpet and pad at the warehouse. A special handling charge will apply on these shipments. **Price includes:** unloading crated freight (the warehouse cannot receive uncrated shipments); storing at warehouse for up to 33 days (any materials stored beyond 33 days will incur additional costs applied to your invoice); reloading onto trucks and delivery to the exhibit site; unloading freight and delivery to your booth; picking up, storing, and returning empty shipping containers; and reloading freight for return to your specified destination from exhibit site.

Direct Shipments to Exhibit Site: Price includes: unloading freight and delivery to your booth; picking up, storing, and returning empty shipping containers; and reloading freight for return to your specified destination from exhibit site. However, any materials shipped back to warehouse from exhibit site will incur additional costs applied to your invoice.

Small Packages: Cartons and envelopes received without documentation will be delivered without guarantee of piece count or condition. Maximum weight is 50 lbs. per shipment, per delivery. This includes UPS and Federal Express shipments. All shipments received via air carrier that do not fall under the small package category may be subject to special handling charges.

Measure of Damage: If found liable for any loss, GES' sole and exclusive maximum liability for loss or damage to Customer's Goods is limited to \$.50 (USD) per pound with a maximum liability of \$100 (USD) per container, or \$1,500.00 (USD) per shipment, whichever is less.

Arrival Dates and Surcharges for Shipments: A 30% (\$50.00 minimum) late arrival surcharge based on the above rates will apply to each shipment received not within the below deadlines.

Advance Dates:
Wed, Mar 20, 2013: Advance shipments may begin arriving at warehouse.
Wed, Apr 17, 2013: Last day for shipments to arrive at warehouse.
Direct Dates:
Mon, Apr 22, 2013: Direct shipments may begin arriving at exhibit site after 8:00 AM.
Tue, Apr 23, 2013: Last day for shipments to arrive at exhibit site by 10:00 AM.

How To Know What Rates To Use Based On Show Move-In/Move-Out:
Straight Time: Monday through Friday 8:00 AM to 4:30 PM. Trucks signing in after 2:00 PM may be charged at the overtime rate.
Overtime: All other times, Saturdays, Sundays, Holidays.
ST/ST: If freight will be handled on straight time into the show and out of the show.
ST/OT: If freight will be handled one way on straight time and one way on overtime, either into the show or out of the show.
OT/OT: If freight will be handled on overtime into the show and out of the show.
Certified Weight Tickets Are Required For All Shipments:
 Drivers with inbound shipments must check in at the GES warehouse or exhibit site by 2:00 PM to be guaranteed same day unloading. Warehouse receiving hours are Monday - Friday, 8:00 AM - 4:30 PM; Closed 12:00 PM - 1:00 PM & Holidays. In the event of weight discrepancies or shipments received without a certified weight certificate, a \$ 16.35 fee will be charged per shipment.

Please Indicate Below **Place Order Here**

Calculate Total CWT (Enter in increments of 100's only; round up to the next 100 mark if your weight is more than 8 lbs. over the previous 100 mark. **200** pound minimum per shipment.)
 _____ pounds ÷ 100 = _____ Total CWT

Shipment Will Be Sent To:
 Exhibit Site Warehouse

On Date: _____
 By Carrier: _____
 Total Number of Pieces: _____

We understand that your calculation is only an estimate. Invoicing will be done from the actual weight. Adjustments will be made accordingly.

Place Order Here
 (Please Complete R-8 or R-20 for Using GES Logistics)

SMALL PACKAGE DESCRIPTION	PRICE	X QUANTITY	= TOTAL PRICE
Small Package, 1st Carton	\$ 47.50	1	\$
Small Package, Each Additional Carton	\$ 23.75		\$

MATERIAL HANDLING DESCRIPTION	PRICE	X	CWT	= TOTAL PRICE
				\$
A. Total All Items Ordered				\$
B. Petroleum Surcharge Assessment: 3%		A x 3% = B		\$
C. Payment Enclosed		A + B = C		\$

I agree in placing this order that I have accepted GES Payment Policy and GES Terms & Conditions of Contract.

Authorized Signature - Please Sign: _____ X

AUTHORIZED NAME - PLEASE PRINT	DATE
--------------------------------	------

Need Assistance?

Toll Free: 800.475.2098 | Tel: 702.515.5970 | www.ges.com/chat

Order Directly Online:
<https://e.ges.com/017600137/esm>

USE THESE SHIPPING LABELS AS THEY WILL EXPEDITE HANDLING. Copies of these labels are acceptable if additional labels are needed.
See form H-1a: Hanging Sign Shipping Labels when shipping Hanging Signs.

R-5



FROM:



TO:

FULL EXHIBITING COMPANY NAME AT SHOW

2013 Big O Tires Convention

NAME OF EXHIBITION

0170600137

BOOTH NUMBER

C/O GES
1740 South 40th Avenue
Phoenix, AZ 85009
USA

SHIPMENT SHOULD ARRIVE ON OR BETWEEN:
Wednesday, March 20, 2013 - Wednesday, April 17, 2013

CERTIFIED WEIGHT TICKETS ARE REQUIRED FOR ALL SHIPMENTS. Drivers must check in by 2:00 PM to be guaranteed same day unloading. Warehouse receiving hours are Monday - Friday, 8:00 AM - 4:30 PM; Closed 12:00 PM - 1:00 PM & Holidays.

Carrier _____
Number _____ of _____ pieces



FROM:



TO:

FULL EXHIBITING COMPANY NAME AT SHOW

2013 Big O Tires Convention

NAME OF EXHIBITION

0170600137

BOOTH NUMBER

C/O GES
1740 South 40th Avenue
Phoenix, AZ 85009
USA

SHIPMENT SHOULD ARRIVE ON OR BETWEEN:
Wednesday, March 20, 2013 - Wednesday, April 17, 2013

CERTIFIED WEIGHT TICKETS ARE REQUIRED FOR ALL SHIPMENTS. Drivers must check in by 2:00 PM to be guaranteed same day unloading. Warehouse receiving hours are Monday - Friday, 8:00 AM - 4:30 PM; Closed 12:00 PM - 1:00 PM & Holidays.

Carrier _____
Number _____ of _____ pieces





FROM:



TO:

FULL EXHIBITING COMPANY NAME AT SHOW

2013 Big O Tires Convention

NAME OF EXHIBITION

0170600137

BOOTH NUMBER

C/O GES
Phoenix Convention Center
100 North Third Street
Phoenix, AZ 85004-2277
USA

SHIPMENT SHOULD ARRIVE ON OR BETWEEN:

Monday, April 22, 2013 after 8:00 AM - Tuesday, April 23, 2013 by 10:00 AM

CERTIFIED WEIGHT TICKETS ARE REQUIRED FOR ALL SHIPMENTS. Drivers must check in by 2:00 PM to be guaranteed same day unloading. In the event of weight discrepancies or shipments received without a certified weight certificate, a \$ 16.35 fee will be charged per shipment.

Carrier _____
Number _____ of _____ pieces



FROM:



TO:

FULL EXHIBITING COMPANY NAME AT SHOW

2013 Big O Tires Convention

NAME OF EXHIBITION

0170600137

BOOTH NUMBER

C/O GES
Phoenix Convention Center
100 North Third Street
Phoenix, AZ 85004-2277
USA

SHIPMENT SHOULD ARRIVE ON OR BETWEEN:

Monday, April 22, 2013 after 8:00 AM - Tuesday, April 23, 2013 by 10:00 AM

CERTIFIED WEIGHT TICKETS ARE REQUIRED FOR ALL SHIPMENTS. Drivers must check in by 2:00 PM to be guaranteed same day unloading. In the event of weight discrepancies or shipments received without a certified weight certificate, a \$ 16.35 fee will be charged per shipment.

Carrier _____
Number _____ of _____ pieces

RETURN TO: Global Experience Specialists, Inc. (GES) • 7000 Lindell Road, Las Vegas, NV 89118-4702 • Fax: 866.329.1437 or 702.263.1520 for international exhibitors
 Contact us Online: www.ges.com/chat Phone: 800.475.2098 or 702.515.5970 for international exhibitors

All orders are governed by the GES Payment Policy and GES Terms & Conditions of Contract as specified in this Exhibitor Services Manual.

2013 Big O Tires Convention
 Phoenix Convention Center
 April 23, 2013

Form Deadline Date:
 April 1, 2013

COMPANY NAME	EMAIL ADDRESS	BOOTH NUMBER
--------------	---------------	--------------

Complete this form for pre-printed outbound material handling documents (Bill of Lading) and shipping labels at the close of the show.

To take advantage of this service, please complete and return this form. If this form is not received by GES by the time of above Deadline Date, this pre-printing service will not be provided.

Step 1. Tell us the location of materials for pickup:

COMPANY/CONSIGNEE:		ATTENTION:			
STREET ADDRESS:		CITY:	STATE:	ZIP:	COUNTRY:
100 North Third Street		Phoenix	AZ	85004-2277	USA
PHONE:	FAX:			BOOTH NUMBER:	

Step 2. Tell us the location where freight should be sent:

SHIPPING DESTINATION 1:

Number of Labels Needed:

COMPANY/CONSIGNEE:		ATTENTION:			
STREET ADDRESS:		CITY:	STATE:	ZIP:	COUNTRY:
PHONE:	FAX:			BOOTH NUMBER:	

SHIPPING DESTINATION 2:

Number of Labels Needed:

COMPANY/CONSIGNEE:		ATTENTION:			
STREET ADDRESS:		CITY:	STATE:	ZIP:	COUNTRY:
PHONE:	FAX:			BOOTH NUMBER:	

Showsite Instructions: Once your shipment is packed and ready to be picked up, please return the outbound material handling order form to the **GES Servicercenter®**. Verify the piece count, weight, and that the signature is on the outbound material handling order form prior to shipping out. **Shipments without paperwork turned in will be returned to GES Warehouse or forced onto another carrier at Exhibitor's expense.**

GES does not accept responsibility for any exhibitor property left on the show floor unattended at any time for any reason.

Measure of Damage: If found liable for any loss, GES' sole and exclusive maximum liability for loss or damage to Customer's Goods is limited to \$.50 (USD) per pound with a maximum liability of \$100.00 (USD) per container, or \$1,500.00 (USD) per shipment, whichever is less.



RETURN TO: Global Experience Specialists, Inc. (GES) • 7000 Lindell Road, Las Vegas, NV 89118-4702 • Fax: 866.329.1437 or 702.263.1520 for international exhibitors
 Contact us Online: www.ges.com/chat Phone: 800.475.2098 or 702.515.5970 for international exhibitors

All orders are governed by the GES Payment Policy and GES Terms & Conditions of Contract as specified in this Exhibitor Services Manual.

2013 Big O Tires Convention

Phoenix Convention Center
 April 23, 2013

COMPANY NAME		EMAIL ADDRESS			BOOTH NUMBER:
SHOWSITE CONTACT		SHOWSITE CONTACT PHONE #		DATE/TIME OF ARRIVAL	CONTACT'S HOTEL (OPTIONAL)
Pick Up Information					
DATE:		SHIPPING / RECEIVING HOURS (4 HOUR WINDOW REQUIRED):			
STREET ADDRESS:		CITY:	STATE:	ZIP:	COUNTRY:
PICK UP CONTACT:		PHONE NUMBER:		FAX NUMBER:	
SHIPPING INSTRUCTIONS (ADDITIONAL CHARGES MAY APPLY):					MARK FOR WEEKEND PICK UP OR DELIVERY: <input type="checkbox"/> Pick Up <input type="checkbox"/> Delivery

Delivery Information					
DATE:		RECEIVING HOURS:			
DESTINATION:		EXHIBITOR NAME:			
SHOW NAME:		BOOTH NUMBER:			
STREET ADDRESS:		CITY:	STATE:	ZIP:	COUNTRY:
SHOW CONTRACTOR:		CONTACT:		PHONE NUMBER:	

Method of Shipment		
Ground: <input type="checkbox"/> Less than a Truck Load <input type="checkbox"/> Truck Load Rates (Price Per Shipment) Shipments 0-100 lbs.* Shipments 101 lbs. and up* _____ *Subject to Applicable Surcharges	Air: <input type="checkbox"/> Next Day <input type="checkbox"/> 2nd Day <input type="checkbox"/> Deferred * Dim weight or actual weight, whichever is greater, will apply to Next Day and 2nd Day.	Special Instructions (Additional Charges May Apply)

Weight & Dimensions (Final Weight Subject to Correct Weight & Dimensions)											
Mark "X" in the H/M column to designate hazardous materials as defined in Department of Transportation Regulations.											
LIST EACH PIECE	H/M	DIMENSIONS IN INCHES			EST. WEIGHT	LIST EACH PIECE	H/M	DIMENSIONS IN INCHES			EST. WEIGHT
		L x	W x	H				L x	W x	H	
		L x	W x	H				L x	W x	H	
		L x	W x	H				L x	W x	H	
		L x	W x	H				L x	W x	H	
		L x	W x	H				L x	W x	H	
		L x	W x	H				L x	W x	H	
		L x	W x	H				L x	W x	H	
		L x	W x	H				L x	W x	H	

Total Pieces:	Total Weight:	Hazardous Materials Contact Number () _____ - _____
You must read the Terms and Conditions of Contract under which GES provides transportation services to you, our valued customer. The Terms and Conditions may be downloaded by going to www.ges.com/terms/logistics.aspx . If you do not have internet capability, a copy of the Terms and Conditions may be obtained by contacting your GES Logistics representative at 1.888.454.4437.		I agree in placing this order that I have accepted GES Payment Policy and GES Terms & Conditions of Contract. Authorized Signature - Please Sign: X
I have read and agree to the Terms and Conditions of Contract and have the right and authority to bind the exhibiting company referenced herein to such terms.		AUTHORIZED NAME - PLEASE PRINT DATE

Measure of Damage: If found liable for any loss, GES' sole and exclusive maximum liability for loss or damage to Customer's Goods is limited to \$.50 (USD) per pound with a maximum liability of \$100.00 (USD) per container, or \$1,500.00 (USD) per shipment, whichever is less.

Subject to individually determined rates or contracts that have been agreed upon in writing between GES and shipper, if applicable, otherwise to the rates, classifications and rules that have been established by GES and are available to the shipper, on request; **By signing this order form, shipper agrees to be bound by all its terms and conditions.**

11/09/12

Get GES Global Transportation Plus and

Save 10%

On Material Handling



GES Logistics provides an integrated network of carriers that service transportation solutions to over 80 countries by land, air and sea. Documentation services include ATA Carnet and temporary import bonds for the most comprehensive worldwide support available.

GES Global Transportation Plus delivers these unique benefits:

- Save 10% on material handling when using GES Logistics round-trip shipping
- Consolidated invoicing for material handling and shipping charges
- Managed transportation to and from the show floor
- On-site customer support

Note: All international transportation services are subject to the terms, conditions, limits of liability and instructions as set forth by the carrier.

To request a quote call 702.515.5970 or contact us at logisticsquote.ges.com/international.

RETURN TO: Global Experience Specialists, Inc. (GES) • 7000 Lindell Road, Las Vegas, NV 89118-4702 • Fax: 866.329.1437 or 702.263.1520 for international exhibitors
 Contact us Online: www.ges.com/chat Phone: 800.475.2098 or 702.515.5970 for international exhibitors

All orders are governed by the GES Payment Policy and GES Terms & Conditions of Contract as specified in this Exhibitor Services Manual.

2013 Big O Tires Convention

Phoenix Convention Center
 April 23, 2013

COMPANY NAME	EMAIL ADDRESS	BOOTH NUMBER
Pick Up Information		
PICKUP DATE:	SHIPPING / RECEIVING HOURS:	
STREET ADDRESS:	CITY:	PROVINCE: POSTAL CODE: COUNTRY:
PICK UP CONTACT:	PHONE NUMBER:	FAX NUMBER:
SHIPPING INSTRUCTIONS (ADDITIONAL CHARGES MAY APPLY):		MARK FOR WEEKEND PICK UP OR DELIVERY: <input type="checkbox"/> Pick Up <input type="checkbox"/> Delivery

Please complete the following information by either checking the appropriate box or by filling in the blank. Please be as thorough as possible as this will enable us to provide you with the most accurate cost estimate possible.

Method of Shipment			
Type of Customs Entry:	<input type="checkbox"/> Permanent (Sold/Giveaways)	Value of Permanent Goods (US\$):	\$
	<input type="checkbox"/> Temporary (To Return)	Value of Temporary Goods (US\$):	\$
Mode of Transport:	<input type="checkbox"/> Ocean FCL	<input type="checkbox"/> Ocean LCL	<input type="checkbox"/> AirFreight <input type="checkbox"/> Truck
Type of Equipment for FCL:	<input type="checkbox"/> 40' Container	<input type="checkbox"/> 20' Container	<input type="checkbox"/> High Cube <input type="checkbox"/> Other:
Commodity:			
Desired Delivery Date or Targeted Move-In Date:			

Weight & Dimensions (Final Weight Subject to Actual Weight & Dimensions)					
Detailed Description of Contents (1)	Length (2) cms	Width (3) cms	Height (4) cms	Net Weight (5) kilos	Value (US\$) (6)
					\$
					\$
					\$
					\$
					\$
					\$
					\$
					\$
					\$
					\$
					\$
					\$
					\$
					\$

Use a separate piece of paper if you need to provide additional weight and dimensions.
 Check this box if you would like to receive a return quote back to origin specified at the top of this form.

I agree in placing this order that I have accepted GES Payment Policy and GES Terms & Conditions of Contract. Authorized Signature - Please Sign: _____ X	Total Gross Weight (7)	Total Value (8)
	kilos	\$
AUTHORIZED NAME - PLEASE PRINT	DATE	

You must read the Terms and Conditions of Contract under which GES provides transportation services to you, our valued customer. The Terms and Conditions may be downloaded by going to www.ges.com/terms/logistics.aspx. If you do not have internet capability, a copy of the Terms and Conditions may be obtained by contacting your GES Logistics representative at 1.888.454.4437.

SPECIAL REQUIREMENTS (ADDITIONAL CHARGES MAY APPLY)

GES is acting as a broker only and is liable for cargo loss or damage only if it results from the negligence or willful misconduct of GES. If found liable for any loss, GES' and the transportation provider's sole and exclusive maximum liability for loss or damage to Customer's Goods is limited to \$.50 (USD) per pound per package, \$ 100.00 (USD) per package or \$ 1,500.00 (USD) per occurrence, whichever is less.

All international transportation services are subject to the terms, conditions, and limits of liability set forth by the international transportation provider. If loss or damage occurs during transit, the liability of the underlying air carrier is governed by Montreal Protocol #4 to the Warsaw Convention.

Subject to individually determined rates or contracts that have been agreed upon in writing between GES and shipper, if applicable, otherwise to the rates, classifications and rules that have been established by GES or its transportation provider and are available to the shipper on request. **By signing this order form, shipper agrees to be bound by all its terms and conditions.**

103111

RETURN TO: Global Experience Specialists, Inc. (GES) • 7000 Lindell Road, Las Vegas, NV 89118-4702 • Fax: 866.329.1437 or 702.263.1520 for international exhibitors
 Contact us Online: www.ges.com/chat Phone: 800.475.2098 or 702.515.5970 for international exhibitors

All orders are governed by the GES Payment Policy and GES Terms & Conditions of Contract as specified in this Exhibitor Services Manual.

2013 Big O Tires Convention
 Phoenix Convention Center
 April 23, 2013

Discount Deadline Date:
 April 1, 2013

COMPANY NAME	EMAIL ADDRESS	BOOTH NUMBER
--------------	---------------	--------------

Important Information & Rates

A storage area will be available for Exhibitor's literature and samples not requiring refrigeration. The charge for storage as described will be per skid, one skid minimum. This charge includes one time delivery to storage area and delivery from storage to booth after the close of the show. Maximum size per single item is not to exceed 48" x 48" x 72". When ready for delivery of material to or from storage, please notify the **GES Servicerter**. Standard labor rates apply for each delivery to the booth, or return of material to storage. Access storage is **NOT SECURED** storage. All items are stored at Exhibitor's sole risk

Notice – You MUST have an authorized company representative present at the time of delivery to your booth to inventory the items and to sign for receipt of items. Delivery hours may be restricted, check with the representatives in the **GES Servicerter**.

The minimum charge for labor is one (1) hour per worker and equipment. Labor thereafter is charged in half (1/2) hour increments per worker and equipment. **Gratuities in any form, including cash, gifts, or labor hours for work not actually performed are prohibited by GES.** GES requires the highest standards of integrity from all employees. Please call our confidential Always Honest hotline at 866.225.8230 to report fraudulent or unethical behavior. All rates are subject to change if necessitated by increased labor and material costs.

LABOR RATES ARE AS FOLLOWS:

Forklift with Operator	Discount	Regular	Show Site
5,000#, ST Code: 705200	\$ 218.50	\$ 273.00	\$ 328.00
5,000#, OT Code: 705200	\$ 306.00	\$ 383.00	\$ 459.00
5,000#, DT Code: 705200	\$ 551.00	\$ 689.00	\$ 827.00

Worker per Hour	Discount	Regular	Show Site
Storage, ST Code: 705044	\$ 91.00	\$ 114.00	\$ 137.00
Storage, OT Code: 705044	\$ 137.00	\$ 171.00	\$ 206.00
Storage, DT Code: 705044	\$ 274.00	\$ 343.00	\$ 411.00

Straight Time: Monday through Friday from 8:00 AM to 4:30 PM.
Overtime: All other times Monday through Friday. All day Saturday & Sunday.
Double Time: All day Holidays.
Discount Rate: Rate applies to orders placed on or before the above Discount Deadline Date.
Regular Rate: Rate applies to orders placed after the above Discount Deadline Date, but before the first day of exhibitor move-in.
Show Site Rate: Rate applies to orders placed at show site

Place Order Here

SCHEDULE DATE(S)	SCHEDULE START TIME	SCHEDULE END TIME	TOTAL # OF HOURS	TOTAL # OF FORKLIFTS	LABOR RATE	TOTAL	3% PSP	GRAND TOTAL
	AM PM	AM PM						\$
	AM PM	AM PM						\$
	AM PM	AM PM						\$
	AM PM	AM PM						\$
								\$

Please estimate the number of workers and hours per worker needed for delivery and removal above. Invoice will be calculated according to actual hours worked, relative to the original estimate and based upon the date received. Additional labor required will be calculated and invoiced at the show site rate.

Labor Payment Enclosed \$

Please Indicate

Please describe your product:

ITEM#	DESCRIPTION	PRICE	QUANTITY	TOTAL PRICE
200513	Access Storage, Per Pallet/Piece	\$65.75		\$
A.	Total All items Ordered			\$
B.	Petroleum Surcharge Assessment: 3%		A x 3% = B	\$
C.	Payment Enclosed		A + B = C	\$

I agree in placing this order that I have accepted GES Payment Policy and GES Terms & Conditions of Contract.

Authorized Signature - Please Sign: X

AUTHORIZED NAME - PLEASE PRINT	DATE
--------------------------------	------



RETURN TO: Global Experience Specialists, Inc. (GES) • 7000 Lindell Road, Las Vegas, NV 89118-4702 • Fax: 866.329.1437 or 702.263.1520 for international exhibitors
 Contact us Online: www.ges.com/chat Phone: 800.475.2098 or 702.515.5970 for international exhibitors

All orders are governed by the GES Payment Policy and GES Terms & Conditions of Contract as specified in this Exhibitor Services Manual.

2013 Big O Tires Convention
 Phoenix Convention Center
 April 23, 2013

Form Deadline Date:
 April 1, 2013

COMPANY NAME	EMAIL ADDRESS	BOOTH NUMBER
--------------	---------------	--------------

Special Freight Services — Small Passenger Vehicles Only!

Maximum Weight 200 lbs

- To facilitate the move-in and move-out of Exhibitors with small exhibit material shipments, Global Experience Specialists, Inc. (GES) is pleased to make available for hire, one (1) laborer with one (1) pushcart, for one (1) trip. Services can be made **one way** from the dock to your booth or your booth to the dock. Charges for these services are \$37.00 each way.
- This service is for those who have **small hand carry items** all of which must fit on a 2' x 6' push cart, in one trip only. **If you arrive with a truck, van, trailer, or truck with trailer filled with exhibit material you will not qualify for this service and will be redirected.**
- A cartload is eight (8) pieces or less, weighing less than 200 lbs. total. There is one cartload allowed per booth.
- Your vehicle must unload on the receiving dock of the exhibit hall. GES personnel will direct vehicles. The cart is not authorized to enter or go to any parking structure. There must be two (2) people with the vehicle; one person to go with your product to the booth space and one person to remove your vehicle from the unloading area to the parking area.
- Freight that is too large or heavy will be charged Material Handling rates.** No personal trucks (one (1) ton & over), no rental trucks, trailers, or bobtails will be unloaded through cartload service.
- To receive this service, go to either the facility's main entrance or dock and ask about or watch for the Cartload Service area. Pre-orders will receive preferential service at show site, you may also order this service at the GES Servicenter.



Place Order Here				
ITEM#	DESCRIPTION	PRICE	QUANTITY	TOTAL PRICE
200506	Dock to Booth	\$37.00	1	\$
200506	Booth to Dock	\$37.00	1	\$
A.	Total All items Ordered			\$
B.	Petroleum Surcharge Assessment: 3%		A x 3% = B	\$
C.	Payment Enclosed		A + B = C	\$
I agree in placing this order that I have accepted GES Payment Policy and GES Terms & Conditions of Contract.				
Authorized Signature - Please Sign:			X	
			AUTHORIZED NAME - PLEASE PRINT	DATE



RETURN TO: Global Experience Specialists, Inc. (GES) • 7000 Lindell Road, Las Vegas, NV 89118-4702 • Fax: 866.329.1437 or 702.263.1520 for international exhibitors
 Contact us Online: www.ges.com/chat Phone: 800.475.2098 or 702.515.5970 for international exhibitors

All orders are governed by the GES Payment Policy and GES Terms & Conditions of Contract as specified in this Exhibitor Services Manual.

2013 Big O Tires Convention
 Phoenix Convention Center
 April 23, 2013

Form Deadline Date:
 April 1, 2013

COMPANY NAME _____ EMAIL ADDRESS _____ BOOTH NUMBER _____

Vehicle placement on the trade show floor will be a round-trip fee of \$197.00 per vehicle. It is understood that this will apply to rolling stock, self-propelled, towed and/or pushed vehicles/machinery. GES will receive equipment at show site and deliver to the Exhibitor booth. We will also handle the outbound as an inclusive service.

Vehicle placement must be Exhibitor Supervised. GES assumes no liability for loss, damage or bodily injury arising out of the placement of Exhibitor's vehicle. Exhibitor assumes the responsibility and any liability arising therefrom, for the work performed by union labor under Exhibitor's supervision. Exhibitor's must stay clear during movement of the vehicle.

Exhibitor will be at show site on _____, 20____, between _____ and _____ AM/PM to assist in the movement of the vehicle.

The City Fire Marshal requires that battery cables must be disconnected, place a protective covering under the vehicle, gas tank must either be taped shut or have a lockable gas cap and may contain no more than a quarter (1/4) tank of fuel. Exhibitor is responsible for checking local Fire Marshal rules and regulations for additional requirements.

Be advised that if you are planning to display a vehicle, you are required to provide the information listed on this page. A GES Representative will contact you regarding a specific time when to have your vehicle ready to go onto the tradeshow floor.

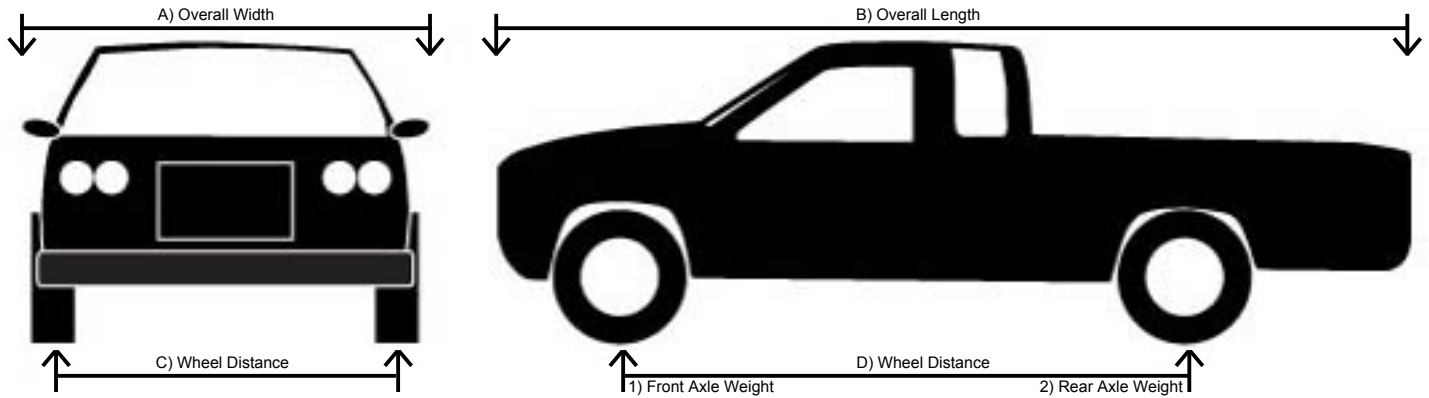

Vehicle Description	A) Overall Width	B) Overall Length	Total Sq. Ft.	C) Wheel Distance	D) Wheel Distance	1) Front Axle Weight	2) Rear Axle Weight	Total Weight	Total Price
1.									\$
2.									\$
3.									\$
4.									\$
5.									\$

* For dual Axle vehicles measure distance from the front wheel to between the back wheels

A.	Total All Items Ordered:	\$
B.	Petroleum Surcharge Assessment: 3% A x 3% = B	\$
C.	Item # 200507 Payment Enclosed A + B = C	\$
I agree in placing this order that I have accepted GES Payment Policy and GES Terms & Conditions of Contract.		
Authorized Signature - Please Sign: X		
AUTHORIZED NAME - PLEASE PRINT		DATE

GES® offers eco-friendly and conventional carpet to enhance the look and comfort of your exhibit. Available in various colors of three carpet grades with padding option:

Ultra Plush (50 oz.) 
 50 oz. carpet is 100% recyclable and offered as a business standard for our premium grades.

Plush (26 oz.) 
 26 oz. carpet is 100% recyclable and offered as a business standard for our premium grades.

Standard (13 oz.)
 13 oz. is conventional filament nylon carpet that is re-used for pre-cut sizes and new for custom-cut orders

Padding (1/2 in.) 
 Double-netted rebound pad is 100% recyclable, made with 98% pre & post consumer content.

100% recyclable flooring solutions have the same industry tradeshow performance standards as conventional carpet and help to reduce the volume of excess materials from entering landfills.

 The leaf symbol indicates recyclable or eco-friendly materials, per manufacturers specifications.

Ultra Plush

Includes:

- 50 oz. 100% recyclable premium carpet 
- 4 mil poly covering
- anti-static treatment
- 3M Scotchgard™ protection



Bisque (81)



Black (41)



Cabernet (82)

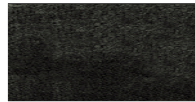

Graphite (83)

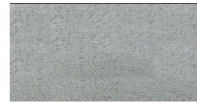

Iceberg (84)

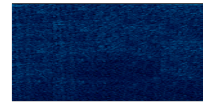

Midnight (85)

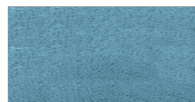

Seascape (86)



Sterling (87)



Teal (55)

Ultra Plush Color Codes

- Bisque (81)
- Cabernet (82)
- Iceberg (84)
- Seascape (86)
- Teal (55)
- Black (41)
- Graphite (83)
- Midnight (85)
- Sterling (87)

Our carpet is offered as pre-cut, custom-cut or in carpet packages that include visqueen and recycled padding. Visqueen and recycled padding are also available as upgrades.

Rental includes material handling, installation, front edge taping, and pick-up at the close of the show.

To order contact the GES National Servicer® at 800.475.2098 or fill out and fax the enclosed order form.

Plush

Includes:

- 26 oz. 100% recyclable premium carpet
- 4 mil poly covering
- anti-static treatment
- 3M Scotchgard™ protection

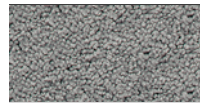

Cement (70)

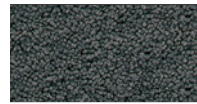

Charcoal (71)

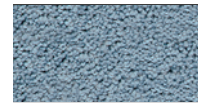

Cobalt (72)

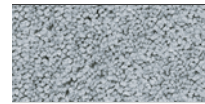

Dove (73)

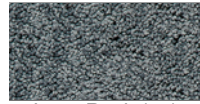

Lava Rock (74)

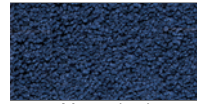

Navy (75)



Onyx (76)

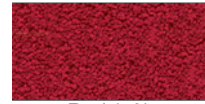

Red (49)

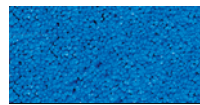

Royal Blue (77)



Silky Beige (78)

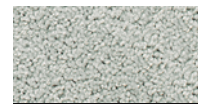

Silver (79)



Snow (80)

Standard

Includes:

- 13 oz. filament nylon carpet
- Available in pre-cut sizes (see order form for details)
- Custom-cut includes 4 mil poly covering



Black (41)



Blue (42)



Blue Jay (56)



Burgundy (43)

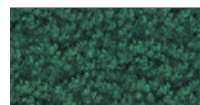

Emerald Green (44)

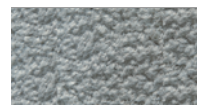

Gray (40)



Pepper (52)



Red (49)

Plush Color Codes

- | | | | |
|-------------------|--------------------|---------------|-------------|
| - Cement (70) | - Charcoal (71) | - Cobalt (72) | - Dove (73) |
| - Lava Rock (74) | - Navy (75) | - Onyx (76) | - Red (49) |
| - Royal Blue (77) | - Silky Beige (78) | - Silver (79) | - Snow (80) |

Standard Color Codes

- | | |
|----------------------|-----------------|
| - Black (41) | - Blue (42) |
| - Blue Jay (56) | - Burgundy (43) |
| - Emerald Green (44) | - Gray (40) |
| - Pepper (52) | - Red (49) |

RETURN WITH G-2: PAYMENT & CREDIT CARD CHARGE AUTHORIZATION FORM TO:

Global Experience Specialists, Inc. (GES) • 7000 Lindell Road, Las Vegas, NV 89118-4702 • Fax: 866.329.1437 or 702.263.1520 for international exhibitors

All orders are governed by the GES Payment Policy and GES Terms & Conditions of Contract as specified in this Exhibitor Services Manual.
2013 Big O Tires Convention

Phoenix Convention Center



April 23, 2013

Discount Deadline Date:

April 1, 2013

COMPANY NAME	EMAIL ADDRESS	BOOTH NUMBER
--------------	---------------	--------------

Price List

ITEM#	DESCRIPTION	DISCOUNT PRICE	REGULAR PRICE
Standard Pre-Cut Carpet			
<i>Custom-cut carpet is required for all booths larger than 300 square feet, or for booths configured as island or peninsula.</i>			
5001	13 oz. Standard Carpet 10'x10'	\$ 156.00	\$ 234.00
5002	13 oz. Standard Carpet 10'x20'	\$ 307.00	\$ 461.00
5003	13 oz. Standard Carpet 10'x30'	\$ 473.00	\$ 710.00
Visqueen Plastic Covering for Protection			
500410	Carpet Plastic Covering, Per Sq.Ft.	\$ 0.90	\$ 1.35
Padding 			
<i>GES Offers the finest padding used in the industry, a 1/2" double-netted rebond pad. We guarantee your satisfaction.</i>			
500400	Carpet Padding, 1/2" Thick, Per Sq.Ft.	\$ 1.81	\$ 2.72
 <i>The leaf symbol indicates recyclable or eco-friendly materials per manufacturer's specifications.</i>			
Cancellation Policy: Custom Size Booth Carpet cancelled after being cut will be charged 100%. All other carpet cancelled will be charged 50% of original price after move-in begins and 100% of original price after installation.			

ITEM#	DESCRIPTION	DISCOUNT PRICE	REGULAR PRICE
Custom-Cut Carpet			
<i>Guaranteed to be high quality carpet, and includes visqueen plastic covering. All custom orders must be received 14 days prior to move-in to guarantee delivery and color selection.</i>			
5000	13 oz. Carpet Custom-Cut, Per Sq.Ft.	\$ 2.91	\$ 4.37
5006	26 oz. Plush Carpet Custom-Cut, Per Sq.Ft.	\$ 4.13	\$ 6.20
5007	50 oz. Ultra Plush Carpet Custom-Cut, Per Sq.Ft.	\$ 5.50	\$ 8.25
 <i>26oz. Plush and 50 oz. Ultra Plush Carpets are 100% recyclable and offered as a business standard for our premium grades.</i>			
<i>Custom-Cut Carpet can be custom-dyed and we offer discounts for orders exceeding 2,000 square feet (please call for a quote). Custom dye orders require 30 days to process. A minimum of 100 square feet is required for custom-cut carpet orders.</i>			
<i>Prices include delivery, rental, and removal. Labor to install carpet is included when the carpet is installed on a flat floor space prior to exhibit installation. Labor will be charged at published rates when installation is required for stairs, platforms, risers, meeting rooms, or other installations post exhibit installation.</i>			

Please Indicate Choice

- 13 oz. Carpet Colors** (Item #'s 5001, 5002, 5003, 5000 ONLY).
 Gray will be provided if no color is indicated below:
- Black (41) Blue (42) Blue Jay (56)
 Burgundy (43) Emerald Green () Gray (40)
 Pepper (52) Red (49)
- 26 oz. Plush Custom-Cut Carpet Colors** (Item #'s 5006 ONLY).
 Dove will be provided if no color is indicated below:
- Cement (70) Charcoal (71) Cobalt (72)
 Dove (73) Lava Rock (74) Navy (75)
 Onyx (76) Red (49) Royal Blue (77)
 Silky Beige (78) Silver (79) Snow (80)
- 50 oz. Ultra Plush Custom-Cut Carpet Colors** (Item #'s 5007 ONLY).
 Iceberg will be provided if no color is indicated below:
- Bisque (81) Black (41) Cabernet (82)
 Graphite (83) Iceberg (84) Midnight (85)
 Seascape (86) Sterling (87) Teal (55)
 Black

Do you require electrical or utilities under the carpet?

- Yes No

Calculate Total Square Footage:

Width: _____ x Length: _____ = _____ Square Feet

Place Order Here

ITEM#	DESCRIPTION	PRICE	QUANTITY	TOTAL PRICE
5001	13 oz. Standard Carpet 10'x10'		1	\$
5002	13 oz. Standard Carpet 10'x20'		1	\$
5003	13 oz. Standard Carpet 10'x30'		1	\$

ITEM#	DESCRIPTION	TOTAL SQ FT	X PRICE / SQ FT =	TOTAL PRICE
				\$
				\$
				\$
				\$
				\$
				\$
				\$
				\$
				\$
				\$
				\$
				\$

A.	Total All Items Ordered		\$
B.	Petroleum Surcharge Assessment: 3%	A x 3% = B	\$
C.	Subtotal	A + B = C	\$
D.	Rental Tax: 9.3%	C x 9.3% = D	\$
E.	Payment Enclosed	C + D = E	\$

I agree in placing this order that I have accepted GES Payment Policy and GES Terms & Conditions of Contract.
Authorized Signature - Please Sign:

AUTHORIZED NAME - PLEASE PRINT	DATE
--------------------------------	------

Need Assistance?

Toll Free: 800.475.2098 | Tel: 702.515.5970 | www.ges.com/chat



Order Directly Online:

<https://e.ges.com/017600137/esm>

Chairs



300051 - Chair, Contemporary Arm, 23"W 18"D 31"H



300052 - Chair, Contemporary Side, 19.5"W 18"D 31"H



300050 - Chair, Plastic Contour, 18"W 18.5"D 32"H



300053 - Stool, Contemporary, 17"W 18"D 48"H

Tables



300057 - Table, Rectangle, 24"x36"x30" High



300056 - Table, Square, 24"x24"x30" High



300059 - Table, Starbase, 30" Diameter x 40" High



300058 - Table, Starbase, 40" Diameter x 30" High

Skirted Tables



3004 - Table 4', Skirted 4 Sides, 24" x 30" High



3006 - Table 6', Skirted 3 Sides, 24" x 30" High















3008 - Table 8', Skirted 3 Sides, 24" x 30" High



3007 - Table, Skirt 4th Side

Table Skirt Colors

- | | | | |
|---|--|---|---|
|  Beige (54) |  Black (41) |  Blue (42) |  Burgundy (43) |
|  Forest Green (45) |  Gold (46) |  Gray (40) |  Mauve (47) |
|  Purple (48) |  Red (49) |  Teal (55) |  White (50) |

Display Furniture



Full View



Half View



Quarter View



Vertical

Accessories



300124 - Aisle Stanchion, Chain, Plastic, Per Foot



300123 - Aisle Stanchion, without Chain



300103 - Aluminum Easel



300111 - Bag Stand



300102 - Coat Rack



300104 - Garment Rack



300106 - Literature Rack



300201 - Pegboard, White, 4'x8'



300107 - Refrigerator



300131 - Security Cage, Large, without Lock



300120 - Sign Holder, Bell Base



300108 - Sign Holder, Chrome, 22"x28"



300211 - Tackboard, 4'x8'



300112 - Ticket Tumbler, Small, Table Top



300118 - Waterfall Stand

RETURN WITH G-2: PAYMENT & CREDIT CARD CHARGE AUTHORIZATION FORM TO:

Global Experience Specialists, Inc. (GES) • 7000 Lindell Road, Las Vegas, NV 89118-4702 • Fax: 866.329.1437 or 702.263.1520 for international exhibitors

All orders are governed by the GES Payment Policy and GES Terms & Conditions of Contract as specified in this Exhibitor Services Manual.

2013 Big O Tires Convention

Phoenix Convention Center
April 23, 2013

Discount Deadline Date:

April 1, 2013

COMPANY NAME _____ EMAIL ADDRESS _____ BOOTH NUMBER _____

Price List

ITEM#	DESCRIPTION	DISCOUNT PRICE	REGULAR PRICE	ITEM#	DESCRIPTION	DISCOUNT PRICE	REGULAR PRICE
Chairs				Display Furniture			
300051	Chair, Contemporary Arm, 23"W 18"D 31"H	\$ 98.75	\$ 148.00	300079	Display Case 5', Half View	\$ 501.00	\$ 752.00
300052	Chair, Contemporary Side, 19.5"W 18"D 31"H	\$ 92.25	\$ 138.00	300080	Display Case 5', Quarter View	\$ 501.00	\$ 752.00
300050	Chair, Plastic Contour, 18"W 18.5"D 32"H	\$ 70.50	\$ 106.00	300082	Display Case 6', Full View	\$ 515.00	\$ 773.00
300053	Stool, Contemporary, 17"W 18"D 48"H	\$ 106.00	\$ 159.00	300083	Display Case 6', Half View	\$ 515.00	\$ 773.00
Tables				300084	Display Case 6', Quarter View	\$ 515.00	\$ 773.00
300057	Table, Rectangle, 24"x36"x30" High	\$ 92.25	\$ 138.00	300088	Display Case 7', Vertical	\$ 673.00	\$ 1,010.00
300056	Table, Square, 24"x24"x30" High	\$ 84.75	\$ 127.00	Accessories			
300059	Table, Starbase, 30" Diameter x 40" High	\$ 156.00	\$ 234.00	300124	Aisle Stanchion Chain, Plastic, Per Foot	\$ 4.26	\$ 6.40
300058	Table, Starbase, 40" Diameter x 30" High	\$ 156.00	\$ 234.00	300123	Aisle Stanchion, without Chain	\$ 41.50	\$ 62.25
Skirted Tables				300103	Aluminum Easel	\$ 56.25	\$ 84.50
<i>Skirting for Tables - White Vinyl Top and Pleated Skirt</i>				300111	Bag Stand	\$ 77.50	\$ 116.00
3004	Table 4', Skirted 4 Sides, 24" x 30" High	\$ 106.00	\$ 159.00	300102	Coat Rack	\$ 77.50	\$ 116.00
3006	Table 6', Skirted 3 Sides, 24" x 30" High	\$ 134.00	\$ 201.00	300104	Garment Rack	\$ 77.50	\$ 116.00
3008	Table 8', Skirted 3 Sides, 24" x 30" High	\$ 150.00	\$ 225.00	300106	Literature Rack	\$ 109.00	\$ 164.00
3007	Table, Skirt 4th Side	\$ 63.00	\$ 94.50	300201	Pegboard, White, 4'x8'	\$ 134.00	\$ 201.00
Skirted Counters				300107	Refrigerator	\$ 307.00	\$ 461.00
<i>Skirting for Counters - White Vinyl Top and Pleated Skirt</i>				300131	Security Cage, Large, without Lock	\$ 428.00	\$ 642.00
3014	Counter 4', Skirted 4 Sides, 24" x 42" High	\$ 121.00	\$ 182.00	300120	Sign Holder, Bell Base	\$ 70.50	\$ 106.00
3016	Counter 6', Skirted 3 Sides, 24" x 42" High	\$ 150.00	\$ 225.00	300108	Sign Holder, Chrome, 22"x28"	\$ 70.50	\$ 106.00
3018	Counter 8', Skirted 3 Sides, 24" x 42" High	\$ 170.00	\$ 255.00	300211	Tackboard, 4'x8'	\$ 141.00	\$ 212.00
3017	Counter, Skirt 4th Side	\$ 63.00	\$ 94.50	300112	Ticket Tumbler, Small, Table Top	\$ 121.00	\$ 182.00
Risers				300113	Wastebasket	\$ 17.40	\$ 26.00
300193	Riser 4', Double Tier, 48"x8"x16" High	\$ 48.50	\$ 72.75	300118	Waterfall Stand	\$ 77.50	\$ 116.00
300191	Riser 4', Single Tier, 48"x8"x8" High	\$ 34.50	\$ 51.75	<i>Prices include delivery, installation, rental, and removal.</i>			
300194	Riser 6', Double Tier, 72"x8"x16" High	\$ 63.00	\$ 94.50				
300192	Riser 6', Single Tier, 72"x8"x8" High	\$ 48.50	\$ 72.75				
Custom Booth Drape							
3001	Drape, 3' High, Per Foot, 4' Minimum	\$ 14.50	\$ 21.75				
3002	Drape, 8' High, Per Foot, 4' Minimum	\$ 17.40	\$ 26.00				
Display Furniture							
300073	Display Case 4', Corner View	\$ 501.00	\$ 752.00				
300074	Display Case 4', Full View	\$ 486.00	\$ 729.00				
300075	Display Case 4', Half View	\$ 486.00	\$ 729.00				
300076	Display Case 4', Quarter View	\$ 486.00	\$ 729.00				
300078	Display Case 5', Full View	\$ 501.00	\$ 752.00				

Please Indicate Choice

Drape / Skirt Color (3004, 3006, 3008, 3007, 3014, 3016, 3018, 3017, 3002 ONLY)

Gray will be provided if no color is indicated below:

- | | | |
|--|--|--------------------------------------|
| <input type="checkbox"/> Beige (54) | <input type="checkbox"/> Black (41) | <input type="checkbox"/> Blue (42) |
| <input type="checkbox"/> Burgundy (43) | <input type="checkbox"/> Forest Green (45) | <input type="checkbox"/> Gold (46) |
| <input type="checkbox"/> Gray (40) | <input type="checkbox"/> Mauve (47) | <input type="checkbox"/> Purple (48) |
| <input type="checkbox"/> Red (49) | <input type="checkbox"/> Teal (55) | <input type="checkbox"/> White (50) |

4th Side Table Skirt (3007 ONLY)

- 6' Table 8' Table

4th Side Counter Skirt (3017 ONLY)

- 6' Counter 8' Counter

Tackboard/Perfboard Alignment (300201 and 300211 ONLY)

- Horizontal Vertical

Please include Booth Layout form (H-3) for placement of items.

Orders received after the discount deadline date are subject to availability and/or substitutions.

Place Order Here

ITEM#	DESCRIPTION	PRICE	QUANTITY	TOTAL PRICE
				\$
				\$
A.	Total All Items Ordered			\$
B.	Petroleum Surcharge Assessment: 3%		A x 3% = B	\$
C.	Subtotal		A + B = C	\$
D.	Rental Tax: 9.3%		C x 9.3% = D	\$
E.	Payment Enclosed		C + D = E	\$
I agree in placing this order that I have accepted GES Payment Policy and GES Terms & Conditions of Contract.				
Authorized Signature - Please Sign: X				
AUTHORIZED NAME - PLEASE PRINT				DATE

Cancellation Policy: Items cancelled will be charged 50% of original price after move-in begins and 100% of original price after installation.

Need Assistance?

Toll Free: 800.475.2098 | Tel: 702.515.5970 | www.ges.com/chat



Order Directly Online:
<https://e.ges.com/017600137/esm>

Seating - Sofas and Loveseats



305066 - Loveseat, Black Leather, 64"L 36"D 34"H



305068 - Loveseat, Key West, Black, 57"L 35"D 33"H



305067 - Loveseat, Newport, Charcoal Leather, 54"L 34"D 33"H



305118 - Sectional, 3 pc., Newport, Charcoal, 113"L 34"D 33"H



305120 - Sectional, South Beach, 3 pc., Platinum, 152"L 40"D 33"H



305236 - Sofa, Allegro, Blue Fabric, 73"L 34.5"D 29.5"H



305117 - Sofa, Astro, 83"L 36"D 29"H



305125 - Sofa, Key West, Black, 85"L 35"D 33"H



305121 - Sofa, Lisbon, Black Leather, 88"L 36"D 34"H



305116 - Sofa, Marrakesh, Light Beige, 84"L 37"D 34"H



305124 - Sofa, Memphis, 55"L 31"D 28"H



305226 - Sofa, Mirabel, Brown Leather, 76"L 35"D 32"H



305221 - Sofa, Roma, White Vinyl, 78"L 31"D 33"H



305119 - Sofa, South Beach, Platinum Suede, 69"L 29"D 33"H

Colors may vary due to facility lighting, printing limitations and dye lot differences. Some items may not be available at all locations. See order form for details. Styles of items portrayed on this brochure may vary in some locations.

Seating - Club Chairs



305235 - Chair, Allegro, Blue Fabric, 36\"/>



305081 - Chair, Astro Light Beige, 36\"/>



305072 - Chair, Barcelona, Black, 30\"/>



305073 - Chair, Barcelona, White, 30\"/>



305074 - Chair, Cappuccino, 29\"/>



305180 - Chair, Globus, 28\"/>



305178 - Chair, Lisbon, Black Leather, 40\"/>



305080 - Chair, Marrakesh, Light Beige, 34\"/>



305127 - Chair, Memphis, 27.25\"/>



305225 - Chair, Mirabel, Brown Leather, 36\"/>



305179 - Chair, Newport, Charcoal Leather, 24\"/>



305220 - Chair, Roma, White Vinyl, 37\"/>



305070 - Chair, Tub, Key West, Black, 31\"/>



305035 - Corner, Charcoal Leather, 34\"/>

Seating - Chairs



305152 - Chair, Altura, Guest, 25\"/>



305041 - Chair, Berlin, Black/White, 18\"/>



305042 - Chair, Berlin, Red/White, 18\"/>



305110 - Chair, Brewer, Black, 20\"/>



305109 - Chair, Brewer, Gray, 20\"/>



305217 - Chair, Casper, Clear, 21\"/>



305231 - Chair, Fusion, Clear/White, 19\"/>



305230 - Chair, Fusion, Green/White, 19\"/>



305232 - Chair, Fusion, Red/White, 19\"/>



305079 - Chair, Ice Transparent/Chrome, 17.25\"/>



305034 - Chair, Iso Mesh Black, 36\"/>



305111 - Chair, Jetson, 19\"/>



305149 - Chair, Luxor, Guest, 27\"/>



305113 - Chair, Manhattan, 26\"/>



305108 - Chair, New York, 23\"/>



305115 - Chair, Panton, White, 20\"/>



305078 - Chair, Stage, Beige, 24\"/>



305071 - Chair, Stage, Camel, 24\"/>



305077 - Chair, Stage, Onyx, 24\"/>



305075 - Chair, Stage, Red, 24\"/>



305069 - Chair, T-Vac Translucent, 25\"/>

Seating - Ottomans



305088 - Ottoman, Bench, Black, 24\"/>



305089 - Ottoman, Bench, White, 24\"/>



305085 - Ottoman, Cube, Black, 17\"/>



305093 - Ottoman, Cube, White Leather, 17\"/>



305086 - Ottoman, Half Round, Black, 72\"/>



305087 - Ottoman, Half Round, White, 72\"/>



305094 - Ottoman, Oval, Black, 52\"/>



305095 - Ottoman, Oval, White, 52\"/>



305240 - Ottoman, Puzzle Bench, White, 48\"/>



305092 - Ottoman, South Beach, Wedge, Platinum, 25\"/>



305090 - Ottoman, Square, Black, 40\"/>



305091 - Ottoman, Square, White, 40\"/>



305246 - Ottoman, Vibe Cube, Blue, Vinyl, 18\"/>



305242 - Ottoman, Vibe Cube, Champagne, Vinyl, 18\"/>



305243 - Ottoman, Vibe Cube, Gold/Bronze, Vinyl, 18\"/>



305241 - Ottoman, Vibe Cube, Green, Vinyl, 18\"/>



305244 - Ottoman, Vibe Cube, Pink, Vinyl, 18\"/>



305245 - Ottoman, Vibe Cube, Red, Vinyl, 18\"/>



305247 - Ottoman, Vibe Cube, Yellow, Vinyl, 18\"/>

Seating - Office and Utility Seating



305150 - Chair, Altura, High Back, 25\"/>



305151 - Chair, Altura, Med. Back, 25\"/>



305114 - Chair, Flex with Wheels, 24\"/>



305147 - Chair, Luxor, High Back, 27\"/>



305148 - Chair, Luxor, Med. Back, 27\"/>



305076 - Chair, Otto, Highback Black, 23\"/>



305126 - Chair, Task, 25\"/>



305112 - Chair, Tilt with Arms, Black, 26\"/>



305043 - Stool, Drafting, 25\"/>

Colors may vary due to facility lighting, printing limitations and dye lot differences. Some items may not be available at all locations. See order form for details. Styles of items portrayed on this brochure may vary in some locations.

Seating - Barstools



305012 - Barstool, Banana, Black, 21"L 22"D 30"H



305013 - Barstool, Banana, White, 21"L 22"D 30"H



305010 - Barstool, Gin, Maple, 16"L 16"D 29"H



305023 - Barstool, Ice, Transparent/Chrome, 16.75"L 16"D 32"H



305011 - Barstool, Jetson, Black, 18"L 19"D 29"H



305006 - Barstool, Ohio, Black, 18" Round 31"H Adj.



305007 - Barstool, Ohio, Grey, 18" Round 31"H Adj.



305005 - Barstool, Ohio, Red, 18" Round 31"H Adj.



305009 - Barstool, Oslo, Blue, 17"L 20"D 30"H



305008 - Barstool, Oslo, White, 17"L 20"D 30"H



305206 - Barstool, Shark Swivel, White/Chrome Base, 22"L 19"D 34"-44"H



305207 - Barstool, Zooey Swivel, White/Chrome Base, 15"Lx17"Dx31"-35"H

Table Surface Colors



Maple



Graphite Nebula



Grey Nebula



Metallic Silver



Brushed Red



Brushed Blue

Tables - Cafe



305162 - Table, Cafe, Blue/Black, 30" Round 29"H



305154 - Table, Cafe, Blue/Chrome, 30" Round 29"H



305164 - Table, Cafe, Graphite/Black, 30" Round 29"H



305167 - Table, Cafe, Graphite/Black, 36" Round 29"H



305156 - Table, Cafe, Graphite/Chrome, 30" Round 29"H



305159 - Table, Cafe, Graphite/Chrome, 36" Round 29"H



305166 - Table, Cafe, Grey/Black, 36" Round 29"H



305158 - Table, Cafe, Grey/Chrome, 36" Round 29"H



305165 - Table, Cafe, Maple/Black, 30" Round 29"H



305168 - Table, Cafe, Maple/Black, 36" Round 29"H



305157 - Table, Cafe, Maple/Chrome, 30" Round 29"H



305160 - Table, Cafe, Maple/Chrome, 36" Round 29"H



305161 - Table, Cafe, Red/Black, 30" Round 29"H



305153 - Table, Cafe, Red/Chrome, 30" Round 29"H



305163 - Table, Cafe, Silver/Black, 30" Round 29"H



305155 - Table, Cafe, Silver/Chrome, 30" Round 29"H

Colors may vary due to facility lighting, printing limitations and dye lot differences. Some items may not be available at all locations. See order form for details. Styles of items portrayed on this brochure may vary in some locations.

Tables - Bar



305131 - Table, Bar, Blue/Black, 30" Round 42"H



305140 - Table, Bar, Blue/Chrome, 30" Round 42"H



305133 - Table, Bar, Graphite/Black, 30" Round 42"H



305136 - Table, Bar, Graphite/Black, 36" Round 42"H



305142 - Table, Bar, Graphite/Chrome, 30" Round 42"H



305145 - Table, Bar, Graphite/Chrome, 36" Round 42"H



305135 - Table, Bar, Grey/Black, 36" Round 42"H



305144 - Table, Bar, Grey/Chrome, 36" Round 42"H



305134 - Table, Bar, Maple/Black, 30" Round 42"H



305137 - Table, Bar, Maple/Black, 36" Round 42"H



305143 - Table, Bar, Maple/Chrome, 30" Round 42"H



305146 - Table, Bar, Maple/Chrome, 36" Round 42"H



305130 - Table, Bar, Red/Black, 30" Round 42"H



305139 - Table, Bar, Red/Chrome, 30" Round 42"H



305132 - Table, Bar, Silver/Black, 30" Round 42"H



305141 - Table, Bar, Silver/Chrome, 30" Round 42"H

Tables - Cocktail



305017 - Table, Cocktail, Geo, Black, 50"L 22"D 16"H



305014 - Table, Cocktail, Geo, Chrome, 50"L 22"D 16"H



305020 - Table, Cocktail, Inspiration, 42"L 28"D 18"H



305210 - Table, Cocktail, Oliver, 47"L 27"D 19"H



305016 - Table, Cocktail, Silverado, 36" Round 17"H



305015 - Table, Cocktail, Soho, 38"L 38"D 18.5"H



305025 - Table, Cocktail, Sydney Black, 48"L 26"D 18"H



305024 - Table, Cocktail, Sydney White, 48"L 26"D 18"H

Tables - End Tables



305047 - Table, End, Geo, Black, 26"L 26"D 20"H



305044 - Table, End, Geo, Chrome, 26"L 26"D 20"H



305049 - Table, End, Inspiration, 24"L 28"D 22"H



305211 - Table, End, Oliver, 22" Round 22"H



305046 - Table, End, Silverado, 24" Round 22"H



305045 - Table, End, Soho, 26"L 26"D 27"H



305050 - Table, End, Sydney, Black, 27"L 23"D 22"H



305048 - Table, End, Sydney, White, 27"L 23"D 22"H

Conference Tables



305175 - Table, Conf., Geo, Black, 42"L 42"D 29"H



305176 - Table, Conf., Geo, Black, 60"L 36"D 29"H



305173 - Table, Conf., Geo, Chrome, 42"L 42"D 29"H



305174 - Table, Conf., Geo, Chrome, 60"L 36"D 29"H



305027 - Table, Conf., Graphite, 42" Round 29"H



305028 - Table, Conf., Graphite, 72"L 36"D 29"H



305029 - Table, Conf., Graphite, 96"L 36"D 29"H



305170 - Table, Conf., Gray, 42" Round 29"H



305171 - Table, Conf., Gray, 72"L 36"D 29"H

Colors may vary due to facility lighting, printing limitations and dye lot differences. Some items may not be available at all locations. See order form for details. Styles of items portrayed on this brochure may vary in some locations.



305172 - Table, Conf., Gray, 96\"L 36\"D 29\"H



305033 - Table, Conf., Mahogany, 120\"L 42\"W 29\"H



305030 - Table, Conf., Mahogany, 42\" Round, 42\"L 42\"W 29\"H



305031 - Table, Conf., Mahogany, 72\"L 42\"W 29\"H



305032 - Table, Conf., Mahogany, 96\"L 42\"W 29\"H



305177 - Table, Conf., Manhattan, 42\" Round 29\"H



305208 - Table, Nova, Oval, White/Silver Legs, 71\"L 35.5\"D 29\"H

Tables - Martini Bar



305004 - Table, Bar, Martini 3 pc., 100\"L 100\"D 47\"H



305003 - Table, Bar, Martini, 50\"L 50\"D 47\"H

Colors may vary due to facility lighting, printing limitations and dye lot differences. Some items may not be available at all locations. See order form for details. Styles of items portrayed on this brochure may vary in some locations.

Product Display



305002 - Bookcase, Graphite, 36"L 13"D 71"H



305001 - Bookcase, Mahogany, 36"L 13"D 71"H



305053 - Etagere, Black, 30"L 16"D 70"H



305052 - Etagere, Pewter, 30"L 16"D 70"H



305215 - Pedestal, Black Plastic, 24"L 24"D 36"H



305216 - Pedestal, Black Plastic, 24"L 24"D 42"H



305102 - Pedestal, Graphite, 30"L 30"D 42"H



305103 - Pedestal, Locking Door, Black, 24"L 24"D 42"H

Office and Utility Furniture



305040 - Credenza, Graphite, 72"L 24"D 29"H



305039 - Credenza, Mahogany, 72"L 24"D 29"H



305057 - Desk, Executive, Graphite, 60"L 30"D 29"H



305056 - Desk, Executive, Mahogany, 60"L 30"D 29"H



305138 - Desk, Writing, Graphite, 48"L 24"D 30"H



305059 - File, Lateral, Graphite, 36"L 20"D 29"H



305058 - File, Lateral, Mahogany, 36"L 20"D 29"H



305106 - Kiosk, Black/Maple, 24"L 21"D 42"H



305104 - Podium, Lectern, Cherry, 24"L 19"D 50"H



305038 - Table, Computer, Graphite, 36"L 30"D 42"H



305036 - Table, Training, Grey, 48"L 24"D 30"H

Colors may vary due to facility lighting, printing limitations and dye lot differences. Some items may not be available at all locations. See order form for details. Styles of items portrayed on this brochure may vary in some locations.

Lamps



305204 - Lamp, Floor,
Mason, Silver, 18" Round
55"H



305203 - Lamp, Floor,
Trovato, LED, White, 7"L
7"D 72"H



305205 - Lamp, Table,
Mason, Silver, 16" Round
26"H



305202 - Lamp, Table,
Trovato, White, 7"L 7"D
26"H

RETURN WITH G-2: PAYMENT & CREDIT CARD CHARGE AUTHORIZATION FORM TO:

Global Experience Specialists, Inc. (GES) • 7000 Lindell Road, Las Vegas, NV 89118-4702 • Fax: 866.329.1437 or 702.263.1520 for international exhibitors

All orders are governed by the GES Payment Policy and GES Terms & Conditions of Contract as specified in this Exhibitor Services Manual.
2013 Big O Tires Convention
 Phoenix Convention Center
 April 23, 2013

Discount Deadline Date:
 April 1, 2013

Price List							
ITEM#	DESCRIPTION	DISCOUNT PRICE	REGULAR PRICE	ITEM#	DESCRIPTION	DISCOUNT PRICE	REGULAR PRICE
Seating - Sofas and Loveseats				Seating - Ottomans			
305066	Loveseat, Black Leather, 64"L 36"D 34"H	\$ 633.00	\$ 950.00	305090	Ottoman, Square, Black, 40"L 40"D 17"H	\$ 307.00	\$ 461.00
305068	Loveseat, Key West, Black, 57"L 35"D 33"H	\$ 439.00	\$ 659.00	305091	Ottoman, Square, White, 40"L 40"D 17"H	\$ 307.00	\$ 461.00
305067	Loveseat, Newport, Charcoal Leather, 54"L 34"D 33"	\$ 694.00	\$ 1,040.00	305246	Ottoman, Vibe Cube, Blue, Vinyl, 18"L 18"D 18"H	\$ 109.00	\$ 164.00
305118	Sectional, 3 pc., Newport, Charcoal, 113"L 34"D 33"	\$ 1,370.00	\$ 2,060.00	305242	Ottoman, Vibe Cube, Champagne, Vinyl, 18"L 18"D	\$ 109.00	\$ 164.00
305120	Sectional, South Beach, 3 pc., Platinum, 152"L 40"D	\$ 1,270.00	\$ 1,910.00	305243	Ottoman, Vibe Cube, Gold/Bronze, Vinyl, 18"L 18"D	\$ 109.00	\$ 164.00
305236	Sofa, Allegro, Blue Fabric, 73"L 34.5"D 29.5"H	\$ 610.00	\$ 915.00	305241	Ottoman, Vibe Cube, Green, Vinyl, 18"L 18"D 18"H	\$ 109.00	\$ 164.00
305117	Sofa, Astro, 83"L 36"D 29"H	\$ 665.00	\$ 998.00	305244	Ottoman, Vibe Cube, Pink, Vinyl, 18"L 18"D 18"H	\$ 109.00	\$ 164.00
305125	Sofa, Key West, Black, 85"L 35"D 33"H	\$ 491.00	\$ 737.00	305245	Ottoman, Vibe Cube, Red, Vinyl, 18"L 18"D 18"H	\$ 109.00	\$ 164.00
305121	Sofa, Lisbon, Black Leather, 88"L 36"D 34"H	\$ 691.00	\$ 1,040.00	305247	Ottoman, Vibe Cube, Yellow, Vinyl, 18"L 18"D 18"H	\$ 109.00	\$ 164.00
305116	Sofa, Marrakesh, Light Beige, 84"L 37"D 34"H	\$ 596.00	\$ 894.00	Seating - Office and Utility Seating			
305124	Sofa, Memphis, 55"L 31"D 28"H	\$ 633.00	\$ 950.00	305150	Chair, Altura, High Back, 25"L 25"D 43"H Adj.	\$ 323.00	\$ 485.00
305226	Sofa, Mirabel, Brown Leather, 76"L 35"D 32"H	\$ 769.00	\$ 1,150.00	305151	Chair, Altura, Med. Back, 25"L 25"D 37"H Adj.	\$ 309.00	\$ 464.00
305221	Sofa, Roma, White Vinyl, 78"L 31"D 33"H	\$ 783.00	\$ 1,170.00	305114	Chair, Flex with Wheels, 24"L 22"D 31"H	\$ 144.00	\$ 216.00
305119	Sofa, South Beach, Platinum Suede, 69"L 29"D 33"H	\$ 575.00	\$ 863.00	305147	Chair, Luxor, High Back, 27"L 28"D 47"H Adj.	\$ 363.00	\$ 545.00
Seating - Club Chairs				305148	Chair, Luxor, Med. Back, 27"L 28"D 41"H Adj.	\$ 330.00	\$ 495.00
305235	Chair, Allegro, Blue Fabric, 36"L 34.5"D 29.5"H	\$ 483.00	\$ 725.00	305076	Chair, Otto, Highback Black, 23"L 21"D 43"H	\$ 412.00	\$ 618.00
305081	Chair, Astro Light Beige, 36"L 36"D 29"H	\$ 449.00	\$ 674.00	305126	Chair, Task, 25"L 26"D 21"H	\$ 130.00	\$ 195.00
305072	Chair, Barcelona, Black, 30"L 31"D 35"H	\$ 701.00	\$ 1,050.00	305112	Chair, Tilt with Arms, Black, 26"L 25"D 34"H	\$ 248.00	\$ 372.00
305073	Chair, Barcelona, White, 30"L 30"D 31"H	\$ 765.00	\$ 1,150.00	305043	Stool, Drafting, 25"L 26"D 34"H	\$ 191.00	\$ 287.00
305074	Chair, Cappuccino, 29"L 29"D 34"H	\$ 333.00	\$ 500.00	Seating - Barstools			
305180	Chair, Globus, 28"L 26"D 28"H	\$ 323.00	\$ 485.00	305012	Barstool, Banana, Black, 21"L 22"D 30"H	\$ 142.00	\$ 213.00
305178	Chair, Lisbon, Black Leather, 40"L 36"D 34"H	\$ 480.00	\$ 720.00	305013	Barstool, Banana, White, 21"L 22"D 30"H	\$ 142.00	\$ 213.00
305080	Chair, Marrakesh, Light Beige, 34"L 37"D 38"H	\$ 415.00	\$ 623.00	305010	Barstool, Gin, Maple, 16"L 16"D 29"H	\$ 184.00	\$ 276.00
305127	Chair, Memphis, 27.25"L 31.75"D 27.5"H	\$ 406.00	\$ 609.00	305023	Barstool, Ice, Transparent/Chrome, 16.75"L 16"D 32	\$ 194.00	\$ 291.00
305225	Chair, Mirabel, Brown Leather, 36"L 35"D 32"H	\$ 469.00	\$ 704.00	305011	Barstool, Jetson, Black, 18"L 19"D 29"H	\$ 235.00	\$ 353.00
305179	Chair, Newport, Charcoal Leather, 24"L 34"D 33"H	\$ 412.00	\$ 618.00	305006	Barstool, Ohio, Black, 18" Round 31"H Adj.	\$ 204.00	\$ 306.00
305220	Chair, Roma, White Vinyl, 37"L 31"D 33"H	\$ 484.00	\$ 726.00	305007	Barstool, Ohio, Grey, 18" Round 31"H Adj.	\$ 204.00	\$ 306.00
305070	Chair, Tub, Key West, Black, 31"L 31"D 31"H	\$ 339.00	\$ 509.00	305005	Barstool, Ohio, Red, 18" Round 31"H Adj.	\$ 204.00	\$ 306.00
305035	Corner, Charcoal Leather, 34"L 34"D 33"H	\$ 477.00	\$ 716.00	305009	Barstool, Oslo, Blue, 17"L 20"D 30"H	\$ 260.00	\$ 390.00
Seating - Chairs				305008	Barstool, Oslo, White, 17"L 20"D 30"H	\$ 260.00	\$ 390.00
305152	Chair, Altura, Guest, 25"L 20"D 34"H	\$ 266.00	\$ 399.00	305206	Barstool, Shark Swivel, White/Chrome Base, 22"L 1	\$ 349.00	\$ 524.00
305041	Chair, Berlin, Black/White, 18"L 22"D 32"H	\$ 109.00	\$ 164.00	305207	Barstool, Zooey Swivel, White/Chrome Base, 15"Lx1	\$ 319.00	\$ 479.00
305042	Chair, Berlin, Red/White, 18"L 22"D 32"H	\$ 109.00	\$ 164.00	Tables - Cafe			
305110	Chair, Brewer, Black, 20"L 20"D 32"H	\$ 132.00	\$ 198.00	305162	Table, Cafe, Blue/Black, 30" Round 29"H	\$ 200.00	\$ 300.00
305109	Chair, Brewer, Gray, 20"L 20"D 32"H	\$ 132.00	\$ 198.00	305154	Table, Cafe, Blue/Chrome, 30" Round 29"H	\$ 267.00	\$ 401.00
305217	Chair, Casper, Clear, 21"L 21"D 36.5"H	\$ 172.00	\$ 258.00	305164	Table, Cafe, Graphite/Black, 30" Round 29"H	\$ 200.00	\$ 300.00
305231	Chair, Fusion, Clear/White, 19"L 21"D 32"H	\$ 132.00	\$ 198.00	305167	Table, Cafe, Graphite/Black, 36" Round 29"H	\$ 234.00	\$ 351.00
305230	Chair, Fusion, Green/White, 19"L 21"D 32"H	\$ 132.00	\$ 198.00	305156	Table, Cafe, Graphite/Chrome, 30" Round 29"H	\$ 267.00	\$ 401.00
305232	Chair, Fusion, Red/White, 19"L 21"D 32"H	\$ 132.00	\$ 198.00	305159	Table, Cafe, Graphite/Chrome, 36" Round 29"H	\$ 317.00	\$ 476.00
305079	Chair, Ice Transparent/Chrome, 17.25"L 20"D 32"H	\$ 194.00	\$ 291.00	305166	Table, Cafe, Grey/Black, 36" Round 29"H	\$ 234.00	\$ 351.00
305034	Chair, Iso Mesh Black, 36"L 24"D 38"H	\$ 279.00	\$ 419.00	305158	Table, Cafe, Grey/Chrome, 36" Round 29"H	\$ 317.00	\$ 476.00
305111	Chair, Jetson, 19"L 18"D 31"H	\$ 176.00	\$ 264.00	305165	Table, Cafe, Maple/Black, 30" Round 29"H	\$ 200.00	\$ 300.00
305149	Chair, Luxor, Guest, 27"L 28"D 40"H	\$ 293.00	\$ 440.00	305168	Table, Cafe, Maple/Black, 36" Round 29"H	\$ 234.00	\$ 351.00
305113	Chair, Manhattan, 26"L 22"D 34"H	\$ 214.00	\$ 321.00	305157	Table, Cafe, Maple/Chrome, 30" Round 29"H	\$ 267.00	\$ 401.00
305108	Chair, New York, 23"L 32"D 33"H	\$ 182.00	\$ 273.00	305160	Table, Cafe, Maple/Chrome, 36" Round 29"H	\$ 317.00	\$ 476.00
305115	Chair, Panton, White, 20"L 34"D 33"H	\$ 192.00	\$ 288.00	305161	Table, Cafe, Red/Black, 30" Round 29"H	\$ 200.00	\$ 300.00
305078	Chair, Stage, Beige, 24"L 26"D 36"H	\$ 184.00	\$ 276.00	305153	Table, Cafe, Red/Chrome, 30" Round 29"H	\$ 267.00	\$ 401.00
305071	Chair, Stage, Camel, 24"L 26"D 36"H	\$ 184.00	\$ 276.00	305163	Table, Cafe, Silver/Black, 30" Round 29"H	\$ 258.00	\$ 387.00
305077	Chair, Stage, Onyx, 24"L 26"D 36"H	\$ 184.00	\$ 276.00	305155	Table, Cafe, Silver/Chrome, 30" Round 29"H	\$ 326.00	\$ 489.00
305075	Chair, Stage, Red, 24"L 26"D 36"H	\$ 184.00	\$ 276.00	Tables - Bar			
305069	Chair, T-Vac Translucent, 25"L 23"D 30"H	\$ 274.00	\$ 411.00	305131	Table, Bar, Blue/Black, 30" Round 42"H	\$ 209.00	\$ 314.00
Seating - Ottomans				305140	Table, Bar, Blue/Chrome, 30" Round 42"H	\$ 273.00	\$ 410.00
305088	Ottoman, Bench, Black, 24"L 60"D 17"H	\$ 369.00	\$ 554.00	305133	Table, Bar, Graphite/Black, 30" Round 42"H	\$ 209.00	\$ 314.00
305089	Ottoman, Bench, White, 24"L 60"D 17"H	\$ 369.00	\$ 554.00	305136	Table, Bar, Graphite/Black, 36" Round 42"H	\$ 256.00	\$ 384.00
305085	Ottoman, Cube, Black, 17"L 17"D 18"H	\$ 96.00	\$ 144.00	305142	Table, Bar, Graphite/Chrome, 30" Round 42"H	\$ 273.00	\$ 410.00
305093	Ottoman, Cube, White Leather, 17"L 17"D 18"H	\$ 94.25	\$ 141.00	305145	Table, Bar, Graphite/Chrome, 36" Round 42"H	\$ 320.00	\$ 480.00
305086	Ottoman, Half Round, Black, 72"L 36"D 17"H	\$ 368.00	\$ 552.00	305135	Table, Bar, Grey/Black, 36" Round 42"H	\$ 256.00	\$ 384.00
305087	Ottoman, Half Round, White, 72"L 36"D 17"H	\$ 368.00	\$ 552.00	305144	Table, Bar, Grey/Chrome, 36" Round 42"H	\$ 320.00	\$ 480.00
305094	Ottoman, Oval, Black, 52"L 32"D 19"H	\$ 288.00	\$ 432.00	305134	Table, Bar, Maple/Black, 30" Round 42"H	\$ 209.00	\$ 314.00
305095	Ottoman, Oval, White, 52"L 32"D 19"H	\$ 288.00	\$ 432.00	305137	Table, Bar, Maple/Black, 36" Round 42"H	\$ 256.00	\$ 384.00
305240	Ottoman, Puzzle Bench, White, 48"L 24"D 18"H	\$ 305.00	\$ 458.00	305143	Table, Bar, Maple/Chrome, 30" Round 42"H	\$ 273.00	\$ 410.00
305092	Ottoman, South Beach, Wedge, Platinum, 25"L 31"D	\$ 219.00	\$ 329.00	305146	Table, Bar, Maple/Chrome, 36" Round 42"H	\$ 320.00	\$ 480.00

Need Assistance?

Toll Free: 800.475.2098 | Tel: 702.515.5970 | www.ges.com/chat

 Order Directly Online:
<https://e.ges.com/017600137/esm>

RETURN WITH G-2: PAYMENT & CREDIT CARD CHARGE AUTHORIZATION FORM TO:

Global Experience Specialists, Inc. (GES) • 7000 Lindell Road, Las Vegas, NV 89118-4702 • Fax: 866.329.1437 or 702.263.1520 for international exhibitors

All orders are governed by the GES Payment Policy and GES Terms & Conditions of Contract as specified in this Exhibitor Services Manual.

2013 Big O Tires Convention

Phoenix Convention Center
April 23, 2013

Discount Deadline Date:

April 1, 2013

COMPANY NAME	EMAIL ADDRESS	BOOTH NUMBER
--------------	---------------	--------------

Price List

ITEM#	DESCRIPTION	DISCOUNT PRICE	REGULAR PRICE	ITEM#	DESCRIPTION	DISCOUNT PRICE	REGULAR PRICE
404200	GEM #3 10' x 10' Package <i>Includes: (1) 10' x 10' Standard Exhibit System, (1) 10' x 10' Standard 13oz Carpet, (3) Contemporary Stools, (1) Starbase Table 30"X40", (1) Wastebasket.</i>	\$ 3,351.40	\$ 5,027.00	404104	Bar Package <i>Includes: (2) White Oslo Barstools, (1) Martini Bar.</i>	\$ 1,570.00	\$ 2,360.00
404201	GEM #4 10' x 20' Package <i>Includes: (1) 10' x 20' Standard Exhibit System, (1) 10' x 20' Standard 13oz Carpet, (2) Contemporary Stools, (1) Wastebasket.</i>	\$ 6,509.40	\$ 9,764.00	404101	Barcelona Club Package <i>Includes: (2) Black Barcelona Chairs, (1) Inspiration End Table.</i>	\$ 1,673.00	\$ 2,507.00
404001	Chair Package A <i>Includes: (2) Contemporary Arm Chairs, (1) Starbase Table 40"X30", (1) Wastebasket.</i>	\$ 370.90	\$ 556.00	404103	Deluxe Chair Package <i>Includes: (2) New York Chairs, (1) Cafe Table 36"X29".</i>	\$ 681.00	\$ 1,022.00
404023	Display Case Package A <i>Includes: (2) Contemporary Stools, (1) Starbase Table 30"X40", (1) 6' Half View Display Case.</i>	\$ 883.00	\$ 1,325.00	404110	Newport Collection <i>Includes: (1) 3-Piece Newport Sectional (Charcoal Leather), (1) Soho Coffee Table.</i>	\$ 1,700.00	\$ 2,555.00
404024	Display Case Package B <i>Includes: (2) Contemporary Arm Chairs, (1) Starbase Table 40"X30", (1) 6' Half View Display Case.</i>	\$ 868.50	\$ 1,303.00	404107	Premium Chair Package <i>Includes: (2) Black Brewer Chairs, (1) Bar Table 36"X29".</i>	\$ 581.00	\$ 872.00
404011	Stool Package A <i>Includes: (2) Contemporary Stools, (1) Starbase Table 30"X40", (1) Wastebasket.</i>	\$ 385.40	\$ 578.00	404105	Premium Pedestal Package <i>Includes: (2) Black Banana Barstools, (1) Locking Pedestal.</i>	\$ 700.00	\$ 1,050.00
404002	Chair Package B <i>Includes: (2) Contemporary Arm Chairs, (1) 6' Skirted Table 24"X30", (1) Wastebasket.</i>	\$ 348.90	\$ 523.00	404106	Premium Stool Package <i>Includes: (2) White Banana Barstools, (1) Bar Table 30"X42".</i>	\$ 557.00	\$ 836.00
404012	Stool Package B <i>Includes: (2) Contemporary Stools, (1) 6' Skirted Counter 24"X42", (1) Wastebasket.</i>	\$ 379.40	\$ 569.00	404108	South Beach Club Collection <i>Includes: (1) White Half-Round Ottoman, (1) 3-Piece South Beach Sectional (Platinum Suede).</i>	\$ 1,638.00	\$ 2,462.00

Prices include delivery, installation, rental, and removal.
Cancellation Policy: Package items cancelled will be charged 50% of original price after move-in begins and 100% of original price after installation.

Please Indicate Choice

13 oz. Standard Carpet Colors (404200, 404201 ONLY).

Gray will be provided if no color is indicated below:

- Black (41) Blue (42) Blue Jay (56)
 Burgundy (43) Emerald Green (44) Gray (40)
 Pepper (52) Red (49)

Table Skirt Color (404002, 404012 ONLY).

Gray will be provided if no color is indicated below:

- Beige (54) Black (41) Blue (42)
 Burgundy (43) Forest Green (45) Gold (46)
 Gray (40) Mauve (47) Purple (48)
 Red (49) Teal (55) White (50)

Panel Type and Color (404200, 404201 ONLY).

Gray Fabric Panel will be provided if no color is indicated below:

- Coated: Black (C41) Coated: Oxford White (C50)
 Coated: Prism Blue (C42) Coated: Silver Gray (C79)
 Fabric: Black (F41) Fabric: Blue (F42)
 Fabric: Gray (F40)

Trim Metal Color (404200, 404201 ONLY).

Silver will be provided if no color is indicated below:

- Black (41) Silver (79)

Place Order Here

ITEM#	DESCRIPTION	PRICE	QUANTITY	TOTAL PRICE
				\$
				\$
				\$
				\$
A.	Total All Items Ordered			\$
B.	Petroleum Surcharge Assessment: 3%		A x 3% = B	\$
C.	Subtotal		A + B = C	\$
D.	Rental Tax: 9.3%		C x 9.3% = D	\$
E.	Payment Enclosed		C + D = E	\$

I agree in placing this order that I have accepted GES Payment Policy and GES Terms & Conditions of Contract.

Authorized Signature - Please Sign: X

AUTHORIZED NAME - PLEASE PRINT	DATE
--------------------------------	------

Need Assistance?

Toll Free: 800.475.2098 | Tel: 702.515.5970 | www.ges.com/chat



Order Directly Online:

<https://e.ges.com/017600137/esm>

With 5 GES® standard exhibits to choose from, selecting the size and configuration that meets your tradeshow needs is easy. Our modular exhibits are hassle-free because you pay no design fees, no shipping fees, and no repair or refurbishing fees. Plus, you may customize the trim and panels, and choose from a wide variety of accessories to create a unique exhibit that reinforces your brand and marketing efforts.

All packages include rental, delivery, installation, and dismantling. For other custom furnishings, hanging signs, or graphics, chat with your GES National Servicer® representative at www.ges.com/chat.

20x20 Exhibits

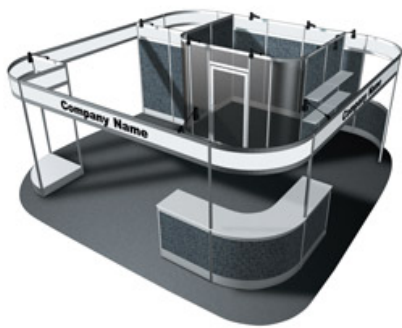

600005 - Exhibit System GEM #5, 20'x20' Island Includes:

- three digitally printed signs
- one locking office
- four shelves
- one curved counter
- two 1m counters
- ten arm lights
- one standard 20' x 20' carpet
- no padding

10x20 Exhibits



600004 - Exhibit System GEM #4, 10'x20' Inline Includes:

- one 116-7/8" x 12" digitally printed signs
- one 57-13/16" x 12" digitally printed signs
- one 2m counter
- six arm lights
- five shelves
- one standard 10' x 20' carpet
- no padding

10x10 Exhibits



600002 - Exhibit System GEM #2, 10'x10' Inline Includes:

- one custom ID sign
- two arm lights
- two shelves
- one standard 10' x 10' carpet
- no padding



600003 - Exhibit System GEM #3, 10'x10' Inline Includes:

- one custom ID sign
- three arm lights
- five shelves
- one 1m counter
- one standard 10' x 10' carpet
- no padding

6ft Table Display



600001 - Exhibit System GEM #1, 6' Tabletop Display Includes:

- one custom ID sign
- three arm lights
- two shelves
- one 6' skirted table
- no carpet and padding

Please note that although arm lights may be included in your package, electrical power must be ordered separately through the electrical services provider in your exhibitor service manual. Colors may vary due to facility lighting, printing limitations and dye lot differences.

Accessories



600410 - Exhibit, Ad Board, 1M x 8'



600110 - Exhibit, Armlight Black



600103 - Exhibit, Counter, 1M Curved



600101 - Exhibit, Counter, 1M x 1/2M x 40"H



600102 - Exhibit, Counter, 2M x 1/2M x 40"H



600221 - Exhibit, Light Box, Large 37"x85"



600222 - Exhibit, Light Box, Medium 37"x56"



600223 - Exhibit, Light Box, Small 37"x28"



661931 - Exhibit, Panel, Slatwall, 1M x 8'

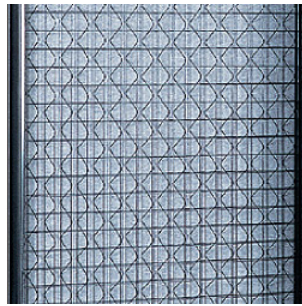







600291 - Exhibit, Panel, Wirewall, 1M



600243 - Exhibit, Shelf, 1M x 10" Deep

Trim and Panel Choices

Panel Type & Color

- | | | | |
|---|--|--|---|
|  Coated: Black (C41) |  Coated: Oxford White (C50) |  Coated: Prism Blue (C42) |  Coated: Silver Gray (C79) |
|  Fabric: Black (F41) |  Fabric: Blue (F42) |  Fabric: Gray (F40) | |

Trim Color

- | | |
|--|---|
|  Black (41) |  Silver (79) |
|--|---|

Please note that although arm lights may be included in your package, electrical power must be ordered separately through the electrical services provider in your exhibitor service manual. Colors may vary due to facility lighting, printing limitations and dye lot differences.

Exhibit #1, 6' Tabletop (600001)

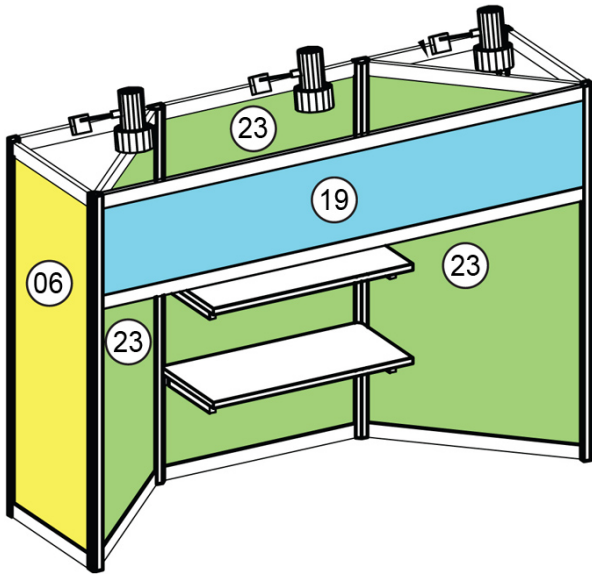

23 608323 26 9/16" wide x 45" tall

Discount Price - \$143.00 /Regular Price - \$215.00

Produced on 3/16" Thick White Foamcore

06 608306 18 7/16" wide x 45" tall

Discount Price - \$59.25 /Regular Price - \$89.00

Produced on 3/16" Thick White Foamcore

19 608319 65 15/16" wide x 12" tall

Discount Price - \$94.75 /Regular Price - \$142.00

Produced on 3/16" Thick White Foamcore

All Prices listed above are Per Panel.

Please note that pricing listed is for Graphic Panels only. GEM units are rented separately.

GES requires a form of payment on the booth graphic files in order to produce signage. Please see Digital File Preparation (1-2) for required information. Files uploaded to the GES FTP site without the required information will not be produced.

For additional questions, please contact:
Lamarr Gill
702.515.5781



Exhibit #2, 10 x 10 (600002)

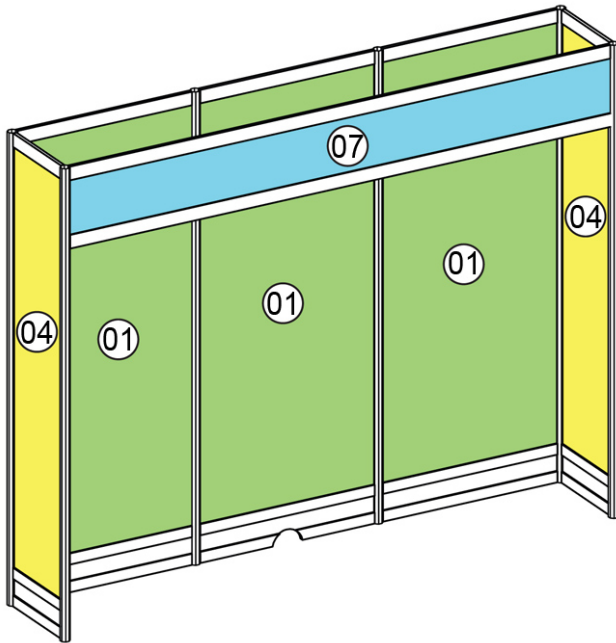

- 01** 608301 38 1/8" wide x 86 1/4" tall
Discount Price - \$393.00 /Regular Price - \$590.00
Produced on 3/16" Thick White Foamcore
- 04** 608304 18 7/16" wide x 86 1/4" tall
Discount Price - \$197.00 /Regular Price - \$296.00
Produced on 3/16" Thick White Foamcore
- 07** 608307 117" wide x 12" tall
Discount Price - \$168.00 /Regular Price - \$252.00
Produced on 3/16" Thick White Foamcore

All Prices listed above are Per Panel.

Please note that pricing listed is for Graphic Panels only. GEM units are rented separately.

GES requires a form of payment on the booth graphic files in order to produce signage. Please see Digital File Preparation (1-2) for required information. Files uploaded to the GES FTP site without the required information will not be produced.

For additional questions, please contact:
Lamarr Gill
702.515.5781



Please note that although arm lights may be included in your package, electrical power must be ordered separately through the electrical services provider in your exhibitor service manual. Colors may vary due to facility lighting, printing limitations and dye lot differences.

Exhibit #3, 10 x 10 (600003)

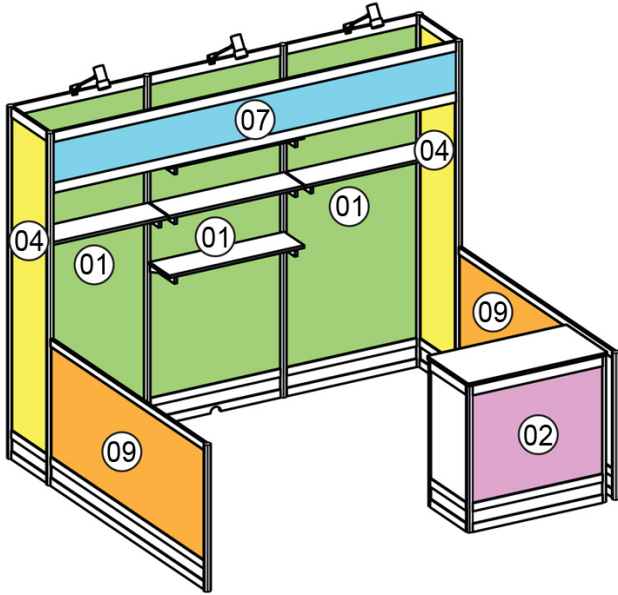

- 01** 608301 38 1/8" wide x 86 1/4" tall
Discount Price - \$393.00 /Regular Price - \$590.00
Produced on 3/16" Thick White Foamcore
- 04** 608304 18 7/16" wide x 86 1/4" tall
Discount Price - \$197.00 /Regular Price - \$296.00
Produced on 3/16" Thick White Foamcore
- 07** 608307 117" wide x 12" tall
Discount Price - \$168.00 /Regular Price - \$252.00
Produced on 3/16" Thick White Foamcore
- 02** 608302 38 1/8" wide x 30 1/4" tall
Discount Price - \$138.00 /Regular Price - \$207.00
Produced on 3/16" Thick White Foamcore
- 09** 608309 77 1/2" wide x 30 1/4" tall
Discount Price - \$280.00 /Regular Price - \$420.00
Produced on 3/16" Thick White Foamcore

All Prices listed above are Per Panel.

Please note that pricing listed is for Graphic Panels only. GEM units are rented separately.

GES requires a form of payment on the booth graphic files in order to produce signage. Please see Digital File Preparation (1-2) for required information. Files uploaded to the GES FTP site without the required information will not be produced.

For additional questions, please contact:
Lamarr Gill
702.515.5781



Exhibit #4, 10 x 20 (600004)

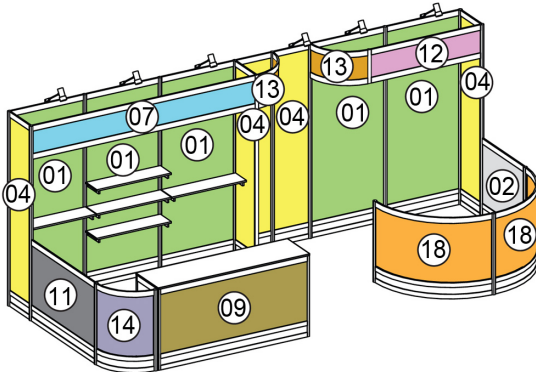

12 608312 57 7/8" wide x 12" tall

Discount Price - \$86.00 /Regular Price - \$129.00

Produced on 3/16" Thick White Foamcore

13 608313 29 3/4" wide x 12" tall

Discount Price - \$43.00 /Regular Price - \$64.50

Produced on 1/8" Thick White Foamacell

18 608318 60 3/4" wide x 30 1/4" tall

Discount Price - \$219.00 /Regular Price - \$329.00

Produced on 1/8" Thick White Foamacell

09 608309 77 1/2" wide x 30 1/4" tall

Discount Price - \$280.00 /Regular Price - \$420.00

Produced on 3/16" Thick White Foamcore

14 608314 29 3/4" wide x 30 1/4" tall

Discount Price - \$108.00 /Regular Price - \$162.00

Produced on 1/8" Thick White Foamacell

01 608301 38 1/8" wide x 86 1/4" tall

Discount Price - \$393.00 /Regular Price - \$590.00

Produced on 3/16" Thick White Foamcore

04 608304 18 7/16" wide x 86 1/4" tall

Discount Price - \$197.00 /Regular Price - \$296.00

Produced on 3/16" Thick White Foamcore

11 608311 57 7/8" wide x 30 1/4" tall

Discount Price - \$83.00 /Regular Price - \$125.00

Produced on 3/16" Thick White Foamcore

02 608302 38 1/8" wide x 30 1/4" tall

Discount Price - \$138.00 /Regular Price - \$207.00

Produced on 3/16" Thick White Foamcore

07 608307 117" wide x 12" tall

Discount Price - \$168.00 /Regular Price - \$252.00

Produced on 3/16" Thick White Foamcore



All Prices listed above are Per Panel.

Please note that pricing listed is for Graphic Panels only. GEM units are rented separately.

GES requires a form of payment on the booth graphic files in order to produce signage. Please see Digital File Preparation (I-2) for required information. Files uploaded to the GES FTP site without the required information will not be produced.

For additional questions, please contact:
Lamarr Gill
702.515.5781

Exhibit #5, 20 x 20 (600005)

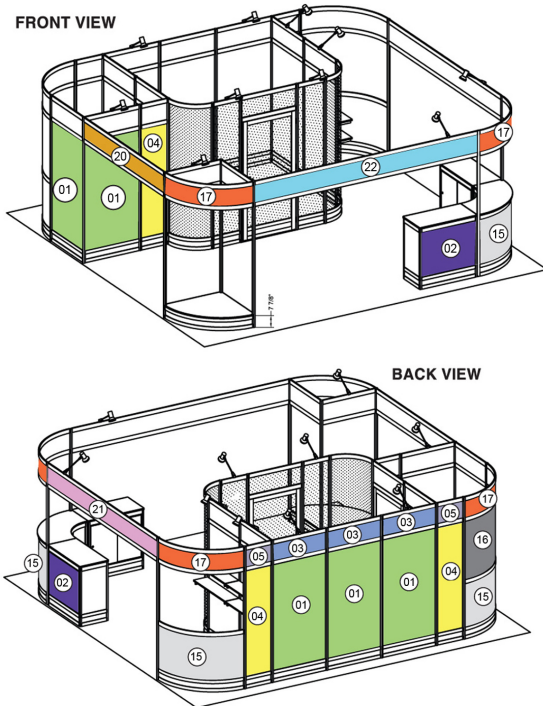

- 21** 608321 136 9/16" wide x 12" tall
Discount Price - \$129.00 /Regular Price - \$194.00
Produced on 3/16" Thick White Foamcore
- 20** 608320 97 3/16" wide x 12" tall
Discount Price - \$139.00 /Regular Price - \$209.00
Produced on 1/8" Thick White Foamcore
- 17** 608317 60 11/16" wide x 12" tall
Discount Price - \$161.00 /Regular Price - \$242.00
Produced on 1/8" Thick White Foamacell
- 02** 608302 38 1/8" wide x 30 1/4" tall
Discount Price - \$138.00 /Regular Price - \$207.00
Produced on 3/16" Thick White Foamcore
- 03** 608303 38 1/8" wide x 12" tall
Discount Price - \$54.75 /Regular Price - \$82.25
Produced on 3/16" Thick White Foamcore
- 05** 608305 18 7/16" wide x 12" tall
Discount Price - \$43.00 /Regular Price - \$64.50
Produced on 3/16" Thick White Foamcore

- 01** 608301 38 1/8" wide x 86 1/4" tall
Discount Price - \$393.00 /Regular Price - \$590.00
Produced on 3/16" Thick White Foamcore
- 04** 608304 18 7/16" wide x 86 1/4" tall
Discount Price - \$197.00 /Regular Price - \$296.00
Produced on 3/16" Thick White Foamcore
- 16** 608316 60 11/16" wide x 40 1/4" tall
Discount Price - \$263.00 /Regular Price - \$395.00
Produced on 1/8" Thick White Foamcell
- 15** 608315 60 11/16" wide x 30 1/4" tall
Discount Price - \$219.00 /Regular Price - \$329.00
Produced on 1/8" Thick White Foamcell
- 22** 608322 156 1/4" wide x 12" tall
Discount Price - \$223.00 /Regular Price - \$335.00
Produced on 3/16" Thick White Foamcore

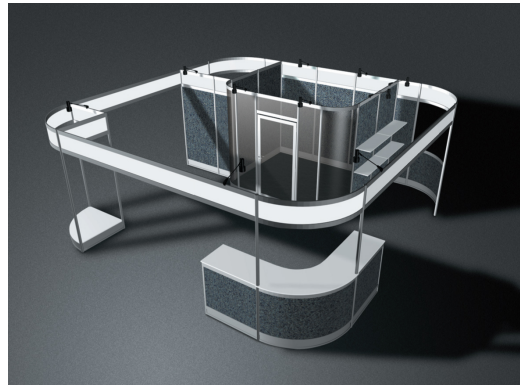

All Prices listed above are Per Panel.

Please note that pricing listed is for Graphic Panels only. GEM units are rented separately.

GES requires a form of payment on the booth graphic files in order to produce signage. Please see Digital File Preparation (I-2) for required information. Files uploaded to the GES FTP site without the required information will not be produced.

For additional questions, please contact:
Lamarr Gill
702.515.5781

RETURN WITH G-2: PAYMENT & CREDIT CARD CHARGE AUTHORIZATION FORM TO:

Global Experience Specialists, Inc. (GES) • 7000 Lindell Road, Las Vegas, NV 89118-4702 • Fax: 866.329.1437 or 702.263.1520 for international exhibitors

All orders are governed by the GES Payment Policy and GES Terms & Conditions of Contract as specified in this Exhibitor Services Manual.

2013 Big O Tires Convention

Phoenix Convention Center
April 23, 2013

Discount Deadline Date:

April 1, 2013

COMPANY NAME	EMAIL ADDRESS	BOOTH NUMBER
--------------	---------------	--------------

Price List

ITEM#	DESCRIPTION	DISCOUNT PRICE	REGULAR PRICE	ITEM#	DESCRIPTION	DISCOUNT PRICE	REGULAR PRICE
20x20 Exhibits				Accessories			
600005	Exhibit System GEM #5, 20'x20' Island	\$ 9,320.00	\$ 13,980.00	661931	Exhibit, Panel, Slatwall, 1M x 8'	\$ 432.00	\$ 648.00
10x20 Exhibits				600291	Exhibit, Panel, Wirewall, 1M	\$ 421.00	\$ 632.00
600004	Exhibit System GEM #4, 10'x20' Inline	\$ 6,280.00	\$ 9,420.00	600243	Exhibit, Shelf, 1M x 10" Deep	\$ 57.50	\$ 86.25
10x10 Exhibits				600262	Tackboard, Gem, 4' X 8'	\$ 495.00	\$ 743.00
600002	Exhibit System GEM #2, 10'x10' Inline	\$ 1,520.00	\$ 2,280.00	Cancellation Policy: Furniture Package items cancelled will be charged 50% of original price after move-in begins and 100% of original price after installation.			
600003	Exhibit System GEM #3, 10'x10' Inline	\$ 2,860.00	\$ 4,290.00				
6ft Table Display							
600001	Exhibit System GEM #1, 6' Tabletop Display	\$ 1,420.00	\$ 2,130.00				
Accessories							
600410	Exhibit, Ad Board, 1M x 8'	\$ 495.00	\$ 743.00				
600110	Exhibit, Armlight Black	\$ 73.25	\$ 110.00				
600103	Exhibit, Counter, 1M Curved	\$ 680.00	\$ 1,020.00				
600101	Exhibit, Counter, 1M x 1/2M x 40"H	\$ 344.00	\$ 516.00				
600102	Exhibit, Counter, 2M x 1/2M x 40"H	\$ 473.00	\$ 710.00				
600221	Exhibit, Light Box, Large 37"x85"	\$ 627.00	\$ 941.00				
600222	Exhibit, Light Box, Medium 37"x56"	\$ 496.00	\$ 744.00				
600223	Exhibit, Light Box, Small 37"x28"	\$ 306.00	\$ 459.00				

Please Indicate Choices

13 oz. Standard Carpet Colors (20x20 Exhibits, 10x20 Exhibits, 10x10 Exhibits ONLY).

Gray will be provided if no color is indicated below:

- Black (41) Blue (42) Blue Jay (56)
 Burgundy (43) Emerald Green (44) Gray (40)
 Pepper (52) Red (49)

Table Skirt Color (600001 ONLY).

Gray will be provided if no color is indicated below:

- Beige (54) Black (41) Blue (42)
 Burgundy (43) Forest Green (45) Gold (46)
 Gray (40) Mauve (47) Purple (48)
 Red (49) Teal (55) White (50)
 Black

Panel Type and Color (20x20 Exhibits, 10x20 Exhibits, 10x10 Exhibits, 600410, 600103, 600101, 600102, 600221, 600222, 600223 ONLY).

Gray Fabric Panel will be provided if no color is indicated below:

- Coated: Black (C41) Coated: Oxford White (C50)
 Coated: Prism Blue (C42) Coated: Silver Gray (C79)
 Fabric: Black (F41) Fabric: Blue (F42)
 Fabric: Gray (F40)

Trim Metal Color (20x20 Exhibits, 10x20 Exhibits, 10x10 Exhibits, 600410, 600103, 600101, 600102, 600221, 600222, 600223 ONLY).

Silver will be provided if no color is indicated below:

- Black (41) Silver (79)

Electrical or Utilities Under Carpet?

- Yes No

The leaf symbol indicates recyclable or eco-friendly materials per manufacturer's specifications.

Cancellation Policy: Custom Size Booth Carpet cancelled after being cut will be charged 100%. All other carpet cancelled will be charged 50% of original price after move-in begins and 100% of original price after installation.

For Additional Custom Graphics, please go to <http://www.ges.com/graphics/quote/>
For Custom Exhibits, please send a request to email gesed@ges.com

Place Order Here

ITEM#	DESCRIPTION	PRICE	QUANTITY	TOTAL PRICE
				\$
				\$
				\$
A.	Total All items Ordered			\$
B.	Petroleum Surcharge Assessment: 3%		A x 3% = B	\$
C.	Subtotal		A + B = C	\$
D.	Rental Tax: 9.3%		C x 9.3% = D	\$
E.	Payment Enclosed		C + D = E	\$

I agree in placing this order that I have accepted GES Payment Policy and GES Terms & Conditions of Contract.

Authorized Signature - Please Sign: X

AUTHORIZED NAME - PLEASE PRINT DATE

CUSTOM ID SIGN

Colored signs are available at additional cost, please go to http://www.ges.com/ecomm/info/exhibit_graphics.pdf for example. An EPS Vector format file, with all the fonts converted to outline, and hard copy must be received with this order to receive a Custom ID Sign. Please review "I-2: Digital File Submission Guide" within this manual for additional information and instructions.

STANDARD ID SIGN COPY

Signs will be black text on white background.

If Custom ID is not required, please indicate ID copy. Print or type.



All orders are governed by the GES Payment Policy and GES Terms & Conditions of Contract as specified in this Exhibitor Services Manual.

2013 Big O Tires Convention

Phoenix Convention Center
April 23, 2013

We want your graphics and images to look their absolute best. We are committed to partnering with you in order to provide the most comprehensive and effective solutions in the trade show industry. The graphic print and production industry is continuously evolving. In order to insure the best quality graphics and images from your digital files, and to make file transfers as seamless as possible, we are pleased to provide you with guidelines for submission of your art to Graphics Production. If you are unable to provide digital artwork for your signage needs, we are capable of providing you with layout services. Additional fees will apply. Please contact GES for details.

Suitable Formats for images or logos	
Program	Preferred Format
Adobe Illustrator CS4	ai, eps
Adobe Photoshop CS4	tiff (LZW), jpeg (high quality)
Adobe InDesign CS4	indd (include all links)
Adobe Acrobat	PDF (press quality setting)
QuarkXPress 7	qxd (include all links)

Suitable Media for images or logos	
Media	Preferred Format
CD-ROM (CD-R or CD-RW)	Please send hard copy color proofs
DVD-ROM (DVD-R or DVD-RW)	Please send hard copy color proofs
Email Attachments	Limited to maximum size of 5MB
FTP	Mandatory zip or sit compression

AVOIDING ADDITIONAL COSTS:

Files obtained from the internet (.jpg or .gif) or artwork created in MS Office applications (Word, Excel, PowerPoint, etc.) are often not suitable for high quality output, and often require additional hourly charges. Artwork should be created at actual size, however, for larger files i.e., banner artwork, 10% or 25% of actual size is acceptable. Scans should be no smaller than 300dpi at quarter size. To avoid additional costs associated with these file types, please supply files in accordance with the defined herein.



Vector Artwork

For the best quality, artwork should be created in **vector format (ai or vector eps)**. Logos taken from websites are generally gifs. **Gif files are not acceptable as they will not print clearly.** See Visual.

Artwork which is going to be produced in vinyl, for example; solid company logo's or text, must be supplied in a **vector format (ai or vector eps)**. Artwork created in a pixel format, i.e., TIFF and JPEG is not suitable. See Visual.

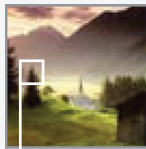

Bitmap/Raster Artwork

JPEG - We accept this format but only if used to compress a file for ease of sending, the original artwork should have been created high resolution - **300dpi or vector eps to print at the best possible quality.** See Visual.

PDF - These are print files only and can not be altered to fit different sizes, artwork must be set up at the correct proportion and at print ready quality. Make sure images are saved at high resolution (300dpi). See Visual.

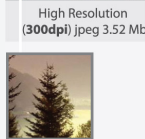
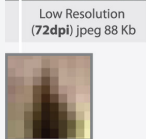

Color Set Up

If your artwork is using PANTONE Colors, please supply a Pantone color reference. Some colors are more likely to be achieved, but due to printer limitations, Pantone colors are matched to the best possible interpretation for the specific output device. Hard copies such as brochures or print outs can be used as a reference for color matching.

Fonts

Turn all fonts into outlines or convert to paths before sending the files. If you are using a program where this is not an option, **YOU MUST INCLUDE ALL FONTS** with your files.

FTP (File Transfer Protocol) Information

You can upload your file(s) after sending in your order using the information below.

	HOST	USER NAME:	PASSWORD:
Western Region Shows	ftp://csftp.ges.com/West	geswstftp	o8clx6eq

Please make sure your file(s) are labeled with the exhibiting company's name and the show name (e.g. EGGWHITES_COOKING SHOW.zip)



38" Ad Board

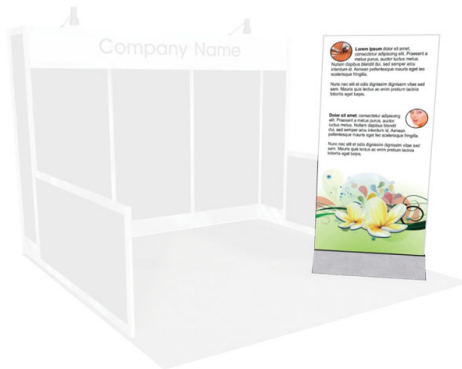

- 600527 Freestanding 38"W x 84"H Vertical Ad Board w/ Cardboard Base, Single Sided (includes cardboard base, graphic & delivery)
 - 600529 Freestanding 38"W x 84"H Vertical Ad Board w/ Cardboard Base, Double Sided
- Includes cardboard base, graphic and delivery.
Printed base available at additional cost.*

24" Ad Board

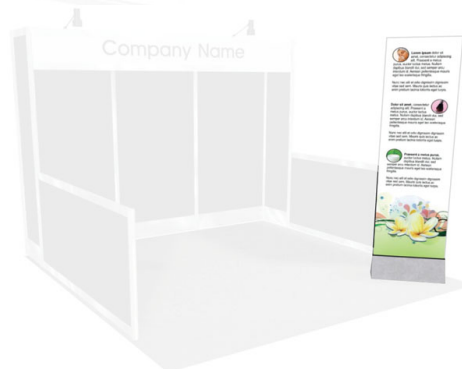

- 600526 Freestanding 24"W x 84"H Vertical Ad Board w/ Cardboard Base, Single Sided (includes cardboard base, graphic & delivery)
 - 600528 Freestanding 24"W x 84"H Vertical Ad Board w/ Cardboard Base, Double Sided
- Includes cardboard base, graphic and delivery.
Printed base available at additional cost.*

22" x 28" with Sign Holder

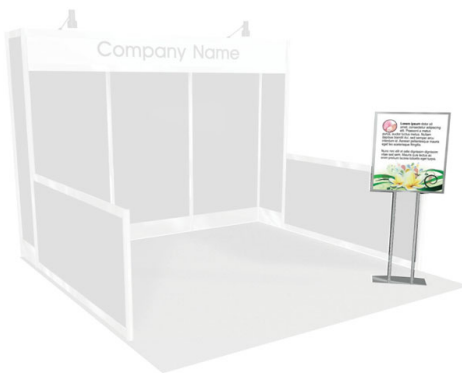

- 600533 22"W x 28"H Vertical Sign w/ Sign Holder, Single Sided
- 600534 22"W x 28"H Vertical Sign w/ Sign Holder, Double Sided

Includes sign holder rental, graphic and delivery.

6' x 3' Banner



- 600535 72"W x 36"H Vinyl Banner (horizontal or vertical) w/ Silver Grommets, Single Sided

*Banner is available horizontal or vertical.
Includes silver grommets.*

RETURN WITH G-2: PAYMENT & CREDIT CARD CHARGE AUTHORIZATION FORM TO:

Global Experience Specialists, Inc. (GES) • 7000 Lindell Road, Las Vegas, NV 89118-4702 • Fax: 866.329.1437 or 702.263.1520 for international exhibitors

All orders are governed by the GES Payment Policy and GES Terms & Conditions of Contract as specified in this Exhibitor Services Manual.

2013 Big O Tires Convention

Phoenix Convention Center
April 23, 2013

Discount Deadline Date:

April 1, 2013

Go to below link to view images and information:
<http://ges.com/ecommerce/info/landD.pdf>

COMPANY NAME	EMAIL ADDRESS	BOOTH NUMBER
SHOWSITE CONTACT	SHOWSITE CONTACT PHONE #	DATE/TIME OF ARRIVAL
CONTACT'S HOTEL (OPTIONAL)		

**PLEASE COMPLETE THIS FORM FOR ALL DISPLAY LABOR NEEDED.
TO DETERMINE IF YOU NEED DISPLAY LABOR, PLEASE READ THIS FORM CAREFULLY.**

- Display Labor is required for all installation and dismantling of exhibits, including signs and floor covering installation.
- Exhibitor may unpack and place merchandise.
- Exhibitor may set up exhibit display if one person can accomplish the task in less than one-half (½) hour without the use of tools.

Important Information & Rates

Starting time can be guaranteed only when labor is requested for the start of the working day. All exhibit labor scheduled at the start of the working day will be dispatched to booth space. For all other starting times, check in at the labor desk one-half (½) hour before time requested. Labor cancelled without a 24 hour notice shall be charged a one (1) hour cancellation fee per worker. If Exhibitor fails to use the workers at the time confirmed, a one (1) hour "No-Show" charge per worker will apply.

The minimum charge for labor is one (1) hour per worker. Labor thereafter is charged in half (½) hour increments. Gratuities in any form, including cash, gifts, or labor hours for work not actually performed are prohibited by GES. GES requires the highest standards of integrity from all employees. Please call our confidential Always Honest hotline at 866.225.8230 to report fraudulent or unethical behavior. All rates are subject to change if necessitated by increased labor and material costs.

LABOR RATES ARE AS FOLLOWS:

Worker per Hour	Discount	Regular	Show Site
Install & Dismantle, ST Code: 705000	\$ 91.00	\$ 114.00	\$ 137.00
Install & Dismantle, OT Code: 705000	\$ 137.00	\$ 171.00	\$ 206.00
Install & Dismantle, DT Code: 705000	\$ 182.00	\$ 228.00	\$ 273.00

- Straight Time:** Monday through Friday from 8:00 AM to 4:30 PM.
Overtime: Monday through Friday from 7:00 AM to 8:00 AM and 4:30 PM to 11:59 PM. All day Saturday & Sunday.
Double Time: All other times Monday through Friday. All day Holidays.
Discount Rate: Rate applies to orders placed on or before the above Discount Deadline Date.
Regular Rate: Rate applies to orders placed after the above Discount Deadline Date, but before the first day of exhibitor move-in.
Show Site Rate: Rate applies to orders placed at show site

Please Indicate Service

GES Supervised (OK to Proceed)
Please complete "Key Information" form (L-2)

GES will supervise labor to:

- Unpack and install display before Exhibitor arrival at show site.
- Dismantle and pack the display after show closing.
- Subject to terms and conditions of all GES policies, including terms and conditions of contract, including but not limited to sub-paragraph VII, b., Labor.

A 25% (\$50.00 minimum) surcharge will be added to the labor rates above for this professional supervision.

LOCATION OF BOOTH/DIMENSION OF BOOTH: Use the Booth Layout Form to represent your booth, indicate from each boundary how you would like your booth placed.

Exhibitor Supervised (Do Not Proceed)

Exhibitor will supervise.

- Indicate workers needed for installation **and** dismantling
- GES assumes no liability for loss, damage or bodily injury arising out of the installation and/or dismantling of Exhibitor's property by GES provided union labor. Exhibitor assumes the responsibility and any liability arising therefrom, for the work performed by union labor under Exhibitor's supervision. Exhibitors must stay clear during movement of freight.

GES is responsible for the following type of booth:

- Pop-Up Two Story Custom
 Other: _____

Place Order Here

SCHEDULE DATE(S)	SCHEDULE START TIME	SCHEDULE END TIME	TOTAL # OF HOURS	TOTAL # OF WORKERS	LABOR RATE	TOTAL	3% PSP	GRAND TOTAL
	AM PM	AM PM						\$
	AM PM	AM PM						\$
I agree in placing this order that I have accepted GES Payment Policy and GES Terms & Conditions of Contract.						A.	Total Labor Ordered	\$
Authorized Signature - Please Sign:						B.	25% (\$50.00 min) GES Supervision	\$
<input checked="" type="checkbox"/>	AUTHORIZED NAME - PLEASE PRINT				DATE	C.	Payment Enclosed	\$

Please estimate the number of workers and hours per worker needed for installation and dismantling above. Invoice will be calculated according to actual hours worked, relative to the original estimate and based upon the date received. Additional labor required will be calculated and invoiced at the show site rate.



RETURN TO: Global Experience Specialists, Inc. (GES) • 7000 Lindell Road, Las Vegas, NV 89118-4702 • Fax: 866.329.1437 or 702.263.1520 for international exhibitors
 Contact us Online: www.ges.com/chat Phone: 800.475.2098 or 702.515.5970 for international exhibitors

All orders are governed by the GES Payment Policy and GES Terms & Conditions of Contract as specified in this Exhibitor Services Manual.

2013 Big O Tires Convention

Phoenix Convention Center
 April 23, 2013

Form Deadline Date:
 April 1, 2013

MANDATORY FORM*

COMPANY NAME	EMAIL ADDRESS	BOOTH NUMBER
--------------	---------------	--------------

To Be Completed By Exhibitor When Order is Placed

Inbound Freight Information

Method GES Logistics Common Carrier AirFreight Vanline Other _____
 Carrier (if known) _____
 Contact _____ Phone _____
 Number of Crates _____ Shipped By _____ Date _____
 Number of Fiber Cases _____ Color _____ Pro Number _____
 Target Date _____ Loose Display _____ Crated Display _____
 Shipped To: (Check One) Warehouse Showsite

Setup Information for GES Installation

<input type="checkbox"/> Setup Drawings/Instructions Attached <input type="checkbox"/> Setup Drawings With Exhibit <input type="checkbox"/> Case/Crate Number _____ <input type="checkbox"/> Number of Workers Required for Setup _____ <input type="checkbox"/> Forklift Ordered Hrs. _____ Time _____ <input type="checkbox"/> Number of Graphics _____ Layout Provided? <input type="checkbox"/> Yes <input type="checkbox"/> No <input type="checkbox"/> Number of Lights _____ Number of Light Boxes _____	<input type="checkbox"/> Rental Carpet Color _____ <input type="checkbox"/> Own Carpet Color _____ <input type="checkbox"/> Padding _____ Approximate Time for Setup _____ Special Equipment Required _____ Description _____ Description _____
---	---

Did You Order ---

Electrical Outlets Yes No Electrical Labor/Boothwork Yes No Electrical Under Carpet Yes No
 Electrical Drawings Attached Sent to the Official Electrical Contractor With the Exhibit
 Booth Cleaning Yes No Other Items _____
 Furniture Yes No
 A/V Equipment Yes No
 Telephone/Internet Yes No

Tear-down Information for GES Dismantle

<input type="checkbox"/> Tear-down Drawings/Instructions Attached <input type="checkbox"/> Tear-down Drawings With Exhibit <input type="checkbox"/> Case/Crate Number _____ <input type="checkbox"/> Number of Workers Required for Tear- down _____ <input type="checkbox"/> Forklift Ordered Hrs. _____ Time _____ <input type="checkbox"/> Number of Graphics _____ Layout Provided? <input type="checkbox"/> Yes <input type="checkbox"/> No <input type="checkbox"/> Number of Lights _____ Number of Light Boxes _____	<input type="checkbox"/> Rental Carpet Color _____ <input type="checkbox"/> Own Carpet Color _____ <input type="checkbox"/> Padding _____ Approximate Time for Tear-down _____ Special Equipment Required _____ Description _____ Description _____
--	---

Outbound Freight Information

Outbound Freight Charges _____ Consigned To _____
 PrePaid Collect (for non-GES Logistics Shipments only) Address _____
 Bill To _____ City/State/Zip _____
 _____ Second Consignee _____
 _____ Address _____
 GES Storage _____ City/State/Zip _____
 Method GES Logistics Common Carrier AirFreight Vanline Other _____
 Carrier (if known) _____
 Contact _____ Phone _____
 Exhibitor-completed GES' Outbound Material Handling Form attached: Yes No
 Exhibitor will pack all product, prepare shipping labels and complete GES' Outbound Material Handling Form attached: Yes No

Emergency Contact Information / Showsite Contact

Name _____ Title _____
 Telephone _____ Cell Phone _____
 Other Means of Contacting This Person _____
 Contact's Hotel _____ Arrival _____ Departure _____
 Purchasing Authorization Yes No

*This Form must be returned to GES for your orders to be processed.

I agree in placing this order that I have accepted GES Payment Policy and GES Terms & Conditions of Contract.

Authorized Signature - Please Sign: _____ X

AUTHORIZED NAME - PLEASE PRINT	DATE
--------------------------------	------

Need Assistance?

Toll Free: 800.475.2098 | Tel: 702.515.5970 | www.ges.com/chat

Order Directly Online:
<https://e.ges.com/017600137/esm>

017600137

RETURN WITH G-2: PAYMENT & CREDIT CARD CHARGE AUTHORIZATION FORM TO:

Global Experience Specialists, Inc. (GES) • 7000 Lindell Road, Las Vegas, NV 89118-4702 • Fax: 866.329.1437 or 702.263.1520 for international exhibitors

All orders are governed by the GES Payment Policy and GES Terms & Conditions of Contract as specified in this Exhibitor Services Manual.

2013 Big O Tires Convention

Phoenix Convention Center

April 23, 2013

Discount Deadline Date:

April 1, 2013

COMPANY NAME	EMAIL ADDRESS	BOOTH NUMBER
SHOWSITE CONTACT	SHOWSITE CONTACT PHONE #	DATE/TIME OF ARRIVAL
		CONTACT'S HOTEL (OPTIONAL)

PLEASE COMPLETE THIS FORM FOR ALL IN-BOOTH FORKLIFT AND LABOR NEEDED. TO DETERMINE IF YOU NEED IN-BOOTH FORKLIFT AND LABOR, PLEASE READ THIS FORM CAREFULLY.

- In-booth forklift and Labor may be required to assemble displays or when uncrating, positioning, and reskidding equipment and machinery.
- A forklift is required for moving equipment and materials weighing 200 pounds or more.
- If you require a forklift, a crew will be assigned consisting of a forklift with an operator.

Important Information & Rates

Starting time can be guaranteed only when labor is requested for the start of the working day at 8:00 AM. All exhibit labor for 8:00 AM starting times will be dispatched to booth space. Confirm labor and forklifts by 2:30 PM the day before date requested. Please have a representative pick up the crew at the labor desk and supervise the work to be done. Upon completion, the Exhibitor's representative will return the crew to the labor desk and approve the work order. Equipment and labor cancelled without a 24 hour notice shall be charged a one (1) hour cancellation fee per worker and forklift. If Exhibitor fails to use the workers and equipment at the time confirmed, a one (1) hour cancellation fee per worker and forklift will apply.

The minimum charge for labor is one (1) hour per worker and equipment. Labor thereafter is charged in half (½) hour increments per worker and equipment. Gratuities in any form, including cash, gifts, or labor hours for work not actually performed are prohibited by GES. GES requires the highest standards of integrity from all employees. Please call our confidential Always Honest hotline at 866.225.8230 to report fraudulent or unethical behavior. All rates are subject to change if necessitated by increased labor and material costs.

LABOR RATES ARE AS FOLLOWS:

Forklift w/Operator Per Hour	Discount	Regular	Show Site
5,000#, ST Code: 705200	\$ 218.50	\$ 273.00	\$ 328.00
5,000#, OT Code: 705200	\$ 306.00	\$ 383.00	\$ 459.00
5,000#, DT Code: 705200	\$ 551.00	\$ 689.00	\$ 827.00

Worker per Hour	Discount	Regular	Show Site
Freight, ST Code: 705030	\$ 91.00	\$ 114.00	\$ 137.00
Freight, OT Code: 705030	\$ 137.00	\$ 171.00	\$ 206.00
Freight, DT Code: 705030	\$ 274.00	\$ 343.00	\$ 411.00

*Rates include taxes for equipment used.

- Straight Time:** Monday through Friday from 8:00 AM to 4:30 PM.
Overtime: All other times Monday through Friday. All day Saturday & Sunday.
Double Time: All day Holidays.
Discount Rate: Rate applies to orders placed on or before the above Discount Deadline Date.
Regular Rate: Rate applies to orders placed after the above Discount Deadline Date, but before the first day of exhibitor move-in.
Show Site Rate: Rate applies to orders placed at show site

Please Indicate Service

 Exhibitor Supervised (Do Not Proceed)

- Exhibitor will supervise.
- Indicate workers needed for installation **and** dismantling
 - GES assumes no liability for loss, damage or bodily injury arising out of the installation and/or dismantling of Exhibitor's property by GES provided union labor. Exhibitor assumes the responsibility and any liability arising therefrom, for the work performed by union labor under Exhibitor's supervision. Exhibitors must stay clear during movement of freight.

GES is responsible for the following type(s) of work:

- | | | |
|-------------------------------------|--------------------------------------|--------------------------------------|
| <input type="checkbox"/> Uncrating | <input type="checkbox"/> Unskidding | <input type="checkbox"/> Positioning |
| <input type="checkbox"/> Leveling | <input type="checkbox"/> Dismantling | <input type="checkbox"/> Recrating |
| <input type="checkbox"/> Reskidding | | |

Place Order Here

SCHEDULE DATE(S)	SCHEDULE START TIME	SCHEDULE END TIME	TOTAL # OF HOURS	TOTAL # OF FORKLIFTS	LABOR RATE	TOTAL	3% PSP	GRAND TOTAL
	AM PM	AM PM						\$
	AM PM	AM PM						\$
	AM PM	AM PM						\$
	AM PM	AM PM						\$

I agree in placing this order that I have accepted GES Payment Policy and GES Terms & Conditions of Contract.

Payment Enclosed

\$

Authorized Signature - Please Sign:

X	AUTHORIZED NAME - PLEASE PRINT
	DATE

Please estimate the number of workers and hours per worker needed for installation and dismantling above. Invoice will be calculated according to actual hours worked, relative to the original estimate and based upon the date received. Additional labor required will be calculated and invoiced at the show site rate.

Need Assistance?

Toll Free: 800.475.2098 | Tel: 702.515.5970 | www.ges.com/chat

 Order Directly Online:
<https://e.ges.com/017600137/esm>

All orders are governed by the GES Payment Policy and GES Terms & Conditions of Contract as specified in this Exhibitor Services Manual.

2013 Big O Tires Convention

Phoenix Convention Center
April 23, 2013

Hanging Signs

GES is responsible for assembly, installation, and removal of all hanging signs, unless it requires a chain motor.

Remember:

1. All signs must be designed to comply with Show Organizer rules and regulations and facility limitations.
2. Make sure all signs, with the exception of cloth banners and signs under 100 lbs., have structurally engineered rigging points as well as blueprints displaying a current structural engineer's stamp.
3. If your sign requires electricity, make sure it is in working order and in accordance with the National Electric Code. Place your order for electrical services and electrical labor on the Electrical Service Order Form.
4. Include Exhibitor contact information with the order.
5. **Include engineer-stamped assembly and hanging instructions with the order. GES accepts no liability for any work completed without such instructions, when required. Work is done at Exhibitor's risk and Exhibitor shall indemnify and defend GES and Show Organizer from any claims arising out of or related to the installation or dismantle of any sign without approved drawings.**

Truss Information

GES is responsible for assembly, installation, and removal of all trusses that do not require a chain motor.

If you wish your representative to be present during the assembly, installation, and removal of your truss, please check the appropriate box on the Hanging Sign / Truss Labor Order Form (H-2).

Remember:

1. All trusses must be designed to comply with Show Organizer rules and regulations and facility limitations.
2. All trusses must be from a recognized manufacturer. Manufacturer load specifications for your truss must be at show site prior to rigging.
3. Climbing on truss is strictly prohibited.
4. All lamps and fixtures to be attached to truss must be in good working order and in compliance with the National Electric Code. Place your order for electrical services and electrical labor on the Electrical Service Order Form.

Please complete and return the
Hanging Sign / Assembly Labor Order Form (H-2) April 1, 2013.

To receive the Discount Price, you must complete and return the Hanging Sign / Assembly Labor Order Form with Hanging Sign instructions and the Payment & Credit Card Charge Authorization by April 1, 2013. The hanging sign must also arrive at the GES warehouse by April 17, 2013 to receive the Discount Price and to ensure that the sign is hung prior to show opening. THERE IS NO GUARANTEE THAT YOUR SIGN WILL BE HUNG IF IT IS NOT RECEIVED BY THE DEADLINE DATE. By sending us this information and shipping the sign in advance, you will help assure your sign is properly assembled and installed.

Shipping Instructions

Please ship your hanging signs in advance. All hanging signs must be received in advance at the GES warehouse by April 17, 2013 to receive the Discount Price. Please ship all hanging signs in a separate container with the special sign label enclosed in this exhibitor services manual. Mark bills of lading "Hanging Sign". Prepay all shipments. Collect shipments will not be accepted. See *Shipping Information and Shipping Guidelines* for more information.

Please call for information on advance shipping for all uncrateable signs.

To expedite the hanging sign, please use the special shipping labels located in this section of this exhibitor service manual.

RETURN WITH G-2: PAYMENT & CREDIT CARD CHARGE AUTHORIZATION FORM TO:

Global Experience Specialists, Inc. (GES) • 7000 Lindell Road, Las Vegas, NV 89118-4702 • Fax: 866.329.1437 or 702.263.1520 for international exhibitors

All orders are governed by the GES Payment Policy and GES Terms & Conditions of Contract as specified in this Exhibitor Services Manual.

2013 Big O Tires Convention
 Phoenix Convention Center
 April 23, 2013

Discount Deadline Date:
 April 1, 2013

COMPANY NAME	EMAIL ADDRESS	BOOTH NUMBER
SHOWSITE CONTACT	SHOWSITE CONTACT PHONE #	DATE/TIME OF ARRIVAL
CONTACT'S HOTEL (OPTIONAL)		

GES IS RESPONSIBLE FOR ASSEMBLY, INSTALLATION, AND REMOVAL OF ALL HANGING SIGNS/TRUSSES THAT DO NOT REQUIRE A CHAIN MOTOR.

- A crew will be assigned consisting of a lift with two riggers for aerial work.
- If your sign requires a chain motor, please contact AV Concepts at 602.252.2425

Important Information & Rates

Starting time can be guaranteed only when labor is requested for the start of the working day at 8:00 AM. All exhibit labor for 8:00 AM starting times will be dispatched to booth space. Confirm labor and equipment by 2:30 PM the day before date requested. For rigging work starting at times other than 8:00 AM, please have a representative pick up the crew at the labor desk and supervise the work to be done. Upon completion, the Exhibitor's representative will return the crew to the labor desk and approve the work order. Equipment and labor cancelled without a 24 hour notice shall be charged a one (1) hour cancellation fee per worker and equipment. If Exhibitor fails to use the workers and equipment at the time confirmed, a one (1) hour "Not Ready" charge per worker and equipment will apply.

The minimum charge for labor is one (1) hour per worker and equipment. Labor thereafter is charged in half (½) hour increments per worker and equipment. Gratuities in any form, including cash, gifts, or labor hours for work not actually performed are prohibited by GES. GES requires the highest standards of integrity from all employees. Please call our confidential Always Honest hotline at 866.225.8230 to report fraudulent or unethical behavior. All rates are subject to change if necessitated by increased labor and material costs.

LABOR RATES ARE AS FOLLOWS:

High Lift w/Crew	Discount	Regular	Show Site
High Lift, ST Code: 705300	\$ 410.00	\$ 513.00	\$ 615.00
High Lift, OT Code: 705300	\$ 513.00	\$ 641.00	\$ 770.00
High Lift, DT Code: 705300	\$ 770.00	\$ 963.00	\$ 1,160.00

Worker per Hour	Discount	Regular	Show Site
Rigging, Hanging Sign, ST Code: 705020	\$ 94.50	\$ 118.00	\$ 142.00
Rigging, Hanging Sign, OT Code: 705020	\$ 142.00	\$ 178.00	\$ 213.00
Rigging, Hanging Sign, DT Code: 705020	\$ 284.00	\$ 355.00	\$ 426.00

Straight Time: Monday through Friday from 8:00 AM to 4:30 PM.
Overtime: All other times Monday through Friday. All day Saturday & Sunday.
Double Time: All day Holidays.
Discount Rate: Rate applies to orders placed on or before the above Discount Deadline Date.
Regular Rate: Rate applies to orders placed after the above Discount Deadline Date, but before the first day of exhibitor move-in.
Show Site Rate: Rate applies to orders placed at show site

Please Indicate Service

- GES Supervised (OK to Proceed)**
 A 25% (\$50.00 minimum) surcharge will be added to the labor rates above for this professional supervision.
- Exhibitor Supervised (Do Not Proceed)**
 Exhibitor will supervise.
- Indicate workers needed for installation **and** dismantling.
 - GES assumes no liability for loss, damage or bodily injury arising out of the installation and/or dismantling of Exhibitor's property by GES provided union labor. Exhibitor assumes the responsibility and any liability arising therefrom, for the work performed by union labor under Exhibitor's supervision. Exhibitors must stay clear during movement of freight.

Type of Sign (Select one sign type per order)

Banner Structural Signage Systems

Shape of Sign (Select one sign type per order)

Square Rectangle Triangle

Circle Other _____

Dimensions & Weight of Sign

Width _____ Length _____ Height _____ Weight _____ lbs

_____ Structural Pick Points: # of Pounds _____ at each point

Number of Feet from Floor to Top of Sign (Must be compliant with Show Rules & Regulations _____ Feet)

Is Your Sign Electrical? If yes, order power requirements on the Electrical Services Order Form in this manual.

Yes No

Does Your Sign Require Assembly? If yes, GES will assemble your sign prior to hanging. See Hanging Sign/Truss Information.

Yes No

Include engineer-stamped assembly and hanging instructions with the order. GES accepts no liability for any work completed without such instructions, when required. Work is done at Exhibitor's risk and Exhibitor shall indemnify and defend GES and Show Organizer from any claims and/or bodily injuries arising out of or related to the installation or dismantle of any sign without approved drawings.

LOCATION OF SIGN / DIMENSION OF TRUSS: Use the H-3: Booth Layout Form to represent your booth and indicate from each boundary how you would like your sign/truss placed.

Place Order Here

SCHEDULE DATE(S)	SCHEDULE START TIME	SCHEDULE END TIME	TOTAL # OF HOURS	TOTAL # OF LIFT W/ CREW	LABOR RATE	TOTAL	3% PSP	GRAND TOTAL
	AM PM	AM PM						\$
	AM PM	AM PM						\$

I agree in placing this order that I have accepted GES Payment Policy and GES Terms & Conditions of Contract.

Authorized Signature - Please Sign:

X	AUTHORIZED NAME - PLEASE PRINT	DATE
---	--------------------------------	------

A.	Total Labor Ordered	\$
B.	25% (\$50.00) GES Supervision	\$
C.	Payment Enclosed	\$

Please estimate the number of workers and hours per worker needed for installation and dismantling above. Invoice will be calculated according to actual hours worked, relative to the original estimate and based upon the date received. Additional labor required will be calculated and invoiced at the show site rate.

Need Assistance?

Toll Free: 800.475.2098 | Tel: 702.515.5970 | www.ges.com/chat

Order Directly Online:
<https://e.ges.com/017600137/esm>

USE THESE SHIPPING LABELS AS THEY WILL EXPEDITE HANDLING. Copies of these labels are acceptable if additional labels are needed.
See form H-1a: Hanging Sign Shipping Labels when shipping Hanging Signs.

H-1a



FROM:



FROM:

ADVANCE SHIPMENT

TO:

FULL EXHIBITING COMPANY NAME AT SHOW

2013 Big O Tires Convention

NAME OF EXHIBITION

0170600137

Booth Number

C/O GES
1740 South 40th Avenue
Phoenix, AZ 85009
USA

SHIPMENT SHOULD ARRIVE ON OR BETWEEN:

Wednesday, March 20, 2013 - Wednesday, April 17, 2013

CERTIFIED WEIGHT TICKETS ARE REQUIRED FOR ALL SHIPMENTS. Drivers must check in by 2:00 PM to be guaranteed same day unloading. Warehouse receiving hours are Monday - Friday, 8:00 AM - 4:30 PM; Closed 12:00 PM - 1:00 PM & Holidays.

Carrier _____
Number _____ of _____ pieces



ADVANCE SHIPMENT

TO:

FULL EXHIBITING COMPANY NAME AT SHOW

2013 Big O Tires Convention

NAME OF EXHIBITION

0170600137

Booth Number

C/O GES
1740 South 40th Avenue
Phoenix, AZ 85009
USA

SHIPMENT SHOULD ARRIVE ON OR BETWEEN:

Wednesday, March 20, 2013 - Wednesday, April 17, 2013

CERTIFIED WEIGHT TICKETS ARE REQUIRED FOR ALL SHIPMENTS. Drivers must check in by 2:00 PM to be guaranteed same day unloading. Warehouse receiving hours are Monday - Friday, 8:00 AM - 4:30 PM; Closed 12:00 PM - 1:00 PM & Holidays.

Carrier _____
Number _____ of _____ pieces



RETURN TO: Global Experience Specialists, Inc. (GES) • 7000 Lindell Road, Las Vegas, NV 89118-4702 • Fax: 866.329.1437 or 702.263.1520 for international exhibitors
 Contact us Online: www.ges.com/chat Phone: 800.475.2098 or 702.515.5970 for international exhibitors

All orders are governed by the GES Payment Policy and GES Terms & Conditions of Contract as specified in this Exhibitor Services Manual.

2013 Big O Tires Convention
 Phoenix Convention Center
 April 23, 2013

Form Deadline Date:
 April 1, 2013

COMPANY NAME	EMAIL ADDRESS	BOOTH NUMBER
--------------	---------------	--------------

At your request, Global Experience Specialists, Inc. (GES) (“GES”), as the exclusive provider of sign hanging and rigging services at the 2013 Big O Tires Convention (“Show”), April 23, 2013 (“Dates”), will hang your company’s or organization’s materials (banners, signs, lights, or rigging supplies). However, because your company or organization has elected to use non-GES materials and because of the inherent hazards associated with these services, GES needs your company or organization to indemnify GES and release them from any liability resulting from these services. By signing, your company or organization is guaranteeing the stress points are properly engineered for hanging the sign(s). However, GES may refuse to hang a sign, if, in our opinion it appears unsafe. In exchange for the services described above,

_____ (“Company/Organization”) hereby agrees to hold harmless, defend and indemnify GES, its officers, directors, employees, agents and subcontractors from and against any and all claims, liability, losses, costs and expenses, including reasonable attorneys’ fees, resulting directly or indirectly from the performance by GES of such hanging and rigging services.

Except as expressly stated herein, the contract between the parties for the above-referenced Show remains in full force and effect.

GES _____ Signature _____ Print Name _____ Date	Company/Organization _____ Signature _____ Print Name _____ Date
---	--

**IF YOUR SIGN REQUIRES A CHAIN MOTOR,
 PLEASE CONTACT AV CONCEPTS AT 602-252-2425**

RETURN WITH G-2: PAYMENT & CREDIT CARD CHARGE AUTHORIZATION FORM TO:

Global Experience Specialists, Inc. (GES) • 7000 Lindell Road, Las Vegas, NV 89118-4702 • Fax: 866.329.1437 or 702.263.1520 for international exhibitors

All orders are governed by the GES Payment Policy and GES Terms & Conditions of Contract as specified in this Exhibitor Services Manual.

2013 Big O Tires Convention
 Phoenix Convention Center
 April 23, 2013

Discount Deadline Date:
 April 1, 2013

COMPANY NAME	EMAIL ADDRESS	BOOTH NUMBER
--------------	---------------	--------------

Price List

ITEM#	DESCRIPTION	DISCOUNT PRICE	REGULAR PRICE
Vacuuming			
<i>Includes emptying your wastebasket nightly.</i>			
500601	Before Show Open Only (per sq. ft.)	\$ 0.54	\$ 0.81
500600	Duration of Show (per sq. ft. per day)	\$ 0.38	\$ 0.57
500602	Per Day (per sq. ft. per day)	\$ 0.49	\$ 0.74
Shampooing			
501004	Cleaning, Carpet Shampoo Before Show Open	\$ 0.67	\$ 1.01
Mopping and Waxing			
501002	Cleaning, Damp Mop & Wax	\$ 0.89	\$ 1.34
Porter service			
<i>GES will empty wastebaskets & wipe down counters at two hour intervals, show hours only. Vacuuming not included. Calculate by your booth size.</i>			
501010	Porter Service, 0-500 sq.ft., Per Day	\$ 84.75	\$ 127.00
501010	Porter Service, 501-1500 sq.ft., Per Day	\$ 170.00	\$ 255.00
501010	Porter Service, 1501-3000 sq.ft., Per Day	\$ 329.00	\$ 494.00
501010	Porter Service, 3001 sq.ft. & Up, Per Day	\$ 405.00	\$ 608.00

To ensure your booth is show-ready, specify your requirements below. Please call us if you have a special need. GES is the exclusive cleaning contractor for your show and will handle all cleaning services on the exhibit floor. We offer discounts for orders exceeding 2,000 square feet (please call for a quote).

Cost of vacuuming, shampooing, mopping and waxing will be invoiced on the total area of your booth.

Cancellation Policy: Due to material and labor costs, orders cancelled before move-in begins will be charged **50%** of original price. Similarly, orders cancelled after move-in will be charged **100%**.

LABOR RATES ARE AS FOLLOWS:

Worker per Hour	Discount	Regular	Show Site
Porter Service, ST Code: 705010	\$ 91.00	\$ 110.00	\$ 132.00
Porter Service, OT Code: 705010	\$ 137.00	\$ 165.00	\$ 198.00
Porter Service, DT Code: 705010	\$ 182.00	\$ 220.00	\$ 264.00

Use for booth wipedown, ice removal, etc. Hourly rates are listed above. The minimum charge for labor is four (4) hours per worker per day. Labor thereafter is charged in half (1/2) hour increments.

Straight Time: Monday through Friday from 8:00 AM to 4:30 PM.

Overtime: All other times Monday through Friday. All day Saturday & Sunday.

Double Time: All day Holidays.

Discount Rate: Rate applies to orders placed on or before the above Discount Deadline Date.

Regular Rate: Rate applies to orders placed after the above Discount Deadline Date, but before the first day of exhibitor move-in.

Show Site Rate: Rate applies to orders placed at show site.

Please Indicate Service

Calculate Total Square Footage

Width _____ x Length _____ = _____ Square Feet

Would you like us to call you and give you a quote for hourly porter service?

Yes No

Please list dates and times Vacuuming Per Day/Periodic Porter Service is needed:

To avoid any misunderstanding regarding these services, please bring any discrepancies to our attention at the **GES Servicenter**. GES will be unable to adjust invoices after the close of the show.

Place Order Here

ITEM#	DESCRIPTION	TOTAL SQ FT	X PRICE/SQ FT	X NO. OF DAYS	= TOTAL PRICE
500600	Vacuuming Duration			1	\$
500602	Vacuuming Per Day				\$

ITEM#	DESCRIPTION	TOTAL SQ FT	X PRICE/SQ FT	= TOTAL PRICE
500601	Vacuuming Before Show Only			\$
501004	Shampooing Before Show Only			\$
501002	Mop/Wax Before Show Only			\$

ITEM#	DESCRIPTION	PRICE	X NO. OF DAYS	= TOTAL PRICE
	Porter service			\$

DESCRIPTION	TOTAL # OF HOURS	X	TOTAL # OF WORKERS	X	LABOR RATE	= TOTAL PRICE
Porter Service Labor						\$

A.	Total All Items Ordered	\$
B.	Petroleum Surcharge Assessment: 3%	A x 3% = B \$
C.	Payment Enclosed	A + B = C \$

I agree in placing this order that I have accepted GES Payment Policy and GES Terms & Conditions of Contract.

Authorized Signature - Please Sign: _____ X

AUTHORIZED NAME - PLEASE PRINT	DATE
--------------------------------	------



Credit Card Authorization: Global Experience Specialists, Inc. (GES) • 7000 Lindell Road, Las Vegas, NV 89118-4702 • Fax: 866.329.1437 or 702.263.1520 for international exhibitors

Check Payments: Global Experience Specialists, Inc. (GES) • Bank of America P.O. Box 96174, Chicago, IL 60693

All orders are governed by the GES Payment Policy and GES Terms & Conditions of Contract as specified in this Exhibitor Services Manual.

2013 Big O Tires Convention
 Phoenix Convention Center
 April 23, 2013

Form Deadline Date:
 April 1, 2013

MANDATORY FORM*

COMPANY NAME	EMAIL ADDRESS	BOOTH NUMBER		
STREET ADDRESS	CITY	STATE	ZIP	COUNTRY
PHONE	FAX	PURCHASE ORDER NUMBER		
BOOTH PRIMARY CONTACT NAME AND PHONE NUMBER		SHOWSITE CONTACT NAME AND PHONE NUMBER		

Payment Policy

Payment for Services — GES requires payment in full at the time services are ordered. Further, GES requires that you provide a credit card authorization with your initial order. For your convenience, we will use this authorization to charge your account for services, which may include labor, material handling, or any applicable fuel or energy surcharge.
Discount Prices — To qualify for discount pricing, orders must be received with payment on or before the discount price deadline(s).
Method of Payment — GES accepts MasterCard, Visa, American Express, check and bank wire transfer. Purchase orders are not considered payment. All payments must be made in U.S. funds drawn on a U.S. Bank. *Exhibitors will be charged a \$50.00 fee for returned NSF checks.*
Third Party Billing — Each exhibiting firm is ultimately responsible for all charges incurred on its behalf. GES reserves the right to institute collection action against the exhibitor if the authorized third party does not pay. See *Third Party Billing Request* form.
Tax Exempt — If you are tax exempt in the state in which you will be exhibiting, you must provide a Sales Tax Exemption Certificate for that state. Please send the above information to the GES office for this show. Taxes vary by location and will be added to your invoice, if you do not submit your tax exempt certificate prior to the deadline.
Adjustments and Cancellations — No adjustments to invoices will be made after the close of the show. Please refer to the individual forms for labor, etc., for cancellation fees. All orders cancelled by the Exhibitor or due to the cancellation of an event or their non-participation may be subject to cancellation fees equal to 50% - 100% of the total order, based upon the status of move-in, work performed and/or GES set-up costs or expenses. A minimum non-refundable deposit of \$25.00 will be applied towards the invoice, unless there is a cancellation of your order. Additionally, GES retains the right to implement/ assess a fuel or energy surcharge on all services as necessary based upon market conditions.
Bank wire transfer payment information:

Beneficiary: Global Experience Specialists
 c/o Bank of America **Account #:** 7188-1-01819
 901 Main Street, TX1-492-07-14 **ABA Routing #:** 0260-0959-3
 Dallas, TX 75202-3714 USA **SWIFT Address:** BOFAUS3N
 Telephone # 888-715-1000 ext 50118 **CHIPS Address:** 0959

If requested, following is the physical address for routing identifiers:
 Bank of America, Wire Transfer-Customer Services
 2000 Clayton Road, Concord, CA 94520 USA

To properly credit your account, send the following information to the GES address listed on the order forms:

- exhibiting company name, show name, show facility, and booth number
- date and amount of wire transfer
- bank and country where transfer originated

- If you have any questions regarding our payment policy, please call GES National Servicer[®] at 800.475.2098 or visit the GES Servicer[®] at the show.
- Please complete the information and return payment in full with this form and your orders. You may choose to pay by credit card, check, or bank wire transfer, however, we require your credit card charge authorization to be on file with GES.
- All balances must be paid at the conclusion of the event. You agree to late fees up to 1.5% per month on any balance not paid at the conclusion of the event, or balance left without appropriate credit card on file.
- For your convenience, we will use this authorization to charge your credit card for any additional amounts ordered by your representative or services rendered to your company for this event.
- GES will charge a convenience fee for each request to reprocess payment to an alternate credit card in order to cover incremental processing costs. An alternate credit card is a credit card different than the one used to process your initial payment in accordance with GES payment policy. The convenience fee will be quoted at the time your request is made to reprocess payment. The convenience fee will be added to your account balance and settled utilizing the new credit card provided.

GES requires the highest standards of integrity from all employees. Please call our confidential Always Honest hotline at 866.225.8230 to report fraudulent or unethical behavior.

***This form must be returned to GES for your orders to be processed.**

Credit Card Charge Authorization

All information must be provided. **Your order will not be processed if any information is missing.** (i.e., Expiration Date, Account Number, Contact Information, Type of Card, Signature) **We require your credit card charge authorization to be on file with GES even if you are paying by check or bank wire transfer.**

Account Number Corporate Card Personal Card

_____ - _____ - _____ - _____

PROVIDE EXPIRATION DATE **EXPIRATION DATE** MasterCard VISA American Express

*Signature Required Below

CARDHOLDER'S NAME PLEASE PRINT _____

CARDHOLDER'S BILLING ADDRESS CITY _____

STATE ZIP COUNTRY _____

Calculation of Orders **TOTAL**

Material Handling	\$
Carpet	\$
Furniture & Accessories	\$
Specialty Furniture	\$
Standard Exhibit Systems	\$
Graphics & Signage	\$
Installation & Dismantling Labor	\$
In-Booth Forklift & Labor	\$
Hanging Sign Labor	\$
Cleaning	\$
Other GES Services (Specify)	\$
Other GES Services (Specify)	\$
FULL PAYMENT in U.S. funds drawn on a U.S. Bank <small>Global Experience Specialists Federal ID #59-1008863 GES is exempt from backup withholding tax.</small>	\$

To simplify payment, send a check payable to Global Experience Specialists for your entire order or note the amount to be charged to your credit card.

Charge my credit card in the amount of: \$ _____

Enclosed is a check in the amount of: \$ _____

Check Number: _____ Dated: _____

Please note payment return addresses at top of form.

I agree in placing this order that I have accepted GES Payment Policy and GES Terms & Conditions of Contract. *Credit card charge authorization signature required below.

PLEASE SIGN X _____

AUTHORIZED SIGNATURE / CARDHOLDER'S SIGNATURE

_____ AUTHORIZED NAME - PLEASE PRINT _____ DATE

Need Assistance?

Toll Free: 800.475.2098 | Tel: 702.515.5970 | www.ges.com/chat

RETURN TO: Global Experience Specialists, Inc. (GES) • 7000 Lindell Road, Las Vegas, NV 89118-4702 • Fax: 866.329.1437 or 702.263.1520 for international exhibitors
 Contact us Online: www.ges.com/chat Phone: 800.475.2098 or 702.515.5970 for international exhibitors

All orders are governed by the GES Payment Policy and GES Terms & Conditions of Contract as specified in this Exhibitor Services Manual.

2013 Big O Tires Convention
 Phoenix Convention Center
 April 23, 2013

Form Deadline Date:
 April 1, 2013

COMPANY NAME	EMAIL ADDRESS	BOOTH NUMBER
--------------	---------------	--------------

If you would like to arrange a third party to handle your display, please complete the below steps:

- **Step 1:** Fill in the appropriate information and select the services to be charged to the **Exhibiting Firm**. A signature is **required** to authorize these services.
- **Step 2:** Complete and sign the **Exhibiting Firm** Credit Card Authorization.
- **Step 3:** Fill in the appropriate information and select the services to be charged to the **Third Party**. A signature is **required** to authorize these services.
- **Step 4:** Complete and sign the **Third Party** Credit Card Authorization.

GES reserves the right to deny any Third Party Billing Request that is not complete or received by the deadline date.

It is understood and agreed that the exhibiting firm is ultimately responsible for payment of charges. If your named third party does not pay the invoice before the last day of the show, charges will revert to the exhibiting firm. All invoices are due and payable upon receipt. GES Terms & Conditions of Contract apply to both the Exhibiting Firm and Third Party Representative.

STEP 1: Exhibiting Firm - Complete Below Information	STEP 2: Exhibiting Firm Credit Card Charge Authorization
EXHIBITING FIRM	CARDHOLDER'S NAME PLEASE PRINT
STREET ADDRESS	CARDHOLDER'S BILLING ADDRESS CITY
CITY STATE ZIP	STATE ZIP COUNTRY
PHONE FAX	
<p><i>The items checked below are to be invoiced to the Exhibiting Firm:</i></p> <input type="checkbox"/> Booth Cleaning <input type="checkbox"/> Exhibit Systems <input type="checkbox"/> I & D Labor <input type="checkbox"/> In-Booth Forklift Labor <input type="checkbox"/> Material Handling In & Out <input type="checkbox"/> Rental Carpet <input type="checkbox"/> Rental Furniture <input type="checkbox"/> Signs <input type="checkbox"/> Transportation Charges <input type="checkbox"/> Other (Please Specify) _____	<p>Account Number</p> <div style="border: 1px solid black; padding: 2px; display: flex; justify-content: space-between;"> - - - </div> <p>EXPIRATION DATE <input type="checkbox"/> MasterCard <input type="checkbox"/> Corporate Card <input type="checkbox"/> VISA <input type="checkbox"/> Personal Card <input type="checkbox"/> American Express</p>
<p>I agree in placing this order that I am responsible for the above selected services and that I have accepted GES Payment Policy and GES Terms & Conditions of Contract.</p> <p>PLEASE SIGN X</p> <p>_____ AUTHORIZED SIGNATURE</p> <p>_____ AUTHORIZED NAME - PLEASE PRINT</p> <p>_____ DATE</p>	<p>All information must be provided. Your order will not be processed if any information is missing. (i.e. Expiration Date, Account Number, Contact Information, Type of Card, and Signature.) We require your credit card charge authorization to be on file with GES even if you are paying by check or bank wire transfer.</p> <p>PLEASE SIGN X</p> <p>_____ CARDHOLDER'S SIGNATURE</p> <p>_____ CARDHOLDER NAME - PLEASE PRINT</p> <p>_____ DATE</p>

Check here if the Third Party or its sub-contractors will be providing services to Exhibiting Firm at show site. (EAC Notification Form and insurance requirements must be completed for admission)

STEP 3: Third Party - Complete Below Information	STEP 4: Third Party Credit Card Charge Authorization
THIRD PARTY	CARDHOLDER'S NAME PLEASE PRINT
STREET ADDRESS	CARDHOLDER'S BILLING ADDRESS CITY
CITY STATE ZIP	STATE ZIP COUNTRY
PHONE FAX	
<p><i>The items checked below are to be invoiced to the Third Party:</i></p> <input type="checkbox"/> Booth Cleaning <input type="checkbox"/> Exhibit Systems <input type="checkbox"/> I & D Labor <input type="checkbox"/> In-Booth Forklift Labor <input type="checkbox"/> Material Handling In & Out <input type="checkbox"/> Rental Carpet <input type="checkbox"/> Rental Furniture <input type="checkbox"/> Signs <input type="checkbox"/> Transportation Charges <input type="checkbox"/> All Services <input type="checkbox"/> Other (Please Specify) _____	<p>Account Number</p> <div style="border: 1px solid black; padding: 2px; display: flex; justify-content: space-between;"> - - - </div> <p>EXPIRATION DATE <input type="checkbox"/> MasterCard <input type="checkbox"/> Corporate Card <input type="checkbox"/> VISA <input type="checkbox"/> Personal Card <input type="checkbox"/> American Express</p>
<p>I agree in placing this order that I am responsible for the above selected services and that I have accepted GES Payment Policy, GES Terms & Conditions of Contract, and Agreement and Rules and Regulations between GES and EAC (L4).</p> <p>PLEASE SIGN X</p> <p>_____ AUTHORIZED SIGNATURE</p> <p>_____ AUTHORIZED NAME - PLEASE PRINT</p> <p>_____ DATE</p>	<p>All information must be provided. Your order will not be processed if any information is missing. (i.e. Expiration Date, Account Number, Contact Information, Type of Card, and Signature.) We require your credit card charge authorization to be on file with GES even if you are paying by check or bank wire transfer.</p> <p>PLEASE SIGN X</p> <p>_____ CARDHOLDER'S SIGNATURE</p> <p>_____ CARDHOLDER NAME - PLEASE PRINT</p> <p>_____ DATE</p>

Need Assistance?

Toll Free: 800.475.2098 | Tel: 702.515.5970 | www.ges.com/chat



Order Directly Online:
<https://e.ges.com/017600137/esm>

017600137

RETURN TO: Global Experience Specialists, Inc. (GES) • 7000 Lindell Road, Las Vegas, NV 89118-4702 • Fax: 866.329.1437 or 702.263.1520 for international exhibitors
 Contact us Online: www.ges.com/chat Phone: 800.475.2098 or 702.515.5970 for international exhibitors

All orders are governed by the GES Payment Policy and GES Terms & Conditions of Contract as specified in this Exhibitor Services Manual.

2013 Big O Tires Convention
 Phoenix Convention Center
 April 23, 2013

Form Deadline Date:
 April 1, 2013

MANDATORY FORM*

COMPANY NAME		EMAIL ADDRESS	BOOTH NUMBER	
SHOWSITE CONTACT		SHOWSITE CONTACT PHONE #	DATE/TIME OF ARRIVAL	CONTACT'S HOTEL (OPTIONAL)

A unique grid must be completed for each of the following services to ensure proper placement of items in your booth. Please do not combine services onto a single grid. Print/photocopy as needed.

- Hanging Signs/Truss - Form H-2
- Show Cases - Form A-1
- Pegboard / Tackboard - Form A-1
- Special Colored Drape - Form A-1
- Standard Exhibit Systems (if exhibit size is smaller than booth size) - Form D-1
- Pad and Carpet (if you are not carpeting your entire booth) - Form C-1
- Installation & Dismantling - Form L-1

To use this grid:

- Use bold lines to indicate the outline of your booth.
- Indicate the scale of the grid (i.e. 1 square = 1 foot) or indicate the dimensions of your booth.
- Mark the adjacent booth numbers or aisle numbers.

Each square is _____ feet square since my booth is _____ feet wide by _____ feet long.

BACK OF BOOTH (indicate adjacent booth or aisle number: _____)

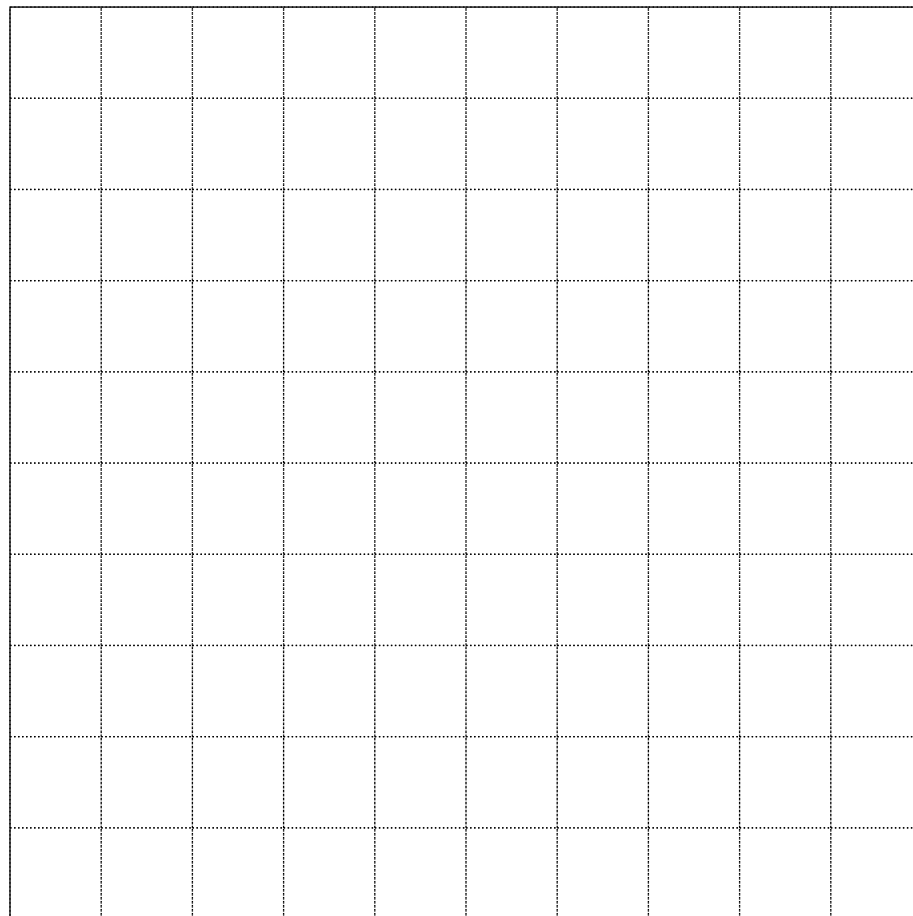

Indicate
 Adjacent
 Booth or
 Aisle Number:

Indicate
 Adjacent
 Booth or
 Aisle Number:

FRONT OF BOOTH (indicate adjacent booth or aisle number: _____)

***This form must be returned to GES for your orders to be processed.**



Additional Service Order Forms

see.hear.feel.



SouthWest AudioVisual
Equipment Request Form

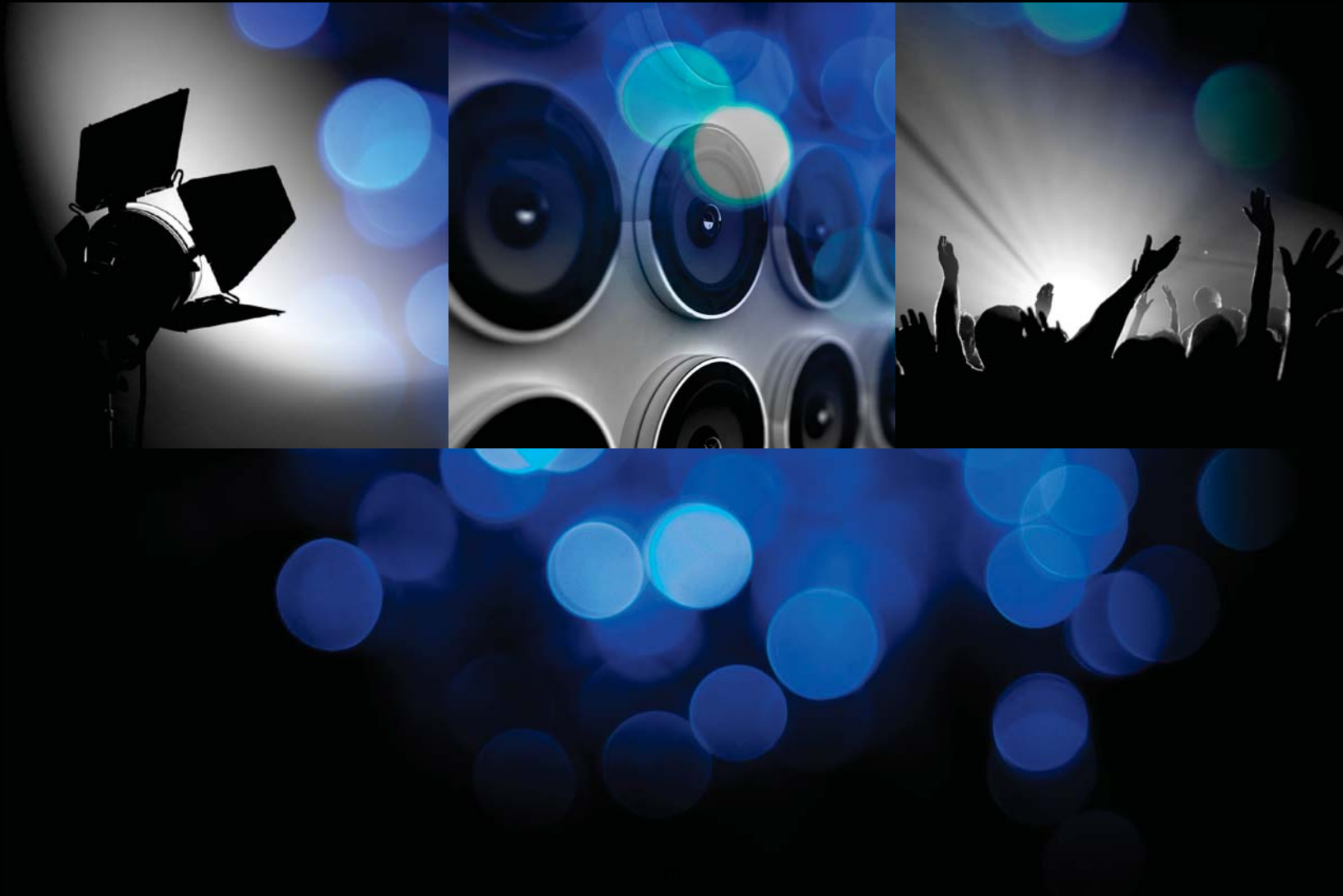

Hey, before you start...

Did you know you can request equipment from us in 3 different ways? Check it out:



Do it Online

Forget this PDF business and do the whole thing through our online form.

[Go Online](#)

OR



Fill & Email

Complete the fields in this PDF, save it, and email it back to us.

Acrobat Reader 10.0 Required

[Let's Do This](#)

OR



Print & Fax

Print the last page of this PDF, fill it out by hand, and fax it back to us.

[Print It](#)

The Way We Do Stuff



ORDERING: You will receive notification confirming your order within two business days. If you do not receive notification of receipt, please call our office. Orders must be received 14 days in advance of show date to insure availability.



PRICING: Prices are based on a "per day" usage with a 3 day maximum charge for shows up to 5 days. Setup days with NO equipment usage will NOT be charged. There is a \$90.00 service fee which includes the delivery and pick-up of equipment. Any additional labor required must be specified in advance and will be quoted accordingly.



PAYMENT: All orders must have 100% of estimated charges plus sales tax remitted with order. We use PayPal for processing payments.



CANCELLATIONS: Cancellation of equipment ordered must be received 48 hours prior to delivery date to avoid charges. If services have already been provided at the time of cancellation, 50% of original charges will be applied with a minimum charge of one full day.

Event Details

Event name

Event location

Start date (mm/dd/yyyy) End date (mm/dd/yyyy)

Booth #

On site contact

Contact's cell #

Contact Information

Name

Email

Phone

Fax

Company

Address

City

State/Province

Zip/Postal Code

Country

Equipment Needed

Video Monitors

	QTY	TOTAL
20" LCD (for computer use only)	<input type="text"/>	<input type="text"/>
32" LCD	<input type="text"/>	<input type="text"/>
42" Plasma <input type="radio"/> On feet <input type="radio"/> With stand	<input type="text"/>	<input type="text"/>
50" Plasma <input type="radio"/> On feet <input type="radio"/> With stand	<input type="text"/>	<input type="text"/>

Video Players

	QTY	TOTAL
Standard DVD	<input type="text"/>	<input type="text"/>
Blu-Ray DVD	<input type="text"/>	<input type="text"/>

Data Projectors

	QTY	TOTAL
4500 lumens	<input type="text"/>	<input type="text"/>
2300 lumens	<input type="text"/>	<input type="text"/>

Screens & Accessories

	QTY	TOTAL
6 ft tripod with skirt	<input type="text"/>	<input type="text"/>
8 ft tripod with skirt	<input type="text"/>	<input type="text"/>
Cart with skirt <input type="radio"/> 34" <input type="radio"/> 42" <input type="radio"/> 54"	<input type="text"/>	<input type="text"/>
Flipchart with paper and markers	<input type="text"/>	<input type="text"/>

Computers (Includes Windows 7, Microsoft Office 2010, Adobe Acrobat Reader)

	QTY	TOTAL
Desktop Intel Quad Core with keyboard, mouse, and speakers	<input type="text"/>	<input type="text"/>
Laptop Intel Quad Core	<input type="text"/>	<input type="text"/>

Audio

	QTY	TOTAL
PA System w/ 1 speaker & wired mic	<input type="text"/>	<input type="text"/>
PA System w/ 2 speakers & wired mic	<input type="text"/>	<input type="text"/>
Wireless mic (for use with systems above) <input type="radio"/> Lavalier <input type="radio"/> Handheld	<input type="text"/>	<input type="text"/>
CD player (for use with systems above)	<input type="text"/>	<input type="text"/>

Prices are based on a per day usage with a **3 day maximum** charge for shows up to 5 days.

Sales tax only applies to events inside the state of Arizona.

There is a \$90.00 service fee on all orders which includes the delivery and pick-up of equipment.

Subtotal	<input type="text"/>
Day multiplier (max. 3)	<input type="text"/>
Equipment total	<input type="text"/>
9.3% sales tax	<input type="text"/>
Delivery/PU	<input type="text" value="90.00"/>

Total due \$

Don't see what you're looking for? This form is only a partial list of equipment featuring commonly requested items. We stock a full line of audio and video equipment. For items not found above, please ask about availability and prices.

Special Requests or Notes



SouthWest AudioVisual
 www.swav.net
 av@swav.net
 (602) 345-2125
 toll-Free (800) 266-SWAV
 fax (602) 254-4226

Rates Effective July 1, 2012-June 30th, 2013

Information & Online Ordering
www.commonwealthexpo.com



Phoenix Convention Center

Electrical Order Form Mail or Fax to:
Commonwealth Electric Company Exposition Service Division
 100 North 3rd St. Phoenix, AZ 85004
PH: (602)253.5881 Fax: (602)253.5530
 Email Address: expo@commonwealthelectric.com

Event: 2013 Big O Tires Convention					Dates: April 23, 2013	
For Discount Payment Price we must receive your order and payment prior to this					Event #: 478609	
DISCOUNT DEADLINE DATE OF:					04.09.13	
Company Name:					Booth #	
STANDARD ELECTRICAL DROPS						
Quantity	Description	Discount	Regular	Amount	If you require services not listed on this form please call for a quote. Lighting, Water and/or Air: Please call for Order Form 24 Hour Services: Rates are DOUBLE the Outlet Rate _____ Check if required. Overhead Power: Rates are Time and Material, please call for quote. 208V and 480V Services: There is a MINIMUM labor charge of (1) hr. for installation/removal of all 208V service. There is a MINIMUM labor charge of (2) hrs. for installation/removal of all 480V service. ELECTRICAL LABOR: Outlets requested to be placed anywhere other than the back of the booth will require a layout and a MINIMUM of (1) hour labor. Please call for quotes on labor if your booth is an Island booth or needs overhead power. _____ Okay to Proceed (layout with scaled orientation attached) Order will be installed prior to exhibitor move-in. _____ Exhibitor Supervision Requested-Requires a MINIMUM of 1 Hr of Labor. Please indicate the following Date and Time Requested: _____ / _____ / _____ am/pm Onsite Contact Name: _____ Onsite Contact Cell # _____	
Standard Outlet 120V A.C. 60 Cycle						
	500 Watts	\$99.75	\$129.68			
	1000 Watts	\$135.00	\$175.50			
	2000 Watts	\$176.00	\$228.80			
Single Phase 208V A.C. 60 Cycle Requires MINIMUM (1) hr Labor						
	10 Amp	\$229.95	\$298.94			
	20 Amp	\$271.95	\$353.54			
	30 Amp	\$338.10	\$439.53			
	50 Amp	\$460.95	\$599.24			
	60 Amp	\$522.90	\$679.77			
	100 Amp	\$868.35	\$1,128.86			
Three Phase 208V A.C. 60 Cycle Requires MINIMUM (1) hr Labor						
	10 Amp	\$260.40	\$338.52			
	20 Amp	\$373.80	\$485.94			
	30 Amp	\$426.30	\$554.19			
	50 Amp	\$622.65	\$809.45			
	60 Amp	\$723.45	\$940.49			
	100 Amp	\$1,331.40	\$1,730.82			
Rental Items						
	Extension Cord 15'	\$28.35				
	Extension Cord 25'	\$30.45				
	5-way power strip	\$26.25				
	3-way adaptor	\$23.10				
Labor						
	ST (M-F 8am-4:30pm)	\$92.40				
	OT (M-F 4:30pm-12am & Sat 8am-12 am)	\$138.60				
	DT (M-F 12Am-8am & all Sundays/Holidays)	\$184.80				
State of Arizona or Federal Tax Exempt form must be submitted with order to receive exemption.		Total Order				
		9.3% Sales Tax				
		Labor Amount				
By signing the order form, I have read and agree to all of Commonwealth Electric Company's Conditions and Regulations.		Total Due				
Company Name						
Address						
Email Address						
Signature						
Paid by: CK AX MC VS						
Cardholder Signature						
Phone		Fax				
City		State		Zip		
Onsite Contact:						
Print Name						
CC #		Exp Date:				



Commonwealth Electric Customer Information Phoenix Convention Center



Payment Policy:

Payment in Full is required on all outlets when order is placed. PURCHASE ORDERS are not considered payment. There will be an additional \$25.00 service charge on all returned checks.

Tax: All amounts, except labor, are subject to a combined Arizona State and City sales tax. If you are tax exempt in the STATE OF ARIZONA, please attach SALES TAX EXEMPTION CERTIFICATE to your order.

Discount Rates: available on orders **and** payments received ten (10) business days prior to show move-in. See the order form for exact date.

Regular Rates: are applied to all orders received AFTER the DEADLINE for DISCOUNT date and orders received on the show floor.

International: payment must be in US Dollars, money order, or credit cards.

Receipts and Confirmations: are available upon REQUEST.

Claims: will not be considered unless filed in writing by customer prior to close of show.

Credit: will not be given for outlets or equipment once they have been installed, regardless of usage.

Refunds: must be requested in writing by customer within 10 days of close of event.

Unpaid Balances: all balances must be paid prior to show open and any unpaid balances are subject to 1 ½ % thereafter.

Contract Agreement: Lessor will not be responsible for strikes accidents, fires, an Act of God, or delays beyond control. If by any reason of any default on the part of the lessee, hereunder, it becomes necessary to engage an attorney, the lessee agrees to pay all costs, expenses, and the attorney's fees expanded or incurred by lessor in connection therewith. Payment or receipt of this contract constitutes acknowledgment that exhibitor has read and agrees to all conditions and regulations as stated on this contract.

Outlets & Equipment:

Each outlet ordered is ONE SINGLE plug-in

Outlets will be located on the floor at the back of the booth or in the most convenient location for CECM. Exceptions include orders submitted with layouts-see layout section.

Outlets are provided at an ADDITIONAL charge and are not part of the booth package unless otherwise indicated on our CECM form.

Outlets are to be ordered separately by each exhibitor and may not be shared with other exhibitors.

Building utility outlets are not a part of the booth space and are not to be used by exhibitors unless specified otherwise.

Property: All materials and equipment furnished by CECM for this service order, shall remain the property of CECM and be removed only by CECM at the close of show. At the close of show, please leave all Commonwealth equipment in your booth to be collected.

Special: Exhibitors are responsible for supplying converters-220V to 120/110V-for international equipment. Exhibitors are responsible for GFI, if GFI is required. CECM can provide converters from 220V to 120/110V or GFI's at an additional charge.

Labor:

Requirements: You need to add a minimum of one hour labor to your order if...

You order 208V service or higher. A minimum of one hour of labor is required for EACH 208V connection. Please note your connector for each 208V service on the order form. See the Service Desk to request connect and disconnect.

Request your outlet anywhere but the back of the booth or send a layout for the location of your outlet.

Request exhibitor supervision for the placement of your electrical outlet.

Order an electrical outlet over 20amps 120V.

Request power to be dropped from the ceiling or located overhead.

Request eight (8) or more electrical outlets.

Installation:

CECM will not be responsible for any cutting or altering of any floor covering in order to bring power to a booth in a specific location.

See the Commonwealth Service desk for on-site assistance during exhibitor move-in to schedule 208V connect/disconnect.

Usage: Usually but can vary:

Up to 500 Watts:	TV, VCR, Radio, Expo Reader
Up to 2000 Watts:	Vacuum, hair dryers, heat lamps

Indicate BOOTH ORIENTATION on your layout.

Wattage/ampage is usually marked on the back or bottom of appliance or machine.

Total light bulb wattage to determine usage.

Conditions and Regulations:

All equipment, regardless of source of power, must comply with all federal, state and city safety codes.

All equipment must be properly tagged and wired with complete information as to type of current, voltage, phase, cycle, horsepower, etc.

All exhibitors' cords must be of the 3-wire grounded type. Use of open clip sockets, latex or lamp cord wire is prohibited. All exposed, non-current carrying metal parts of fixed equipment, which are liable to be energized, shall be grounded. All motors over 3HP must have magnetic starters and disconnecting switch furnished by the exhibitor.

Commonwealth Electric Company is not responsible for voltage fluctuations or power failure because of temporary conditions.

Rates Effective July 1, 2012-June 30th, 2013



Information & Online Ordering
www.commonwealthexpo.com



Phoenix Convention Center

Water/Air Order Form Mail or Fax to:
Commonwealth Electric Company Exposition Service Division
 100 North 3rd St. Phoenix, AZ 85004
PH: (602)253.5881 Fax: (602)253.5530
 Email Address: expo@commonwealthelectric.com

Event: 2013 Big O Tires Convention					Dates: April 23, 2013					
					Event #: 478609					
For Discount Payment Price we must receive your order and payment prior to this					04.08.13					
DISCOUNT DEADLINE DATE OF:										
Company Name:					Booth #					
Air/Water Service										
Quantity	Description	Discount	Regular	Amount	If you require services not listed on this form please call for a quote. Water Connection includes 3/4" hose thread, water, shutoff valve and drain hose with 3/4" standard thread. A detailed floor plan must be submitted with each Water and/or Air Order to ensure proper placement. A Representative must be in the booth or a fill line must be clearly marked before the fill can be completed.					
Compressed Air Service										
	1/4" Quick Connect Coupler	\$216.00	\$280.80							
	1/2" Quick Connect Coupler	\$216.00	\$280.80							
Water Fill (One Time Fill)										
	Up to 50 Gallons	\$93.00	\$120.90							
	51-500 Gallons	\$233.00	\$302.90							
	501-1000 Gallons	\$290.00	\$377.00							
	Additional Water-per 1000 Gallons (Over 1000 only)	\$226.00	\$293.80							
	Continuous Supply, Connect or Disconnect NOT included	\$221.00	\$287.30							
Do you need a drain? <input type="checkbox"/> Yes <input type="checkbox"/> No										
Please contact us for availability of potable water.										
Additional labor charge will apply for refills of water or if your water is requested to be turned on/off throughout the duration of the event. See rates below.										
Water Labor					Connect Date:					
ST (M-F 8am-4:30pm)		\$92.40			/ /	am/pm				
OT (M-F 4:30pm-12am & Sat 8am-12 am)		\$138.60								
DT (M-F 12Am-8am& all Sundays/Holidays)		\$184.80								
State of Arizona or Federal Tax Exempt form must be submitted with order to receive exemption.					Disconnect Date:					
					Total Order				/ /	am/pm
					9.3% Sales Tax					
Labor Amount										
By signing the order form, I have read and agree to all of Commonwealth Electric Company's Conditions and Regulations.		Total Due								
Company Name				Phone		Fax				
				X						
Address				City	State	Zip				
Email Address				Onsite Contact:						
Signature				Print Name						
Paid by: CK AX MC VS			CC #		Exp Date:					
Cardholder Signature				Print Name						



Commonwealth Electric Customer Information/Water and Air Service Phoenix Convention Center



Payment Policy:

Payment in Full is required on all outlets when order is placed. PURCHASE ORDERS are not considered payment. There will be an additional \$25.00 service charge on all returned checks.

Tax: All amounts, except labor, are subject to a combined Arizona State and City sales tax. If you are tax exempt in the STATE OF ARIZONA, please attach SALES TAX EXEMPTION CERTIFICATE to your order.

Discount Rates: available on orders and payments received ten (10) business days prior to show move-in. See the order form for exact date.

Regular Rates: are applied to all orders received AFTER the DEADLINE for DISCOUNT date and orders received on the show floor.

International: payment must be in US Dollars, money order, or credit cards.

Receipts and Confirmations: are available upon REQUEST.

Claims: will not be considered unless filed in writing by customer prior to close of show.

Credit: will not be given for outlets or equipment once they have been installed, regardless of usage.

Refunds: must be requested in writing by customer within 10 days of close of event.

Unpaid Balances: all balances must be paid prior to show open and any unpaid balances are subject to 1 ½ % thereafter.

Contract Agreement: Lessor will not be responsible for strikes accidents, fires, an Act of God, or delays beyond control. If by any reason of any default on the part of the lessee, hereunder, it becomes necessary to engage an attorney, the lessee agrees to pay all costs, expenses, and the attorney's fees expanded or incurred by lessor in connection therewith. Payment or receipt of this contract constitutes acknowledgment that exhibitor has read and agrees to all conditions and regulations as stated on this contract.

Connections & Equipment:

Customer is responsible for making the connection from water supply, air supply or drain to equipment.

If you would like Commonwealth to connect/disconnect your equipment – see Connect/Disconnect Labor.

All materials needed to make the connection are the exhibitor's responsibility.

Failure to make such a connection will result in additional labor charges according to CECM labor rates.

Connections are provided at an additional charge and are not part of the booth package unless otherwise indicated.

Connections are to be ordered separately by each exhibitor and may not be shared with other exhibitors.

Connection provided for compressed air is ½ inch or ¾ inch quick-connect coupler. Please contact us for any availability on any other size fitting.

Exhibitors are responsible for supplying converters-220V to 120/110V-for international equipment. Exhibitors are responsible for GFI, if GFI is required. CECM can provide converters from 220V to 120/110V or GFI's at an additional charge.

Property:

All materials and equipment furnished by CECM for this service order, shall remain the property of CECM and be removed only by CECM at the close of show. At the close of show, please leave all Commonwealth equipment in your booth to be collected

Connect/Disconnect Labor:

Requirements:

If you are requesting your water or air to be connected by Commonwealth Electric Co., you will be subject to the current labor rates.

Installation:

See the Commonwealth Service desk for on-site assistance during exhibitor move-in and to obtain receipts.

Special:

To help determine the amount of water needed for your fill, use the formula provided:

Length X Width X Height X 7.48=Number of Gallons.

Please call for quotes on labor if your booth is located outside.

An additional labor charge will apply if your water supply is requested to be turned on/off throughout the duration of the event.

Refills will be provided at an additional labor charge.

Filter systems for compressed air are available in limited access in the building.

Please mark the form if PORTABLE WATER is required.

Please specify if a drain will be required for your water fill.

A representative must be present in the booth or a fill line must be clearly marked before the water fill can be completed.

Layouts:

You must include a layout with your order to ensure proper placement...

Indicate booth orientation on your floor plan.

Conditions and Regulations:

All equipment must comply with all federal, state and city safety codes.

The customer must never hook-up or discontinue service without prior authorization from CECM.

The customer is never allowed to drain their own equipment of any water through the portholes in the floor of the exhibit hall, lobby or meeting rooms.

The customer will be responsible for any/all damages to the Phoenix Convention Center grounds, equipment or structure due to the customer's equipment, act or omissions.

Please call for information and quotes on services not described above.

Terms and Conditions / Payment Options

- | | |
|--|--|
| <ol style="list-style-type: none"> 1. Smart City is the exclusive provider and installer of all Voice, Data and Network services (wired and wireless) including communications cabling. This includes all cabling to meeting rooms, booths, within booths (under carpet and flooring), fiber optic, twisted pair (Category 3, 5 and 6), coaxial and all other data and telecommunications related cabling. 2. The use of the network connection(s) provided by Smart City may be used only by the directors, officers and employees of the Company, its guests, its agents and consultants while performing service for the Company and cannot be resold or distributed to other companies or individuals. 3. All devices for which Smart City directly or indirectly provides Internet / Network connectivity must pay a device charge or purchase a Smart City assigned IP address. 4. Incentive Price applies when a completed order with payment is received no later than 14 days prior to the first day of show move-in. Base Price applies to (a) all orders received from One (1) to Thirteen (13) days before show move-in has started or (b) orders received on or before the 14 day Incentive Deadline without payment (c) orders placed on site or after show move-in has started will be at Base Price plus an additional 20% X Base Price. 5. Internet / Network – 10 / 100 Mbps, full-duplex, auto-sensing, Ethernet access to our backbone, with shared or dedicated Internet access up to 128 Kbps or greater (depending on service ordered) via an RJ-45 jack, is provided for each connection ordered. 6. Shared Internet Services Specific: Routers, Streaming Applications, VoIP, DHCP, NAT or Proxy Servers are not allowed with any of our shared Internet / Network services. This includes, but is not limited to, NetPremium, NetStandard, NetBasic, and NetExpress. Smart City can engineer a custom dedicated network(s) to accommodate such special requests. Please call for quote. 7. Rates listed include a single IP address, standard installation to the booth in the most convenient manner and does not include computer equipment, NIC card, TCP / IP software or power to the booth. 8. Limited Availability: T-1 / DS-3 and other special circuit orders must be placed 45 days prior to show move-in date due to limited availability and to avoid additional charges. 9. Wireless Specific: (a) Smart City is the exclusive provider of voice, wired and wireless data service(s) for the Facility. Wireless Devices not authorized by Smart City are strictly prohibited. Customer(s) that desire to showcase their wireless products must contact Smart City 21 days in advance of show move-in to investigate the potential of Smart City engineering a customized cohesive network to operate without interference to other Customer(s), (applicable charges may apply). (b) The use of any wireless device that interferes with the facility's 2.4 / 5.8 GHz wireless data frequency range is prohibited and subject to disconnection at the Customer expense. 10. Unless otherwise directed, Smart City is authorized to cut floor coverings to permit installation of service. | <ol style="list-style-type: none"> 11. Internet Performance Disclaimer: Smart City does not guarantee the performance, routing, or throughput; either expressed or implied, of any data circuit(s) connectivity with regards to the Internet and / or Internet backbone(s) beyond the Facility. 12. Only Smart City personnel are authorized to modify system wiring or cabling. Material and equipment furnished by Smart City for this service contract shall remain the property of Smart City. 13. CANCELLATION – There is a minimum \$150 or 10% Cancellation fee (whichever is greater). Cancellations must be in writing. Additional cancellation charges will apply for orders that have already incurred processing, labor, material, and / or engineering costs. Some broadband services and special circuits cannot be cancelled once ordered and will incur full charges listed / quoted. Credit will not be given for service(s) installed and not used. 14. Service problems must be reported to the Smart City Service Desk. Service claims will not be considered unless filed in writing by Customer prior to close of show. 15. Any additional cost incurred by SMART CITY to: 1) assist in trouble diagnosis or problem resolution found not to be the fault of SMART CITY or 2) collect information required to complete the installation that customer fails to provide (i.e. floor plans or special circuit numbers) may be billed to the Customer at the prevailing rate. 16. Equipment Management: (a) Customers should pick up hubs, wireless devices, telephone instruments and other rental equipment at the Smart City Service Desk. (b) The Customer will be fully responsible for the protection and safekeeping of rental equipment and will be responsible for returning all rental equipment to the Smart City Service Desk within one (1) hour following close of the show. 17. The prices listed on this contract do not include Federal, State, Local or Other Taxes and Tax surcharges. Taxes / Tax surcharges will be included on your final bill. Federal Tax ID is 65-0524748. 18. NOTE: THE CUSTOMER IS RESPONSIBLE FOR ALL INTERNATIONAL LONG DISTANCE AND OTHER APPLICABLE CHARGES AGAINST ASSIGNED TELEPHONE NUMBER(S) 19. All Single Line, Multi-Line, and Dedicated Line Telephone services include Directory Assistance, Information, "0+", Operator assisted, 1-800, 950, credit card type call usage and unlimited Domestic Long Distance. International Call charges will apply. 20. Long Distance (International Calls) and Line Restrictions: (a) Credit Card restriction will only allow Local, "1-800" and Credit Card calling. Intl restriction will block all International calling but allow all other type calls. (b) All lines will be blocked from "976" and "900" dialing unless otherwise requested. Additional deposits may be applicable. (c) Smart City will provide a detailed listing of all toll / billable type calls made from applicable services. Additional LD deposits required for Intl companies. 21. A per line move fee starting at \$100 (Telephone), \$200 (Internet) may apply to relocate the line(s) after it is installed. 22. Prices are based upon current rates and are subject to change without notice. |
|--|--|

(1) All Customer contracts and agreements are solely between SMART CITY and the prospective Customer; (2) SMART CITY is not the employee, agent or partner of the Facility; (3) The Facility is not a party to, nor shall it have any obligations or liabilities whatsoever to any Customer, under any Customer Contract including without limitation, the obligation to provide any of the services covered by such Customer Contract; (4) No representations or warranties are being made by the Facility with respect to any Customer Contract or any Communications Services; (5) The right of the Customer to receive any Communications Service will be terminated if this Agreement is terminated for any reason provided therein; and the Facility will have no obligation to continue providing such service unless the Facility elects in its sole discretion to continue to provide such services itself or through a third party; (6) The provisions of the Customer Contract are separate and independent from the provisions of the Customer's lease space in the building and shall not affect the Customer's obligations under such lease and without limiting the foregoing, in no event shall any default by SMART CITY under the Customer Contract or any failure with respect to any Communications Services have any effect on any Customer's obligations to the Facility under any lease or any other occupancy agreement between such Customer and the Facility.

- | | |
|---|--|
| <ol style="list-style-type: none"> 23. A valid Credit Card number with signature MUST be on file regardless of payment method. For your convenience we will use this authorization to charge your credit card for any additional amounts incurred. 24. Smart City accepts payments in US dollars, Checks drawn on a US bank, Wire Transfers or the following Credit Cards: (Amex, MasterCard, Visa,). Make all checks payable to: Smart City. 25. Due to the cost of processing checks, any refunds due in the amount of \$10.00 or less will not be refunded except upon written request. | <p style="text-align: center;">Mail or Fax Completed Orders with Payment and Floor Plan To</p> <p style="text-align: center;">SMART CITY
5795 W. BADURA AVENUE, SUITE 110
LAS VEGAS, NEVADA 89118
(888) 446-6911 FAX (702) 943-6001</p> |
|---|--|

Customer Acceptance of All Smart City Terms and Conditions / Attachments:

With execution of this document the Customer hereby authorizes Smart City to provide services as requested herein, is authorized to request such services and acknowledges full and complete understanding of the Terms and Conditions and Attachments contained herein & Website.

Print Authorized Name	Authorized Signature	Date
FOR SMART CITY USE: Payment Rec'd (Amount):	Customer No: 2013 - 029 -	

ORDER ON LINE: <https://www.smartcitynetworks.com/order/center.aspx?center=029>

*** Tipping is not permitted. Any request from personnel for gratuities should be reported to Management immediately. ***

Network Security Declaration

Center: Phoenix CC - (029) - AZ Company Name: _____
Show: _____ Booth / Room #: _____
Customer / Ref #: 2013 - 029 -

The Network Security Policy implemented for this Facility requires Customer(s) adherence to several necessary precautions in order for Smart City to maintain a healthy, viable network for all Customers. This declaration of compliance with the security requirements as noted herein is an acknowledgement of Smart City's filtering policies and must be completed, signed by an authorized Customer representative and mailed or faxed to Smart City prior to the requested network service(s) being activated for Customer's usage.

Network Security Policy:

Smart City requires that all devices directly or indirectly accessing Smart City's network(s) have the latest virus scan software, Windows® security updates, system patches, and any other technological precautions necessary to protect the Customer(s) and others from viruses, malicious programs, and other disruptive applications. Any device(s) which adversely impacts Smart City's network(s) may cause service interruptions to Customer(s) which can lead to disconnection of the Customer's equipment from the network(s), with or without prior notice at Smart City's sole discretion. The device(s) in question will remain disconnected until all issues are adequately resolved. All charges will apply and no refunds will be given. Additional charges may apply for trouble diagnosis and / or problem resolution.

Smart City has implemented filtering policies on all Internet routers. These filters block all inbound Internet Control Message Protocol (ICMP) -- Ping, Traceroute, etc. -- destined to any Smart City Network(s). Smart City understands that Ping and Traceroute are valuable troubleshooting tools; therefore Smart City's Policy does allow ICMP (Ping & Traceroute) packets sourced from any Smart City network(s).

Further, to avoid infection by common Internet worms (Nachi, MSBlaster, LoveSAN, etc.), Smart City has implemented similar filters on the following TCP and UDP port numbers: UDP – 137, 138, 402, 1434 and TCP – 135, 139, 402, 445, 4444.

Customers requiring inbound or outbound access to any of the filtered ports, should contact a Smart City customer service representative in advance of the event with details of the specific requirements so that Smart City may consider the potential of a customized alternative.

Each Customer's business is important to Smart City and with advanced and timely notification of a Customer's needs we are confident that we can provide network services that perform as expected for all clients.

***** Please inform all show site personnel about the importance of Smart City's Network Security compliance issues *****

***** Services are activated after Smart City is in receipt of this signed declaration of compliance with our network security requirements *****

Device(s) Operating System: _____ Total # of Devices: _____

Type of Anti-Virus Software Installed: Norton McAfee Other: _____

Virus Scan Last Updated - Date: _____ / _____ / _____ Security Updates Last Performed - Date: _____ / _____ / _____

Are You Renting Computers? Yes No Rental Company Name: _____

Rental Company Contact: _____ Contact Number: _____

With execution of this document the Customer hereby attests that Customer provided equipment, which will be connected to Smart City's network(s) at the above noted Facility and Show / Event has been properly protected, contains anti-virus software, and the latest patches and security updates have been installed. Customer(s) also accepts the responsibility for the performance of Customer's equipment and understands the conditions placed on service delivery by this document as well as the potential that additional charges may be incurred should Customer's equipment be found to adversely impact Smart City's network(s) performance. The Customer acknowledges that this Network Security Declaration is part of the Customer Contract allowing Smart City to provide requested service(s) and is subject to change without notice.

Signature _____

Date _____

Printed Name _____

Title _____

Floor Plan – Communications Cable

Center: Phoenix CC - (029) - AZ

Company Name: _____

Show: _____

Booth / Room #: _____

Customer / Ref #: 2013 - 029 -

Voice and Data communications cabling. Smart City is the **exclusive installer** of Voice and Data communications cabling. Smart City provides cabling to booths, within booths (under carpet and flooring) and from booth-to-booth. Fiber Optic, twisted pair (Category 3, 5 and 6), coaxial and all other data and telecommunication cable fall under Smart City's area of expertise.

IMPORTANT!! Prior to installation of service, a complete floor plan is required. Please utilize this grid should you not have your own floor plan to send us. You may use a different floor plan for each service group (Telephone, Internet, etc.) or combine all services on one floor plan. For a floor plan to be considered complete it **must** include all the information listed below (Main Distribution Location "MDL", designated location of items within the booth, surrounding booths, scale-length and width).

Adjacent Booth or Aisle# _____

Adjacent Booth or Aisle# _____

X = Main Distribution Location (**MDL**) – The originating line(s) for service, whether from overhead, a floor pocket or a column, will be delivered to a "**MDL**" before being distributed within your booth. Example: Storage area, back of booth, etc. (unless specified, the default for the "**MDL**" will be the back of the booth or at Smart City's discretion, the most convenient location). All distribution of services to their final destination within the booth will originate from the "**MDL**". A per line move fee will apply to relocate services within your booth after they have been engineered and / or installed.

T = Location of Telephones, Fax lines or other telecommunications equipment "**T**".

I / H / PC / C = Location of primary Internet Service "**I**", Hubs "**H**", Patch Cables "**PC**" and / or Computers "**C**". For Smart City to perform your floor work, you will need to indicate the location of each item you want cabled. Make sure to order your floor work, hubs, and patch cables early and in advance of the show moving in.

Orientation = The Booth or Aisle #'s surrounding your booth. A minimum of one surrounding Booth or Aisle # is required (two or more would be more helpful) for Smart City to accurately install your services.

Size = Booth dimensions (example 10x10) _____ . **Scale** = 1 Box is equal to _____ ft.





SMART CITY
 5795 W. BADURA AVE, SUITE 110
 LAS VEGAS, NEVADA 89118
 888-446-6911
 702-943-6001 (FAX)



Company Name		Booth / Room	Show Name:
Billing Name		Show Dates: / / To / /	
Billing Address		Incentive Order Deadline: (see Incentive Price, Ts & Cs)	
City, State / Country, Zip		Email	
Contact	Telephone Number () -		Fax Number () -
Install Date / / Time / :	Removal Date / / Time / :	Cell Number () -	
Credit Card Number: <input type="checkbox"/> AMX <input type="checkbox"/> MC <input type="checkbox"/> Visa		Expire Date (MM / YY):	Sec Code:
Print Card Holder Name:		Card Holder Signature and/or Acceptance of T's & C's:	

Important! Review "Product Overview / Glossary" literature to assure the services you have selected will provide the functionality for any application(s) you will be utilizing. [View complete descriptions of Services and Terms & Conditions at smartcitynetworks.com/Facilities/Locations.aspx](http://smartcitynetworks.com/Facilities/Locations.aspx). Please call if assistance is needed. **Note Cancellation Policy Specifics – Terms & Conditions item #6 – This document, page / thumbnail 2.**

Description of Service	Type	Qty	Incentive	Base	Total
1. Standard Cable TV Services					
a. Basic Service – Digital (Local & Basic Cable Channels, CNN) ▪ One Cable TV drop is provided with each service ordered.	CTV-B		\$ 300.00	\$ 375.00	
b. Premium Service - Digital (Local & Expanded Cable Channels, CNN) ▪ One Cable TV drop is provided with each service ordered.	CTV-P		\$ 450.00	\$ 565.00	
c. Cable TV Converter / Set-Top Box Rental (1 per TV) – Potentially Required ▪ Not required if TV has a built in QAM Tuner.	CTV-BX				
d. Custom Requests (Additional Premium Channels & Other Services)	MTV		(Call 888-446-6911 for quote)		
2. Special Services					
a. Labor / Floor Work – Fee per hour	FW-TV		\$ 125.00	\$ 125.00	
3. Special Quote – Attachment A or SOW (if applicable)					
		MTV	(Call 888-446-6911 for quote)		
4. Move - In / On - Site order fee (if ordering service after show move-in has started).			(20%) x (Base Price)		
5. Distance Fee of \$500 for each drop / line outside the convention venue.			x (number of lines)		
					SUBTOTAL
					ESTIMATED 10% TAX / FEES DEPOSIT = SUBTOTAL x 10%
TOTAL PAYMENT MUST ACCOMPANY ORDER. Credit Card users may fax order to 702-943-6001					GRAND TOTAL

***** Incentive Price applies to orders received With Payment 14 days prior to the 1st day of show move-in. *****

Customer Acceptance of All Smart City Terms and Conditions / Attachments:

With execution of this document the Customer hereby authorizes Smart City to provide services as requested herein, is authorized to request such services and acknowledges full and complete understanding of the Terms and Conditions and Attachments contained herein.

Print Authorized Name		Authorized Signature		Date
FOR SMART CITY USE: Payment Rec'd (Amount):		Customer No: 2013 - 029 -		
Payment Type:	<input type="checkbox"/> Check <input type="checkbox"/> Money Order <input type="checkbox"/> Cash <input type="checkbox"/> Wire Transfer <input type="checkbox"/> American Express <input type="checkbox"/> MasterCard / Visa			
Note:	CSR:	Date:		

ORDER ON LINE: <https://www.smartcitynetworks.com/order/center.aspx?center=029>

CABLE TV ORDER FORM

TERMS AND CONDITIONS (continued from page 1)

<p>1. Smart City is the exclusive provider and installer of all Cable TV, Voice, Data and Network services (wired and wireless) including communications cabling. This includes all cabling to meeting rooms, booths, within booths (under carpet and flooring), fiber optic, twisted pair (Category 3, 5 and 6), coaxial and all other data and telecommunications related cabling.</p> <p>2. The use of the Cable TV connection(s) provided by Smart City may be used only by the directors, officers and employees of the Company, its guests, its agents and consultants while performing service for the Company and cannot be resold or distributed to other companies or individuals.</p> <p>3. Incentive Price applies when a completed order with payment is received no later than 14 days prior to the first day of show move-in. Base Price applies to (a) all orders received from One (1) to Thirteen (13) days before show move-in has started or (b) orders received on or before the 14 day Incentive Deadline without payment (c) orders placed on site or after show move-in has started will be at Base Price plus an additional \$75 line/drop.</p> <p>4. Unless otherwise directed, Smart City is authorized to cut floor coverings to permit installation of service.</p> <p>5. Only Smart City personnel are authorized to modify system wiring or cabling. Material and equipment furnished by Smart City for this service contract shall remain the property of Smart City.</p>	<p>6. CANCELLATION – There is a minimum \$150 or 10% Cancellation fee (whichever is greater). Cancellations must be in writing. Additional cancellation charges will apply for orders that have already incurred processing, labor, material, and / or engineering costs. Credit will not be given for service(s) installed and not used. Service problems must be reported to the Smart City Service Desk. Service claims will not be considered unless filed in writing by Customer prior to close of show.</p> <p>7. Any additional cost incurred by SMART CITY to: 1) assist in trouble diagnosis or problem resolution found not to be the fault of SMART CITY or 2) collect information required to complete the installation that customer fails to provide (i.e. floor plans) may be billed to the Customer at the prevailing rate.</p> <p>8. A per line move fee starting at \$200 may apply to relocate the line(s) after it is installed.</p> <p>9. The prices listed on this contract do not include Federal, State, Local or Other Taxes and Tax surcharges. Taxes / Tax surcharges will be included on your final bill. Federal Tax ID is 65-0524748.</p> <p>10. Prices are based upon current rates and are subject to change without notice.</p> <p>11. The Customer will be responsible for returning all rental equipment to the Smart City Service Desk within one (1) hour following close of the show. Missing equipment will incur charges at prevailing rates.</p>
---	---

RESTRICTIONS / CHANGES

Customer acknowledges and agrees that it is prohibited by federal copyright law and the Cable Company's agreements with its programming providers from several usage scenarios as follows - Customer shall not, nor authorize or permit any other person to: (a) charge a cover charge or admission fee to the Premises for any cable television programming or cable related event, including, but not limited to, premium services and pay-per-view events, without the prior written consent of Smart City; (b) copy, record, dub, reproduce or alter any cable television programming/service or any part thereof; (c) transmit cable service beyond the outlets on the Premises installed by Smart City or authorized hereunder; or (d) permit the transmission, display or recording of any premium channel or pay-per-view event; or (e) tamper with or modify the cable converter unit, remote control device or any other equipment provided by Smart City to the Customer.

In the event the Customer engages in any of the conduct described above, in addition to any other remedies available at law or in equity, Smart City may terminate the cable services. All charges will apply and no refunds will be given. Additional charges may apply for problem resolution of any restriction violation.

Customer acknowledges and agrees that the Cable Company has the right at any time to preempt, without prior notice, specific programs and to determine what substitute programming, if any, shall be made available.

LIMITATION OF LIABILITY

Limited Warranty. SMART CITY warrants that: (a) it has the right to provide all CTV and Cable TV services (the "Services"). In the event that the Services are not performed in accordance with this warranty you agree to inform SMART CITY of such fact, by written notice prior to close of the Show / Event, and, as your sole and exclusive remedy, SMART CITY will either: (a) repair or replace the Services to correct any defects in performance without any additional charge to you, or (b) in the event that such repair or replacement cannot be done within a reasonable time, terminate the Customer Contract and provide you with a pro rata refund of the fees paid to SMART CITY for the Services hereunder with respect to such calendar year.

LIMITATION OF LIABILITY. EXCEPT FOR OUR WILLFUL MISCONDUCT OR GROSS NEGLIGENCE, YOU AGREE THAT UNDER NO CIRCUMSTANCES IS SMART CITY LIABLE TO YOU FOR ANY INDIRECT, INCIDENTAL, SPECIAL, PUNITIVE OR CONSEQUENTIAL DAMAGES OR LOST PROFITS ARISING OUT OF THE SYSTEMS OR OUR SERVICES OR OBLIGATIONS UNDER THIS AGREEMENT EVEN IF SMART CITY HAS BEEN ADVISED OF THE POSSIBILITY OF SUCH DAMAGES. IN ANY EVENT, YOUR EXCLUSIVE REMEDY AND OUR ENTIRE LIABILITY TO YOU FOR ANY REASON UPON ANY CAUSE OF ACTION ARISING OUT OF THE SYSTEM OR OUR SERVICES UNDER THIS AGREEMENT SHALL BE THE AMOUNT ACTUALLY PAID BY YOU TO SMART CITY WITH RESPECT TO THOSE DEFICIENT SERVICES. THE LIMITATION OF LIABILITY PROVIDED BY THIS SECTION IS LIMITED TO OUR DUTIES AND LIABILITIES BY REASON OF THIS AGREEMENT ONLY, AND DOES NOT AFFECT ANY OTHER RELATIONSHIP SMART CITY MAY HAVE WITH YOU.

NO ACTION, REGARDLESS OF FORM, ARISING OUT OF OR RELATED TO THE USE OF THE SERVICES PURSUANT TO THIS AGREEMENT MAY BE BROUGHT BY YOU MORE THAN 12 MONTHS AFTER THE CAUSE OF ACTION FIRST AROSE.

(1) All Customer contracts and agreements are solely between SMART CITY and the prospective Customer; (2) SMART CITY is not the employee, agent or partner of the Facility; (3) The Facility is not a party to, nor shall it have any obligations or liabilities whatsoever to any Customer, under any Customer Contract including without limitation, the obligation to provide any of the services covered by such Customer Contract; (4) No representations or warranties are being made by the Facility with respect to any Customer Contract or any Communications Services; (5) The right of the Customer to receive any Communications Service will be terminated if this Agreement is terminated for any reason provided therein; and the Facility will have no obligation to continue providing such service unless the Facility elects in its sole discretion to continue to provide such services itself or through a third party; (6) The provisions of the Customer Contract are separate and independent from the provisions of the Customer's lease space in the building and shall not affect the Customer's obligations under such lease and without limiting the foregoing, in no event shall any default by SMART CITY under the Customer Contract or any failure with respect to any Communications Services have any effect on any Customer's obligations to the Facility under any lease or any other occupancy agreement between such Customer and the Facility.

<p>12. A valid Credit Card number with signature MUST be on file regardless of payment method. For your convenience we will use this authorization to charge your credit card for any additional amounts incurred.</p> <p>13. Smart City accepts payments in US dollars, Checks drawn on a US bank, Wire Transfers or the following Credit Cards: (Amex, MasterCard, Visa,). Make all checks payable to: Smart City.</p> <p>14. Due to the cost of processing checks, any refunds due in the amount of \$10.00 or less will not be refunded except upon written request.</p>	<p>Mail or Fax Completed Orders with Payment and Floor Plan To</p> <p>SMART CITY 5795 W. BADURA AVENUE, SUITE 110 LAS VEGAS, NEVADA 89118 (888) 446-6911 FAX (702) 943-6001</p>
--	---

ORDER ON LINE: <https://www.smartcitynetworks.com/order/center.aspx?center=029>

***** Tipping is not permitted. Any request from personnel for gratuities should be reported to Management immediately. *****

PLANT & FLORAL ORDER FORM

2013 Big O Tires Convention
 Phoenix Convention Center - South Building
 April 23, 2013

EVENTS N MORE
 602.810.1582 - PHONE
 480.393.5378 – FAX

Payment in full must be received 10 days prior to show opening to receive discount pricing.

BLOOMING PLANTS - Table tops, planter boxes & desks	Disc. Price	Regular Price	Quantity	Total
MUM: Yellow ___ White ___ Lavender ___	\$20.00	\$25.00		
AZALEA: Red ___ Pink ___ White ___	25.00	30.00		
BROMELIAD: Red ___ Yellow ___ Pink ___	25.00	30.00		
KALANCHOE: Red ___ Yellow ___ Orange ___	20.00	25.00		
Colors may vary upon season				
FOLIAGE PLANTS - Table tops, floor corners				
REGULAR PLANTS: Ferns ___ Ivy ___ Pothos ___	20.00	25.00		
LARGE PLANTS: Ferns ___ Ivy ___ Pothos ___	30.00	40.00		
LARGE FLOOR PLANTS				
2-3 FOOT GREEN PLANT	39.00	49.00		
3-4 FOOT GREEN PLANT	49.00	59.00		
4-5 FOOT GREEN PLANT	59.00	69.00		
5-6 FOOT GREEN PLANT	69.00	79.00		
7 FOOT GREEN PLANT OR LARGER	CALL	CALL		
CUSTOM FLORAL ARRANGEMENTS				
MEDIUM - 10" Wide X 12" High; Color _____ Shape _____	50.00	60.00		
LARGE - 12" Wide X 18" High; Color _____ Shape _____	65.00	75.00		
Type of Container: Vase ___ Dish ___ Basket ___				
CORSAGE/ BOUTONNIERS	15.00	20.00		
SPECIALITY ITEMS				
CACTUS GARDENS – MEDIUM	20.00	30.00		
CACTUS GARDENS - LARGE	35.00	42.00		
SPECIAL SERVICES AVAILABLE ON REQUEST—Balloons, Floral Arrangements, Hospitality Suites, Luncheons and Banquets.				
**All plants and material supplied on a rental basis only. Items damaged or missing from exhibitor's booth are the responsibility of the exhibitor and additional charges will apply. Prices include installation, servicing & removal.		TOTAL ORDER		
		SALES TAX - 9.3%		
		DELIVERY FEE - 15%		
All Rental items will remain the property of Events N More, LLC.		TOTAL PAYMENT DUE		

All orders must be paid in full prior to the opening of the show/event. No adjustments will be made after the close of the show/event. All cancellations must be made 10 days prior to show/event.

PAYMENT INFORMATION: Credit Card - Circle One: VISA, MasterCard or American Express
 Check Enclosed (Payable to: Events N More)

Card Number: _____ Expiration Date: ____/____
 Name on Card: _____
 Billing Address: _____
 City: _____ State: _____ Zip: _____
 Phone: _____ Email: _____
 Authorized Signature: _____
 On-site Contact: _____ Phone: _____
 Exhibiting Company: _____ Booth# _____

MAIL OR FAX COMPLETED FORM TO:
EVENTS N MORE PLANT N FLORAL
 4340 E. Indian School Rd. Ste. 21-220
 Phoenix, AZ 85018
 602.810.1582 Phone 480.393.5378 Fax
 plantrental@eventsnmore.org

2013 Big O Tires Convention

Phoenix Convention Center

April 23, 2013

3

3rd Party Billing Request, Page 67

A

Additional Service Order Forms, Page 69

Advance Shipping Labels, Page 19

Air and Water, Page 75

Audio Visual Order Form, Page 70

B

Booth Layout Form, Page 68

C

Cable TV Order Form, Page 81

Carpet Brochure, Page 28

Carpet Order Form, Page 30

Carpet Package Order Form, Page 31

Cartload Service Order Form, Page 26

Certificate of Liability Insurance: **SAMPLE COPY**, Page 14

Cleaning Order Form, Page 65

Convenience Package Order Form, Page 46

Custom Graphics Brochure, Page 57

D

Digital File Preparation, Page 55

Direct Shipping Labels, Page 20

Domestic Shipping Quote Form: **GES Logistics**, Page 22**E**

Electrical, Page 73

Exhibitor Appointed Contractor: Notice of Intent to Use, Page 15

F

Fire Regulation Information, Page 10

Furniture & Accessories Order Form, Page 34

G

General Information, Page 5

GES Global Transportation Plus, Page 23

GES Information and Order Forms, Page 3

GES Logistics - Domestic Shipping Quote Form, Page 22

GES Logistics - International Shipping Quote Form, Page 24

GES Terms & Conditions of Contract, Page 9

GES Transportation Plus, Page 17

Graphics & Signage Order Form, Page 56

H

Hanging Sign / Truss Labor Information, Page 61

Hanging Sign / Truss Labor Order Form, Page 62

Hanging Sign Shipping Labels, Page 63

I

In-Booth Forklift & Labor Order Form, Page 60

Installation & Dismantling Order Form, Page 58

International Shipping Quote Form: **GES Logistics**, Page 24

2013 Big O Tires Convention

Phoenix Convention Center

April 23, 2013

Internet - Network / Telephone Services, Page 77**K****Key Information\Supervised Labor Checklist, Page 59****M****Material Handling Information, Page 16****Material Handling Order Form, Page 18****N****Notice of Intent to Use Exhibitor Appointed Contractor, Page 15****O****Official Service Provider Information, Page 13****Operation of All Mechanical Lifts, Page 11****P****Payment & Credit Card Charge Authorization, Page 66****Petroleum Surcharge Information, Page 12****Plant & Floral, Page 83****Pre-Printed Outbound Material Handling Request, Page 21****S****SAMPLE COPY: Certificate of Liability Insurance, Page 14****Shipping Labels: Advance, Page 19****Shipping Labels: Direct, Page 20****Show Information, Page 4****Show Site Work Rules, Page 8****Sign Hanging & Rigging Indemnification Form, Page 64****Skid Accessible Storage Order Form, Page 25****Specialty Furniture Brochure, Page 35****Specialty Furniture Order Form, Page 44****Standard Exhibit Systems Brochure, Page 47****Standard Exhibit Systems Order Form, Page 54****Standard Furniture Brochure, Page 32****Stop. Think. Safety., Page 7****Supervised Labor Checklist & Key Information, Page 59****T****Terms & Conditions of Contract: GES, Page 9****Trade Show Tips, Page 6****V****Vehicle Placement Order Form, Page 27**