

Las Vegas

BUILDING USERS MANUAL

2017

LAS VEGAS CONVENTION CENTER • CASHMAN CENTER



Las Vegas Convention and Visitors Authority
3150 Paradise Road, Las Vegas NV 89109-9096
702-892-0711 • Fax: 702-892-2824
LVCVA.com • VegasMeansBusiness.com



April 5, 2017

Welcome to Las Vegas and the Las Vegas Convention Center and Cashman Center!

This 2017 edition of the Building User's Manual has been compiled to assist you in your efforts to produce a successful show. Current policies and procedures are contained within, as well as rules and regulations related to safety, fire code, etc.

A Convention Services Manager (CSM) is assigned specifically to your show to act as your liaison with various departments of the Convention Center/Cashman Center throughout your entire planning process. If you have any questions about any of the items covered in this manual, please contact your **Convention Services Manager** first. He/she will be able to handle your inquiry quickly and efficiently on your behalf.

Since policies have a way of changing, your assigned CSM will ask you for your e-mail address so we can keep you informed of any revisions. Your CSM will also handle any special requests and answer any questions you may have about the facility.

Thank you for allowing us to be the venue for your event. We wish you continued success.

Sincerely,

A handwritten signature in cursive script that reads "Patrick Coyne".

Patrick Coyne
Senior Director of Convention Services
Las Vegas Convention and Visitors Authority

TABLE OF CONTENTS

MEET THE TEAM 6

FACILITY CONTACT INFORMATION 9

WEBSITES.....	9
SOCIAL MEDIA.....	9

BUILDING GUIDELINES 10

ADVERTISING AND CUSTOM SIGNAGE.....	10
ADVERTISING.....	10
CUSTOM SIGNAGE ONLY IN APPROVED LOCATIONS.....	10
❖ ADHESION.....	10
❖ WALL CLINGS.....	10
❖ PROHIBITED.....	10
AEROSOL CANS.....	11
AIR CONDITIONING AND HEATING.....	11
AMERICAN EXPRESS OPEN®.....	11
ANIMALS.....	11
BALLOONS.....	12
❖ INDOORS.....	12
❖ OUTDOORS.....	12
BOOTH SET-UP.....	13
BROADCAST AND PUBLICATIONS.....	13
BUILDING CHECKLIST:.....	14
BUSINESS CENTER.....	14
CATWALK ACCESS.....	15
CHEMICALS.....	15
CHILD CARE.....	15
DIGITAL ADVERTISING.....	15
REMOTELY PILOTED AIRCRAFT SYSTEMS (RPAS)/UNMANNED AERIAL VEHICLES (UAVs)/DRONES GUIDELINES.....	16
❖ EXHIBIT HALLS/MEETING ROOMS/OUTDOORS.....	16
❖ OUTDOORS.....	16
ELEVATORS AND ESCALATORS.....	16
EMERGENCY SITUATIONS.....	16
EXCLUSIVES.....	16
EXIT SIGNS.....	17
FIREARMS ON DISPLAY.....	17
FOG MACHINES.....	17
GREEN INITIATIVES.....	17
HEAVY EQUIPMENT PROCEDURES.....	17
HELICOPTERS.....	18
INDOOR AIR QUALITY.....	18
JANITORIAL AND CLEANING SERVICE.....	18
KEYS CARDS/ACCESS LOCKS.....	19
LOBBIES.....	19
LVCVA EMPLOYEE ACCESS.....	19
MARQUEE.....	19
MASSAGE SERVICES.....	19
MONORAIL – LIMITS OF APPROACH.....	20
OUTDOOR EXHIBITS.....	20
❖ RULES AND REGULATIONS.....	20
❖ TENTS & CANOPIES.....	21
❖ STAKING.....	21
❖ TRUSS STRUCTURES.....	21
PAGING.....	21
PERSONAL MOBILITY DEVICES.....	22
ROOF ACCESS.....	22
❖ EQUIPMENT INSTALLATION.....	22
❖ PROHIBITED.....	22
SATELLITE/ANTENNA INSTALLATION (refer to roof access).....	22

SECURITY STANDARDS PROGRAM.....	22
SERVICES.....	23
SHIPPING AND RECEIVING OF EXHIBITOR MATERIALS/PRODUCTS.....	23
SKY BRIDGE LIGHTBOX ADVERTISING.....	24
SKY DIVING.....	24
SOUND LEVELS.....	25
TRANSPORTATION & TRAFFIC PLANS.....	25
UNION AND NON-UNION LABOR DISPUTES.....	25
VEHICLES.....	26
WEAPONS.....	26
EXHIBITION AND MEETING SPACE 26	
MEETING ROOMS.....	26
❖ MEETING ROOM EQUIPMENT (provided).....	27
❖ MEETING ROOM EQUIPMENT (NOT provided).....	27
SHOW POWER IN MEETING ROOMS.....	28
OFFICIAL SERVICE CONTRACTOR RULES AND POLICIES 29	
BADGES/CONTRACTOR PHOTO IDENTIFICATION.....	29
BIKE/CART POLICY.....	30
ANNUAL REGISTRATION AND INSPECTION.....	30
CART CHARGING.....	30
PROHIBITED/RESTRICTIONS.....	30
SAFETY.....	30
OFFICIAL SERVICE CONTRACTOR RULES AND POLICIES.....	31
BUILDING DAMAGE.....	31
CLEANING.....	31
FLOOR PLANS.....	32
FIRE PREVENTION RULES AND REGULATIONS.....	32
TRAILER & EMPTY STORAGE.....	33
UTILITIES.....	33
ADDITIONAL PLANNING NOTES.....	34
OFFICIAL SERVICE CONTRACTOR AND VENDOR REQUIREMENTS.....	35
FLORAL/PLANT CONTRACTORS RULES.....	35
HAND CARRY.....	35
HOT WORK.....	36
RIGGING.....	37
RIGGING SUBMITTAL PROCEDURE.....	38
FEDERAL AND STATE GUIDELINES 39	
ADA – AMERICANS WITH DISABILITIES ACT.....	39
SERVICE ANIMALS.....	39
NEVADA DEPARTMENT OF TAXATION.....	39
NON-SMOKING POLICY.....	39
RAFFLES.....	39
LEASING AND INSURANCE 40	
INSURANCE AND INDEMNITY.....	40
LEASE.....	40
LICENSES –CASHMAN ONLY LEASE.....	40
PARKING LOTS 41	
PUBLIC EVENTS 42	
GUN SHOW POLICIES AND PROCEDURES.....	42
SAFETY 42	
FIRE AND SAFETY EXHIBIT GUIDELINES.....	42
FLOOR PLANS.....	44
❖ FLOOR PLAN GUIDELINES.....	44
❖ SUBMITTAL INSTRUCTIONS.....	44
FOOD PREPARATION WITHIN EXHIBITS.....	45
EXHIBITION AND DISPLAY COOKING.....	45
FOOD SAMPLING INFORMATION FOR EXHIBITORS.....	46
EXHIBITORS WHO ARE SAMPLING FOOD & BEVERAGES.....	Error! Bookmark not defined.
EVENT COORDINATORS PERMIT FOR A SAMPLING SHOW.....	Error! Bookmark not defined.
HALOGEN LAMP RESTRICTIONS.....	47

UNAPPROVED HALOGEN BULBS.....	47
APPROVED HALOGEN BULBS – 75 watts max	47
MULTI-LEVEL AND/OR COVERED EXHIBITS	48
RULES AND REGULATIONS	48
FIRE WATCH	48
PERMITS.....	48
PYROTECHNICS AND SPECIAL EFFECTS	49
SECURITY 51	
CONTRACT SECURITY STANDARDS OF PERFORMANCE	51
SECURITY COMPANIES (PRIVATE).....	54
RULES AND REGULATIONS	55
WEAPONS	55
FORMS 56	
FOOD and BEVERAGE SAMPLING/ON-SITE FOOD PREPARTION APPROVAL FORM.....	56
APPOINTED CONTRACTOR & VENDOR REQUIREMENTS (pg 1).....	57
EXHIBITOR APPOINTED CONTRACTOR & VENDOR REQUIREMENTS (pg 1)	57
EXHIBITOR APPOINTED CONTRACTOR & VENDOR REQUIREMENTS (pg 2)	58
HELICOPTER LANDING REQUEST FORM.....	59
SAMPLE INSURANCE CERTIFICATE	60
WEAPONS REQUEST FORM.....	62
REMOTELY PILOTED AIRCRAFT SYSTEMS (RPAS)/ UAV/ DRONES.....	63

MEET THE TEAM CONVENTION SERVICES



PATRICK COYNE
Senior Director of
Convention Services
CEM, CMP
pcoyne@lvcva.com
Ph (702) 892-2904
Cell (702) 400-2143
Fax (702) 892-2933



DEANNE STONEY
Senior Convention
Services Manager
CEM, CMP
dstoney@lvcva.com
Ph (702) 892-2941
Cell (702) 400-2237
Fax (702) 892-2933



STEVE PATTERSON
Senior Convention
Services Manager, CEM
spatterson@lvcva.com
Ph (702) 892-7575
Cell (702) 249-3167
Fax (702) 892-2933



KEVIN AIVAZ
Senior Convention
Services Manager, CEM
kaivaz@lvcva.com
Ph (702) 892-2969
Cell (702) 477-9222
Fax (702) 892-2933



RUTH CHAN

Associate Convention Services Manager

rchan@lvcva.com

Ph (702) 892-2940

Cell (702) 301-8487

Fax (702) 892-2933



WILLIAM FLANGAS

Convention Services Manager

wflangas@lvcva.com

Ph (702) 892-7513

Cell (702) 285-3804

Fax (702) 892-2933



CINDY GRUBER

Convention Services Manager, CEM

cgruber@lvcva.com

Ph (702) 892-2932

Cell (702) 353-5228

Fax (702) 386-7126



BERTHA JARDINE

Convention Services Manager

bjardine@lvcva.com

Ph (702) 892-2924

Cell (702) 239-8349

Fax (702) 386-7126



HELEN LAVINE

Convention Services Manager, CEM, CMP

hlavine@lvcva.com

Ph (702) 386-7103

Cell (702) 806-3026

Fax (702) 386-7126



CHRIS MOESLACHER

Convention Services Manager, CEM

cmoeslacher@lvcva.com

Ph (702) 386-7112

Cell (702) 343-0335

Fax (702) 892-2933



SCOTT NEWCOMB

Convention Services Manager

snewcomb@lvcva.com

Ph (702) 386-7162

Cell (702) 265-6240

Fax (702) 892-2933

FACILITY CONTACT INFORMATION

Administration/Convention Services	(702) 892-2960
American Express OPEN®	(702) 943-6990
Centerplate Food & Beverage Services	(702) 943-6779
Centerplate Fax	(702) 943-6782
COX Business	(702) 943-6500
FedEx	(702) 943-6780
Las Vegas Convention Center	(702) 892-0711
Cashman Center	(702) 386-7110
Registration Services	(702) 386-7828
Fire Prevention Office	(702) 892-7413
Customer Safety Dispatch	(702) 892-7400

WEBSITES

- LVCVA Meeting Planner Website vegasmmeansbusiness.com
- LVCVA Corporate Website LVCVA.com
- LVCVA Consumer Website VisitLasVegas.com

SOCIAL MEDIA

- [Twitter.com/lvcva](https://twitter.com/lvcva)
- [Twitter.com/vegas](https://twitter.com/vegas)
- [Facebook.com/lasvegas](https://facebook.com/lasvegas)
- [Youtube.com/lasvegas](https://youtube.com/lasvegas)
- instagram.com/vegas
- lasvegas.tumblr
- vine.co/Vegas
- pinterest.com/visitlasvegas

BUILDING GUIDELINES

ADVERTISING AND CUSTOM SIGNAGE

ADVERTISING

- Commercial exhibitor advertising is not allowed in the public areas of the facility centers, including parking lots, without payment of additional compensation to the Las Vegas Convention & Visitors Authority (LVCVA)
- The current rate for all public areas is fifteen percent (15%) of show management’s gross revenue.
- You will be required to furnish the LVCVA with a list of all advertising sold in public areas 30 days prior to the first day of move-in, including a rate card and copy of invoice.

CUSTOM SIGNAGE ONLY IN APPROVED LOCATIONS

- Banners and signage may be attached to the facility only in approved locations and by approved methods. Please contact your Convention Services Manager (CSM) with questions.
- When there are multiple events in the building your Convention Services Manager will approve the appropriate locations for all banners/signage in public areas.
- Freestanding signs (i.e. kiosks, meter boards, etc.) must have a base design that is approved by the Convention Services Manager and the facility Fire Prevention Office. Show floor plans shall indicate proposed location of all freestanding signs, both within any exhibit hall, lobby or plaza. Placement of freestanding signs requires approval of the Convention Services Manager and the facility Fire Prevention Office.

CASHMAN CENTER

- For your convenience, Cashman Center has established permanent hang points for banners in the following locations:

<u>Location</u>	<u>Overall Dimension</u>
Hall A entrance	30’ x 8’
Hall B entrance	30’ x 8’
Meeting Rooms entrance	30’ x 8’
Theater entrance	24’ x 8’

❖ ADHESION

- Nails, tacks, screws and tape will not be used to hang signs and banners.
- Any approved signs placed on windows (i.e. static cling, foam core, etc.) must not leave residue on the window surface.
- Stickers are not allowed on facility property.
- Signs and banners placed outside of the building must lie flat against the building and be properly secured.

❖ WALL CLINGS

- Use of wall clings must be approved in advance by your CSM.
- Only approved materials can be used. Ask your CSM or Official Service Contractor for substrate specifications.
- All clings must be installed/removed by the Official Service Contractor.
- Message on cling may be directional, association related or advertising/sponsorships. Clings used for advertising/sponsorship are subject to the 15% of receipts for advertising.
- The Official Service Contractor is responsible for any chargeback for repairs of damages incurred during installation or removal of wall cling.
- Contact your CSM for product information and locations.

❖ PROHIBITED

- Permanent facility digital signage screens and commercial signage may not be visibly blocked in any manner. This includes directional graphics, emergency exits, rest rooms, concessions, exhibit hall signs, exhibitor service signs, commercial advertising, etc.

- Show signs and/or decorations may not be attached to the permanent facility graphics, and the removal of such is strictly prohibited.
- Arbor counterweights will be loaded on arbors or stored in designated area, counterweights are not to be removed from the stage area.

LVCC

- The beams in the grand lobby, central concourse and south halls are not approved as weight bearing structures.
- Hanging or placing signs or banners from the Paradise Road pedestrian bridge, from any of the Desert Inn bridges, the monorail or from the South meeting rooms is prohibited.
- Signage may not be placed inside or outside of the windows of the Paradise Road pedestrian bridge or any of the Desert Inn bridges.
- Signs and banners are not permitted on the light poles on LVCC property. Banners, posters or advertising on light poles off LVCC property is a violation of state or county codes and will be removed at the expense of the lessee. The lessee may also be cited and fined, and it will be the lessee's responsibility to bill the offending exhibitors.

CASHMAN CENTER

- Signs and banners are permitted on the light poles on Cashman Center property. Labor and materials are the responsibility of the Lessee. When used to promote the association or event, the pole sign brackets are at no charge. Commercial advertising is permitted and is subject to LVCVA revenue percentage. Banners, posters or advertising on light poles off Cashman Center property is a violation of state or county codes and will be removed at the expense of the association or event. The association or event may also be cited and fined, and it will be the Lessee's responsibility to bill the offending exhibitors.

AEROSOL CANS

- Aerosol cans containing flammable gases or liquids are prohibited. Only empty containers may be placed on display.
- Flammable liquids, solids or gases, are prohibited inside the building unless prior review and approval is obtained.

AIR CONDITIONING AND HEATING

- The facility provides cooling or heating in the exhibit halls during show hours. Fees are charged per hall, per day, for cooling and heating during non-show days. Contact your Convention Services Manager for a price quote.

AMERICAN EXPRESS OPEN®

LVCC

- American Express OPEN®, the Official Small Business Card of the Las Vegas Convention Center has launched the American Express OPEN® Business Lounge near the main entrance to the LVCC.
- The lounge offers OPEN card members and new applicants a quiet oasis to recharge and do business with amenities including comfortable seating, Wi-Fi, laptops, printers, coffee, tea, and light snacks.
- Business owners who are not Card members can apply for an OPEN Card with representatives at American Express OPEN® kiosks located in the lobby area of the Central, North, and South Halls.
- American Express OPEN® is the leading payment card issuer for small businesses in the United States, supporting business owners with products and services to help them run and grow their businesses. Learn more at www.OPEN.com

ANIMALS

- Service animals are always welcome. Refer to the American Disabilities Act (ADA) for the definition of a service animal.

- Permission for any animal to appear in a show or booth must first be approved by show management, then by the Convention Services Manager (CSM).
- The animal must have something to do with the booth or show (i.e., a dog used in commercials, films, etc.).
- It is the animal owner's responsibility to clean up after the animal while on facility property.
- The following criteria must be met before the animal is allowed on property:
 - A separate certificate of insurance in the amount of \$1 million combined single limit bodily injury and broad form property damage coverage, including broad form contractual liability, naming the Las Vegas Convention and Visitors Authority as additional insured must be provided.
 - Animals, with the exception of fish, are not allowed in the building overnight.
 - A trainer must accompany animals at all times.

BALLOONS

Show management and your Convention Services Manager (CSM) must approve the use of balloons.

❖ INDOORS

PERMITTED

- Helium balloons larger than 36 inches separate or tethered, are allowed in the exhibit halls.
- Helium balloon columns and arches are permitted in public space or meeting room areas as long as balloons are properly anchored.
- Large helium-filled balloons, such as advertising balloons, may be used only if they are securely anchored to the exhibit.
- Balloons may be used outside but must be tethered and may require FAA approval.

PROHIBITED

- Overnight storage of helium or compressed air cylinders in the building is prohibited.
- Helium balloons may not be used for handouts, however smaller air-filled balloons may be used for decoration and/or handouts.
- No helium balloons or blimps may be flown around the exhibit hall.
- Balloons may not be released outdoors due to airport flight patterns in the area.

ADDITIONAL PLANNING NOTES

- Helium gas cylinders used for refilling must be secured in an upright position on ANSI (American National Standards Institute) approved fire prevention stands with the regulators and gauges protected from potential damage.
- Balloons must be removed from the property by the exhibitor or the company who provided them. Balloons must not be left for the Official Service Contractor, cleaning contractor or the facility.

❖ OUTDOORS

Moored balloons (to include hot air balloons), and kites are permitted on facility campuses with the following conditions:

- Must have approval from show management and your Convention Services Manager (CSM)
- Balloons/kites must be moored and can only be used for displays. Must submit mooring plan to the Las Vegas Convention Center.
- Balloons/kites must not protrude higher than the building structure of the facility

HOT AIR BALLOON OPERATIONS

- Any hot air balloon that is inflated and standing must have a FAA certified pilot, with a commercial rating for lighter than air aircraft with the balloon at all times.
- Balloons cannot be flown on facility campuses due to the proximity to the local airports, this is an FAA regulation.
 - McCarran International Airport is less than 5 miles from LVCC
 - North Las Vegas Airport is less than 5 miles from Cashman Center

- Propane cylinders awaiting use must be stored in a secured propane storage cage that meets the requirements of OSHA. Storage cages must be secured in a location selected by LVCVA staff outside of the building

RUNAWAY BALLONS

- If a balloon escapes its mooring and poses a threat to air navigation, the operator of the unmanned balloon must report the runaway balloon to air traffic control with the estimated position of the balloon and the time it escaped its mooring.

BOOTH SET-UP

If approved by Show management an exhibitor has the option of contracting the set-up of their booth or setting up the booth themselves. If an exhibitor opts to set up their own booth, the individuals doing the setup must be full time employees of the exhibiting company and able to provide credentials.

BROADCAST AND PUBLICATIONS

- The LVCVA does not regulate, control, approve or disapprove any broadcast, performance or publication of music or any other audio or visual presentation.
- We do not play or perform any music, nor do we offer referrals to anyone who does.

❖ LICENSING INFORMATION

- If the Lessee or an exhibitor wishes to use copyrighted material, it will be necessary for you to make arrangement with the ASCAP, BMI or SESAC for license to perform such copyrighted music or material or otherwise qualify for an exemption.
- The facility retains the right to regulate the volume of any sound, whether it be music, voice, special or artificial effects to the extent that the same interferes with other lessees within the facilities or is determined to be offensive or otherwise violates the terms or the rules and regulations of the lease agreement.
- Please contact the following agencies for more information:

**American Society of Composers,
Authors and Publishers (ASCAP)**
Licensing: (800) 652-7227
General Information: (800) 505-4052

Broadcast Music, Inc. (BMI)
General Information: (800) 925-8451
SESAC
General Information: (800) 826-9996

BUILDING CHECKLIST:

LVCC

Timing	Action
6 Months Out	Submit Proposed Floor Plans
6 Months Out	Approve Hanging Signs and Banners
60 Days Out	Submit Written Plan for Pyrotechnics
60 Days Out	Submit name/contact information for rigging foreman to LVCVA Director of Engineering and Facility Projects
60 Days Out	Submit Traffic Plan
	Submit Helicopter Landing and Skydiving information
30 Days Out	Provide Insurance Certificates
30 Days Out	Submit Detailed Lobby Plans
30 Days Out	Submit List of Exhibitor Appointed Contractors
30 Days Out	Submit Show Security Schedules, Locator Form and Weapons Request Form
30 Days Out	Submit List of Advertising Sold in Public Spaces

Contact your Convention Services Manager for additional information.

CASHMAN CENTER

Timing	Action
60 Days Out	Submit Proposed Floor Plans
60 Days Out	Approve Hanging Signs and Banners
60 Days Out	Submit Written Plan for Pyrotechnics
30 Days Out	Submit Helicopter Landing and Skydiving Information
30 Days Out	Provide Insurance Certificates
30 Days Out	Submit Detailed Lobby Plans
30 Days Out	Submit List of Exhibitor Appointed Contractors
30 Days Out	Submit Show Security Schedules, Locator Form and Weapons Request Form
30 Days Out	Submit Traffic Plan

BUSINESS CENTER

LVCC:

FedEx Office operates 3 business centers conveniently located within the Las Vegas Convention Center. The Business Centers, located near the main entrance of Central Hall, in the Central Hall Concourse and in South Hall near Steampunk Joes, can assist with a variety of services for your event. Services include consultation on signs and graphics, high speed/high volume printing, traditional printing and copying, business cards, posters and banners (including Grand Format printing), fax services, packing and shipping, computer and internet access and an array of office supplies. The Business Center also offers secure storage, Coat and Bag check, Equipment Rental and Scooter Rental. The Business Center near the main entrance of Central Hall also has a Board Room that can be rented out to help facilitate business while at the Las Vegas Convention Center.

A FedEx Office Team Member can consult with you prior to your arrival on property to coordinate all your printing needs in advance of your event. Your printed materials will be conveniently waiting for you at the Las Vegas Convention Center when you arrive for your event.

The Business Center is open 8 a.m.–5 p.m., 7 days a week, however hours are subject to change based on event need. Please contact the FedEx Office Business Center at (702) 733-2898 for additional information. Or visit [FedEx's Website](#) for information and to submit your print projects on line.

CATWALK ACCESS

Individuals or companies requesting catwalk passes need prior approval from show management and the Convention Services Manager.

❖ PROCESS

- Catwalk passes can be obtained from the facility Customer Safety locations:
 - LVCC - Grand Concourse across from Hall C3
 - Cashman Center – Lot C entrance
- You must be 18 years or older to obtain or use a catwalk pass.
- A current driver's license or valid state I.D. will need to be presented before any pass is issued.
- The driver's license/I.D. will remain at Security Dispatch until all passes have been accounted for and turned in to dispatch.
- Catwalk passes are issued and returned on a daily basis.
- Catwalk passes are not transferrable and cannot be loaned to another person.
- All lost passes must be reported. There will be a charge of \$100 for a first time lost pass. A second lost pass by the same individual or company will be charged \$500. The retained identification will be returned upon total accountability of the passes.
- Individuals found in a catwalk area without a current approved pass or in possession of an unauthorized pass will be trespassed from property and may be prosecuted according to Nevada Revised Statutes.

CHEMICALS

- All chemicals brought into the facility must be labeled as required by OSHA and accompanied by the applicable SDS – Safety Data Sheet (Formerly MSDS – Material Safety Data Sheets). It is highly recommended that the SDS be submitted at the time floor plans are submitted.
- A list of chemicals must be included with your booth plan submittal to boothplans@lvcva.com.
- Exhibitors are responsible for supplying show management with all chemical information brought into the facility.
- Arrangements must be made in advance with an outside resource for disposal. Disposal of hazardous materials is prohibited in the sinks, sewer lines or drains of the facility.

CHILD CARE

- Child care facilities shall not be permitted at the facility properties unless Lessee obtains appropriate licensing, permits and inspections from the following Clark County entities:
 - Clark County Child Care Licensing
 - Southern Nevada Health Department
 - Clark County Fire Department

Company must provide insurance in the amount of \$10 million naming the Las Vegas Convention and Visitors Authority as additional insured. Subject to final approval by your Convention Services Manager and Legal Counsel.

DIGITAL ADVERTISING

- The LVCVA is pleased to offer advertising at the Las Vegas Convention Center that can enhance your show and provide an additional revenue opportunity through digital signage ad space. We have partnered with Cox Business to provide this high-tech digital experience throughout our building for our show clients and your exhibitors
- The digital signage network consists of 14 video walls throughout the North, Central and South Hall public areas. Please contact Cox Business for more information Phone: (702) 943-6500.

REMOTELY PILOTED AIRCRAFT SYSTEMS (RPAS)/UNMANNED AERIAL VEHICLES (UAVs)/DRONES GUIDELINES

RPAS/UAVs/Drones are permitted. The following guidelines must be strictly adhered to:

- Exhibitors have approval from show management and your Convention Services Manager (CSM) before flying any RPAS.
- A form must be completed and submitted.
- All Federal Aviation Administration (FAA) and Department of Homeland Security guidelines must be observed.
- RPAS carrying weapons are prohibited.
- RPAS may not be flown in lobbies, restaurants or other common areas.
- RPAS must weigh less than 55 pounds.

❖ EXHIBIT HALLS/MEETING ROOMS/OUTDOORS

- RPAS are restricted to within your defined booth space only.
- RPAS must be flown in a fully enclosed area (including ceiling) using netting, plastic, or other safety measure. Tethering is not an approved safety measure. Netting must be made of material that is sturdy enough to prevent the RPAS from breaking or escaping the enclosure.
- RPAS are prohibited from flying over populated areas.
- RPAS are prohibited from flying within 18" of any building structure including sprinklers.

❖ OUTDOORS

- FAA regulation restrict RPAS from being flown within five (5) nautical miles in class Bravo airspace (McCarran International Airport) and class Delta airspace (North Las Vegas Airport). Due to the proximity to these airports, RPAS's are prohibited from flying outside on any LVCVA campus. Waivers obtained through the FAA must be provided to the Convention Services Manager.

ELEVATORS AND ESCALATORS

❖ PROHIBITED

- Freight is not permitted on passenger elevators.
- The transportation of dollies, oversized luggage, boxes or freight and tool boxes on escalators is prohibited.

❖ FREIGHT ELEVATOR LOCATIONS

- Freight elevators for contractor use are located near freight door 10 and in the west lobby. Freight for the 2nd floor in the south halls must be transported via the south hall ramps.

EMERGENCY SITUATIONS

To report an emergency, please call **(702) 892-7400**.

- Security staff is trained to handle emergency situations. The Customer Safety Office is operational 24 hours a day and becomes the communications center and command post in the event of an emergency.
- The Convention Services Manager is responsible for keeping show management and Official Service Contractors informed of decisions relating to emergency events in progress.
- All emergencies should be reported to the Customer Safety Department first.
- Dialing 911 will delay the response by medical personnel who may not be able to find or get to the location of the emergency.
- Texting program information.

EXCLUSIVES

The LVCVA has three exclusive partners: Centerplate, COX Business and FedEx Office.

EXIT SIGNS

- Building exit signs must be illuminated and visible at all times.
- Exit signs may not be turned off.
- Any drape, exhibit or convention-related material hung or built near an exit sign must be installed so the exit sign is not covered. If an exit sign is blocked from the usual sight line, another emergency exit sign must be temporarily installed with a secondary power source.
- There will be no power interruption to the emergency sockets within an exit sign. The LVCVA emergency power supply will not be used as a secondary power source for temporary signs.

FIREARMS ON DISPLAY

- Any exhibitor displaying firearms at a trade show must contact the Convention Services Manager so approval can be submitted to the Executive Director of Customer Safety.
- The company shipping the firearms to the exhibitor must have a Federal Firearms License.
- All firearms must be disabled by either removing the firing pin or other component to prevent the firing of the weapon.
- Live ammunition is prohibited. Inert or dummy ammunition may be used.
- The exhibitor must contract with a Certified Firearms Expert to inspect and tag the firearms. The tag indicates to everyone viewing the firearm that it has been inspected and is safe.
- During non-exhibit hours, firearms must be secured. Options include: cable lock, locked display cabinet, or by contract security guard. Alternatives must be approved by LVCVA Customer Safety Department.

FOG MACHINES

- Use of all fog machines must be pre-approved by the Fire Prevention Office. A demonstration of the fog machine and its intended use must be given to the fire prevention office at least 48 hours in advance.
- The fog machine must be UL listed or equivalent (for its intended use) and it must be in good repair.
- The fog-generating fluids must be water-based and stored in the original containers that were provided by the manufacturer. Substitute containers or un-marked containers will result in denial of the use of the fog machine(s).
- The Safety Data Sheet (SDS) for the fog fluid must be sent to the fire prevention office for approval in advance of the event move-in.
- The SDS sheet must remain in the booth/event location at all times.
- The facility reserves the right to limit the amount of haze produced by a show.

GREEN INITIATIVES

- The Las Vegas Convention & Visitors Authority (LVCVA) is committed to building on our current successes and maintaining a proactive approach towards future sustainable activities such as recycling, green purchasing, education, and conservation programs. [Read more about our Sustainable Initiatives here.](#)

HEAVY EQUIPMENT PROCEDURES

Show management must provide the facility a list and obtain approval for all equipment weighing over 250,000 lbs. A site plan is required showing locations of each piece of heavy equipment.

❖ FLOOR LOAD LIMITS

- Heavy equipment being brought into Halls S3, S4, C3, C3 Concourse, and C4, may require advance review and approval by a structural engineering firm at the expense of show management and/or the exhibitor.
- The floor weight load limit for Halls S3-S4 is 300 pounds per square foot. Halls C3, C3 Concourse and C4 have weight restrictions in designated areas. Please contact your Convention Services Manager for additional information.

❖ MOVEMENT OF EQUIPMENT

- Equipment with smooth tracks over 250,000 lbs. must be moved on one-inch plywood outside and inside of building
- Equipment with cleated tracks over 250,000 lbs. must be moved on one-inch steel plates outside and inside of building.
- LVCC/Cashman Center personnel must be present in either case. Meetings must take place between the facility and the general contractor to determine routes and method of movement.

HELICOPTERS

- Lessee or exhibitors requiring helicopter usage on LVCVA premises shall provide insurance coverage of \$10 million Aircraft Liability including passenger liability.
 - *A Certificate of Insurance naming the Las Vegas Convention and Visitors Authority as additional insured must be provided thirty (30) days prior to the use of the facility for landing a helicopter.*

[Complete a Helicopter Landing Request Form.](#)

- Shows do not require additional permits to land in one of the designated areas noted below; however, Clark County Fire Department (CCFD) must be notified of your intent to land a helicopter on our property:
 - LVCC, Blue lot 1
 - LVCC, Silver lots 1 & 2
 - LVCC, Orange lots 1 & 2
- CASHMAN:
 - Helicopter landings at Cashman Center require a permit from the Las Vegas Fire Department. LVCVA will obtain this permit, but Show Management or the Exhibitor must provide the CSM with a written plan including landing and take-off frequency, times and locations. Exhibitor and/or Show Management will work with the CSM and Fire Prevention to determine acceptable landing zones.
- Air traffic control communication must be established with the local airports for both take-offs and landings.
- Appropriate fire extinguishing and grounding equipment must be supplied and maintained while the aircraft is on property.
- A windsock will be provided the LVCVA in designated lots as needed.

INDOOR AIR QUALITY

- All forklift trucks, platform lifts, boom lifts and other motorized equipment utilized for the move-in and move-out of events shall utilize cleaner burner alternative fuel than gasoline. The alternative fuel shall be electric, natural gas, and/or propane fuel. All refueling, changing of propane/natural gas bottle/containers or recharging of these vehicles must be conducted outside the facility.
 - Propane cylinders awaiting use shall be stored in a secured propane storage cage that meets the requirements of OSHA. Storage cages must be secured in a location selected by LVCVA staff outside of the building.
- Any vehicles that are utilized to deliver freight directly into the facility for move-in or move-out shall turn the vehicle off upon arriving at the final location. No vehicle shall be allowed to sit and idle in the facility.
- The use of any special equipment (such as cranes, large lift trucks, etc.) in the facility for move-in and move-out shall be coordinated with the Convention Services Manager 30 days in advance, so provisions can be made to ensure proper ventilation is maintained. If the existing ventilation system cannot provide adequate air exchanges, the Official Service Contractor shall provide means of ventilation at their expense.
- All equipment utilized for move-in and move-out shall be kept in compliance with all governing laws and regulations at all times.

JANITORIAL AND CLEANING SERVICE

- Lessee will receive the leased area in a clean state and is required to return the leased area in the same condition (i.e., trash and floor tape removed).
- The facility will clean public areas, meeting rooms and rest rooms during the leased period.

- Areas used for exhibits, general sessions (exhibit halls), including parking lots, show offices, registration areas or meeting rooms used for storage or work rooms are the responsibility of the Lessee.
- All other janitorial and cleaning service, through move-in, show and move-out is the responsibility of the Lessee. All cleaning materials/equipment must be stored in an approved area.
- Excessive cleaning and trash removal will result in an additional cost to be invoiced to Lessee. Any building damages incurred will be repaired and labor/materials invoiced to Lessee.

KEYS CARDS/ACCESS LOCKS

- If you require meeting room keys, please submit your request to your Convention Services Manager prior to your event dates.
- Each unreturned metal key will be charged back to you at \$20.00 per lost key. There will be no charge for unreturned key cards.
- Please note that the LVCVA assumes no responsibility for any items left in the meeting rooms regardless if locks have been changed or if keys have been issued to Show Management. You may consider contracting with your security company to ensure the security of these rooms.

LOBBIES

LVCC – Exhibit Hall Lobbies are not leased space and must always be kept open for public access and used within certain guidelines set forth by the LVCVA.

Cashman Center – Meeting Room Lobbies & Exhibit Hall Corridors are not leased space and must always be kept open for public access and used within certain guidelines set forth by the LVCVA.

❖ GUIDELINES

- No carpet or flooring may be placed on the existing carpet in the lobbies or public areas without prior approval from your Convention Services Manager. If carpet or flooring is approved to cover the existing carpet, visqueen must be laid between the building carpet and the carpet being installed. Use only non-residue tape. All carpet must be pre-cut, cutting is not allowed over building carpet.
- Electric carts and bicycles may not be used on any carpeted area in the LVCC/Cashman Center unless visqueen is placed on the carpet.
- Carts/forklifts are not allowed on the second floor of the LVCC.
- Neon signs may not be covered or turned off without the permission of the Convention Services manager.
- LVCVA management reserves the right to determine areas to be used by each show and resolve any conflicts in the event the lobbies/plazas are to be shared by two or more shows.
- To accommodate the comfort of attendees, the LVCVA will configure seating in all lobbies and public areas one (1) day prior to show opening. The location and arrangement of seating will be at the discretion of LVCVA management and will remain as configured for the entirety of the show.

LVCVA EMPLOYEE ACCESS

- The Convention Services Manager will work with show management to allow access to leased space to LVCVA personnel in order for them to perform their work-related duties.

MARQUEE

Cashman Center

- Announcements on the marquee, located on Las Vegas Blvd. North must contain a client contact phone number or website address.
- Lessee is allowed one (1) complimentary message per cycle on the message center.
- Outdoor messages are programmed to be displayed one (1) week prior to the event.

MESSAGE SERVICES

Message Services are not permitted within the public (unleased) space. They are permitted within space that is leased to the show.

MONORAIL – LIMITS OF APPROACH

If a client is leasing space in the parking lots or utilizing other outdoor space, the Convention Services Manager must be apprised of plans for these areas. There are established “Limits of Approach” with respect to the area surrounding the monorail system. To ensure a safe working environment, work within this area is not permitted without prior approval.

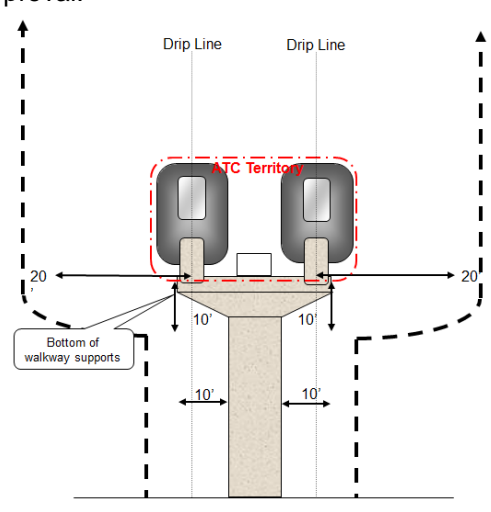

THE LIMITS OF APPROACH ARE DEFINED AS FOLLOWS:

- Within 10 feet horizontally of a monorail column, from ground level up to a distance of 10 feet vertically down from the bottom of the walkway supports that run the length of the guide way,
OR
- Within 20 feet horizontally of a Las Vegas Monorail Station or the drip line on the monorail guide beam from a height of 10 feet below the bottom of the walkway supports upwards. The drip line is the line that extends through the center of the monorail guide beam into the dynamic envelope of the Automatic Train Control (ATC) Territory. The area of concern extends from the ground up to and beyond the guide way due to the danger of objects falling into Automatic Train Control (ATC) Territory from above.

OUTDOOR EXHIBITS

❖ **RULES AND REGULATIONS**

- Parking lots used for exhibits that will have tents, pavilions, trailers or sprung structures must have 24-foot aisle for fire and emergency vehicle access.
- Outdoor exhibits must have an approved floor plan. Booths that have tents, pavilions, trailers or sprung structures must be on a 10-foot wide aisle.
- Temporary restroom facilities may be required for outdoor exhibits.
- When parking lots are used for outdoor exhibits, the lessee will be charged back for the cost of open trash boxes and if they are ordered through the facility.
- Use of water from LVCC hydrant requires an in-line meter with usage readings.
- Any **Temporary Assembly Structures**, (structures that have either membrane or solid hard shell or glass) sides that exceed 4,500 square feet have additional requirements set by Clark County, please click [here](#) for Clark County requirements for temporary structures outdoors.
- All banner material used outside must be made of mesh material (a minimum of 30% pass through) or slatted to allow for air to flow through.
- The use of pipe and drape, MIS or gem wall units outdoors must have advanced approval from the CSM. However, pipe and drape, MIS or gem wall units is allowed to be used inside fully enclosed structures.
- Installation and dismantling of tower cranes require a 300-foot clear zone. We recommend that tower cranes not be installed within 300 feet of Desert Inn Road and Paradise Road (LVCC).
- Tower cranes need FAA approval.

- If pouring a sub-floor made of concrete onto the asphalt, visqueen must be used under the pour and the surrounding area. Bonding agents are prohibited.
- Reference Food Preparation within Exhibits for information on exhibition and display cooking.
- Reference Fire and Safety Exhibit Guidelines for information on propane usage and storage.
- Any fuel storage greater than 10 gallons of gasoline or 60 gallons of diesel on property will require a [Clark County Permit](#).
- LVCVA management reserves the right to make any changes on site that is deemed necessary without advanced notice, for safety concerns.

❖ TENTS AND CANOPIES

All outdoor tents and/or temporary structures must be installed by facility approved Exhibitor Appointed Contractors (EAC) and must submit and receive an approved staking plan before staking can occur. Staking plans should be submitted 30 days prior to conventionservices@lvcva.com

- All Tents (a structure that is covered with a soft top and soft sides) greater than 400 square feet require a Clark County Permit. Must also have a 2A40BC Fire Extinguisher that has a current Nevada State inspection tag.
- All Canopies (covered with a soft top but no sides) greater than 700 square feet require a Clark County Permit. They must also have a 2A40BC Fire Extinguisher that has a current Nevada State inspection tag.
- Self-installed pop-up canopies require either weights or stakes, must be lowered every evening at close of show, and depending on weather conditions, may need to be taken down – to be determined by facility on site.

❖ STAKING

- All staking needs to be drilled, no hand staking is permitted.
- Anchoring or staking into concrete is prohibited property wide.
- Trenching or digging is not allowed into the asphalt without the prior approval from a CSM, please contact conventionservices@lvcva.com for approval.
- Final on-site staking approval must be obtained by a member of the LVCVA exterior engineers or engineering management before any drilling and staking may begin.
- The asphalt must be returned back to its original condition. LVCVA standards are:
 - Back fill existing hole(s) with clean, fine type sand. Tamp to within 4" minimum of grade surface.
 - Fill rest of hole(s) within ½" of surface with fine aggregate type patching asphalt tamp until solid.
 - Cover areas approximately 2" around patched hole with a good grade of plastic type asphalt sealer with a maximum drying time of 2 hours.

❖ TRUSS STRUCTURES

- All truss structures require plans to be submitted to Fire Prevention 90 days in advance and must meet American National Standards Institute (ANSI) regulations E-1.21. Depending on size, attachments and weight, facility may require a 3rd party engineer stamp of approval. The engineer stamp of approval must include wind load and seismic load. This will be at the exhibitor's expense. Please send to boothplans@lvcva.com
- If an exhibitor has their own ballast (weight) but it is deemed insufficient by the facility, they must procure additional ballast from a local source and/or the show's general contractor at their own expense.

PAGING

- Show paging is available for all of the exhibit halls.
- The LVCVA will provide a mixer and microphone and place where specified by show management, either on the show floor or in a meeting room.

- If the location for show paging on the show floor is not near available power, show management will need to provide an electrical drop.

PERSONAL MOBILITY DEVICES

The use of Segway's, skateboards, hover boards, in-line skates, roller skates, scooters (either motorized or foot-powered) are not permitted on facility property(s). This includes all non-ADA approved mobility devices.

ROOF ACCESS

- All persons requiring roof access must obtain approval in advance. To do so, submit roof access form to conventionservices@lvcva.com.
- Once written approval has been given, go to the Engineering Department on the specified installation date to complete the process. Anyone requiring a roof pass on the weekend must go to Security.
- Roof access times are Monday – Friday, 7:30 am – 4:30 pm, (winter hours may vary due to weather conditions and day light savings time). Engineering will need 24 hours' notice for scheduling roof access.
- Engineering staff will escort persons desiring roof access and monitor roof activity.
- Items placed on the roof must have the contractor's name, booth number and show name.
- Persons accessing the roof without a pass will be trespassed.
- Access to the roof areas via lift is prohibited.
- Fall protection must be used when required by OSHA.
- Foot traffic over roof surfaces must be via mats where provided.
- Penetration of the roof surface is prohibited.
- Any items, such as wiring, satellite dishes, etc., placed on the roof for a show, must be placed on designated platforms. Equipment must be removed during move-out of show.
- Individuals blocking or taping open any roof access doors will be trespassed from property.

❖ EQUIPMENT INSTALLATION

- Satellite pads are available on the roof of Halls C1-C5, N1-N4, and S3-S4 (LVCC). Any contractor or exhibitor requiring access to roof must first obtain permission from show management and the Convention Services Manager as well as obtain a roof access and catwalk pass.
- Roof access passes expire at the end of each day. No work is permitted on the roof during inclement weather. No work is permitted on the roof after 5:00 p.m. All roof hatches will be secured at this time
- Cox Business has exclusive rights for all cable runs.
- All satellite dishes must be placed on a ¾" carpeted piece of plywood.
- Equipment can only be mounted on roof platforms, not on any other roof surface.
- The mounting of equipment on antenna masts is permissible where available. Contact your Convention Services Manager for further information.
- Roof walkways must be used when available.
- Satellite dish size is restricted to one meter (39 inches) with no exceptions.
- Installer is responsible for removal of satellite and any debris after the show or event concludes.

❖ PROHIBITED

- The use of sandbags or cinder blocks is prohibited.
- Cable may not be laid through roof hatches.
- Aluminum clad Flooded Jacked Cable is not permitted.

SATELLITE/ANTENNA INSTALLATION (refer to roof access)

SECURITY STANDARDS PROGRAM

- The LVCVA Minimum Security Program establishes standards for the assignment and performance of contract security companies operating on LVCVA property. The minimum standards assure that all events occurring on LVCVA property are conducted in a safe and secure environment.

- Clients are encouraged to communicate with the LVCVA Customer Safety Department as early as possible before the event to ensure ample time is allotted for the preparation of a comprehensive security plan. Phone: (702) 892-7407

SERVICES

The Las Vegas Convention Center offers a spectrum of high quality services complimenting its convention and meeting facilities. With full service kitchen facilities, two restaurants with seating for over 1,300, 18 concession stands, and one Starbucks cafe, every culinary need can be met with a taste of Las Vegas. Event services include a master antenna system, local, cable and closed circuit television. Registration services operated on a fee basis; and badges and badge holders available upon request. Complimentary wireless Internet access is available in all common areas and meeting rooms.



SHIPPING AND RECEIVING OF EXHIBITOR MATERIALS/PRODUCTS

- Your Official Service Contractor will handle the shipping and receiving of all goods to the LVCC/Cashman Center.
- Please note that the facility is unable to accept any goods shipped to the facility for Show Management or any exhibiting company.

SKY BRIDGE LIGHTBOX ADVERTISING

Lightbox advertising includes five (5) backlit displays located on the sky bridge that connects Westgate to the Las Vegas Convention Center.

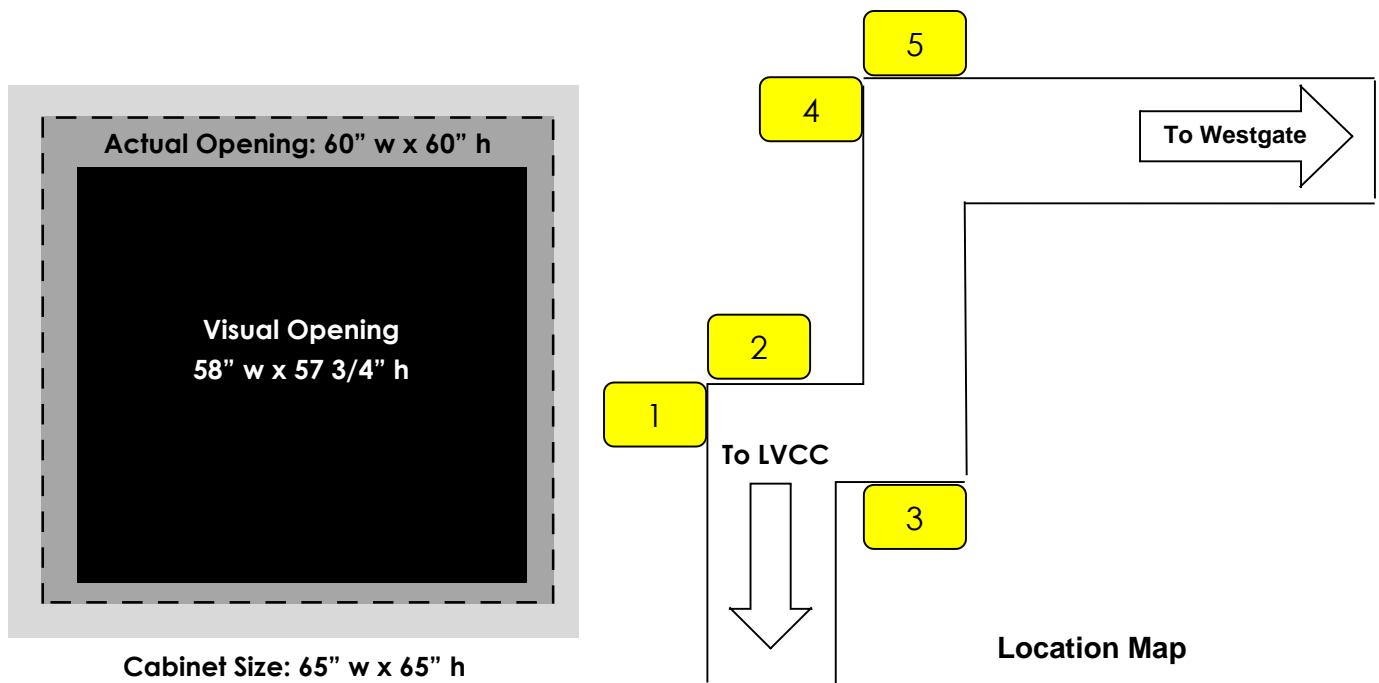

Production requirements for lightbox graphics include a professionally produced material used for backlit display boxes. Event producers may use any production vendor of their choice, as long as appropriate materials are utilized in the production of the graphics. It is the responsibility of the Lessee to work directly with a qualified printer for artwork submission, deadlines and payment of graphics. The event producer is responsible for the payment of the standard 15% commission to the Las Vegas Convention Center for public area advertising as specified in their lease.

LVCVA Sign Shop staff will coordinate insertion and removal of the graphics into the lightboxes pre-and-post show. If graphics are to be returned to the event producer, please ensure specific instructions are provided. Standard practice will be to remove and discard all graphic materials after completion of show, unless otherwise instructed.

Lightbox Specifications:

Cabinet Size: 65" w x 65" h
Actual Opening Size: 60" w x 60" h
Visual Opening Size: 58" w x 57 3/4" h

Completed Graphic Signs Delivery Information:

LVCVA
Attn: Sign Shop
3150 Paradise Road
Las Vegas, NV 89109
(702) 892-0711

Please include your show name AND show dates on delivery information. Lessee must give the LVCVA Sign Shop at least 5 business days for installation of their graphic signs.

Please contact your contractor for a list of available areas and qualified printers.

SKY DIVING

- Any lessee or exhibitor wishing to have a sky diving exhibition must have the approval of the Convention Services Manager thirty (30) days prior to proposed event.
- All jumps must be pre-approved by the FAA and proof of approval provided to the Convention Services Manager.

- Lessee, exhibitor, and skydiving company or companies must provide insurance coverage of \$5 million naming the Las Vegas Convention and Visitors Authority, Lessee, and exhibitor as additional insured.
- Any approved jump must meet all existing LVCVA policies and procedures for such activity.

SOUND LEVELS

- The Las Vegas Convention Center retains the right to regulate the volume of any sound, whether it be music, voice, special or artificial effects to the extent that the same interferes with other lessees within the facilities or is determined to be offensive or otherwise violates the terms of the lease agreement and the building policies.

TRANSPORTATION & TRAFFIC PLANS

- Please forward the following traffic plan information to your Convention Services Manager for approval at least sixty (60) days prior to your first move-in day:

▪ Name of transportation company	▪ Schedule of shuttle service
▪ Number of routes	▪ Any special requirements
▪ Number and destination of buses	▪ Any ADA transportation information
▪ On-site contact name and telephone number	▪ Any potential challenges
▪ Location of bus staging	▪ Las Vegas Metropolitan Police traffic control schedule

- If you anticipate heavy or unusual vehicle traffic during your show, contact your CSM.
- Out of state limousine/transportation companies may not operate without a valid Nevada license and permit.
- TNC's (Transportation Network Companies) who have an exclusive with a show may not distribute, advertise, or place signage anywhere on Authority property other than leased space.

❖ OVERSIZE/OVERWEIGHT VEHICLES AND LOADS

- The State of Nevada requires special truck permits to move exceptionally large or heavy loads on all roads throughout the State, including those into and out of the facility.
- You may have logistical issues if you need to bring in any single item, vehicle, piece of equipment, building, etc. that, either self-propelled, towed or trailered, is wider than 8'6", taller than 14', longer than 70', has more than 10' of overhang, or weighs more than 80,000 pounds.
- These loads and other unregistered vehicles such as airplanes, floats, boats, mobile/manufactured homes and buildings will require special planning and routing arrangements. In any case, this can be a costly affair, so plan early and contact a reliable heavy transporter at least 90 days in advance of any required movement. The transporter will coordinate with the appropriate authorities: State permits, city traffic, utilities, pilot escorts, and law enforcement.
- For more information, contact Nevada DOT Over Dimensional Vehicle Permits Office at (800) 552-2127 or visit their website at [Nevada Department of Transportation](http://www.nv.gov/transportation).

UNION AND NON-UNION LABOR DISPUTES

- It is the responsibility of the trade show general contractor to resolve all jurisdictional disputes. Union contracts contain dispute resolution procedures and all involved parties must follow them. Work now, grieve later.
- Threats to or illegal confrontations with exhibitors or show management will not be tolerated. Individuals involved in threats or illegal confrontations with exhibitors, show management, other workers, or LVCVA personnel may be issued a Trespass Notice and escorted from the Las Vegas Convention Center. If any information is received, or incidents observed, notify the LVCVA Customer Safety Department at telephone number (702) 892-7400.

VEHICLES

- Fuel tank openings shall be locked or sealed in an approved manner to prevent escape of vapors.
- Fuel tanks shall not contain more than one-quarter their capacity or more than five gallons of fuel, whichever is less.
- Batteries must be disconnected.
- Auxiliary batteries not connected to engine starting system may be left connected.
- Electric and hybrid vehicles shall have their operating batteries disconnected whenever possible.
- External power is recommended for demonstration purposes.
- Battery charging is not permitted inside the building.
- Combustible/flammable materials must not be stored beneath display vehicles.
- Fueling or de-fueling of vehicles is prohibited
- Vehicles shall not be moved during the show and will remain off while freight doors are closed.
- 36" of clear access or aisles must be maintained around the vehicle.
- Vehicles must be a minimum of 20 feet from exit of door or exit pathway.
- Vehicles placed in lobbies and meeting rooms must have approval of the CSM and require leak protection.

WEAPONS

- A personal or concealed weapon of any type are not permitted
 - Nevada Revised Statute 202.3673 prohibits concealed weapons of any type on facility property(s).

EXHIBITION AND MEETING SPACE

Please visit the [LVCVA website](#) for capacity details and floor plans for all meeting rooms and exhibit halls.

MEETING ROOMS

- Carpeting can be placed on top of building carpet in the meeting rooms with permission from the Convention Services Manager. Visqueen must be laid between the building carpet and the carpet being installed. Use only non-residue tape. No sub-flooring is allowed for exhibits.
- When moving freight or equipment in these areas the existing carpet must be protected by the use of approved runners or visqueen. Forklifts, electric carts, etc. are not permitted on the second floor. All freight and materials must be moved via pallet jack or hand cart
- Exhibitor crates and pallets must be placed on rollers or visqueen.
- No signs, banners, trussing, lights, etc., may be hung from the ceilings or the support structures above the ceilings.
- Nothing may be affixed to meeting room walls or doors without approval of the Convention Services Manager.
- No structures erected in these rooms may have any type of ceiling. All walls must be 18 inches below automatic fire sprinkler heads.
- When constructing any wall units, care must be used not to obstruct any of the HVAC controls, light controls, electrical outlets, cable TV outlets, sound outlets, fire extinguishers, exit signs or exits.
- All exhibits being set in these rooms must have an approved floor plan. These floor plans must be submitted to the LVCVA Convention Services Manager at least 60 days in advance of set up.
- Anyone in the process of designing exhibits or displays for these meeting rooms are encouraged to contact the Convention Services Manager for clarification of all rules and regulations.
- Closet and utility rooms are not included with any meeting room. These are for LVCVA use only.
- Meeting room air walls will be moved only by LVCVA personnel. Air walls must be configured prior to laying carpet over building carpet. Contact your Convention Services Manager if you need assistance.
- Installation of flooring and trussing is only permitted with approval from the Convention Services Manager
- Events in second floor meeting rooms involving mass or group rhythmic activities must have advance approval. Contact your Convention Services Manager for further information.

❖ **MEETING ROOM EQUIPMENT (provided)**

- When multiple shows are scheduled, equipment is available to the extent of inventory that is shared between all shows.
- When extensive building equipment is being utilized (i.e. large general session, multiple max room sets) production schedule needs to be discussed with the CSM for appropriate labor scheduling/
- Cables and wires must be routed above doorways; not across the threshold.

BLEACHERS

Bleachers are available for a fee. Please contact your Convention Services Manager for details.

CHAIRS

Chairs are the gray stacking type and available for meeting room sets to the extent of our inventory. At the base, chairs are 20 x 20 inches.

EASELS

The LVCVA provides easels to the extent of our inventory. Note: Easels are not the type that will hold a flip chart.

LECTERNS

Standing lecterns are provided free of charge to the extent of our inventory.

MICROPHONES

The LVCVA will provide wired microphones including podium/microphones, lavalieres, aisle, and table microphones at no charge to the extent of LVCVA inventory. All wireless microphones must be supplied by an A/V contractor.

RISERS

The LVCVA sets panels for a stage/dais if required. Panels are 4' x 8' and are available in heights of 16", 24", and 32". The next size ranges from 36" to 48" in two inch increments. The platform is two-sided. One side is carpet in a multi-pattern of black, gray and white. The other side is black vinyl. All skirting is black. The LVCVA will utilize to the extent of the inventory. According to code, side and back rails are required for stages above 32".

TABLES

Table sizes are 18" x 8', 30" x 8', and 6' rounds, all 30" high. The tops are gray and are hard plastic. They do not come draped or skirted.

❖ **MEETING ROOM EQUIPMENT (NOT provided)**

DRAPED/SKIRTED TABLES

If a draped head table or skirted table is required, it must be ordered from the official service contractor. The LVCVA has plastic tables, and they cannot be draped, as there is no way to staple into them. The LVCVA does not provide linens or skirting.

AUDIO/VISUAL EQUIPMENT

All projectors, screens, DVDs, laptops, etc., are ordered through the audio/visual contractor. Four line inputs may be set in one room without a sound operator. A fifth input requires an operator which must be ordered from the audio/visual contractor.

FLIP CHARTS/MARKERS/POINTERS

Flip charts, markers, and pointers must be obtained from the audio/visual contractor.

PADS/PENCILS

The LVCVA does not provide pads or pencils.

PIPE/DRAPE

The LVCVA does not provide pipe and drape.

COCKTAIL TABLES

The LVCVA does not provide cocktail tables/high boys.

ADDITIONAL PLANNING NOTES

- Each meeting room is allowed one (1) no-charge setup per day. Check with the Convention Services Manager for multiple setup fees.

SHOW POWER IN MEETING ROOMS

- Electrical service is limited to installed plugs/Crouse-Hinds show power receptacles in each room. (See below for listing of available show power.)

Room #	Show Power Plugs, 208V/3Ph	Other Show Power Connection, 208V/3Ph
C102-C107	NONE	
C201-C206	NONE	
N101 - N103	60 Amp	
N104 / 105 / 106	NONE	
N107 - N110	60 Amp	
N111	60 Amp	125 Amp
N112	60 Amp	100 Amp
N113 - N117	60 Amp	
N118	NONE	
N119 - N120	60 Amp	
N201	60 Amp	100 Amp
N202 - N210	60 Amp	
N211	60 Amp	100 Amp
N212 - N218	60 Amp	
N219	60 Amp	100 Amp
N220 - N228	60 Amp	
N229	60 Amp	100 Amp
N230 -N231	60 Amp	
N232	60 Amp	60 Amp
N233 - N245	60 Amp	
N246	60 Amp	200 Amp
N247 - N249	60 Amp	
N250	60 Amp	60 Amp
N251	60 Amp	
N252	4 – twistlock 20 Amp	
N2533	4 – twistlock 20 Amp	100 Amp Camlock
N254 - N255	4 – twistlock 20 Amp	
N256	4 – twistlock 20 Amp	100 Amp Camlock
N257 - N259	4 – twistlock 20 Amp	
N260 - N261	4 – twistlock 20 Amp	100 Amp Camlock
N262 - N263	4 – twistlock 20 Amp	
N263C	NONE	
N264	4 – twistlock 20 Amp	100 Amp Camlock
Dmd 1- Dmd 4	NONE	
S101 - S118	60 Amp	
S201 - S218	60 Amp	
S219 - S220		100 Amp Camlock
S221	60 Amp	
S222 - S223		100 Amp Camlock
S224 - S233	60 Amp	

OFFICIAL SERVICE CONTRACTOR RULES AND POLICIES

BADGES/CONTRACTOR PHOTO IDENTIFICATION

The Las Vegas Convention and Visitors Authority (LVCVA) is a participant in the ESCA Exhibition Industry Worker Identification System (WIS) Badge. This identification badge system allows the LVCVA to improve the overall security of our facilities, their licensees and guests.

Everyone in the hospitality industry should be aware of who has access to their facility and space at all times. This is why all Exhibitor Appointed Contractors (e.g. contractors, suppliers and vendors) who work on-site at the Las Vegas Convention Center and Cashman Center must be identified with the WIS badge on their person. **Please note the following exception: At this time, all trade union workers are temporarily exempt from obtaining the WIS Badge. Permanent exceptions include all contract security employees and LVCVA building partners – Centerplate, COX Business and FedEx.**

Show staff, exhibitors and attendees will continue to use the show-issued credential.

The Exhibition Services & Contractors Association (ESCA) has been retained by the LVCVA to administer this program and to maintain an online database of all registered contractors and workers in the local exhibition industry. We recommend companies go online to www.ESCA.org for a complete overview of the process involved in registering for the badges. The WIS Badge is a completely web-based program designed for contractors to order employee badges.

WIS Badge Pricing:

ESCA Member (Full-Time Employees)	\$18.00	Temporary Access Badges (ESCA Member)	\$10.00
All Others	\$25.00	Temporary Access Badges (All Others)	\$13.00

Should any difficulties be encountered with obtaining an Administrator USER ID and PASSWORD, Mitt Arnaudet, WIS National Administrator, ESCA Member Services Director may be contacted to provide additional assistance regarding the process at (972) 447-8210 or by email: mitt@esca.org.

ESCA-WIS Identification Badge



PLEASE NOTE: The WIS badge does not grant the bearer access to any events in any venues. The badge merely verifies that the individual is approved to enter the venue if they are being employed by a contractor working on the specific event. Security for specific events is still in force and all workers must be cleared to enter the events via the normal security protocol in effect for the specific events and venues.

BIKE/CART POLICY

All bikes and carts operated on LVCC/Cashman Center LVCVA property must be registered annually with the LVCVA Customer Safety Department. Included in the registration process is an annual safety inspection which will be completed at time of registration.

ANNUAL REGISTRATION AND INSPECTION

- Bike/carts can be registered at any time and permits are valid from January 1st through December 31st each year. The annual fee is \$10.00.
- Registered carts will be issued a permit which will be conspicuously mounted near the ignition of the cart or the main frame of the bicycle.
- All bike/carts will be safety inspected at time of registration. The following are the requirements all vehicles must adhere to while operating on LVCC/Cashman Center property:
 - Carts – Name of company operating cart must be prominently displayed on cart.
 - Carts – Must have functional headlight, taillight, horn, brakes, and locking on/off switch.
 - Bicycle permits are registered to companies only, not individuals.
 - Bicycles – Must have a mounted red flag at least 8” x 8” visible at least four (4) feet above the seat and reflectors visible from the front and rear.
- Companies which are approved to operate on LVCVA properties and are listed on the Exhibitor Appointed Contractor listing (EAC) may register/operate up to three (3) 3-wheeled carts per company. This limit does not apply to on-site, show specific general contractors.

CART CHARGING

- Charging of Electric Carts:
 - Cart charging location will be designated by LVCC/Cashman Center management.
 - Cart charging inside the building is prohibited.
 - Use of extension cords from inside building to vehicles is prohibited.

PROHIBITED/RESTRICTIONS

- Cart and bicycle traffic during events in the building may be restricted to certain areas and times. Areas of high pedestrian traffic should be avoided.
- **LVCC ONLY:** Carts and forklifts are not to be used on the West side of Diamond Parking Lot sidewalk adjacent to Las Vegas Boulevard.
- At no time are carts permitted to enter parking lots that are designated for vehicle parking. Parking lots can be accessed only when designated as exhibit space.
- No bicycles/carts are allowed on carpeted second floor areas.
- Carts/bicycles are prohibited from blocking entrances to buildings, stairways, handicapped ramps or main thoroughfares.
- Use of electric carts on carpet is permitted only when carpet is protected by reinforced visqueen.
- While operating a cart or bicycle, cellular phone usage is prohibited.

SAFETY

- Reporting of Accidents/Incidents – Accidents involving any carts/bicycles must be reported immediately to the LVCVA Customer Safety Department at (702) 892-7400.
- Bicycles and carts are to be operated in a safe manner at all times.
 - General – Bike/carts shall not be operated in a manner that may endanger passengers or other individuals or cause damage or harm to the LVCVA property.
 - Speed limits – Operators shall not exceed speed limits for motorized vehicles. Operators must reduce speed while making turns and during inclement weather conditions. In crowded pedestrian area, operators must park or proceed at a slow walking pace. Reduce speed when turning, crossing slopes, or when on bumpy, wet or soft surfaces.
 - Passenger Limit and Load Capacity – Do not exceed the passenger limit and load capacity designated by the vehicle’s manufacturer.

- Passenger Safety – Passengers must keep their head, legs and arms within the cab.
- Carrying Cargo – Cargo must not extend more than one foot from either side of the front. Cargo that extends more than three feet from the rear of the cart must be flagged with a bright colored material. All cargo must be secured.
- Roadway – Direction of travel, speed limits, flow of vehicle traffic and all roadway signage must be adhered to at all times.
- Bike/cart operators failing to follow LVCVA Building Rules and Regulations may be asked to surrender the Bike/Cart permit and operators may be subject to trespass.

Bike/cart operators are responsible for complying with this policy and all other state and local laws pertaining to the use of bicycles/carts.

OFFICIAL SERVICE CONTRACTOR RULES AND POLICIES

BUILDING DAMAGE

- Official Service Contractors are billed at \$.002 of the total gross square footage of all exhibit halls and meeting rooms leased for exhibits. This fee is used to cover minor building damage that occurs during a trade show or convention.
 - Prior to the event, Show Management and the Official Service Contractor will be afforded the opportunity to inspect the leased space to identify any existing damage. During or immediately following an event, damage reports will be made for each occurrence of damage sustained. Damage of incidental nature will be covered under the above assessment with no further charges due. Damage exceeding a cost of **\$1,000** will be deemed as substantial. Any damage incurred of a substantial nature will be invoiced to the Official Service Contractor at the current time and materials rate.
 - The Official Service Contractor's Account Executive, the LVCVA Convention Services Manager and the Director of Engineering/Facility Operations will review any reports of substantial damage prior to invoicing. Substantial damage that can be associated with an EAC will be invoiced to that company.
 - In the event of a dispute, Show Management and the Official Service Contractor will meet with the Senior Director of Convention Services and the Director of Engineering/Facility Operations. Mutual agreement will be reached to the satisfaction of all parties

CLEANING

- A clean building is provided at move-in unless arrangements are made between the Official Service Contractor and the building for an early move-in. If this is done, it is the responsibility of the Official Service Contractor making the request to make sure the building is returned clean. This includes all stairwells, parking lots, roads and catwalks utilized by the Official Service Contractor and show.
 - Your cleaning personnel must be on site on the first day of move-in through the last day of move-out.
 - **LVCC Only:**
 - The LVCVA provides compactors. They are placed around the building, at freight doors 4, 7, 15, 24, 26, 35, and 40. Your personnel will pick up the trash in the hall and take it to those compactors. When full, LVCVA Client Services personnel will call the compactor in to be emptied by Republic Services. All compactors are self-dumping with ramps. The compactor bays of all compactors utilized during any phase of show activity must be cleaned and clear of debris as each one is changed out and on the last day of move-out. Failure to do so may result in an additional fee.
 - All cardboard boxes must be broken down when placed in the compactors. Cleaning companies should order open trash dumpsters for those shows having heavy cardboard trash (i.e., a furniture show) as the cardboard will fill the compactor too fast and there will be delays due to the ordering of the change out of the compactor.
 - All wood (pallets, display materials, etc.) is to be placed in designated bulk trash areas. At a minimum, bulk trash must be removed on the first show day and on the final day of move-out. It is your responsibility to have bulk trash removed from our property.
 - When cleaning, during move-in and move-out, no piles of trash may be left in the building overnight.

- Orange Lot 1 (the freight and staging area), the docks by Doors 7 and 8, the North Road (doors 15 through 24), South Hall Doors 26-35, Red Lot dock doors 36-40 and South Hall second level truck dock doors 43-52 must be kept clean and free of debris during move-in, show, and move-out.
- Parking lots or other external areas used for exhibits are to be cleaned and maintained by cleaning contractor.
- Areas around all freight doors should be checked to make sure all pallets and miscellaneous items are removed prior to show opening and during move-out.
- The tracks of the freight doors are to be cleaned out each night.
- Gas powered vacuums are not allowed inside the building without permission from the Fire Prevention Office.
- LVCVA Client Services personnel clean common use areas, i.e., rest rooms, hallways of meeting rooms and meeting rooms when used for meetings. The LVCVA does not clean meeting rooms or the hallways when area is utilized for exhibits or when the rooms are used as offices, store rooms, or by the Official Service Contractor. Your personnel must pick up exhibitor material in hallways. We do not clean behind the registration counters.
- The LVCVA provides 40-gallon waste containers, upon show management approval, throughout the exhibit hall on the first day of the show, but it is your responsibility to empty and replace the liners. It is recommended that clear liners be utilized.
- All items must be removed from building, including discarded booth furniture that the clients have left behind. All left over publications must be removed.
- All tape and residue must be removed from the floors during move-out. Clear tape is not to be used on exhibit hall floors.
- Trash must be removed from behind draped areas.
- All residues must be removed from glass/windows both internal and external if unauthorized or poor quality materials are used.
- Paint spills, hydraulic leaks, **medical waste** or anything of this nature should be handled immediately by the Official Service Contractor/cleaning contractor.
- It is the responsibility of the Official Service Contractors to clean the catwalks at the completion of each show. It is also required that the Official Service Contractor maintain the catwalks in a clean and safe environment during move-in and move-out. No items may be thrown off the catwalks (i.e. equipment, trash, etc.).

FLOOR PLANS

- Floor Plans for the Exhibit Halls, Lobbies, General Sessions and Meeting Room exhibits must be submitted (30) days before the start of move-in. Plans may be submitted to boothplans@lvcva.com
- Floor Plans for Exhibit Halls and Lobbies must be submitted as separate documents.
- When it becomes necessary to revise an approved floor plan, please highlight all changes on the plan and re-submit.

FIRE PREVENTION RULES AND REGULATIONS

- All operators on LVCC/Cashman Center property must have successfully completed an approved course of instruction regarding the safe operation of forklifts, scissor lifts and boom lifts. The Employers Insurance Company of Nevada, the Department of Industrial Relations (Safety Consultation and Training Section) or the National Safety Council can provide assistance to an employer for the development of this certification program. The certification of successful completion of this course must be in the driver's possession while operating a forklift on LVCVA property. LVCVA Security officers will make random checks for proof of certification and failure to provide such proof will result in the operator being prohibited from further operation of a forklift on the property and possible trespass from property.
- **LVCC Only:**
 - On the North Road, vehicular traffic is from east to west, with only emergency access from Paradise Road eastbound.
 - Pedestrian crosswalks have been striped between Westgate and the Skywalk entrance. Crosswalks must remain clear at all times. Trucks, trailers, forklifts, crates and equipment may not be parked or left in the striped areas
 - A 20-foot clear area around fire hydrants must be maintained along North Road and throughout the Las Vegas Convention Center.

TRAILER & EMPTY STORAGE

- Official Service Contractor trailer storage is only permitted in the parking lots with the prior approval of the Senior Director of Convention Services or the Senior Manager of Convention Services.
- **LVCC Only:**
 - No parking, storage, or staging of any type, vehicle or equipment, is authorized under the meeting room overpass next to Desert Inn Road.
 - The Centerplate loading dock area south of freight door #3 must be clear of any storage and staging.
 - A red line has been painted along the south side of Orange 1 Lot parallel to Desert Inn Road. The purpose of this area is to protect traffic on Desert Inn Road from falling objects. Trucks, trailers, forklifts, crates and equipment may not be parked or left south of these red lined areas. All vehicles, including forklifts and high lifts, must also remain clear of any red painted curb areas.
 - All empty crates must be kept a minimum of 40' from the building in their designated areas with the exception of the north halls, which must be 20' from the building on the north road side only.
 - Empty crates may be staged on the North Road in their designated areas, and stacked no higher than 16'. Storage and equipment is not permitted in the striped areas of the North Halls.
- Crates may be stored on the upper level ramp outside Halls S3 and S4 in their designated areas. With Convention Services Manager approval, crates may be stored at a maximum height of 16' under the South Hall ramp.
- On the North Road, vehicular traffic is from east to west, with only emergency access from Paradise Road eastbound.
 - Pedestrian crosswalks have been striped between Westgate and the Skywalk entrance. Crosswalks must remain clear at all times. Trucks, trailers, forklifts, crates and equipment may not be parked or left in the striped areas.
- **Cashman Only:**
 - Empty crates may be placed outside of Hall A east side against the stadium fencing.
 - Trailer storage is allowed in Parking Lot D (SE corner) with 24-hour security coverage

UTILITIES

- LVCC/Cashman Center fire hydrants may not be used to fill water trucks.
- The LVCVA landscape irrigation system may contain liquid fertilizer and connecting to it in any way for any purpose is prohibited.
- Please observe the following policies with regard to electrical/lighting service:
 - For safety and conservation reasons, the LVCVA will now enforce the following requirements of our existing 24-hour show power policy:
 - All exhibit power shall be shut off no later than one (1) hour after trade shows, conventions, or event closing and will be turned on prior to three (3) hours before opening. Electrical power usage and timing for registration and service desk areas will be determined by show management, the Official Service Contractor's electrical contractor, and the Convention Services Manager.
 - In cases where exhibits require 24-hour power, that power source must be limited to the size outlet ordered by the exhibitor for 24-hour power.
 - A copy of the list of exhibitors requiring 24-hour power, with outlets listed, must be provided to the Convention Services Manager prior to each convention or trade show. In the event it is determined by the LVCVA Director of Engineering that there is an excessive amount of 24-hour power in use, the department may require the Official Service Contractor to provide on-site electrical labor for all hours, including move-in and move-out that the trade show, convention, or event is not in operation.
 - Do not trip breakers or turn off any lights in lobbies or common areas. If the client requests this, advise the LVCVA electrical department and they will provide the necessary service.
 - Facility light bulbs should not be removed.
 - Advise the LVCVA electrical department before you turn out any lights over booths in the exhibit halls.
 - Do not use the door tracks in meeting rooms to hang track lights.
 - Flat cables run underneath carpet in the halls, must be identified with yellow caution tape.

- Do not hang show lights (i.e. for exhibit booths, general session) from the catwalks without permission from LVCVA Director of Engineering/Director of Facilities Operations and the Convention Services Manager.
 - All electrical panels shall be re-secured after use. All dead front covers, panel board covers, KO seals, and hardware securing covers to the enclosures shall be re-installed to maintain the integrity of electrical equipment. All show power cables coming from electrical panel interiors, shall be removed after each show and panels shall be re-secured accordingly.
 - All light fixtures throughout the exhibit halls that were unplugged before or during a show shall be plugged back into their designated receptacles after the show has ended. Any calls received in engineering for a "light out" due to a fixture left unplugged from the previous show shall be forwarded back to the Official Service Contractor for immediate service at their own expense.
 - Whenever electrical circuits are intentionally turned off for a show, by show electricians, either by turning off circuit breakers or by turning off light switches, these circuits should be identified and marked by the show electricians, so our in-house electricians are aware of the situation. This prevents us from turning on circuits accidentally during a show. Placing red tape with a company name and the date lights were turned off on the circuit breaker or switch is all that is needed.
- Official Service Contractors will replace all drain covers immediately after the show has ended.
 - Work on energized panels >50 volts AC is only to be performed by a qualified electrician. With arc-flash clothing (as per NFPA 70E), insulated tools, rubber gloves, and any other electrical protective equipment as required by OSHA.
 - Whenever possible, when working on electrical circuits they shall be de-energized and lockout/tag out applied. Lockout/Tag out must be coordinated with the LVCVA through the CSM. Locks and tags shall be supplied by the contractor and shall be removed immediately upon completion of work.

ADDITIONAL PLANNING NOTES

- Nothing may be hung from or attached to the roof system of LVCC/Cashman Center without approval from the LVCVA Director of Engineering/Cashman Director of Facility Operations. LVCC/Cashman has a suspended load limits procedure, and it is the contractor's responsibility to ensure that the weight limits are not exceeded. (Refer to "Rigging" in this section for further information.)
- Do not attempt to walk on the beams in the lobbies and Grand Concourse. These beams are hollow and will not support the weight of a person.
- Carpeting can be placed on top of building carpet in the meeting rooms and lobby areas with permission from the Convention Services Manager. Visqueen must be laid between the building carpet and the carpet being installed. Use only non-residue tape. All carpet must be pre-cut, cutting is not allowed over building carpet.
 - When carpeting stairs, please contact your Convention Services Manager for approval.
- Freight door #1 will be limited when there is other show activity in the building. Contact the Convention Services Manager to coordinate use of freight door #1.
- Due to security concerns, all catwalk and roof access locations must remain secure. Taping or blocking open an access will be grounds for trespass from property.
- The use of low tack, self-adhesive visqueen is not permitted on lobby or hallway carpeting. Low residue, cloth gaffer tape is recommended
- Any trailer being used as an onsite office, workspace or storage unit must have prior approval from the Convention Services Manager. It must also have a 2'x2' sign readily visible to identify its owner.
- All charging equipment must be code compliant and listed for intended use.

CONTRACTOR AND VENDOR REQUIREMENTS

Any show-appointed and/or exhibitor-appointed company providing a service during conventions, trade shows and events on the property of the Las Vegas Convention Center or Cashman Center must comply with the following requirements prior to commencement of work at either facility. [The Contractor and Vendor Permit](#) application must be completed annually.

- **ANNUAL CONTRACTOR FEE** \$250.00

- **CERTIFICATE OF INSURANCE**
 - Workers' Compensation Coverage in the State of Nevada
 - **If the home state of the contractor does not have a reciprocal agreement with the State of Nevada, contact Employers Insurance Company of Nevada (EICN) to obtain proper coverage. Phone (702) 837-3000 or www.employers.com**
 - General Liability in the amount of one million dollars (\$1,000,000) combined single limit bodily injury and broad form property damage coverage, including broad form contractual liability, naming the Las Vegas Convention and Visitors Authority as additionally insured.

- **LEGAL COMPLIANCE – SIGNATURE REQUIRED BELOW**
 - For and in consideration of the Permit, each contractor agrees to indemnify, defend and hold the LVCVA harmless for damages, claims or expenses incurred by the LVCVA that are attributable to the contractor or its actions or inactions at the LVCC/Cashman Center. Such damages, claims or expenses include, but are not limited to, those related to (1) the handling of hazardous materials; (2) negligence or intentional conduct; (3) violation of any law or regulation; and (4) additional security resulting from labor strikes and the like. Where appropriate, expenses will be charged to the responsible contractor on a pro rata basis.

- **BUSINESS LICENSE**

ALL CONTRACTORS MUST OBTAIN A BUSINESS LICENSE WHEN WORKING AT EITHER THE LAS VEGAS CONVENTION CENTER OR CASHMAN CENTER. Please click <http://www.clarkcountynv.gov/business-license/Pages/BusinessLicenseServiceSpotlight.aspx> or contact the following entities below for further information:

Clark County Department of Business License
500 Grand Central Parkway, Third Floor
Las Vegas, NV 89155
(702) 455-0174
clarkcountynv.gov

City of LV Dept. of Business Licensing
333 N Rancho Dr.
Las Vegas, NV 89106
(702) 229-6281
lasvegasnevada.gov

**All documentation must be received before work may commence on the property of the Las Vegas Convention Center or Cashman Center. **

FLORAL/PLANT CONTRACTORS RULES

- To prevent damage to the building, floral and plant operations may not be staged on any carpeted area in the LVCC/Cashman Center without prior approval from the Convention Services Manager. If approval is granted, visqueen must be placed over all carpeted areas.
- If you have made arrangements for a floral contractor and are unable to provide them with a staging area on the exhibit floor, please contact your Convention Services Manager for detailed procedures.

HAND CARRY

- Exhibitors may hand carry their merchandise from a privately owned vehicle. Acceptable vehicles include passenger automobile, minivan, sport utility vehicle, pick-up truck and full-size van.
- Trailers of any kind, box trucks or vehicles larger than a full-size van or pick-up truck will be permitted in areas predetermined by the Las Vegas Convention Center.
- Parking on a red curb or in traffic lanes is prohibited.

- The use of hand carts & dollies is not permitted.

Four wheel dollies



Two wheel dollies



Four wheel push carts



HOT WORK

RULES AND REGULATIONS FOR INSTALLATION AND DISMANTLE OF BOOTHS ON LVCVA PROPERTY

Hot Work is any activity that creates sparks or uses open flame, including, but not limited to, brazing, soldering, oxygen cutting, arc welding, oxy-fuel gas welding, hot taps and torch applied roofing or flooring, or any cutting of wood or metal that creates sparks.

Any form of Hot Work, whether inside the facility or outside the facility, used for the installation of a show or the dismantling of a show, MUST be pre-approved by the Fire Prevention office of the LVCVA. The Fire Prevention office will issue a Hot Work Permit to the person / persons performing the Hot Work. The permit will be valid for one shift or until the completion of the project, whichever is first. The permit is job specific and may not be transferred to another task or carried over to the next shift

The following will be required of the person/persons performing the work:

- Before beginning work, the work area shall be visually observed by the person performing the hot work and the person issuing the hot work permit. The permit tag checklist shall be completed jointly then signed by the worker and the person issuing the hot work permit. The hot work site will be inspected for:
 - i. Removal of flammable materials from the area;
 - ii. Clear of combustible materials and/or ensure combustible materials are protected;
 - iii. Ensure floor and wall openings are protected;
 - iv. Ensure floors and surfaces are swept clean of dust and debris;
 - v. Walls and partitions are non-combustible or protected;
 - vi. Determine the number and locations of fire watch and fire extinguishers
- The Hot Work Permit tag shall be posted in the area of the work activity in a plainly visible location for the duration of the work.
- No hot work activities will be allowed when the fire protection system covering that area is out of service.
- No welding, cutting, grinding or heating activities shall be performed where the applications of flammable paints or other compounds, or heavy dust concentrations create a hazard.
- All hot work shall require at least two persons: one conducting the hot work activity, and one to function as a fire watch. The entity conducting the hot work activity shall provide the fire watch.

- The fire watch shall continue for a minimum of 30 minutes (up to a maximum of 3 hours) after the conclusion of hot work activities. The duration of fire watch shall be determined by the Fire Prevention Office based on the hazards associated with the hot work activity.
- Hot work conducted in areas not observable by a single person (i.e. multiple levels where sparks and slag can fall to a lower unobserved level) shall have additional personnel assigned to fire watch to ensure that all exposed areas are monitored.
- Individuals designated to fire watch duty shall have fire extinguishers of at least 10 lbs. ABC dry chemical readily available. The entity conducting the hot work activity shall provide the extinguisher.
- Fire watch persons will have recent training in fire safety, fire extinguisher use, and emergency reporting.
- Persons assigned to fire watch duty shall understand emergency reporting procedures and have means to contact the Control Center.
- At the end of the shift or completion of the work, the area shall be inspected by worker(s) and/or fire watch and found to be free from sparks, fire, smoke, etc.
- When the work has been completed (including the required fire watch period), the released Hot Work Permit shall be signed off by the person responsible and delivered to the Fire Prevention Office.

Unless special conditions exist, no permit is required when performing hot work in a welding shop or other area specifically designed for these functions.

LVCC Only: This policy does not replace the need for an exhibitor to retain a Hot Work Permit from the Clark County Fire Department when Hot Work is performed during the actual show or event.

Please contact the Fire Prevention Office for additional information.

RIGGING

- The Lessee/Show Manager will be responsible for adhering to the following rules and regulations as it pertains to rigging as indicated below.
- Inform your Convention Service Manager of the person that will be responsible for all rigging 60 days prior to the start of any rigging work. This person will be responsible for all rigging installations and removal.
- Rigging plans must be submitted to riggingandsprinklers@lvcca.com no less than 14 days prior to the first move in day.
- Ensure that the overall rigging plan is done in accordance with the suspended load limits procedure as prepared by LVCVA's structural engineering consultant. The weight load limits provided are not to be exceeded.
- Only trained and qualified riggers may be used.
- All hoist motors and rigging apparatus must be inspected before they are installed. At a minimum, all hoist motors must be visibly inspected yearly and weight tested every two years by a certified inspector. Certification papers for hoist motors must be provided within one hour of a request.
- Carpet and/or burlap material and any other material used to protect a beam against steel cables, chains for rigging point, shall be removed after the show.
- All rigging structures hung more than three feet above the floor must have safety devices as a backup. The backup device must be capable of sustaining the load for which it is providing backup.
- The LVCVA Engineering Management team must be notified in advance of any weight loads that will reach the maximum capacity of rig points in any particular area or if there is any unbalanced weight loads or structures, i.e., vehicles, boats, etc. This rigging shall have an implemented, supplemental, support system that connects into the facility overhead rigging points. These systems shall be designed, reviewed and stamped by a licensed engineer. A copy of the stamped design must be sent no less than 14 days prior to installation to riggingandsprinklers@lvcca.com
- Any weight load exceeding the building load limit will be removed at the Lessee/Show Manager's expense immediately.

- The catwalks have a weight restriction of 25 pounds per square foot, calculations must be made for transformers, dimmer apparatus, electrical cables and storage boxes to ensure that this weight is not exceeded.
- Rigging apparatus, supports or devices used for hanging truss made of non-metal material such as span set straps or nylon rope shall not be used near house light fixtures. The minimum distance shall be three (3) feet. this also applies to safety or backup supports, cables or straps. Only chain or aircraft cable may be used.
- No rigging apparatus shall be hung in such a way that it deflects the air flow or affects the temperature of the cooling and heating systems in the exhibit halls, meeting rooms or hallways of the Las Vegas Convention Center.
- Ground/floor based rigging/truss is not permitted without each leg of the structure terminating at floor level via footing or base plate. Rigging/truss structures that require jointed legs will only be permitted with jointed legs that consist of two legs with joints and two legs that make up a flat mating surface that bolt together.
- Ground/floor based rigging/truss/drape that exceeds 16 feet in height must have an overhead support system that connects into the facility rig points unless there is an engineered stamp drawing indicating that this is not necessary.
- **LVCC Only:** The following items are specific to rigging in the South Halls:
 - Using cable trays as support devices for rigging, signs and electrical cables shall not be permitted.
 - The first floor steel beams cannot be used for any rigging or hanging purposes. This includes signs and/or cable guides.
 - Cable trays cannot be used for temporary staging or storage of any material other than which it was designed (telephone cable, fiber cable and television cable).

RIGGING SUBMITTAL PROCEDURE

- Rigging drawings shall be submitted electronically in either pdf or dwg format no later than 14 days prior to the first day of installation.
- All weight loads requiring professional evaluation shall be sent to riggingandsprinklers@lvcva.com with weight loads clearly marked on the plan. A copy of the evaluation will be sent back to the submitter and the Convention Services Manager prior to rigging install.
- The booth layout, and associated rigging loads, shall be overlain onto the full rigging plans, and submitted as one complete file.
- If changes are made after submittal to LVCVA, those changes shall be clouded and clearly stated and the file resubmitted.
- The point loads shall be shown on the booth layout plan at the point of hoist. The distributed loads shall also be shown on each purlin/beam/truss that will be used as a point of attachment. Use leaders/arrows to indicate method of distribution to purlin/beam/truss.
- All diagrams on the current Rigging Plans shall be followed.
- **LVCC Only:** In the lower level of South Hall, lugs may be added and shall be installed per the detail (Lug Detail) shown on the Rigging Drawings. Prior to installation, LVCVA shall be notified with a plan, indicating location of new lug. Welding shall be done by a welder certified for the appropriate welds and a Hot Works Permit shall be obtained by the LVCVA Fire Prevention Department prior to the welding occurring. Special Inspection by a qualified welding inspector shall also be provided. Welder Certification and Special Inspection Report shall be submitted to LVCVA each time.

FEDERAL AND STATE GUIDELINES

ADA – AMERICANS WITH DISABILITIES ACT

The Americans with Disabilities Act is a civil rights act providing equal opportunity in the areas of employment, state and local government services, public accommodations, transportation and telecommunications.

- The Lessee, its sub lessees and contractors, must comply with the ADA as indicated in the lease agreement. All permanent aspects of the facility are the responsibility of the LVCVA. Access to any given show and the services they are providing are the responsibility of the Lessee.
- “Access Las Vegas” brochures and “ADA Accessibility Maps” are available. Contact your Convention Services Manager for copies.

SERVICE ANIMALS

- Under ADA’s regulations, the definition of “service animal” is limited to a dog that is individually trained to do work or perform tasks for an individual with a disability. The task(s) performed by the dog must be directly related to the person’s disability.
- Under the ADA, “comfort,” “therapy,” or “emotional support” animals do not meet the definition of a service animal.

NEVADA DEPARTMENT OF TAXATION

- The Nevada Administrative Code (NAC) 372.180 states that the promoter or organizer of an event allowing any retail sales on the show floor has the responsibility to collect and remit the taxes for their respective event.
- If Show Management or exhibitors are tax-exempt, the State of Nevada requires a copy of the following on file with the LVCVA
 - Nevada tax-exempt sales tax permit providing the evidence of non-taxability
 - U.S. Government tax-exempt sales tax permit
- Please contact the Nevada Department of Taxation at (702) 486-2300 for further details.

NON-SMOKING POLICY

- In accordance with the Nevada Clean Indoor Air Act, LVCC/Cashman Center are non-smoking facilities.
- The uses of electronic cigarettes, electronic vaping devices, personal vaporizers or electronic nicotine delivery systems are not permitted within the facility.

RAFFLES

- For raffle/gaming inquiries, please contact the Nevada State Gaming Control Board at (702) 486-2020.

LEASING AND INSURANCE

INSURANCE AND INDEMNITY

- As the Lessee, you must provide the LVCVA with a copy of the show's insurance certificate for liability and workers compensation insurance thirty (30) days prior to the first move-in date or as otherwise set forth in the Lease Agreement.
- The certificate must list the total days leased in the facility and include all indicated coverage set forth in the Lease Agreement, including commercial general liability and automobile liability.
- All issuing insurance companies must have authorization to do business in the State of Nevada. This certificate of insurance must state that the **Las Vegas Convention and Visitors Authority** is an additional insured.
- Automobile liability coverage referenced in the Lease Agreement is required to remove the exception from coverage for vehicle incidents set forth in most Commercial General Liability policies.
- Contact your Convention Services Manager for assistance.
- See sample [Certificate of Insurance](#)

LEASE

- You have thirty (30) days from the day you receive the lease to sign and return it. You must advise us if you cannot meet this deadline.
- Meeting rooms used for exhibits are charged at double the current rate. Meeting rooms subleased for meetings will be charged the minimum daily rate, whichever is greater. Final charges for meeting rooms will be determined at the close of the show.
- The LVCVA has retained certain exclusives. These include but are not limited to telecommunications, **and** food service. (**LVCC only – includes exclusive business center services.**) Contact your Convention Services Manager if you have any questions about LVCVA exclusives.
- Standard meeting room equipment such as tables and chairs will be provided at no charge. Special equipment such as bleachers will be invoiced at the current rate.
- **LVCC/Cashman Center** will clean public areas, meeting rooms (when used for meetings only) and rest rooms during your leased period. We will not clean parking lots that are used for exhibits. For security reasons we do not clean show offices and we do not clean meeting rooms when used for storage or workrooms.
- You must furnish the LVCVA in writing a list of companies (i.e. I&D, florists, EACs, etc.) who are providing a service to you or your exhibitors. You are responsible to make sure they are properly licensed and insured and authorized to work in the LVCC or Cashman.
- All lobbies, concourses, skywalk and pedestrian bridge are included as leased space but are considered to be public space at all times. Commercial exhibits are not permitted in such public spaces.
- **LVCC only** - Tents, pavilions or exhibits are prohibited in any rainwater swale area.
- Payments of fees, advance deposits or invoices may be accepted by credit card without limitation if payment is received on or before the thirtieth (30) calendar day after the invoice date. Payment methods accepted include cash, check, money order, ACH, wire, and all major credit and debit cards; however, the LVCVA reserves the right to restrict credit card transactions on past due accounts.

LICENSES –CASHMAN ONLY LEASE

- Lessee shall obtain all permits or licenses required by laws, ordinances, rules and regulations from the City of Las Vegas. For further information, please contact:

City of Las Vegas

Department of Planning

Business License Division

Phone: (702) 229-6954 Fax (702) 382-6642

Please be aware that our office is CLOSED on Fridays

lasvegasnevada.gov

City of Las Vegas Business Licensing

PARKING

PARKING

❖ GENERAL INFORMATION

- The current parking fee is \$10.00 at LVCC and \$5.00 at Cashman Center (we accept cash or credit cards) per space with in and out privileges. Anyone leaving the **LVCC/Cashman Center** and planning to return the same day can show their paid parking receipt for reentry. Reentry is subject to availability.
- Vehicles must be parked in designate parking spaces only.
- Vehicles taking up more than one standard parking space will be charged accordingly upon entry when paid parking is in effect.
- Overnight parking is prohibited on **LVCC/Cashman Center** property. Vehicles left on the property overnight will be towed at the owner's expense.
- **LVCC Only:** When not used as part of an outdoor exhibit, the only parking lots where privately owned, enclosed vehicles (i.e., box vans, RVs, enclosed trailers, etc.) are permitted to park is the Gold, Bronze, Diamond and Platinum Lots, when available.
- Parking lot capacities are available upon request.
- Individuals with special parking situations or concerns should inquire at the Traffic Office for assistance at (702) 892-7400.

❖ ADDITIONAL PLANNING NOTES

- All parking attendants and traffic control personnel will be provided by LVCVA for standard traffic operations.
- Official Service Contractor trailer storage, in designated lots, must be approved in advance. Contact your Convention Services Manager.
- Parking is prohibited at all loading docks, dumpsters, compactors, entrances to buildings, along drives, crosswalks, hashed-out areas, fire hydrants, building perimeter red-lined areas, spaces posted with signs, red curbs, yellow curbs, or anywhere the vehicle constitutes a safety or other hazard. All drives are fire lanes unless marked for parking. A vehicle parked on a sidewalk is subject to removal. Vehicles must be parked in a marked parking space at all times.
- **LVCC Only:** -- No shuttle bus/truck staging with long term engine idling (Clark County, NV Board of Health, APC Reg: Sec 45.1) is permitted along the South Drive or North Road at any point.
- Paid parking dates are determined by building activity. If other shows are in the building at the same time, paid parking could be in effect during your move-in/move-out period. Check with your Convention Services Manager for paid parking dates.
- When lot usage is for parking, a minimum number of ADA accessible parking spaces will remain and be determined by LVCVA management with traffic control personnel provided by the LVCVA.
- When lots are leased by Show Management for parking, lots may not be resold without prior approval from the LVCVA Senior Director of Convention Services and the charge cannot exceed the LVCVA standard fee per vehicle.
- Your Convention Services Manager will provide a limited number of complimentary show staff parking passes.

PARKING LOTS

- When lots are used for a special event or exhibits, see Outdoor Exhibit Guidelines.
- If a portion of a lot is leased for ancillary or exhibit space, entrances/exits cannot be blocked or restricted. **LVCC Only:** -- When parking lots are leased for exhibits and special events, a floor plan must be submitted for approval by the Clark County Fire Department, and when applicable, by the Clark County Building Division (See Temporary Exhibit Structures in the Building Guidelines section.) **Cashman Center:** --When parking lots are leased for exhibits or special event, a floor plan must be submitted for approval by the City of Las Vegas Special Events Department.
- Show Management is responsible for providing contract security.
- **LVCC Only:** -- Staking plans must be submitted to your CSM prior to any staking/drilling in the parking lots
- **Cashman Center only:** If music or broadcasting the client must lay out their activity so speakers are not facing residential areas to the East and South. Reasonable sound levels must be adhered to.
- Contract cleaners, selected by Show Management, are responsible for cleaning the lots.

- When lots are used for driving demonstrations, racing events or vehicle performance demonstrations, contact your Convention Services Manager for guidelines.
 - Parking lots must be returned in the same condition as the lots were originally leased.
- ❖ **PLATINUM LOT RESTRICTION– LVCC Only**
- The South and West perimeter of the Platinum Lot must remain clear 28' from fence line. Only private vehicles will be permitted in that area.

PUBLIC EVENTS

GUN SHOW POLICIES AND PROCEDURES

- The Lessee must obtain approval from the Las Vegas Metropolitan Police Department (Metro) and have Metro on property during all gun shows. Contact LVMPD's Events Planning Section, 702-828-3442.
- Metro will be posted at a table near the entrance and any firearm brought into the show must be inspected by Metro. The inspection will consist of checking the serial number to confirm the firearm has not been reported stolen or used in a crime and ensuring the firearm is unloaded.
- Concealed firearms are prohibited on property as provided in N.R.S.202.3673.
- Metro will zip tie all firearms that are cleared and taken into the show. The show manager is responsible for supplying the zip ties.
- Vendors/Attendees must remove magazines or ammo clips from the weapon prior to entering the building. This applies to move-in/move-out activities as well as show days.
- Vendors/Attendees will not have loaded weapons inside the building or on the show floor unless authorized by the Executive Director of Customer Safety or his designee.
- Firearms (handguns, rifles, shotguns, etc.) may be legally bought and sold at gun shows in Clark County. In order to complete the sale, the Lessee must make arrangements to have a local licensed firearms dealer on property to handle transfers and conduct background checks. All firearm sales will go through this dealer.
- All sales of firearms or ammunitions must be conducted on the show floor.
- Show contract security is responsible for checking that all firearms leaving the building have a receipt and the serial number on the receipt matches the firearm. The show security desk should be located near the Metro desk so if a discrepancy is discovered Metro can handle the situation.
- For safety/fire reasons black powder is strictly prohibited inside the facility.
- Please complete the "[Application for Combustible for Explosive Products to be Sold, Displayed or Kept within Exhibits](#)" form prior to show for approval by the LVCC Fire Prevention Office. Email to boothplans@lvccva.com.

SAFETY

FIRE AND SAFETY EXHIBIT GUIDELINES

- All means of entrance and exit must be clear and free from obstruction at all times.
- Each hard wall booth must be a minimum of nine (9) inches from the booth line for access to electrical.
- No storage of any kind is allowed behind booths or near electrical service. A one-day supply of product is permitted within but cannot be stored behind the booth.
- All fire hose racks, fire extinguishers and emergency exits must be visible and accessible at all times. Should this equipment be within a booth or exhibit due to the layout of floor space, additional signage indicating fire equipment location(s) (extinguisher, hoses, etc.) will be necessary, along with accessibility being maintained at all times.
- Exhibit booth construction shall meet the requirements of 2003 NFPA 101, 13.7.4.3.4. The upper deck of multi-level exhibits greater than 300 square feet (28 sq. m) will need at least two (2) remote means of egress. (2003 NFPA 101, 13.7.4.3.3). The upper deck, if occupied, must be rated at 100 psf live load. All materials used in exhibit construction, decoration, or as a temporary cover must be certified as flame retardant or a sample must be available for testing. Materials which cannot be treated to meet the requirements may not be used.

- Construction and demolition of multi-level booths and exhibits requires compliance with OSHA fall protection regulations (20 CFR 1910 Subpart D and 1910.140) for general industry requirements.
- Halogen and quartz lamp use must be reviewed with the Convention Services Manager and the Fire Prevention office. See Halogen Lamp Restriction in this section.
- Vehicles on display (per 2003 NFPA 101, 13.7.4.4):
 - Fuel tank openings shall be locked or sealed in an approved manner to prevent escape of vapors; fuel tanks shall not contain in excess of one-quarter their capacity or contain in excess of 19L (five gal.) of fuel, whichever is less. (NFPA 101, 13.7.4.4.1)
 - At least one battery cable shall be removed from the batteries used to start the vehicle engine, and the disconnected battery cable shall then be taped. (NFPA 101, 13.7.4.4.2) Batteries used to power auxiliary equipment shall be permitted to be kept in service.
 - Batteries must be disconnected. Auxiliary batteries not connected to engine starting system may be left connected.
 - Electric and hybrid vehicles shall have their operating batteries disconnected whenever possible.
 - External chargers or batteries are recommended for demonstration purposes.
 - No battery charging is permitted inside the building.
 - Combustible/flammable materials must not be stored beneath display vehicles.
 - Fueling or de-fueling of vehicles is prohibited (NFPA 101, 13.7.4.4.4)
 - Vehicles shall not be moved during exhibit hours.
 - 36" of clear access or aisles must be maintained around the vehicle.
 - Vehicles must be a minimum of 20 feet from exit of door or exit pathway.
 - No leaks underneath vehicles.
- Model/modular home displays in trade shows must be reviewed with the Convention Services Manager. In addition, a floor plan of the model/modular home must be submitted to the LVCVA Fire Prevention Office.
- Vehicles in the building for loading or unloading must not be left with engine idling.
- Except for equipment that uses LPG or natural gas as fuel, compressed gas cylinders, including LPG, and all flammable or combustible liquids are prohibited inside the building. Any other exceptions require prior approval by the Convention Services Manager and the Fire Prevention Office. Overnight storage of LPG, natural gas as fuel or compressed gas cylinders is prohibited in the building. The following regulations apply to the use of LPG (propane) inside and outside the Las Vegas Convention Center. Any use of LPG (propane) on LVCVA property must be approved prior to arrival by the LVCVA Fire Prevention Office. (NFPA 101, 13.7.4.5 Prohibited Materials)
 - When approved, LPG (propane) containers having a maximum water capacity of 12lb [nominal 5lb LP-Gas capacity] may be permitted temporarily inside the convention facility for public exhibitions or demonstrations. If more than one such container is located in an area, the containers shall be separated by at least 20ft.
 - Any exception to the first two requirements above must be submitted for review and approval by the LVCVA Fire Prevention Office and the Convention Services Manager.
 - All LPG (propane) containers must be separated and inaccessible to the public. Cooking and food warming devices (see FOOD PREPARATION WITHIN EXHIBITS in this section) in exhibit booths shall be isolated from the public by not less than 48 inches (1220mm) or by a barrier between the devices and the public. (2003 NFPA 101, 13.7.4.5.1)
 - The after-hours, overnight storage of any LPG (propane) container inside the convention facility is strictly prohibited. Containers must be removed at the end of each day and can be delivered back to the show floor upon the arrival of exhibit staff in the morning.
 - Propane cylinders awaiting use should be stored in a secured propane storage cage that meets the requirements of OSHA. Storage cages must be secured in a location selected by LVCVA staff outside of the building.
 - No dispensing from or refilling of LPG (propane) containers will be permitted inside of the convention facility.
 - Use of LPG (propane) outdoors must be approved by the LVCVA Fire Prevention Office and the Convention Services Manager prior to arrival on LVCVA property. No outside LPG (propane) will be permitted in any areas where building exits discharge or Fire Department access is required.

- Areas enclosed by solid walls and ceilings must be provided with approved smoke detectors which are audible outside the area of the booth. A fire watch may be required. (See Multi-Deck and/or Covered Exhibits for more information.)
- The travel distance within the exhibit booth or exhibit enclosure to an exit access aisle shall not exceed 50ft. (2003 NFPA 101, 13.7.4.3.2)
- Exhibitors who plan to demonstrate fuel-burning appliances in the LVCC/Cashman Center must have approval from the Convention Services Manager 60 days prior to the event.
- Fireplaces must be listed as vent less or self-venting for indoor use in order to obtain approval for burning inside the facility.
 - Vented fireplaces cannot be burned since venting directly outdoors is not possible.
 - Only enclosed fireplaces will be approved for burning, meaning the fireplace must be enclosed with a glass front or a protective heat/contact barrier must be installed to prevent combustible exposure or attendee contact.
 - Screen front fireplaces will not be approved for burning.
 - Exhibit design directly around the fireplace and installation of the fireplace must meet the requirement/code for permanent fireplace installation. Distances from exposure to combustibles must meet the requirements for permanent installations.
- Candles may be used for decorative purposes for events with food service (1 candle per table) where the candles are supported by/on substantial non-combustible bases so located as to avoid danger of ignition of combustible materials. Candle flames shall be protected and enclosed so that if the candle were to tip over, there would be no risk of fire. The Fire Prevention Office has final approval to determine if a candle meets the above criteria. Candles may not be left unattended while lit. Intended use of candles for decorative purposes must be listed on the "Food and Beverage Sampling/On-Site Preparation Approval Form" and submitted to foodprepandsample@lvcva.com.

FLOOR PLANS

Floor plans are required for all areas including exhibit halls, lobbies, meeting rooms, outdoor plazas and parking lots.

❖ FLOOR PLAN GUIDELINES

- Floor plans must be drawn to scale and include all structures, obstructions and booths.
- Lobby floor plans must be on a separate scaled drawing showing all booths, displays, kiosks, signs, vehicles, etc. Please note that all public areas may not be subleased space and all use of this space must be approved by the LVCVA.
- Floor plans should include the following scale for equipment for meetings and general sessions
 - Chair – 20" x 20"
 - Row Spacing from back of chair to front of chair – 18"
 - Staging – Any 4' x 8' configuration within the limits of our inventory.
 - Heights – 16", 24", 32" and 36" to 54" in 2" increments.
 - Tables – 8' x 18", 8' x 30", 72" round – all 30" high
- **LVCC Only:** To most effectively use the lobby areas and the reconfiguration of the exhibit halls, we strongly suggest show managers consider using the telescoping overhead doors as the "Main Entrance." The banks of smaller walk-through doors are intended as Exits only and, by code, must not be held open by wedges, props, ties or any holders other than the magnetic self-releasing locks.

❖ SUBMITTAL INSTRUCTIONS

- All floor plans submitted to the LVCVA Fire Prevention Office for approval come from either the Lessee or the Lessee's Official Service Contractor
- The approval process for all floor plans is a two-step process. First, the LVCVA Fire Prevention Office must approve it. It is then forwarded to the Convention Services Manager. A plan must be "signed off" by both departments before it is considered an "Approved" plan.
- Once the Lessee has approved the floor plan, it should be labeled with a number and date and forwarded. Floor plans should be sent via e-mail (boothplans@lvcva.com) to the LVCVA Fire Prevention Office for approval. A copy of the approved floor plan will be returned approved or denied. Reasons for denial will be noted on the returned plan.
- When it becomes necessary to resubmit or revise a floor plan, please follow the above procedure. Number and date the revision and include a cover letter detailing the revised parts of the floor plan. Minor changes, such as booth or island sizes, may be faxed (702) 892-2919 or e-mailed

(boothplans@lvcva.com) to the LVCVA Fire Prevention Office for interim approval with a cover letter noting the plan that is changed and with a 1A, 1B, etc. designation. All of the interim changes can be combined in a final floor plan prior to move-in.

- Floor plans must be submitted and approved in advance before space is sold or assigned. This is to ensure that exits, aisles, fire protection equipment, etc. are clear and unobstructed. The Fire Prevention Office and the Convention Services Manager must approve any changes before they may be put into effect.

FOOD PREPARATION WITHIN EXHIBITS

Whenever food is prepared within an exhibit, an Application for Food Preparation or Sampling form must be completed and emailed to conventionservices@lvcva.com. Upon receipt of this form, your Convention Services Manager will approve and/or forward the information to the Las Vegas Convention Center Fire Prevention Office and Centerplate.

EXHIBITION AND DISPLAY COOKING

Temporary exhibition and display cooking is only permitted within the limitations given below.

- All cooking appliances shall be listed or approved by a nationally recognized testing agency, i.e. Underwriters Laboratories, Inc., American Gas Association.
- All cooking equipment is to be operated according to the manufacturers' recommendations and operating instructions. Equipment recommended for outdoor use shall not be used indoors.
- All multiple-well cooking equipment using combustible oils or solids and cooking surfaces, i.e. grills that exceed 288 square inches that produces grease laden vapors must have a fire extinguishing system installed according to NFPA17A and an exhaust duct system complying with the currently adopted Mechanical Code.
- All single-well cooking equipment (deep fat fryers), operations using combustible oils or solids shall meet all of the following criteria:
 - Metal lids sized to cover the horizontal cooking surface are to be provided.
 - The cooking surface is limited to 288 square inches (2 square feet).
 - The equipment shall be placed on a noncombustible or limited combustible surface. Examples include concrete floors and Fire Resistance Treated (FRT) plywood. The noncombustible surface must extend three (3) feet in front of the fryer.
 - The fryer is to be separated from all other equipment by a distance not less than 24 inches.
 - These cooking displays must be separated from all other combustibles by a distance not less than 10 feet.
 - The volume of cooking oil per appliance is not to exceed 3 gallons.
 - The volume of cooking oil per booth is not to exceed 6 gallons.
 - Deep-fat fryers shall be electrically powered and have a shut-off switch.
- Other appliances for exhibition cooking shall also be limited to 288 square inches in area. Examples are induction cook tops, ranges, electric warmer, single burner ranges, multiple burner ranges.
- A minimum of (1) Class-K fire extinguisher shall be located within 30 feet of each deep-fat fryer and each grill or other appliance producing grease laden vapors.
- A minimum of (1) Class 2A-30BC fire extinguisher shall be located within each booth with additional or other display cooking such as baking, sauté, braising, stir fry, convection cooking, warming of food, and all other like applications.
- Solid fuels including charcoal and woods are prohibited within exhibit halls.

FOOD SAMPLING INFORMATION FOR EXHIBITORS

The Southern Nevada Health District enforces regulations for the sampling of food during tradeshows.

Exhibitors who are giving away free, open food or beverage are required to submit an Application for Food Preparation or Sampling form to conventionservices@lvcva.com. Upon receipt of this form, your Convention Services Manager will approve or forward for approval to the Las Vegas convention Center Fire Prevention Office. A member of the Centerplate management team will contact you.

- All items to be given away are limited to sample sizes
 - Non-alcoholic beverages: 3oz
 - Food items: 2 oz
- Any food items not directly manufactured by the exhibitor must be purchased from, and supplied by Centerplate.
- If sampling of open food or beverage is conducted at a booth, both a hot water hand-washing station and a sanitizing station will be required.
- Hand washing and sanitation stations may be purchased through Centerplate, or provided by the exhibitor. If provided by the exhibitor, contact the Southern Nevada Health District or refer to their website for the requirements, southernnevadahealthdistrict.org.
- Hot water for hand washing will be provided by Centerplate. Hot water refill station(s) will be available on the show floor. Check with show management for the location(s).

If you have any questions, contact Centerplate at (702) 943-6779 or email exhibitorcateringlvcc@centerplate.com

HALOGEN LAMP RESTRICTIONS

Use of stem or track mounted halogen light fixtures are not allowed unless they meet the following requirements:

- Must utilize a self-shielded bulb
- Bulb wattage must not exceed the listed wattage permitted by the fixture manufacturer
- Wattage may not exceed 75 watts.

UNAPPROVED HALOGEN BULBS



APPROVED HALOGEN BULBS – 75 watts max



MULTI-LEVEL AND/OR COVERED EXHIBITS

RULES AND REGULATIONS

- It is the responsibility of the Exhibitor Appointed Contractor (EAC) to ensure all rules within this section are followed, with the exception of those rules pertaining to the use of a fire watch. The EAC has the responsibility to work with the client to ensure booth plans, as required by this section, are submitted to the Fire Prevention Office no later than 45 days before the first day of move-in for the event. Plans used for prior shows must be resubmitted for approval each time for the upcoming show.
- Multi-level or covered areas. Definitions:
 - **Multi-level** – Any occupied second story or greater area which is accessible by an approved means of egress.
 - **Covered Area** – Any area that covers the exhibit space and prevents the building fire sprinkler system from discharging water unobstructed to the floor. This will include single story exhibits with ceilings, upper deck exhibits, roof, overhead lighting installations, and any materials hanging or installed overhead that is not recognized as acceptable for use under fire sprinkler systems by fire code.
 - **Means of Egress** – An approved stairway or ramp constructed to the specifications of the code used for access and exiting.
- Multi-level or covered contiguous areas in excess of 1,000 square feet are required to have a fire sprinkler system installed by a Nevada State licensed fire sprinkler contractor under the entire area and every level of a multi-level exhibit **only** when the following conditions apply.
 - The exhibit is used in an event where the duration is 7 calendar days or longer.
 - The exhibit contains display vehicles.
 - The exhibit contains open flame.
 - The exhibit contains hot works.
- Any upper deck area to be occupied must have an approved plan with an engineering stamp.
- Multi-level areas that are greater than 300 square feet or which will occupy more than nine persons shall have at least two remote means of egress.
- Means of egress shall be of an approved type and constructed to the requirement of the code.
 - Spiral stairs are not allowed. Spiral stairways are not an approved means of egress for areas occupied by the public, visitors or clientele.
- Exhibits with multi-levels, covered or roofed areas exceeding 300 square feet in size will require the installation of battery-operated smoke detectors. Any covered area that is also enclosed will require the installation of battery-operated smoke detectors regardless of the size of the area. All smoke detectors will emit an audible alarm that can be heard outside of the area.
- Any single level exhibit over 1000 square feet or exceeding 300 square feet of contiguous covered area (see “covered area” definition above) and all multiple-level exhibits must submit a booth plan to the LVCVA Fire Prevention office for approval prior to the exhibit coming onto the LVCVA property. Plans must be submitted in CAD or PDF format via e-mail to: Boothplans@lvcva.com. Booth plans are required to be submitted for each show, regardless if the booth has been approved for any past show by the LVCVA Fire Prevention Office.

FIRE WATCH

- Under certain circumstances, it may be deemed necessary by the Fire Prevention Office to require a fire watch for an exhibit.
- The requirement to have a fire watch will be handled on a case by case basis.

PERMITS

For assistance with Clark County Building and Fire Prevention permitting contact the Las Vegas Convention Center Fire Prevention Department at (702) 892-7413 or boothplans@lvcva.com

LVCC Only: Permits from Clark County Building and Fire Prevention are required for:

- Temporary outdoor tents and membrane structures over 400 square feet
- Canopies over 700 square feet
- Outdoor temporary structures over 4,500 square feet
- Hot work
- Spray and dipping booths

- Cryogenic fluids
- Compressed gases
- Mobile fueling of vehicles
- Open flames and candles not used for food warming
- Open flame torches
- Flame effects and pyrotechnics
- Carnivals

Clark County Building and Fire Prevention also provides blanket permits for multiple exhibitors applying for the same permit at the same show for: hot works, spray and dipping booths, cryogenic fluids and compressed gases. Blanket permits must be submitted to Clark County Building and Fire Prevention office by show management.

PYROTECHNICS AND SPECIAL EFFECTS

Pyrotechnics within the general exhibit space by exhibiting companies is strictly prohibited by the Clark County Fire Department, City of Las Vegas Fire and Rescue, the LVCC/Cashman Center.

- Pyrotechnics for special events (show opening, ribbon cutting, etc.) presented by Show Management may be permitted with the approval of the LVCVA and the Clark County Fire Department. Any pyrotechnic activity must comply with NFPA 1126 (*Standard for the Use of Pyrotechnics before a Proximate Audience*) and be approved and permitted by the Clark County Fire Department.
- Show Management is responsible for providing the appropriate Clark County Fire Department with the written plan of operations within 60 days of the scheduled event date. Please contact the Fire Inspector directly via mail or telephone:

**Clark County Building Department
Fire Prevention Bureau
4701 W Russell Rd
Las Vegas, NV 89118
Telephone (702) 455-7316
Fax (702) 455-7347**

**City of Las Vegas Fire Department
500 N. Casino Center Boulevard
Las Vegas, NV 89101
Telephone (702) 383-2888
Fax (702) 384-1667**

- The plan of operations shall provide the following:
 - Name of the person, group, or organization sponsoring the production
 - Date and time of day of the production
 - Exact location of the production.
 - Name of the person actually in charge of firing the pyrotechnics (i.e. the pyrotechnic operator).
 - Number, names and ages of all assistants who are to be present.
 - Qualifications of the pyrotechnic operator.
 - Pyrotechnic experience of the operator.
 - Confirmation of any applicable state and federal licenses held by the operator or assistant(s).
 - Evidence of the permittee's insurance carrier or financial responsibility.
 - Number and types of pyrotechnic devices and materials to be used, the operator's experience with those devices and effects, and a definition of the general responsibilities of assistant(s).
 - Diagram of the grounds or facilities where the production is to be held. This diagram shall show the point at which the pyrotechnic devices are to be fired, the fallout radius for each pyrotechnic device used in the performance, and the lines behind which the audience shall be restrained.
 - Point of on-site assembly of pyrotechnic devices.
 - Manner and place of storage of the pyrotechnic materials and devices.
 - Safety data sheet (SDS) for the pyrotechnic material(s) to be used.
 - Certification that the set, scenery, and rigging materials are inherently flame-retardant or have been treated to achieve flame retardancy.
- When you receive a permit for your plan from the appropriate Clark County Fire Department, please forward a copy of the plan and permit to your Convention Services Manager and the LVCVA Fire Prevention Office within 30 days of the scheduled event. After a permit has been granted, the permittee shall keep the plan available at the site for Fire Prevention inspectors or other designated agents of the authority having jurisdiction.
- Portable Fire-Fighting Equipment: Two or more fire extinguishers of the proper classification and size as approved by the authority having jurisdiction shall be readily accessible while the pyrotechnics are being loaded, prepared for firing, or fired. In all cases, at least two pressurized water or pump extinguishers shall be available. (*NFPA 1126*)
- Personnel who have a working knowledge of the use of the applicable fire extinguishers shall be provided by the permittee and present while the pyrotechnics are being handled, used, or removed.

- Fire detection and life safety systems shall not be permitted to be interrupted during the operation of pyrotechnic effects.
 - Exception No.1: Portions of fire detection and life safety systems shall be permitted to be interrupted during the operation of temporarily installed pyrotechnic effects when the following conditions are met: (a) Approval of the authority having jurisdiction is received. (b) Approval of the owner or owner's agent is received. (c) An approved fire watch capable of directing the operation of all fire detection and life safety systems installed in the building is present.
 - Exception No.2: Fire detection and life safety systems shall be permitted to be interrupted during the operation of permanently installed pyrotechnic effects only for initial acceptance of the system. (*NFPA 1126.6.1.6*)
- Pyrotechnic devices and materials used indoors shall be specifically manufactured and marked for indoor use by the manufacturer.
- Airbursts shall comply with NFPA 1126 and be subject to the following conditions:
 - The airburst shall be suspended by a minimum 30-gauge metal wire that is attached securely to a secure support acceptable to the authority having jurisdiction.
 - The airburst shall occur at a minimum height of three times the diameter of the effect.
 - Where the effect is demonstrated, there shall be no burning or glowing particles below the 15-ft (4.6 m) level above the floor.
- During pyrotechnic activity the following items must be properly maintained:
 - Access:
 - Fire lane kept clear
 - Hydrants not blocked
 - Fire department connections clear
 - Standpipe connections clear
 - At least two fire extinguishers provided
 - Extinguishing equipment charged and in good working order
 - Warning signs
 - Exits:
 - All designated exits clear
 - Exits visible
 - Pyrotechnic Materials and Devices
 - Proper and current license in the possession of the pyrotechnic operator
 - Permit on site
 - Fire department briefed on proposed activity
 - Proper ventilation
 - Electrical:
 - Cords and connections in good condition
 - Power supply
 - Pyrotechnic firing mechanism in good working order
 - Flame Proofing:
 - Set and scenic materials treated for flame retardance
 - Burlap or other protective materials used for rigging treated for flame retardance.

SECURITY

CONTRACT SECURITY STANDARDS OF PERFORMANCE

The LVCVA Minimum Security Program establishes standards for the assignment and performance of contract security companies operating on LVCVA property. The minimum standards assure that all events occurring on LVCVA property are conducted in a safe and secure environment. Clients are encouraged to communicate with the LVCVA Customer Safety Department as early as possible before the event to ensure ample time is allotted for the preparation of a comprehensive security plan. Phone: (702) 892-7400.

❖ **STANDARDS OF PERFORMANCE**

These Standards of Performance are distributed to all approved contract security companies that work in LVCVA facilities.

- In a continuing effort to provide our customers with legendary service and decrease thefts, the following standards and policies will apply to all contract security companies working at LVCVA facilities. (Note: Violations of these standards may be documented by LVCVA Customer Safety and such documentation will be available to the client.)
 - It is the policy of LVCVA that no person employed by or otherwise associated with any contracted company, vendor or any other entity working on LVCVA property, shall remove any product, material, or other items from LVCVA buildings, freight yards, or service roads, regardless of how it was obtained without the written permission of the Executive Director of Customer Safety or his designee. This is to include material that is discarded, abandoned or given away. Any person in possession of such described material shall be presumed to be in possession of stolen property, regardless of the material's condition or usefulness, and will be subject to permanent trespass from all LVCVA facilities and subject to arrest. Possession includes the movement of property into any parking lot or vehicle. (Exceptions include a person's verifiable personal property such as items necessary to perform one's job, lunch containers or clothing.)
 - Carts, forklifts and other means of conveyance used in conducting the contractor's business shall not be allowed within any LVCVA parking lot except for such times as the lot is leased as exhibit space. Exceptions require the approval of the Executive Director of Customer Safety or his designee.
- Guards will be positioned on post in the most effective location to achieve the mission of the post.
- Guards will be briefed as to their duties at any particular post.
- Guards will be alert and proactive in their duties at all times.
- Guards will remain on post until relieved or until "walk-off" time.
- All guards will be properly groomed.
- All guards will be neatly dressed in an approved uniform and be readily identifiable to others.
- Civilian coats, jackets or hats will not be worn over the uniform.
- Identification card including Sheriff's card will be displayed on the front of the uniform.
- Headsets, radios, iPods, cell phones and televisions are prohibited on post.
- Reading of books, newspapers or magazines is prohibited on post.
- Guards are limited to one small bag for personal items at their post. (All bags subject to search at any time.)
- No sleeping, smoking, eating or drinking (except water) on post.
- Guards are not permitted to sit while on post when there is activity at the post area with the exception of individual booth assignments.
- One chair with a seat level no lower than 30 inches may be placed at each fixed post to allow for occasional short term seating for the posted guard. Lower chairs are not permitted at any post.
- It will be the responsibility of contract management to inform their employees of this policy and standards. These standards may be freely posted, duplicated and distributed. Ignorance of the policy will not be a viable defense and trespass orders may be permanent.
- The following information is provided to assist the client in preparing a successful *security placement plan* to be reviewed by the Executive Director of Customer Safety:
 - LVCC Only: Lobby doors – The common lobby areas of the Las Vegas Convention Center are generally accessible to the public. The glass doors at the lobby entrances do not usually require the posting of contract security guards.
 - LVCC Only: Concourse doors – the hinged and roll-up doors accessing exhibit halls from the lobby and concourse areas are another point of vulnerability. A minimum of one guard should be placed at each ingress/egress door. It is highly recommended that a rover guard be assigned to monitor all concourse doors to watch for propped doors or unauthorized entries.

- Perimeter doors – The LVCVA facilities include hundreds of perimeter doors. These are necessary to allow for rapid evacuations in the case of an emergency. They can also be a point of vulnerability for security purposes. Some event plans allow for perimeter doors to be attendee ingress/egress points. All security placement plans should include coverage for perimeter doors during event activity hours when the exhibit hall is occupied. A minimum of one guard will be posted at designated event ingress and egress points.
- Designated trash doors – Each exhibit hall has a designated trash door. The doors are clearly marked with signage and a flashing blue strobe light above the door. Contract cleaners are restricted to entering and exiting these doors in order to control the movement of trash containers that can be used to transport stolen property.
- LVCC Only: Designated trash door locations:
 - Central Halls – Walk-through doors at freight doors 3 and 6.
 - North Halls – Walk-through doors at freight doors 15 and 24.
 - South Halls – Walk-through doors at 26, 40, and 43
- LVCC Only: LVCVA Customer Safety will not unlock a trash door unless a contract security guard is posted. For a greater level of security two guards are recommended with one positioned inside, the other outside to verify the direct transport of containers to the nearest compactor/dumpster.
- LVCVA Security will immediately lock any trash door that is found with no guard posted.
- All trash containers subject to search. Contract security guards posted at trash doors should be directed to conduct visual checks of carts (whales) to look for possible stolen property.
- Freight doors
- Security must be posted for any/all opened freight doors, including one guard per each opened freight door.
- Contract security will remain posted until move-out is completed.
- Freight doors will not be opened unless contract security is posted.
- Freight doors will be closed if found to be without posted contract security.
- Early move-in/move-out activity is subject to compliance with the Security Companies section of this Building Users Manual.
- Move-in/Move-out: Contract Security must be posted for any/all perimeter opened doors, including one guard per each opened freight door commencing on the day and time early move-in begins.
- Off-Hours: Guards are required to be posted at perimeter and concourse doors that are designated as entry points after show hours and overnight.
- Photo ID's: The LVCVA Building Users Manual mandates the following:
 - All official trade associates and/or member affiliates, including but not limited to building employees, union workers, or contractors needing access to exhibit halls will be required at all times to display photo identification.
 - This badging requirement does not apply to show staff, attendees, or exhibitors who will continue to receive badges directly from the show/lessee.
 - Contract security guards are expected to screen persons entering controlled areas for the required photo ID's. LVCVA Customer Safety will support contract security guards in this enforcement as needed.
- Meeting rooms – The assignment of guards at utilized meeting rooms is at the discretion of the client.
- Breaker ratio – A minimum of one supervisor or person designated as the group leader is required for every six guards on duty. This ensures that guards will get needed rest breaks.
- Booth guards – Booth guards must be hired from a state licensed, EAC approved/permitted company. Exhibitor staff or other unlicensed persons cannot perform security functions. Approved booth guards must carry written authorization from their employer confirming assignment to the booth to include date and times of assignment.

Contracted Security Guard Placement Plan (Cashman Center)

The following is the minimum guard placement standard for Cashman Center, realizing all events are unique, additional guards may be required as directed by LVCVA management.

Exhibit Hall A

A minimum of five (5) security guards consisting of four guards and one supervisor/group leader is required. The guards/placements will be as follows:

- One guard - Exhibit hall main entry doors
- One guard - Freight door or crash doors
- One guard - Roll-up #3 trash doors
- One guard – Corridor Access Point
- One supervisor/group leader
- One guard - overnight/fire watch (if required)
(Overnight guard to be provided relief by a roving supervisor)

Exhibit Hall B

A minimum of five (5) security guards consisting of four guards and one supervisor/group leader is required. The guards/placements will be as follows:

- One guard - Exhibit hall main entry doors
- One guard - Freight door or crash doors
- One guard - Hall B roll-up trash doors
- One guard – 24-hour door
- One supervisor/group leader
- One guard - overnight/fire watch (if required)
(Overnight guard to be provided relief by a roving supervisor)

Meeting Rooms

A minimum of two (2) security guards will be assigned to this area.

- One guard - Main entry doors - Front
- One guard - Entry doors - Rear
- One guard - overnight/fire watch (if required).
(Overnight guard to be provided relief by a roving supervisor)

Theater

A minimum of four (4) security guards consisting of three guards and one supervisor/group leader is required. The guards/placements will be as follows:

- One guard - Main entry doors
- One guard - Rear theater door (female guard may be preferred according to event)
- One guard - Mezzanine level
- One supervisor/group leader
- One guard - overnight/fire watch (if required)
(Overnight guard to be provided relief by a roving supervisor)

Stadium

The following is the minimum guard placement standard for Cashman Center Stadium, realizing all events are unique, additional guards may be required as directed by LVCVA Customer Safety.

Stadium Events (baseball, soccer, football, etc.)

A minimum number of guards/supervisor(s) will be determined by LVCVA Customer Safety based on the specifics of the event. The following lists the general requirements for guard placement:

- One guard on the east wing gate/stairs (1st base side of stadium)
- One guard on the north wing gate/stairs (3rd base side of stadium)
- One guard on the east berm area (when in use)
- One guard on the north berm area (when in use)
- One guard 1st base dugout or field area
- One guard 3rd base dugout or field area
- One guard at Press Gate
- One guard at the Main Gate
- One guard roving on the Concourse Level
- One guard Club Level east wing/stairs (1st base side of stadium)
- One guard Club Level north wing/stairs (3rd base side of stadium)
- One guard at the Party Zone area (when in use)
- One guard at the Visitor's Locker Room in tunnel
- One guard at the Home Locker Room in tunnel
- One guard at the north end of the tunnel
- One guard (minimum) for relief/breaks
- One supervisor/group leader (minimum)

Firework nights will require (6) additional guards plus a second supervisor/relief. The guard placement will be as follows:

- One guard at the gift shop
- One guard on the left field berm
- One guard on the right field berm
- Two guards in Lot D (along Washington Ave.)
- One guard in Lot D (south barricade line)
- One Supervisor/group leader

Parking Lots

Outdoor security staffing will be handled on a per event basis according to leased space and activities scheduled. Designated trailer/equipment storage areas require a minimum of one security guard to be assigned to this area. (Overnight guards to be provided relief by a roving supervisor)

Theater and Exhibit Hall A or B – Same event

When utilizing the theater in conjunction with an exhibit hall for the same event, a minimum of nine (9) security guards consisting of eight guards and one supervisor/group leader is required.

Exhibit Hall

- One supervisor/group leader
- One guard – Hall A or Hall B trash doors (assignment of trash door will be designated by the Cashman Center security supervisor)
- One guard – Exhibit hall corridor/24-hour door
- One guard – Roll-up #3 or Hall B roll-up door
- One guard – Hall B entry doors
- One guard – Hall A/B crash doors or Relief Guard
(Adjustments can be made as event activities vary.)

Theater

- One guard - Main entry doors
- One guard - Rear theater door (female guard may be preferred according to event)
- One guard - Mezzanine level
- One guard - overnight/fire watch (if required)
(Overnight guard to be provided relief by a roving supervisor)

Exhibit Halls A and B – Same Event

When utilizing both exhibit halls for the same event, a minimum of eight (8) security guards consisting of seven guards and one supervisor/group leader is required. The guards/placements will be as follows:

- One guard - Hall A entry/exit doors
- One guard - Hall B entry/exit doors
- One guard - Hall A and B crash doors (roving)
- One guard - Hall A or B trash door (assignment of trash door will be designated by Cashman Center security supervisor)
- One guard - Exhibit Hall corridor (north end)
- One guard – 24-hour entry door
- One supervisor/group leader
(Overnight guards to be provided relief by a roving supervisor)

Meeting Rooms and Exhibit Halls – Same Event

When utilizing meeting rooms in conjunction with both exhibit halls for the same event, a minimum of nine (9) security guards consisting of 8 guards and one supervisor/group leader is required. The guards/placements will be as follows:

Meeting Rooms

- One guard – Meeting room front entry doors
- One guard – Meeting room rear entry doors
- One guard – Hall A entry door or roll-up door #2

Exhibit Halls

- One guard - Hall A entry/exit doors
- One guard - Hall B entry/exit doors
- One guard - Hall A and B crash doors (roving)
- One guard - Hall A or B trash door (assignment of trash door will be designated by Cashman Center security supervisor)
- One guard - Exhibit Hall corridor or 24-hour entry door
- One supervisor/group leader
(Overnight guards to be provided relief by a roving supervisor)

SECURITY COMPANIES (PRIVATE)

Private security companies must be licensed by the State of Nevada Private Investigators Licensing Board to conduct business as a private patrolman per Chapter 248 N.R.S.

RULES AND REGULATIONS

- The following requirements must be met in order for a private security company to work in LVCC/Cashman Center.
 - The Las Vegas Convention and Visitors Authority require a \$250 annual fee from all independent Official Service Contractors providing a service at the Las Vegas Convention Center and Cashman Center. [See Contractors and Vendor Requirements.](#)
 - Copy of current city/county business license on file with the LVCVA Customer Safety Department per local ordinance.
 - Copy of current certificate of insurance showing valid Nevada worker's compensation coverage.
 - A certificate of insurance for \$1 million naming the Las Vegas Convention and Visitors Authority as additional insured. (General Liability in the amount of one million dollars (\$1,000,000) combined single limit bodily injury and broad form property damage coverage, including broad form contractual liability.)
 - During the course of a show (to include move-in and move-out), LVCVA Customer Safety will be furnished a copy of all criminal, incident or injury reports which occur on this property. These are to be delivered to LVCVA Customer Safety during the shift in which the incident occurred or as soon as possible thereafter. Notify LVCVA Customer Safety immediately of any major offense or unusual activity which may require reporting, assistance or follow-up investigation.
 - Report all lost and found to the LVCVA Customer Safety.
 - Contract security agencies will keep LVCVA Customer Safety informed of any action taken against any person(s) or of any properties seized, recovered or found.
 - LVCC/Cashman Center door numbers will be used by contract security agencies for requests of assistance or for opening and closing areas (as requested by show management). All freight doors and pedestrian doors are clearly marked. In addition, the hall in which the doors are located will be identified.
 - Any deviations from these policies must have prior written approval from the LVCVA Executive Director of Customer Safety.
- Security guards must have their Sheriff's work card prominently displayed on their uniform and any other documents that may be required by city/county ordinance or state law. They must be in a distinctive uniform approved by the State of Nevada Private Investigator's Licensing Board, the Metropolitan Police Department and the LVCVA.

WEAPONS

- Weapons of any type are not allowed on property.
- Possession of a firearm on LVCVA property may be approved as follows:
 - A letter to your Convention Services Manager from the organization/convention on their letterhead that is contracting your services requesting armed officers and the reason for the request. The [LVCVA Weapons Request Form](#) filled out in full with all information attached, including signature of the Show Manager
 - Armed security guards must be in uniform and wear a distinctive badge.
 - All security guards must display a Clark County Sheriff's card.

ALL INFORMATION IN THIS MANUAL IS SUBJECT TO CHANGE

FORMS



Food and Beverage Sampling / On-Site Preparation Approval Form

To provide a safe and comfortable tradeshow environment, and to comply with fire safety codes, the Catering Department at the LVCC requires specific information for all on-site food and beverage preparation and dispensing.

Name of Event: _____ Date of Event: _____

Company Name: _____ Booth #: _____

Contact/Title: _____ Contact Number: _____

Email: _____ On-Site Contact Number: _____

Proprietary Product to be Prepared/Sampled: _____

Non-Alcoholic Beverages are limited to a maximum 3oz containers. All alcoholic beverage sampling requires prior approval as specific laws and policies apply. Please speak with your catering sales manager for further information.

Food items are limited to a sample size not more than 2oz.

Portion Size to be Dispensed 2oz 3oz

Nevada Health Law requires use of a hand washing and sanitation station when sampling or preparing food/beverage.

You may provide your own station or purchase from Centerplate.

Will you be purchasing a hand washing and sanitation kit from Centerplate? Yes No

If yes, a member of the Catering Department at the LVCC will be in contact.

Will you be heating or cooking food? Yes No

If yes, an LVCVA Fire Prevention coordinator will be in contact

Please list the heating or cooking equipment to be used: _____

By submitting this form, I acknowledge I have read and understand the food and beverage policies at the LVCC.

Approval from both LVCC and the Catering Department at LVCC must be received prior to finalizing your plans. Email completed form to: foodprepandsample@lvcva.com

All aforementioned policies will be strictly managed by the LVCC, Centerplate, and the Southern Nevada Health District. Any violation will result in the removal of product from the show floor and or obligatory discontinuation of booth activities.



EXHIBITOR APPOINTED CONTRACTOR & VENDOR REQUIREMENTS

Any show-appointed and/or exhibitor-appointed company providing a service in a supervisor or non-supervisory role during conventions, trade shows and events on the property of the Las Vegas Convention Center or Cashman Center must comply with the following requirements prior to commencement of work at either facility. Permits are issued on an annual basis.

1. ANNUAL CONTRACTOR FEE \$250.00

2. CERTIFICATE OF INSURANCE

- General Liability in the amount of one million dollars (\$1,000,000) combined single limit bodily injury and broad form property damage coverage, including broad form contractual liability, **naming the Las Vegas Convention and Visitors Authority as additional insured.** Contractor shall annually provide the LVCVA with a certificate evidencing such insurance. **The “Insured” listed on the Certificate of Insurance must exactly match the “Name of Company” set forth on page 2.**
- Workers’ Compensation Coverage in the State of Nevada with minimum of one million dollars (\$1,000,000) limit. **If the home state of the contractor does not have a reciprocal agreement with the State of Nevada, contact Employers Insurance Company of Nevada (EICN) to obtain proper coverage. Phone (702) 837-3000 or www.eicn.com**

3. ESCA BADGE REQUIREMENT

- **All company employees MUST have *WIS/ESCA ID Badges** in order to work at either facility.

4. LEGAL COMPLIANCE

- For an in consideration of the Permit, each contractor agrees to indemnify, defend and hold the LVCVA harmless for damages, claims or expenses incurred by the LVCVA that are attributable to the contractor or its actions or inactions at the LVCC and/or Cashman Center. Such damages, claims or expenses include, but are not limited to, those related to (1) the handling of hazardous materials; (2) negligence or intentional conduct; (3) violation of any law or regulation; and (4) additional security resulting from labor strikes and the like. Where appropriate, expenses will be charged to the responsible contractor on a pro rata basis.

Please select which category of business your company performs (select all that apply)

- | | | |
|---|--|--|
| <input type="checkbox"/> Audio Visual/Lighting | <input type="checkbox"/> Fire Protection | <input type="checkbox"/> Production |
| <input type="checkbox"/> Cleaning | <input type="checkbox"/> Floral/Plants | <input type="checkbox"/> Supervisory |
| <input type="checkbox"/> Computer Rentals | <input type="checkbox"/> Flooring | <input type="checkbox"/> Security/Private Investigator |
| <input type="checkbox"/> Destination/Event Management | <input type="checkbox"/> General Contractor | <input type="checkbox"/> Temporary Staffing |
| <input type="checkbox"/> Display/Design | <input type="checkbox"/> Install/Dismantle (I & D) | <input type="checkbox"/> Tents/Pavilions/Temp Structures |
| <input type="checkbox"/> Entertainment/Talent/Modeling | <input type="checkbox"/> Labor | <input type="checkbox"/> Theatrical/Rigging |
| <input type="checkbox"/> Equipment/Furniture Rental | <input type="checkbox"/> Medical | <input type="checkbox"/> Transportation |
| <input type="checkbox"/> Exhibit House/Tradeshow Exhibits | <input type="checkbox"/> Photography/Videography/Recording | <input type="checkbox"/> Misc./Other* |

*Misc./Other selected, please list the category(s) here: _____

I agree to provide all required payments and evidence of compliance with requirements set forth herein. Further, I agree to the terms and conditions set forth in Section 4 hereof.

Name of Company: _____

DBA (if applicable): _____

Address: _____

City, State, Zip: _____

EAC Contact: _____
(Print Name)

Title: _____ Date: _____

Web Address: _____ Phone: _____

E-Mail Address: _____ Fax: _____

Payment Method: Check attached **OR** To pay with a credit card via Square*, please provide email address of CC holder: _____

**An invoice will be emailed via Square to complete credit card information.*

- **By submitting this form with payment option selected above, payee acknowledges application is valid and enforceable**
- I understand the *WIS/ESCA badge requirement
- Include certificate of insurance for general liability and worker's compensation as described in section 2
- Make check payable to the Las Vegas Convention and Visitors Authority
- Return this form with a check for \$250 for the annual fee to the following address:

Sr. Director of Convention Services
Las Vegas Convention and Visitors Authority
3150 Paradise Road
Las Vegas, NV 89109

Direct questions to the Convention Services Department, LVCVA
Phone: (702) 892-2860 Email: eacpermit@lvca.com

- Completed Form
- \$250.00 Contractor Fee
- Certificate of Insurance with appropriate coverage
- I understand the *WIS/ESCA badge requirement

All documents must be received BEFORE work may commence on the property of the Las Vegas Convention Center or Cashman Center

ALL CONTRACTORS MUST OBTAIN A BUSINESS LICENSE WHEN WORKING AT EITHER THE LAS VEGAS CONVENTION CENTER OR CASHMAN CENTER. Please click <http://www.clarkcountynv.gov/business-license/Pages/BusinessLicenseServiceSpotlight.aspx> or contact the following entities below for further information:

Clark County Department of Business License
500 Grand Central Parkway, Third Floor
Las Vegas, NV 89155
702-455-0174
www.clarkcountynv.gov

Business Licensing Division Planning Department
333 North Rancho Drive
Las Vegas, NV 89106
702-229-6281
www.lasvegasnevada.gov



HELICOPTER LANDING REQUEST FORM

Name of Show: _____

Name of Exhibiting Company _____

Exhibit Hall: _____ Booth Number: _____

Contact Person/Title: _____

Phone: _____ Email: _____

Proposed landing date, if known: _____

Proposed landing location, if known: _____

Type of helicopter: _____

This is an initial form of contact only. Once received, the Las Vegas Convention and Visitor's Authority will contact you and advise you of insurance requirements. You will then work with the LVCVA to finalize the details.

Please complete this form and email it to conventionservices@lvcva.com for approval.
Helicopters will not be permitted to land without prior authorization.

This area for LVCVA use, please do not write below

Final landing date: _____ Time: _____ Location: _____

Contractor Contact: _____ Cell #: _____

On-site exhibitor contact: _____ Cell #: _____

Take-off date: _____ Time: _____ Location: _____

For info phone: (702) 892-0711
LVCVA reserves the right to update or change this policy without written notice

SAMPLE INSURANCE CERTIFICATE

CERTIFICATE OF LIABILITY INSURANCE

DATE(MM/DD/YYYY)

THIS CERTIFICATE IS ISSUED AS A MATTER OF INFORMATION ONLY AND CONFERS NO RIGHTS UPON THE CERTIFICATE HOLDER. THIS CERTIFICATE DOES NOT AFFIRMATIVELY OR NEGATIVELY AMEND, EXTEND OR ALTER THE COVERAGE AFFORDED BY THE POLICIES BELOW. THIS CERTIFICATE OF INSURANCE DOES NOT CONSTITUTE A CONTRACT BETWEEN THE ISSUING INSURER(S), AUTHORIZED REPRESENTATIVE OR PRODUCER, AND THE CERTIFICATE HOLDER.

IMPORTANT: If the certificate holder is an ADDITIONAL INSURED, the policy(ies) must be endorsed. If SUBROGATION IS WAIVED, subject to the terms and conditions of the policy, certain policies may require an endorsement. A statement on this certificate does not confer rights to the certificate holder in lieu of such endorsement(s).

PRODUCER INSURANCE BROKER/AGENT	CONTACT NAME: _____ PHONE (A/C, No, Ext): _____ FAX (A/C, No): _____ E-MAIL: _____ ADDRESS: _____ INSURER(S) AFFORDING COVERAGE INSURER A : Carrier A Must have an AM Best Rating of A-VII or Better INSURER B : Carrier A Must have an AM Best Rating of A-VII or Better INSURER C : _____ INSURER D : _____ INSURER E : _____ INSURER F : _____
INSURED COMPANY NAME (must match lease holder) ADDRESS CITY, STATE, ZIP	NAIC # _____

COVERAGES CERTIFICATE NUMBER: REVISION NUMBER:

THIS IS TO CERTIFY THAT THE POLICIES OF INSURANCE LISTED BELOW HAVE BEEN ISSUED TO THE INSURED NAMED ABOVE FOR THE POLICY PERIOD INDICATED. NOTWITHSTANDING ANY REQUIREMENT, TERM OR CONDITION OF ANY CONTRACT OR OTHER DOCUMENT WITH RESPECT TO WHICH THIS CERTIFICATE MAY BE ISSUED OR MAY PERTAIN, THE INSURANCE AFFORDED BY THE POLICIES DESCRIBED HEREIN IS SUBJECT TO ALL THE TERMS, EXCLUSIONS AND CONDITIONS OF SUCH POLICIES. LIMITS SHOWN MAY HAVE BEEN REDUCED BY PAID CLAIMS.

INSR LTR	TYPE OF INSURANCE	ADDL INSR	SUBR WVD	POLICY NUMBER	POLICY EFF (MM/DD/YYYY)	POLICY EXP (MM/DD/YYYY)	LIMITS	
A	GENERAL LIABILITY <input checked="" type="checkbox"/> COMMERCIAL GENERAL LIABILITY <input type="checkbox"/> CLAIMS-MADE <input checked="" type="checkbox"/> OCCUR GENL AGGREGATE LIMIT APPLIES PER: <input type="checkbox"/> POLICY <input type="checkbox"/> PROJECT <input type="checkbox"/> LOC		X				EACH OCCURRENCE \$ 1,000,000 DAMAGE TO RENTED PREMISES (Each occurrence) \$ _____ MED EXP (Any one person) \$ _____ PERSONAL & ADV INJURY \$ 1,000,000 GENERAL AGGREGATE \$ 1,000,000 PRODUCTS - COMP/OP AGG \$ 1,000,000 _____ \$ _____	
	AUTOMOBILE LIABILITY <input checked="" type="checkbox"/> ANY AUTO ALL OWNED AUTOS <input type="checkbox"/> SCHEDULED AUTOS HIRED AUTOS <input checked="" type="checkbox"/> NON-OWNED AUTOS		X					COMBINED SINGLE LIMIT (Each accident) \$ 1,000,000 BODILY INJURY (Perperson) \$ _____ BODILY INJURY (Peraccident) \$ _____ PROPERTY DAMAGE (PER ACCIDENT) \$ _____ _____ \$ _____
	UMBRELLA LIAB <input type="checkbox"/> OCCUR EXCESS LIAB <input type="checkbox"/> CLAIMS-MADE DED \$ _____ RETENTION \$ _____							EACH OCCURRENCE \$ _____ AGGREGATE \$ _____ _____ \$ _____
B	WORKERS COMPENSATION AND EMPLOYERS' LIABILITY ANY PROPRIETOR/PARTNER/EXECUTIVE OFFICER/MEMBER EXCLUDED? (Mandatory in NH) If yes, describe under DESCRIPTION OF OPERATIONS below			N/A			<input checked="" type="checkbox"/> WC STATUTORY LIMITS <input type="checkbox"/> OTHER E.L. EACH ACCIDENT \$ 1,000,000 E.L. DISEASE - EA EMPLOYEE \$ 1,000,000 E.L. DISEASE - POLICY LIMIT \$ 1,000,000	

DESCRIPTION OF OPERATIONS / LOCATIONS / VEHICLES:
 Each liability policy shall be endorsed to include the Las Vegas Convention and Visitors Authority, its officers, employees, and volunteers as additional insureds. These policies shall be primary and any other insurance carried shall be excess and non-contributing. (All deductibles and self-insured retentions shall be fully disclosed.)

CERTIFICATE HOLDER LAS VEGAS CONVENTION AND VISITORS AUTHORITY 3150 PARADISE ROAD LAS VEGAS, NV 89109	CANCELLATION SHOULD ANY OF THE ABOVE DESCRIBED POLICIES BE CANCELLED BEFORE THE EXPIRATION DATE THEREOF, NOTICE WILL BE DELIVERED IN ACCORDANCE WITH THE POLICY PROVISIONS. AUTHORIZED REPRESENTATIVE Must be signed by person authorized by insurer and licensed by the State of Nevada
---	---



Roof Access for Equipment Installation

Name of Show: _____ Exhibiting Company: _____

Contact: _____ Booth #: _____ Exhibit hall: _____

Exhibitor EAC EAC company: _____

Mobile phone: _____ Email: _____

Install Date: _____ Install Time: _____

Removal Date: _____ Removal Time: _____

Description of equipment to be installed:

All equipment placed on the roof must be labeled with the contractor's name, booth number, and show name.

Will you require cabling? Yes No

Cox Business is the exclusive provider of transport services for the LV Convention Center. They can extend or provide cabling from the roof pad to your booth or exhibit area. Please contact them directly for pricing: Lvcc.orders@cox.com or (855) 519-2624

Cox order #: _____

Please complete this form and email it to conventionservices@lvva.com for approval.

RULES AND REGULATIONS

- All persons desiring roof access must first obtain authorization and a special roof access pass.
- Persons accessing the roof without a pass will be trespassed.
- Access to the roof areas via lift is prohibited.
- Fall protection is required for all persons accessing the roof:
 - When on a sloped roof;
 - When within 10 feet of the edge of a flat roof;
 - When within 10 feet of an unprotected skylight; or
 - When otherwise required by OSHA 1926 Subpart M.
- Foot traffic over roof surfaces must be via mats where provided.
- Penetration of the roof surface is prohibited.
- Any items, such as wiring, satellite dishes, etc., placed on the roof for a show, must be placed on designated platforms. Equipment must be removed during move-out of show.
- Individuals blocking or taping open any roof access doors will be trespassed from property.

Roof access times are 7:30 am – 4:30 pm, unless special arrangements are made in advance. Hours may vary due to weather conditions and day light savings time. Once written approval has been given, you will go to the Engineering Department on the specified installation date to complete the process.

**LAS VEGAS CONVENTION AND VISITORS AUTHORITY
CUSTOMER SAFETY DEPARTMENT**

WEAPONS REQUEST FORM
3150 PARADISE ROAD
LAS VEGAS, NV 89109-9096
(702) 892-7400 FAX: (702) 892-7410

DATE: _____

TO: LAS VEGAS CONVENTION AND VISITORS AUTHORITY, EXECUTIVE DIRECTOR OF CUSTOMER SAFETY

FROM: _____
Company Name

SUBJECT: WEAPONS REQUEST

We are requesting Security Officer _____ be permitted
(Please Print Name)

to wear the below listed firearm at:

Las Vegas Convention Center Cashman Center

For the following convention or event: _____
(Please Print)

the above named officer will be located at _____

for the following reasons: _____

FROM:

DATE _____ TIME _____ TO _____

DATE _____ TIME _____ TO _____

DATE _____ TIME _____ TO _____

Please check one: In Uniform In Civilian Clothes *(If concealed, CCW permit is required)*

The following must be submitted with this request:

State of Nevada ~ Private Investigators Licensing Board (PILB) # _____

Expiration Date _____

State of Nevada Firearm Safety Course # _____ Expiration Date _____

Firearm Serial # _____ Manufacturer _____

Caliber _____ Type _____ Color _____

Copy of the PLIB identification card and proof of completing a Firearm Safety Course are attached. Submission of this form must also include proof of insurance, which reflects that the security company, who is providing armed security, has a current insurance liability policy covering armed personnel. This is in addition to show management's approval.

THIS REQUEST MUST BE SUBMITTED TO THE LVCVA SECURITY DEPARTMENT 72 HOURS PRIOR TO THE DATE REQUESTED TO BE ON LVCVA PROPERTY.

COMPANY REPRESENTATIVE: _____ PRINT NAME / TITLE & SIGNATURE _____

SHOW MANAGER APPROVAL _____

_____ Approved _____ Disapproved _____

LVCVA Executive Director of Customer Safety



REMOTELY PILOTED AIRCRAFT SYSTEMS (RPAS)/ UAV/ DRONES

Name of Event: _____ Date of Event: _____

Booth #: _____ Meeting Room #: _____

Name of Exhibiting Company _____

Contact Person/Title: _____

Phone: _____ Email: _____

Power Source: Battery or Other: _____

- Weighs less than 55 lbs.
- Will be flown in a fully enclosed area (including ceiling) using netting, plastic, or other safety measure. Tethering is not an approved safety measure. Netting must be made of material that is sturdy enough to prevent the RPAS from breaking or escaping the enclosure.
- The demonstration will stay restricted to the booth space.
- Will maintain a distance of 18 inches away from any building structure including sprinklers.

RPAS/UAV/Drone Guidelines

- Exhibitors must have approval from show management and your Convention Services Manager (CSM) before flying any RPAS.
- This form must be completed and submitted.
- RPAS carrying weapons are prohibited.
- RPAS may not be flown in lobbies, restaurants or other common areas.
- RPAS are prohibited from flying over populated areas.

Outdoors

- FAA regulations restrict RPAS from being flown outdoors within five (5) nautical miles in class Bravo airspace (McCarran International Airport) and class Delta airspace (North Las Vegas Airport). Due to the proximity to these airports, RPAS are prohibited from flying outside on any LVCVA campus. Waivers can be obtained through the FAA but must be provided to the Convention Services Manager in advance of the event.

I have read the RPAS/UAV/Drone guidelines



APPLICATION FOR COMBUSTIBLE OR EXPLOSIVE PRODUCTS TO BE SOLD, DISPLAYED, OR KEPT WITHIN EXHIBITS

This application is to ensure that those products listed below shall be fully compliant with all applicable Federal, State, local and facility statutes, codes and ordinances, rules and regulations, for the handling, exhibition and storage of combust and explosive materials.

Dates of Event: _____ Booth / Table Number: _____

Name of Exhibiting Company: _____

Contact Person/Title: _____

Phone: _____ Fax: _____

Email: _____

Exhibitor Signature: _____

Indicate all combustibles and explosives that will be present within the booth during the gun show event:
(Please print or type legibly. Unreadable applications cannot be processed and approved.)

Product	Amount	Separation	Approved	Denied	Pending
Binary Explosives <i>(Limit: 5 lbs., per ingredient; ≥ 10 lbs. total)</i>		≥ 10 ft.			
Black Powder <i>(Limit: 1 lb., per entire exhibit hall)</i>					
Smokeless Powder <i>(Limit: 20 lbs., per entire exhibit hall)</i>					
Primers <i>(limit: 10,000 primers, per entire exhibit hall)</i>		≥ 15 ft.			
Flares <i>(Limit: 1 lb.)</i>					
Magnesium Fines <i>(Limit: 1 lb.)</i>					
Pyrotechnic Propellants <i>(Limit: 1 lb.)</i>					
Magnesium Fire Starters <i>(For Display, Only)</i>					
Hydrocarbon Solids Fire Starters <i>(For Display, Only)</i>					
Thermite <i>(Not allowed in the facility)</i>					

Items that are pending may require additional information from exhibitors. Contact Fire Prevention Office.

NOTE: Open flames are not permitted inside the exhibit hall during gun show events.

Please email, fax or deliver this form to:

Fire Prevention Office
 Las Vegas Convention & Visitors Authority
 3150 Paradise Road
 Las Vegas, Nevada, 89109
 FAX: (702) 892-2919
 24/7: (702) 892-7400
 Email: boothplans@lvcva.com